

ILLUSTRATED PARTS LIST

CONTENTS

		Page
1	Machine Bed	57
2	Fixed Carriage	59
3	Adjustable Carriage	61
4	Column and Head	63
5	Driven Sprocket	67
6	Idle Tension Sprocket	69
7	Plain Chain Link	71
8	Disappearing Dog Chain Link	73
9	Flat Back Finger and Trapping Dogs	75
10	Top Pressure Drive Unit Assembly	77
11	Top Pressure Adjustment - Double Column	81
12	Top Pressure Adjustment - Single Column	83
13	Side Adjustment - Top Pressures	85
14	Rear Pulley - 'V' Belt Top Pressure	87
15	Front Pulley - 'V' Belt Top Pressure	89
16	Pressure Arm - 'V' Belt Top Pressure	91
17	Front Pulley - Caterpillar Top Pressure	93
18	Rear Pulley - Caterpillar Top Pressure	95
19	Caterpillar Pressure Pads	97
20	Standard 1.5m Infeed Fence	99
21	'A' Type Head	101
22	'B' Type Head	103
23	Beam Mounted Scorer Body	107
24	Belt Driven Scorer Head	109
25	Head Mounted Scorer Body	115
26	Relishing Head	115
27	Timing Drum	119

IMPORTANT: WHEN ORDERING SPARES ALWAYS QUOTE MODEL AND MACHINE NUMBER

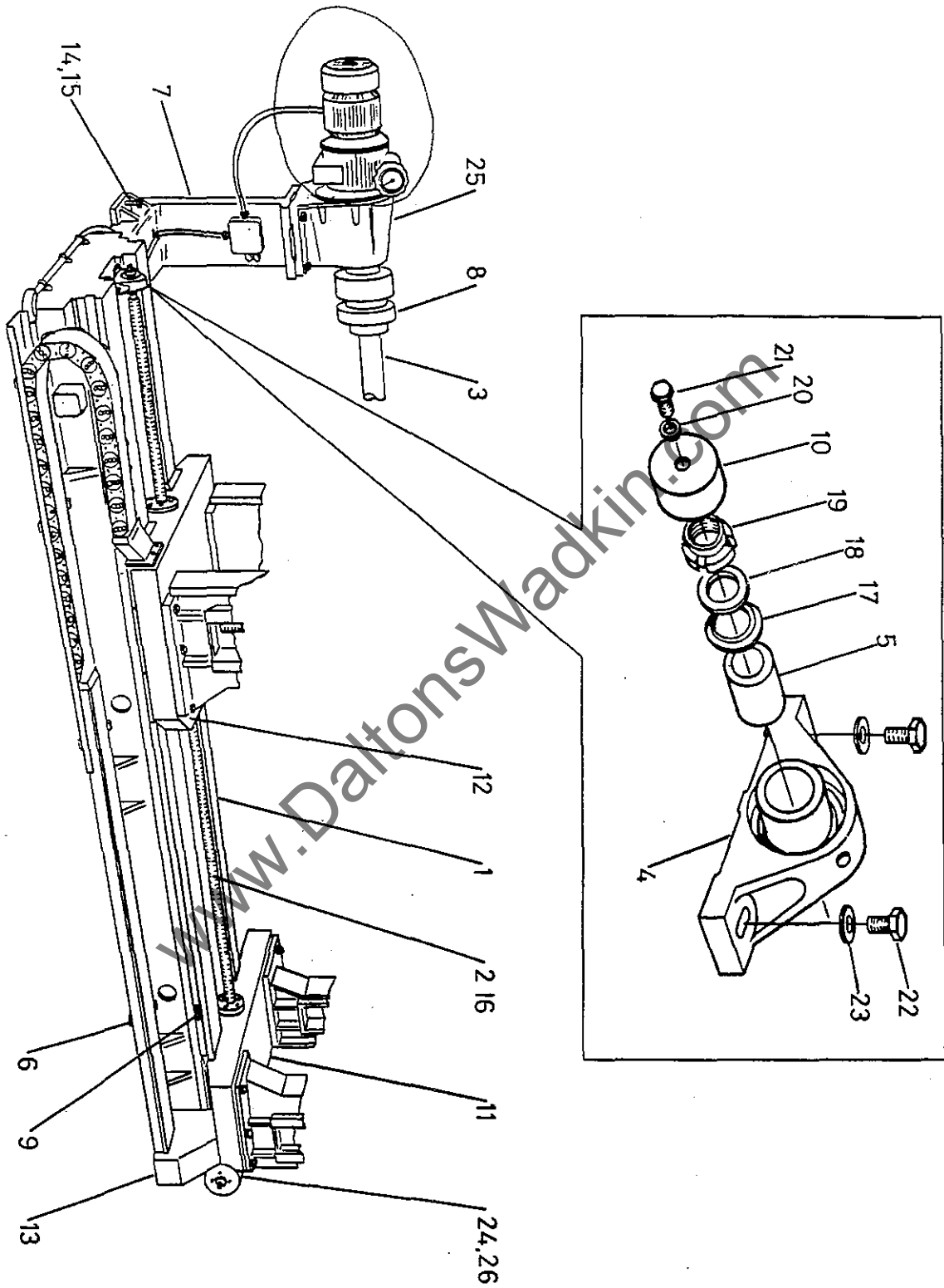

FIG 1 MACHINE BED

1 MACHINE BED

Ref	Description	No. off
1	1.9 Metre Bed	1
	or 3.0 Metre Bed	1
	or 4.1 Metre Bed	1
2	1.9 Metre Traverse Screw	1
	or 3.0 Metre Traverse Screw	1
	or 4.1 Metre Traverse Screw	1
3	1.9 Metre Backshaft	1
	or 3.0 Metre Backshaft	1
	or 4.1 Metre Backshaft	1
4	Pillow Block Bearing 'RHP' NP35	1
5	Bush	1
6	Cable Runway Support	4
7	Feed Drive Plinth	1
8	Torque Limiter	1
9	Cam Plate	2
10	Cover for Traverse Screw	1
11	Fixed Carriage	1
12	Adjustable Carriage	1
13	Cable Connection Box	1
14	Hexagon Head Setscrew M16 x 80mm long	8
15	Lock Nut M16	8
16	Key 8mm x 7mm x 80mm (Traverse Screw Drive)	1
17	Disc Washer 40mm O/D x 20mm I/D x 2.5mm	1
18	Thrust Washer 'INA' WS 81104	1
19	Self Locking Nut M20 x 1.0p	1
20	Plain Washer M6	1
21	Hexagon Head Setscrew M6 x 25mm long	1
22	Hexagon Head Setscrew M12 x 45mm long	2
23	Large Plain Washer M12	2
24	Lenze Gearbox Type 05 / 80 52.114 (rear of bed)	1
25	'Simplatrol' Disco Feed Drive Unit	1
26	Traverse Motor 'Brook' DNV9OLD.1.1/0	1

SECTION 5

ILLUSTRATED PARTS LIST

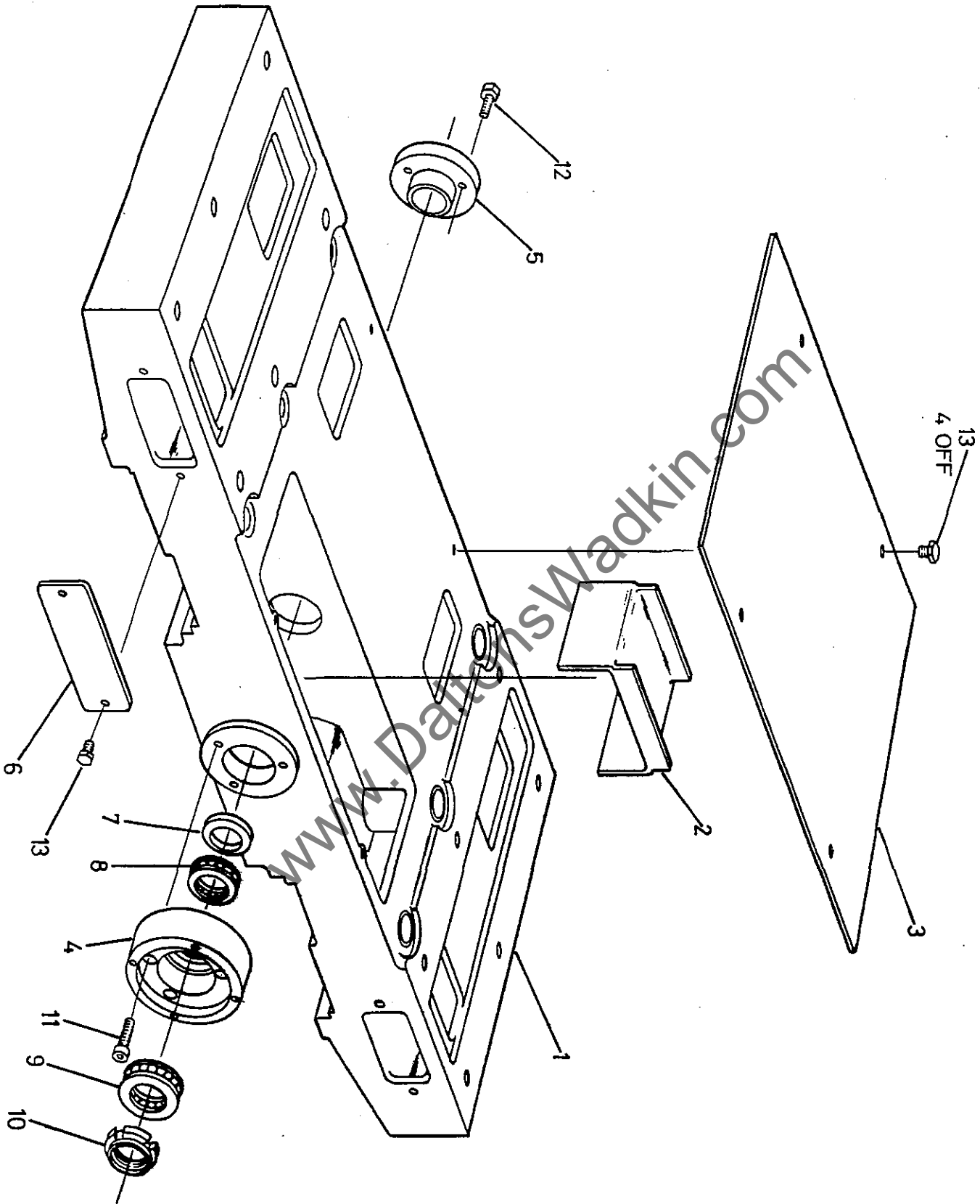

FIG 2 FIXED CARRIAGE

2 FIXED CARRIAGE

Ref	Description	No. Off
1	Fixed Carriage	1
2	Traverse Screw Cover	
3	Cover	1
4	Gearbox Mounting Flange	1
5	Leadscrew Support	1
6	Cover	2
7	Bearing Bracket Ring	1
8	Thrust Bearing SKF 51106	1
9	Thrust Bearing SKF 51206	1
10	Self Locking Nut M30 x 1.5	1
11	Hexagon Socket Capscrew M10 x 30mm long	3
12	Hexagon Head Setscrew M10 x 30mm long	3
13	Hexagon Head Setscrew M6 x 12mm long	8

www.DaltonsWadkin.com

SECTION 5

ILLUSTRATED PARTS LIST

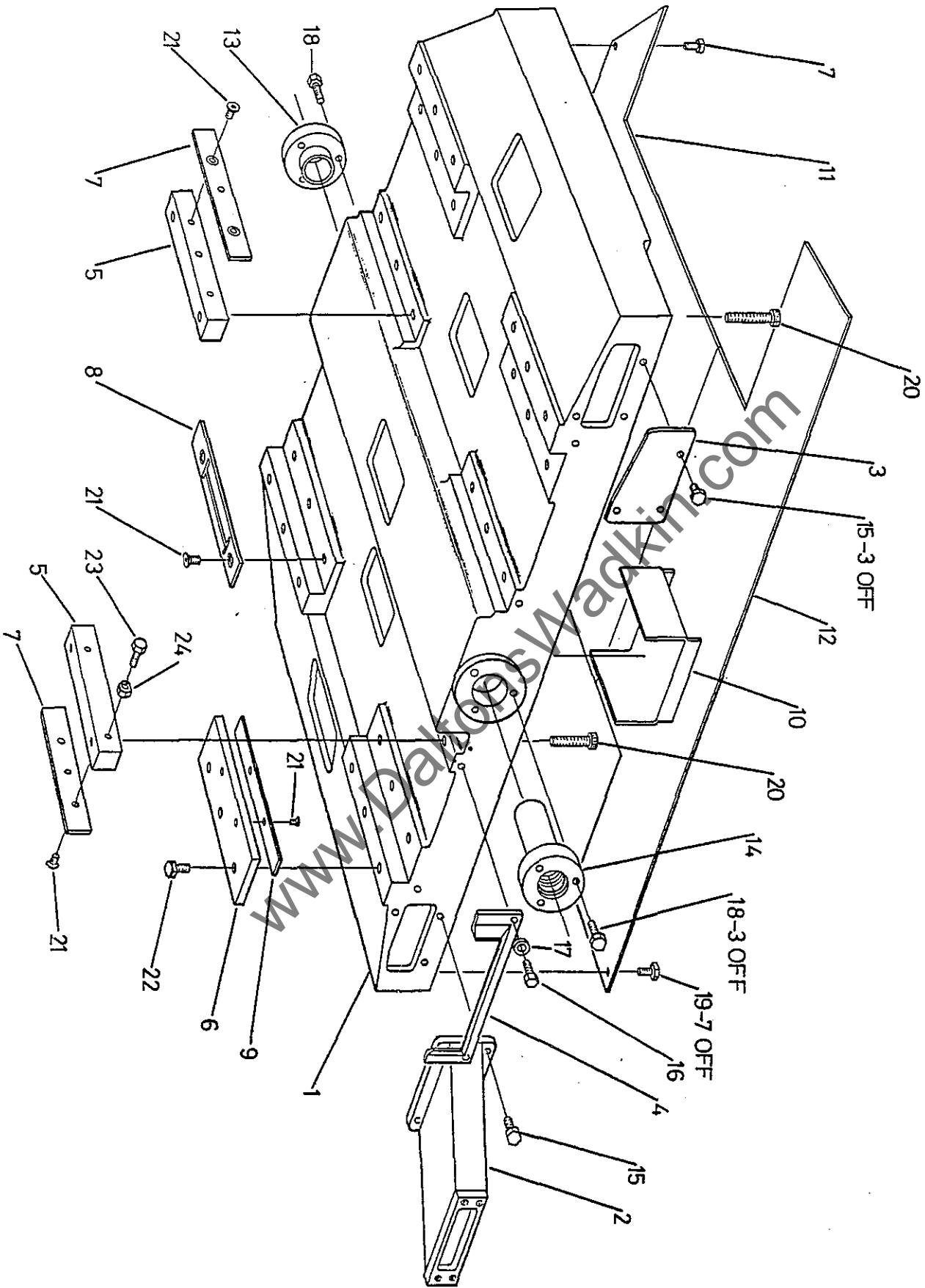

FIG 3 ADJUSTABLE CARRIAGE

3 ADJUSTABLE CARRIAGE

Ref	Description	No. Off
1	Adjustable Carriage	1
2	Cable Runaway Connector	1
3	Cover Plate	1
4	Slideway Wiper	4
5	Side Guide Block	4
6	Keep Plate	4
7	Side Guide Bearing	4
8	Bearing Plate	4
9	Keep Plate Bearing	4
10	Traverse Screw Cover	1
11	Cover	1
12	Cover	1
13	Leadscrew Support	1
14	Traverse Nut WA 337	1
15	Hexagon Head Setscrew M8 x 16mm long	6
16	Hexagon head Setscrew M6 x 16mm long	8
17	Large Plain Washer M6	8
18	Hexagon Head Setscrew M10 x 30mm long	6
19	Hexagon Head Setscrew M6 x 12mm long	14
20	Hexagon Socket Capscrew M10 x 35mm long	8
21	Hexagon Socket Countersunk Capscrew M4 x 8mm long	24
22	Hexagon Head Setscrew M12 x 25mm long	12
23	Hexagon Head Setscrew M10 x 35mm long	4
24	Nut M10	4



ILLUSTRATED PARTS LIST

SECTION 5

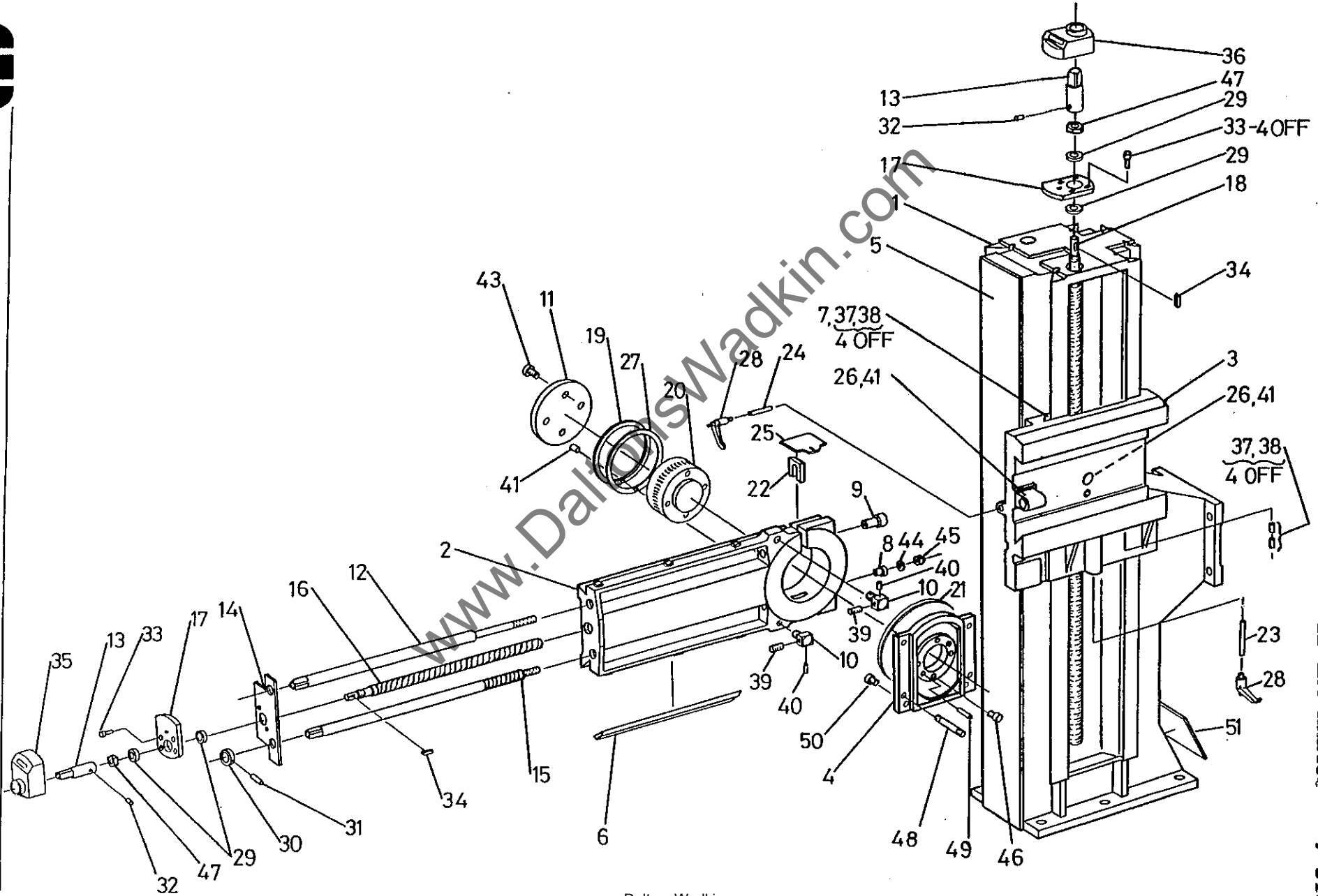

FIG 4 COLUMN AND HEAD

4 COLUMN AND HEAD

Ref	Description	No. Off
1	Column	1
2	Head Slide L.H. (Shown)	1
	or Head Slide R.H.	1
3	Back Slide L.H. (Shown)	1
	or Back Slide R.H.	1
4	Motor Mounting Plate (standard shown)	1
	or Motor Mounting Plate for use with head mounted scorer	1
5	Column Cover	1
6	Horizontal Gib for Head Slide	1
7	Vertical Gib for Head Slide	1
8	Bush	1
9	Locking Screw Nut <i>WDA 151</i>	1
10	Adjustable Stop	2
11	Hub Clamp Plate	1
12	Locking Screw <i>WMA 150</i>	1
13	Adaptor	2
14	Traverse and Lock Scale L.H. (Shown)	1
	traverse and Lock Scale R.H.	1
15	Worm Shaft	1
16	Horizontal Leadscrew	1
17	Thrust Plate	2
18	Vertical Leadscrew	1
19	Hub Thrust Bearing	1
20	Hub/Worm Wheel <i>WMA 152</i>	1
21	Cant Scale	1
22	Rubber Insert	1
23	Clamping Slug	1
24	Clamping slug	1
25	Canting Scale Marker	1
26	Back Slide Nut	2
27	Shims	As required
28	Bristol Handle M10	2
29	Thrust Bearing 'SKF' 51102	4
30	Collar 20mm I/D x 32mm O/D x 14mm	1
31	Tension Pin dia 6mm x 32mm long	1
32	Socket Head Grubscrew M6 x 6mm long	2

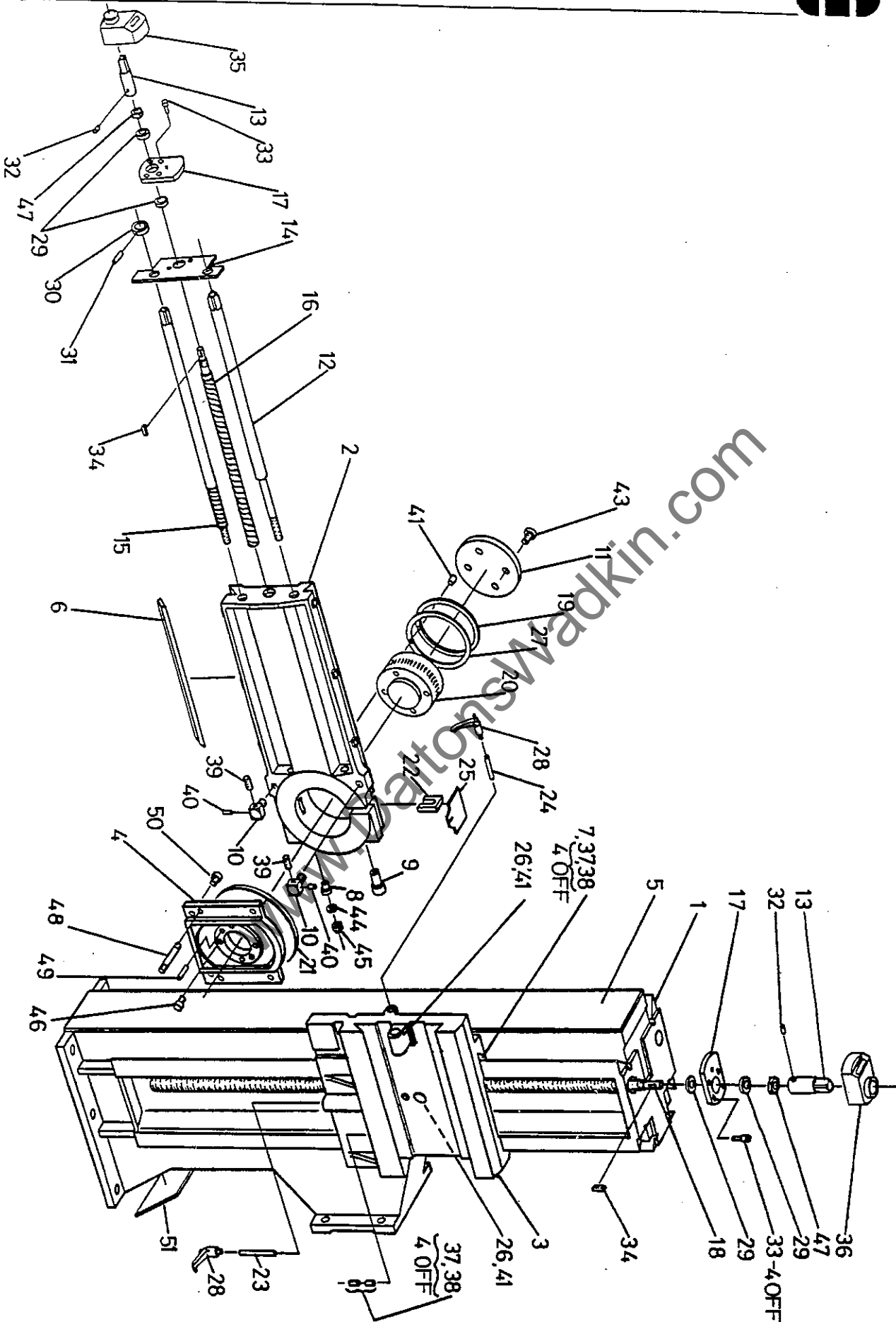

FIG 4 COLUMN AND HEAD

4 COLUMN AND HEAD - CONT.....

Ref	Description	No. Off
33	Hexagon Socket Capscrew M6 x 16mm long	6
34	Key 4mm x 4mm x 20mm	2
35	'SIKO' Dial Indicator 0902E 4mm	1
36	'SIKO' Dial Indicator 09041 4mm (when used as a top head)	1
or	'SIKO' Dial Indicator 0902E 4mm (When used on bottom head)	1
37	Hexagon Socket Nyloc Grubscrew M10 x 20mm long	8
38	Clamping Slug	8
39	Hexagon Socket Grubscrew M6 x 25mm long	2
40	Hexagon Socket Grubscrew M6 x 6mm long	2
41	Hexagon Socket Butt Screw M8 x 20 long	2
42	Locating Pin dia 6mm	1
43	Hexagon Socket Capscrew M8 x 20mm long	4
44	Plain Washer M12	1
45	Locknut M12 x 1.0 pitch	1
46	Hexagon Socket Capscrew M8 x 25mm long	4
47	Locknut M15 x 1.0 pitch	1
48	Special Stud for Motor Fixing	4
49	Tension Pin dia 8mm x 24mm long	2
50	Hexagon Socket Capscrew M10 x 12mm long	2
51	Cover	1

Note: Except for items 1, 5 and 51 quantities are per head

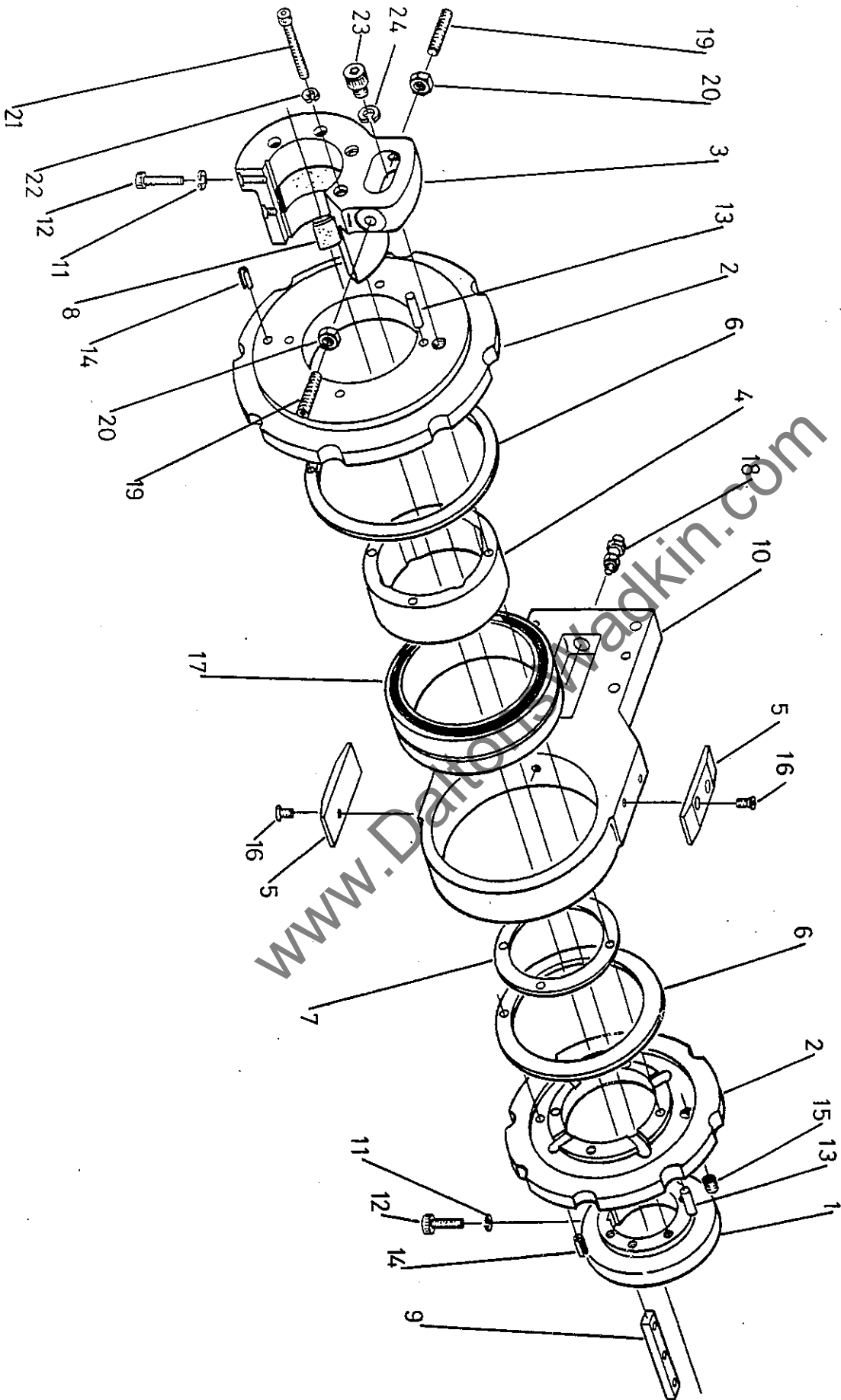

FIG 5 DRIVEN SPROCKET



5 DRIVEN SPROCKET

Ref	Description	No. Off
1 WAA 118	Feed Chain Sprocket Clamp Plate 2	1
- 2	Feed Chain Sprocket	2
3 WAA 107	Feed Chain Drive Hub 2	1
- 4	Feed Chain Sprocket Hub	1
* 5 WAA 208	Chordal Action Guides 8	2 WAA 208
- 6	Sprocket Thrust Ring	2 WAA 231
- 7	Feed Chain Sprocket Shims	As required
8 WAA 283	Strip Bearing 2	1
9 WAA 123	Feed Chain Sprocket Key WAA 123 2	1
10 WAA 113	Feed Chain Sprocket Mounting Plate	1
11 KOS 28153	Spring Washer M6 4	2
12 KOS 25170	Hexagon Socket Capscrew M6 x 40mm long 4	2
13 KOS 29129	Dowel dia 6mm x 20mm long 8	8
14 KOS 20474	Tension Pin dia 4mm x 10mm long 4	2
15 KOS 26136	Hexagon Socket Grubscrew M10 x 10mm long 2	1
* 16 KOS 25321	Hexagon Socket Countersunk Screw M6 x 12mm long 16	4
17 K0613126	Roller Bearing 'INA' NA-4828	1
18 K3062633	Non Return Oil Flow Unit 2	1
19 KOS 26174	Hexagon Socket Grubscrew M8 x 30mm long 4	2
20 KOS 27109	Locknut M8 4	2
21 KOS 25199	Hexagon Socket Capscrew M8 x 80mm long 12	6
22 KOS 28154	Spring Washer M8 12	6
23 KOS 25206	Hexagon Socket Capscrew M10 x 12mm long 2	1
24 KOS 28155	Spring Washer M10 2	1

NOTE: Quantities are per assembly

~~7~~ WAA 209 0.001"
 WAA 210 0.002"
 WAA 211 0.003"
 WAA 212 0.005"
 WAA 213 0.010"

} FOR ITEM 5.

ITEM 7

- WAA 274
- 275
- 276
- 277
- 278



SECTION 5

ILLUSTRATED PARTS LIST

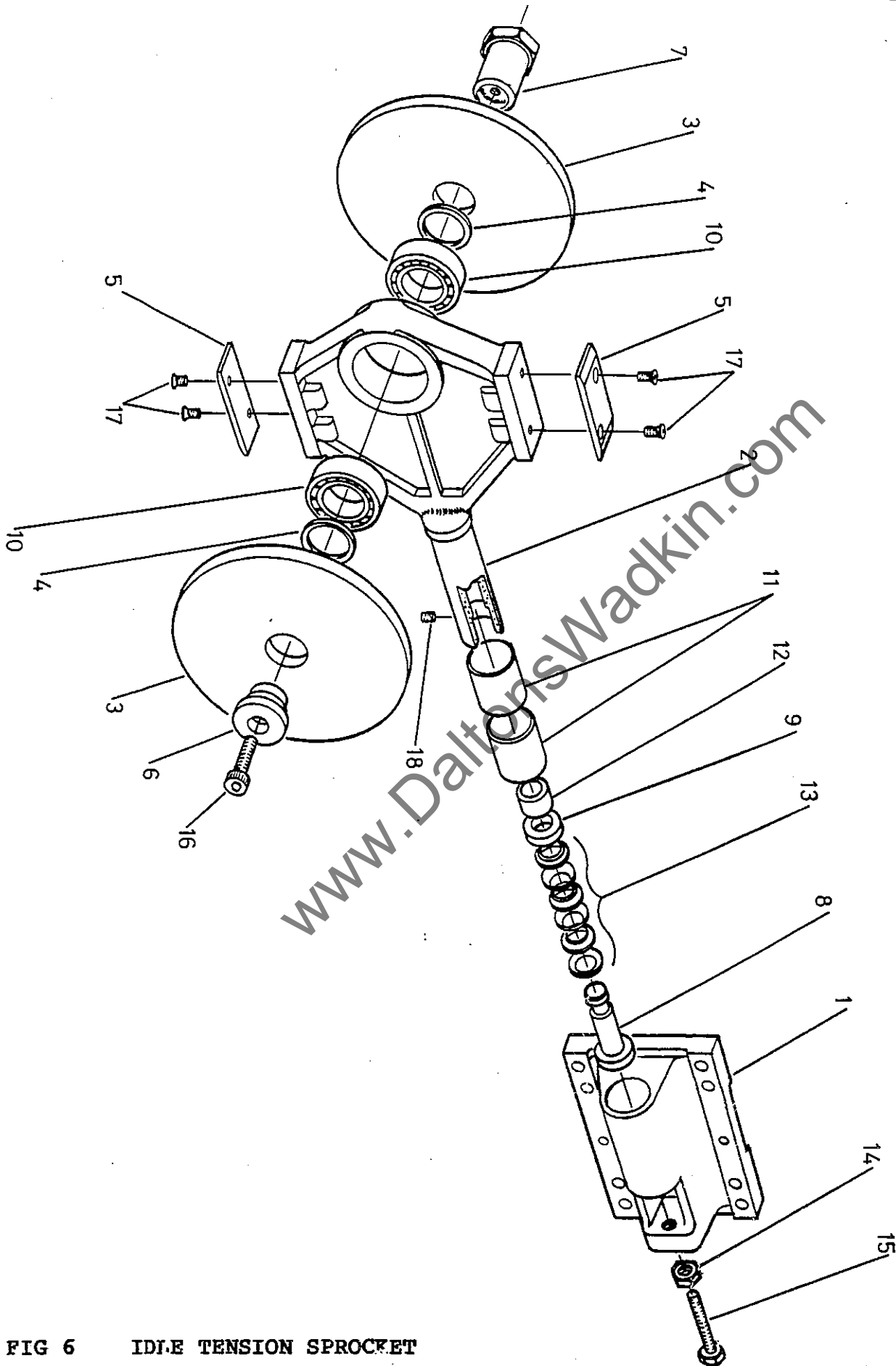

FIG 6 IDLER TENSION SPROCKET

6 IDLE TENSION SPROCKET

Ref	Description	No. Off
1 WMA 114	Feed Chain Tension Bracket 2	1
2 WMA 115	Feed Chain Front Sprocket Bracket 2	1
3 WMA 117	Front Idler Sprocket	2
4 WMA 122	Idler Sprocket Spacer	2
* 5 WMA 208	Chordal Action Guides	2
6 WMA 121	Idler Sprocket Spindle Clamp 2	1
7 WMA 120	Idler Sprocket Spindle 2	1
8 WMA 336	Feed Chain Tension Spindle 2	1
9 WMA 206	Feed Chain Tension Spindle Washer 2	1
10	Ball Bearing 'SKF' 6008 2RS	2
11 KOS31640	Bush 46mm O/D x 40mm I/D x 50mm long 4	2
12 KOS31576	Bush 25mm O/D x 20mm I/D x 25mm long 2	1
13 K3073484	Disc Spring (Stacked in Series) 1 2	6
14 KOS27104	Nut M12 2	1
15 KOS25235	Hexagon Head Setscrew M12 x 50mm long 12	1
16 KOS25232	Hexagon Socket Capscrew M12 x 35mm long 2	1
* 17 KOS25164	Hexagon Socket Countersunk Screw M6 x 12mm long	4
18 KOS26161	Socket Head Grubscrew M6 x 10mm long 2	1

NOTE: Quantities are per assembly

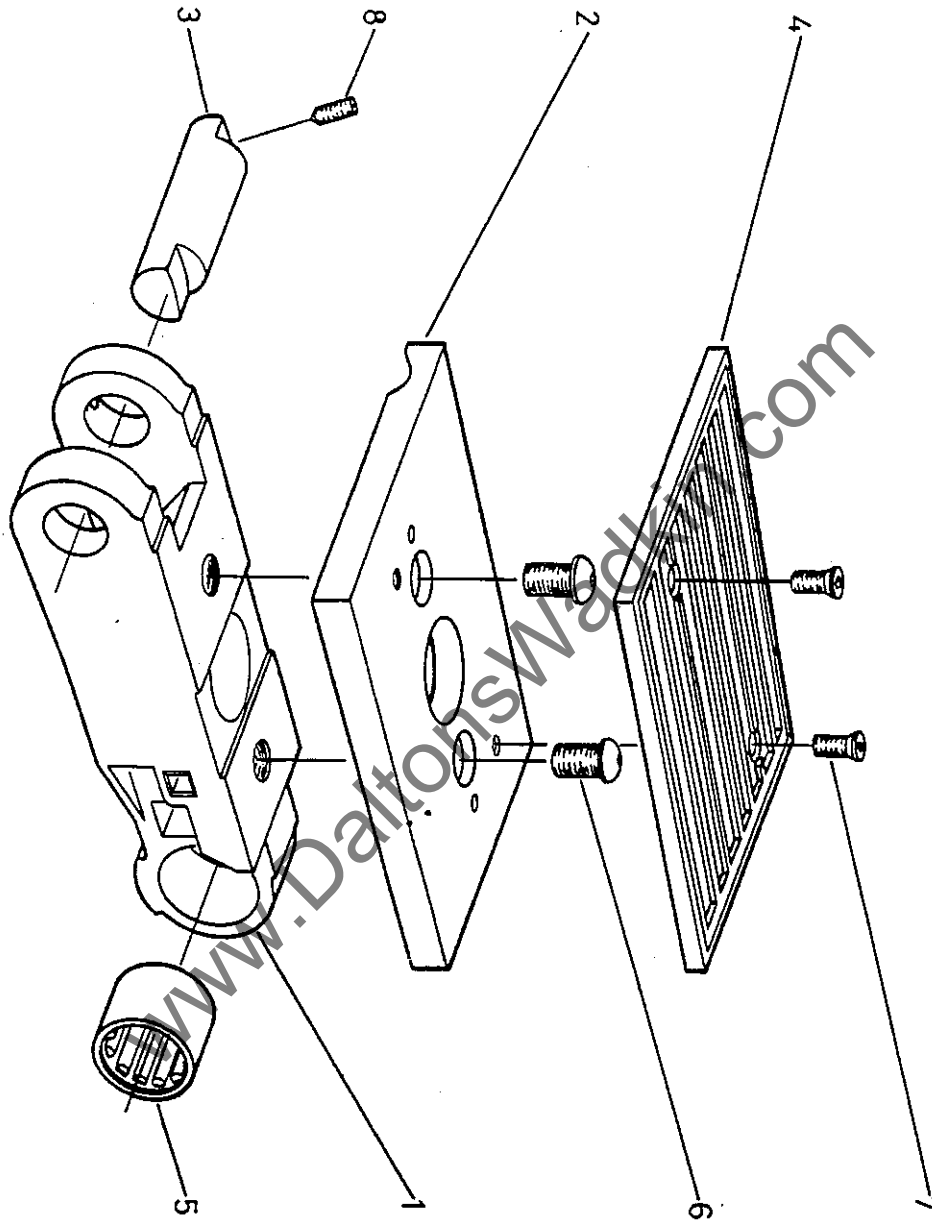

FIG 7 PLAIN CHAIN LINK

7 PLAIN CHAIN LINK

Ref	Description	No. Off
1	Chain Link	1
2	Guide Pad WAA 178.	1
3	Chain Axle	1
4	Top Guide Pad (Rubber) WAA 158/159	1
	Top Guide Pad (Steel)	1
5	Needle Roller Bearing 'INA' HK2016 2RS	1
6	Hexagon Socket Button Head Screw M8 x 20mm long	2
7	Hexagon Socket Countersunk Screw M6 x 12mm long	2
8	Hexagon Socket Nyloc Dog Point Grubscrew M6 x 12mm long	1K 3072536

NOTE: Quantities are per link

www.DaltonsWadkin.com

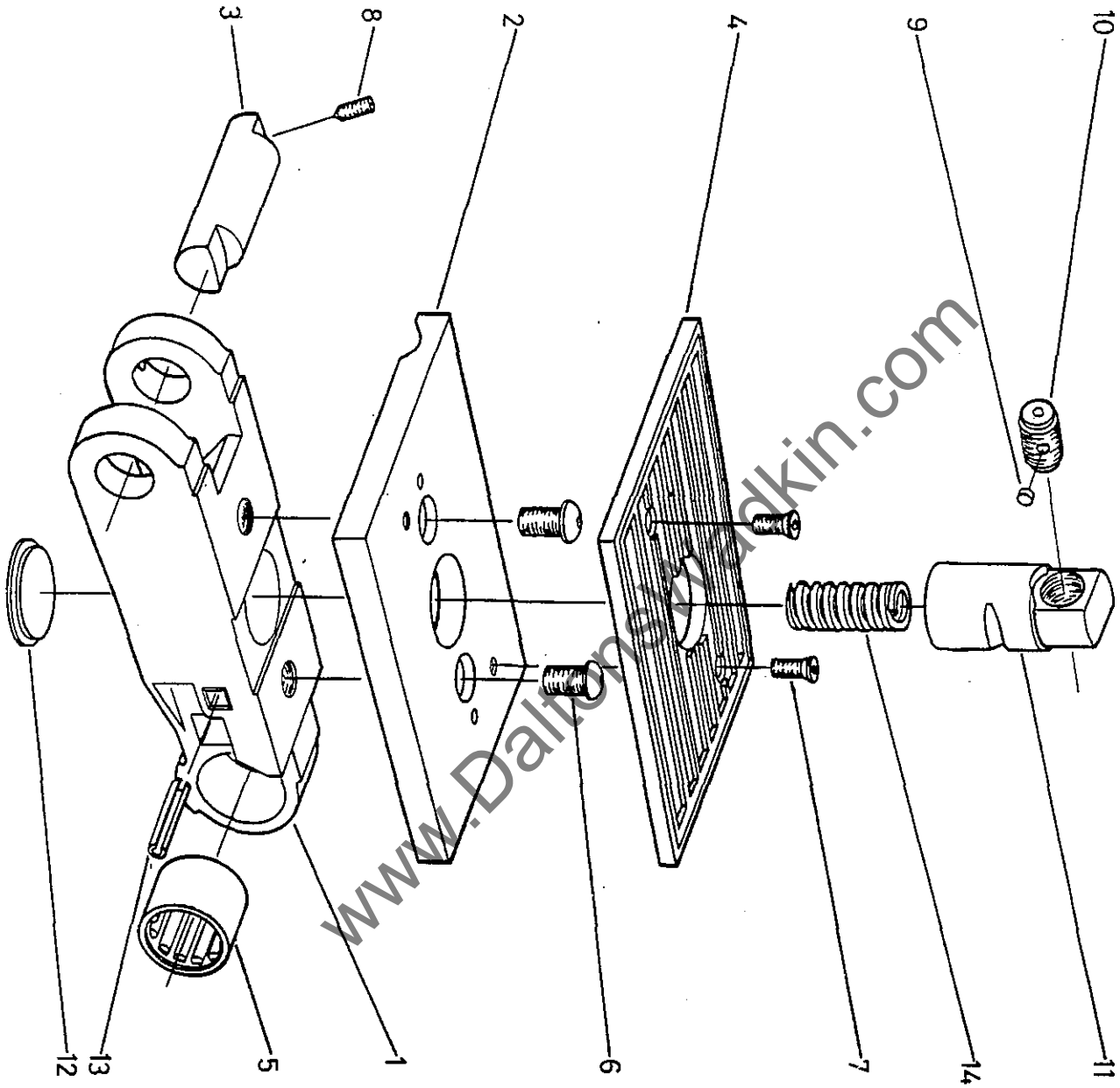

FIG 8 DISAPPEARING DOG CHAIN LINK

8 ^{CHAIN} ~~DISAPPEARING DOG CHAIN~~ LINK

Ref	Description	No. Off
1 ✓	Chain Link WAA 330 330	1
2 ✓	Guide Pad WAA 178	1
3 ✓	Chain axle WAA 341	1
4	Top Guide Pad (Rubber) WA 159	1
✓	Top Guide Pad (Steel) WA. 161	1
5 ✓	Needle Roller Bearing 'INA' HK2016 2RS K06.15.140	1
6 ✓	Hexagon Socket Button Head Screw M8 x 20mm long	2 K3072971
7 ✓	Hexagon Socket Countersunk Screw M6 x 12mm long	2 K0525324
8 ✓	Hexagon Socket Nyloc Dog Point Grubscrew M6 x 12mm long K3072886	1
* 9	Nyloc Insert WAA 510	1
* 10 ✓	Adjusting Screw WAA 198	1
11 ✓	Disappearing Dog WAA 540	1
12 ✓	Wahser WASHER DP 18+ * WAA 541	1
13 ✓	Tension Pin dia 6mm x 32mm long K0520526	1
14 ✓	Compression Spring 'Entex' ETS 93 K7-73964	1

www.DaltonsWadkin.com

PWOODS 90 Amend 19/6/91

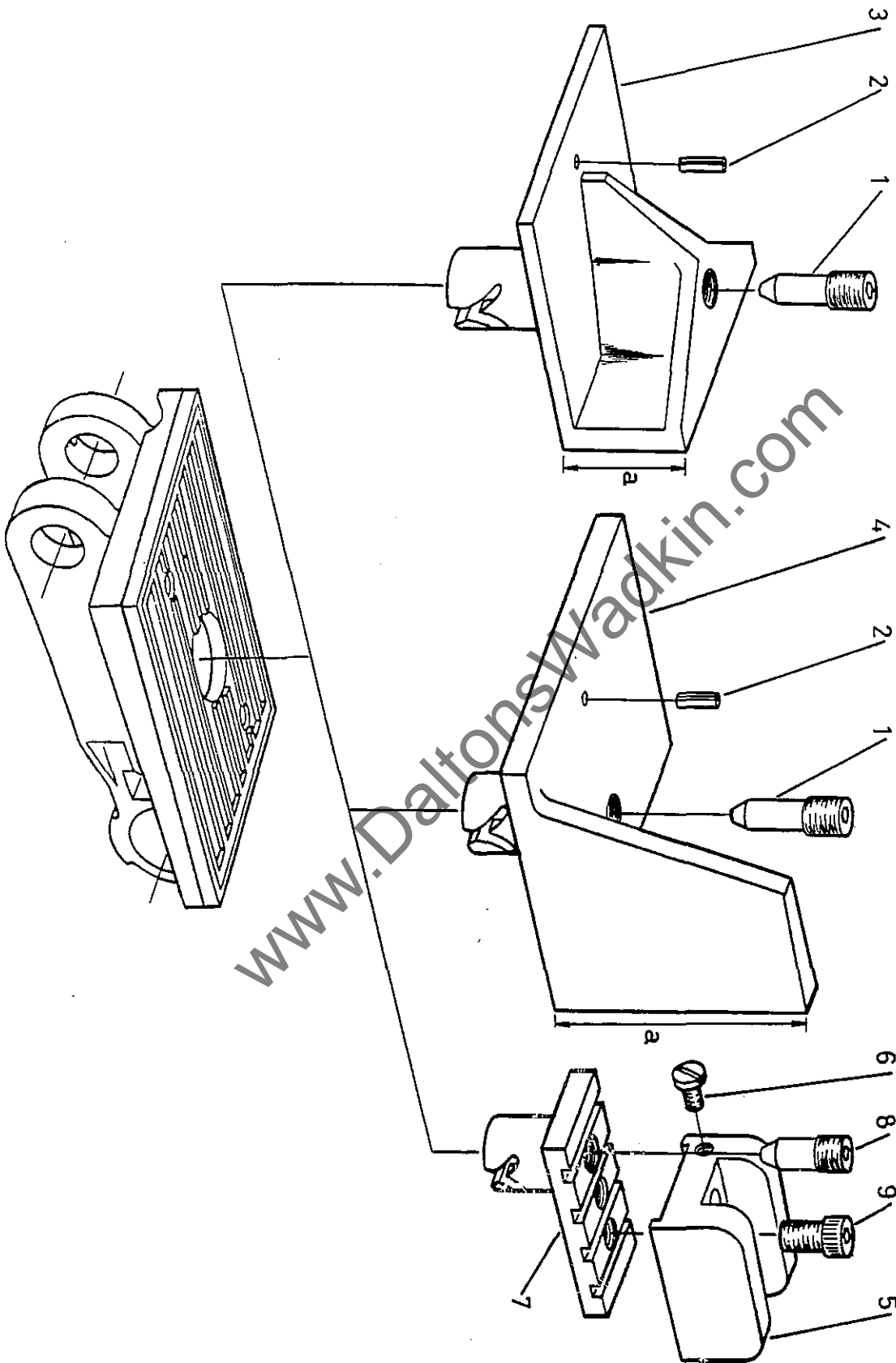

FIG 9 FLAT BACK, FINGER AND TRAPPING DOGS

9 FLAT BACK, FINGER AND TRAPPING DOGS

Ref	Description	No. Off
1	Clamp Screw	
2	Tension Pin dia 6mm x 12mm long	
3	Flat Back Dog	
4	Finger Dog	
5	Trapping Dog Adjuster	
6	Adjusting Screw for Trapping Dog	
7	Trapping Dog Body	
8	Clamp Screw	
9	Hexagon Socket Capscrew M12 x 25mm long	

NOTE: When ordering 'Flat Back or 'Finger Dogs' quote height 'a' of dog

www.DaltonsWadkin.com

SECTION 5

ILLUSTRATED PARTS LIST

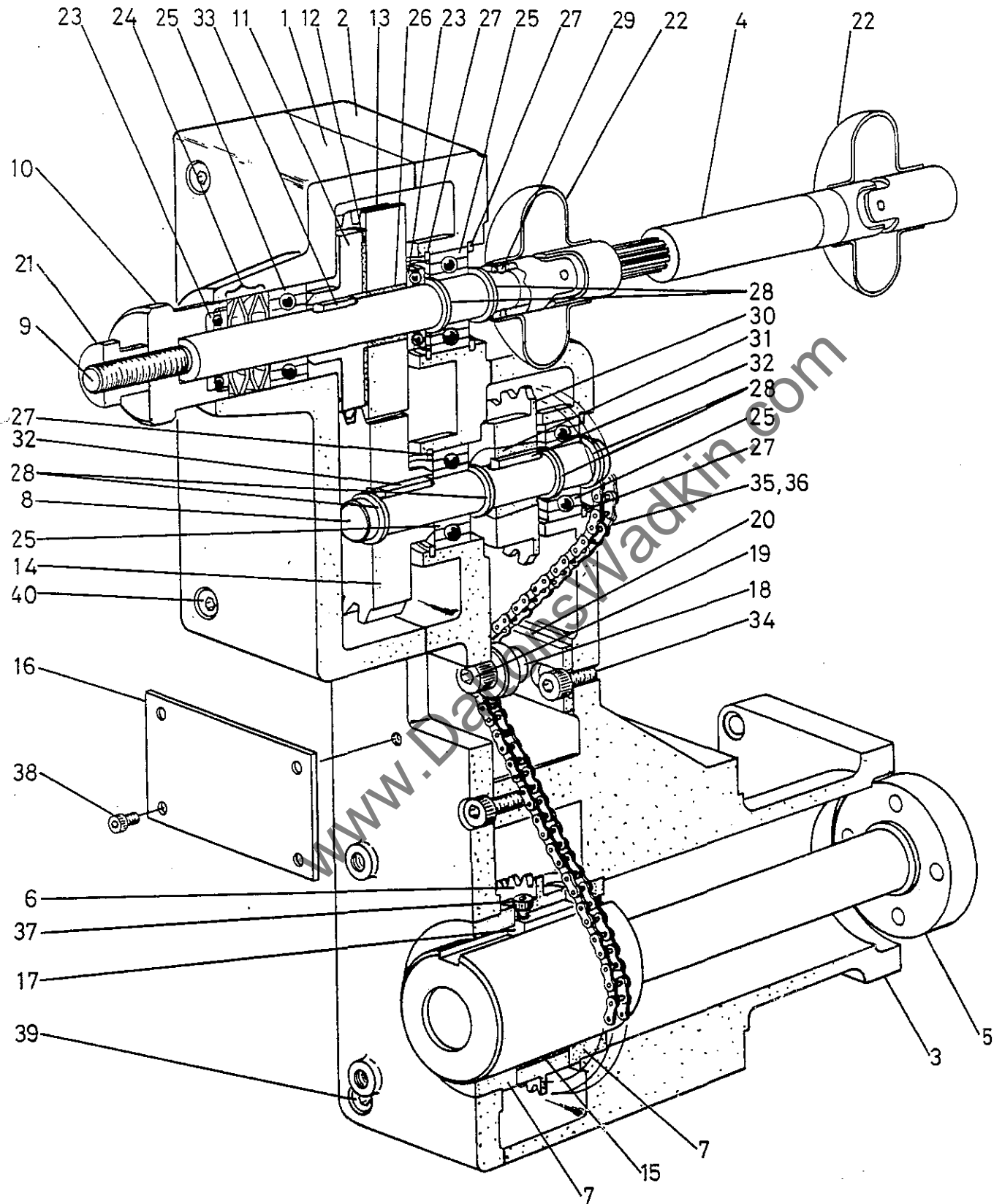

FIG 10 TOP PRESSURE DRIVE UNIT ASSEMBLY

10 TOP PRESSURE DRIVE UNIT ASSEMBLY

Ref	Description	No. Off
1	Front Drive Housing	1
2	Intermediate Housing	1
3	Drive Housing	1
4	Telescopic Drive Shaft <i>WAA410</i>	1
5	Backshaft Extension	1
6	Chain Wheel	1
7	Backshaft Bush	2
8	Gear Shaft	1
9	Clutch Shaft (with left or right hand thread)	1
10	Top Pressure Drive Adjusting Nut (left or right hand thread)	1
11	Clutch Plate	1
12	Clutch Pad	1
13	Driven Gear	1
14	Drive Gear	1
15	Strip Bearing	1
16	Cover for Tensioner Access	1
17	Drive Key	1
18	Tensioner Wheel	1
19	Pivot Pin <i>WAA405</i>	1
20	Chain Tensioner <i>WAA402</i>	1
21	Top Pressure Drive Lock Nut (left or right hand thread)	1
22	'HUCO' Garter Type T Size 32 <i>K3037141</i>	2
23	Thrust Bearing 'RHP' 51105	2
24	Disc Spring 50mm O/D x 25.4mm I/D x 15mm	4
25	Ball Bearing 'RHP' 6205-2RS	4
26	Bush 30mm O/D x 25mm I/D x 20mm long	1
27	Internal Circlip dia 52mm	4
28	External Circlip dia 25mm	6
29	Taper Pin	1
30	Sprocket 'Fenner' 41-21	1
31	Taper Lock Bush 1610 25mm	1
32	Key 8mm x 7mm x 25mm	2
33	Key 8mm x 7mm x 20mm	1
34	Hexagon Socket Capscrew M8 x 16mm long	1
35	Connection link No. 26 110046 CHN	1

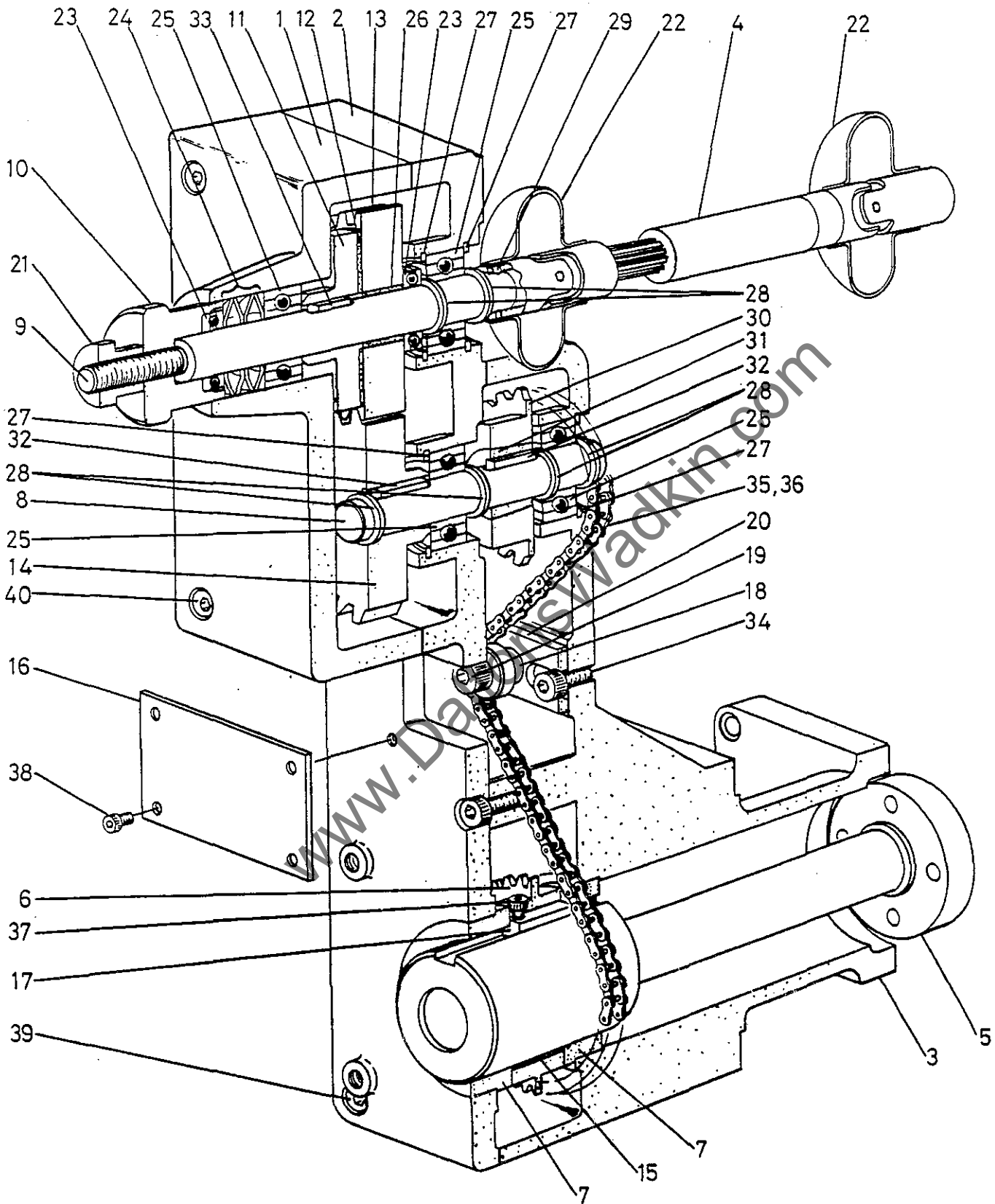

FIG 10 TOP PRESSURE DRIVE UNIT ASSEMBLY



10 TOP PRESSURE DRIVE UNIT ASSEMBLY Cont

Ref	Description	No. Off
36	Chain 1/2" pitch 68 links	1 1 301048
37	Hexagon Socket Capscrew M5 x 16mm long	1
38	Hexagon Socket Capscrew M4 x 8mm long	4
39	Hexagon Socket Capscrew M8 x 20mm long	3
40	Hexagon Socket Capscrew M8 x 60mm long	4

www.DaltonsWadkin.com

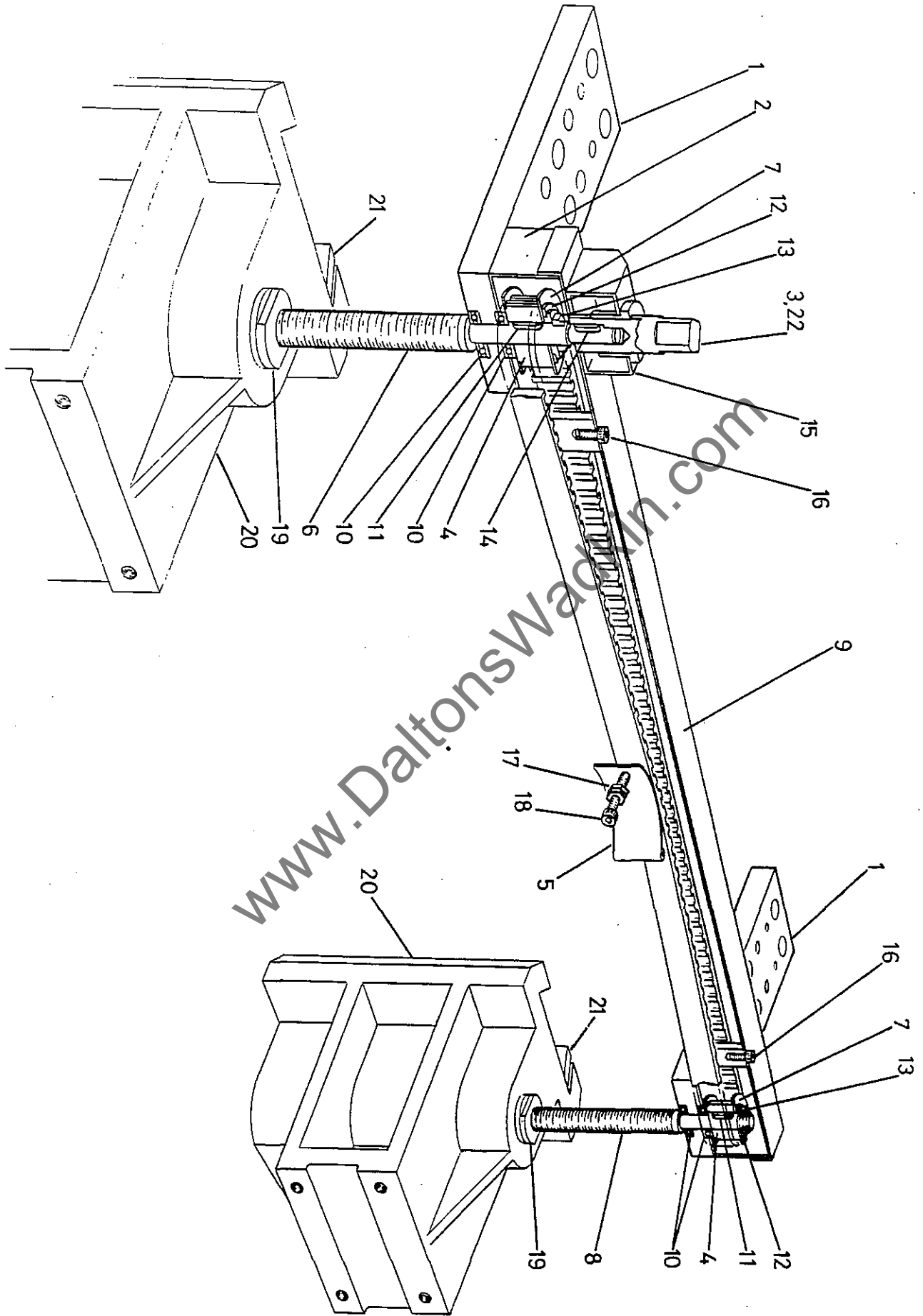

www.DaltonsWadkin.com

FIG 11 TOP PRESSURE ADJUSTMENT - DOUBLE COLUMN

11 TOP PRESSURE ADJUSTMENT - DOUBLE COLUMN

Ref	Description	No. Off
1	Top Pressure Anchor Plate	2
2	Dual drive Box	1
3	Handle Adaptor	1
4	Timing Pulley	2
5	Top Pressure Belt Adjuster	1
6	Top Pressure Leadscrew	1
7	Timing Pulley Flange	2
8	Top Pressure Leadscrew	1
9	Dual Drive Box Cover	1
10	Thrust Bearing 'SKF' 51102	4
11	Key 5mm x 5mm x 20mm	2
12	External Circlip dia 30mm	2
13	Special Locking Nut M15 x 1.0p	2
14	Key 4mm x 4mm x 20mm	1
15	'SIKO' Digital Readout 0904:1 (Imperial or Metric)	1
16	Hexagon Socket Capscrew M6 x 12mm long	2
17	Lock Nut M6	1
18	Hexagon Socket Capscrew M6 x 50mm long	1
19	Nut Insert	2
20	Top Pressure Slide (Fixed side movement - See No. 13 for Adjustable side movement)	2
21	Gib Strip for slide	2
22	Hexagon Socket Grubscrew M6 x 6mm long	1

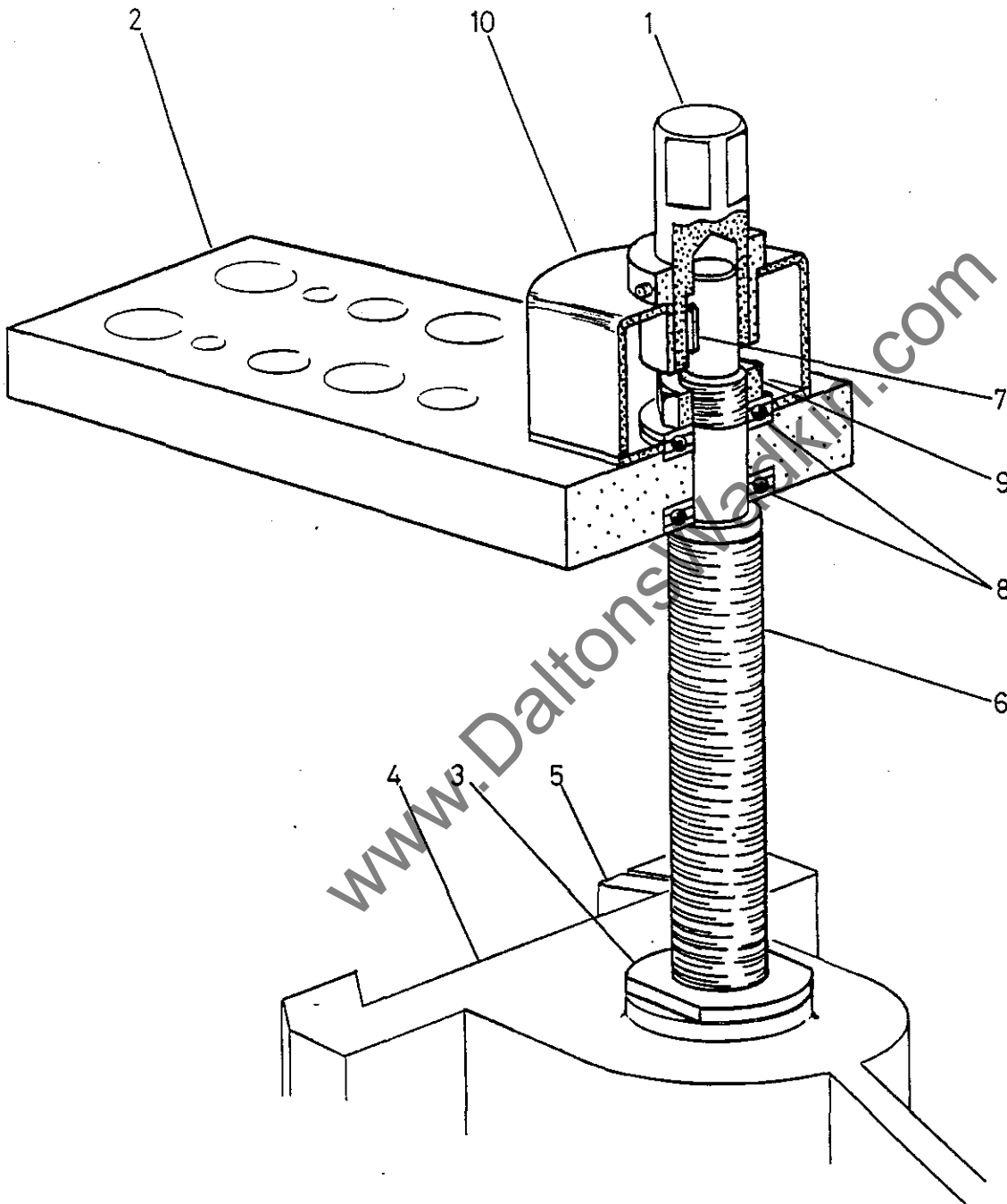

FIG 12 TOP PRESSURE ADJUSTMENT - SINGLE COLUMN

12 TOP PRESSURE ADJUSTMENT - SINGLE COLUMN

Ref	Description	No. Off
1	Square Adaptor	1
2	Top Pressure Anchor Plate	1
3	Rise and Fall Nut Insert	1
4	Top Pressure Slide (Fixed side movement - See No. 13 for Adjustable Side Movement)	1
5	Gib Strip for Slide	1
6	Top Pressure Lead Screw	1
7	Key 4mm x 4mm x 20mm	1
8	Thrust Bearing 'SKF' 51102	2
9	Special Locking Nut M15 x 1.0p	1
10	'SIKO' Digital Readout 0904:1 (Imperial or Metric)	1

www.DaltonsWadkin.com

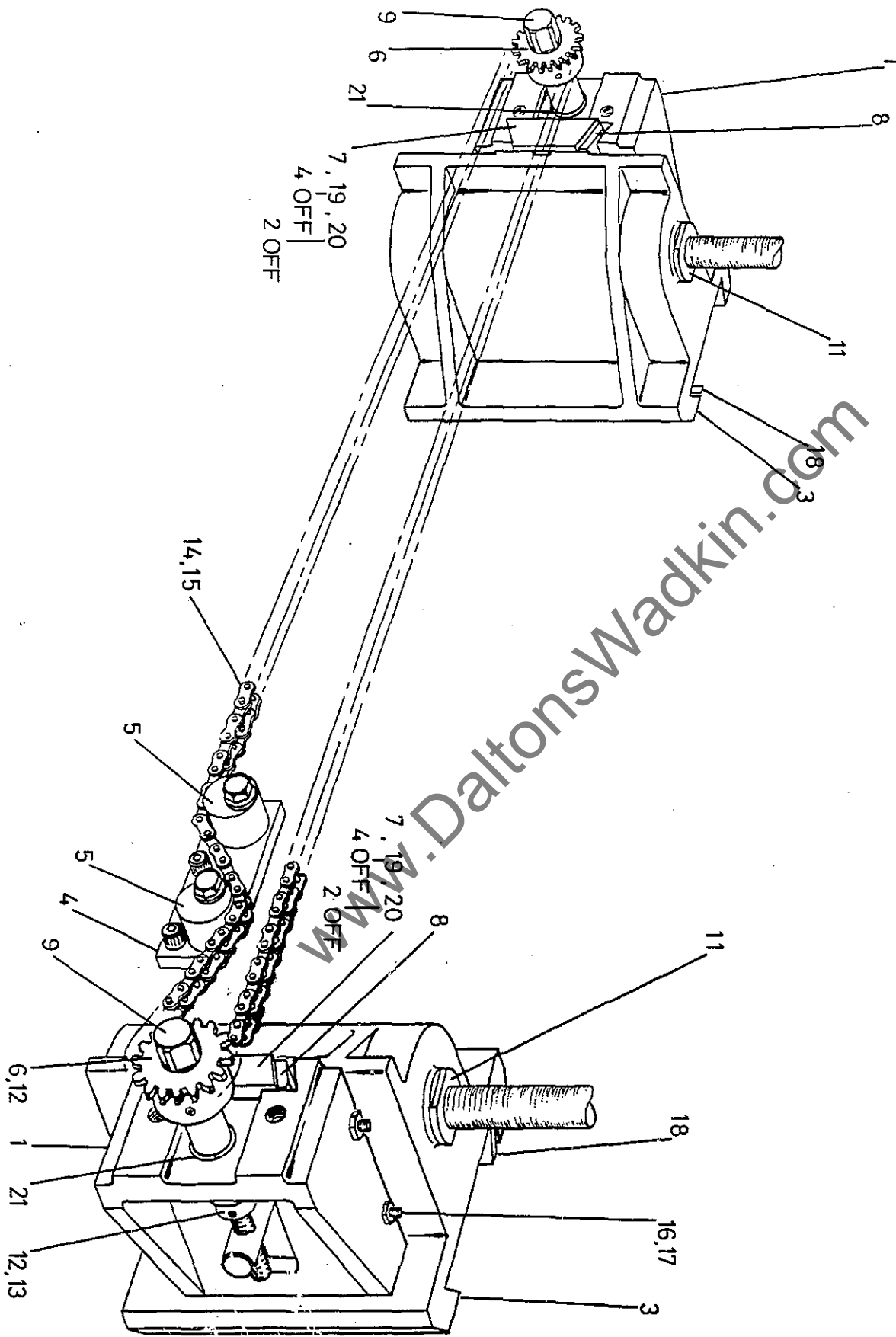

FIG 13 SIDE ADJUSTMENT - RCP PRESSURES

13 SIDE ADJUSTMENT - TOP PRESSURES

Ref	Description	No. Off
1	Top Pressure Adjustment Slide R.H.	1
2	Top Pressure Adjustment Slide L.H.	1
3	Top Pressure Slide	2
4	Tensioner Plate	1
5	Chain Tensioner	2
6	Sprocket	2
7	Top Pressure Adjustment Slideway	2
8	Gib Strip	2
9	Screw	2
10	Slide Nut	2
11	Rise and Fall Nut Insert	2
12	Collar 25mm O/D, 12mm I/D	2
13	Hexagon Socket Grubscrew M6 x 6mm long	4
14	Chain 3/8" pitch 197 pitches	1
15	Chain Connecting Link	1
16	Hexagon Socket Grubscrew M10 x 35mm long	4
17	Locknut M10	4
18	Gib Strip	2
19	Hexagon Socket Capscrew M10 x 30mm long	8
20	Tension Pin dia 8mm x 40mm long	4
21	Plain Washer M12	2

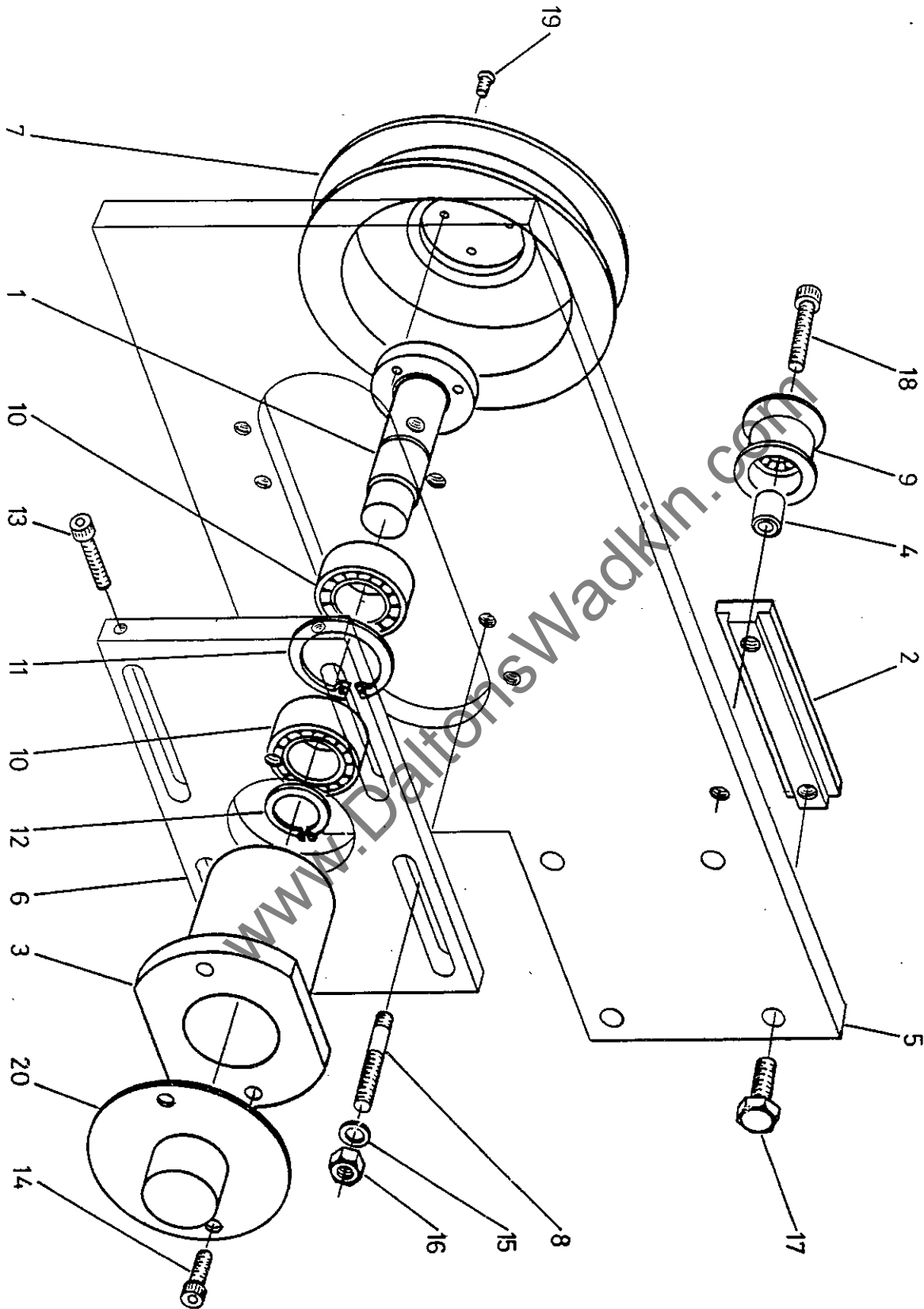

FIG 14 REAR PULLEY - 'V' BELT TOP PRESSURE

14 REAR PULLEY - 'V' BELT TOP PRESSURE

Ref	Description	No. Off
1	Spindle	1
2	Tee Bar	2
3	Spindle Housing	1
4	Idle Roller Spacer	1
5	Rear Plate	1
6	Tension Plate	1
7	Pulley	1
8	Special Stud M10 x 50mm long	4
9	Top Pressure Roller (only available complete with bearing)	1
10	Ball Bearing 'SKF' 6205 - 2RS	2
11	Internal Circlip dia 52mm	1
12	External Circlip dia 25mm	1
13	Hexagon Socket Capscrew M6 x 50mm long	2
14	Hexagon Socket Capscrew M8 x 20mm long	2
15	Plain Washer M10	4
16	Nut M10	4
17	Hexagon Head Setscrew M10 x 25mm long	4
18	Hexagon Socket Capscrew M10 x 45mm long	1
19	Hexagon Socket Countersunk Screw M6 x 10mm long	3
20	Drive Shaft Cover (Not fitted if top pressure are driven)	1

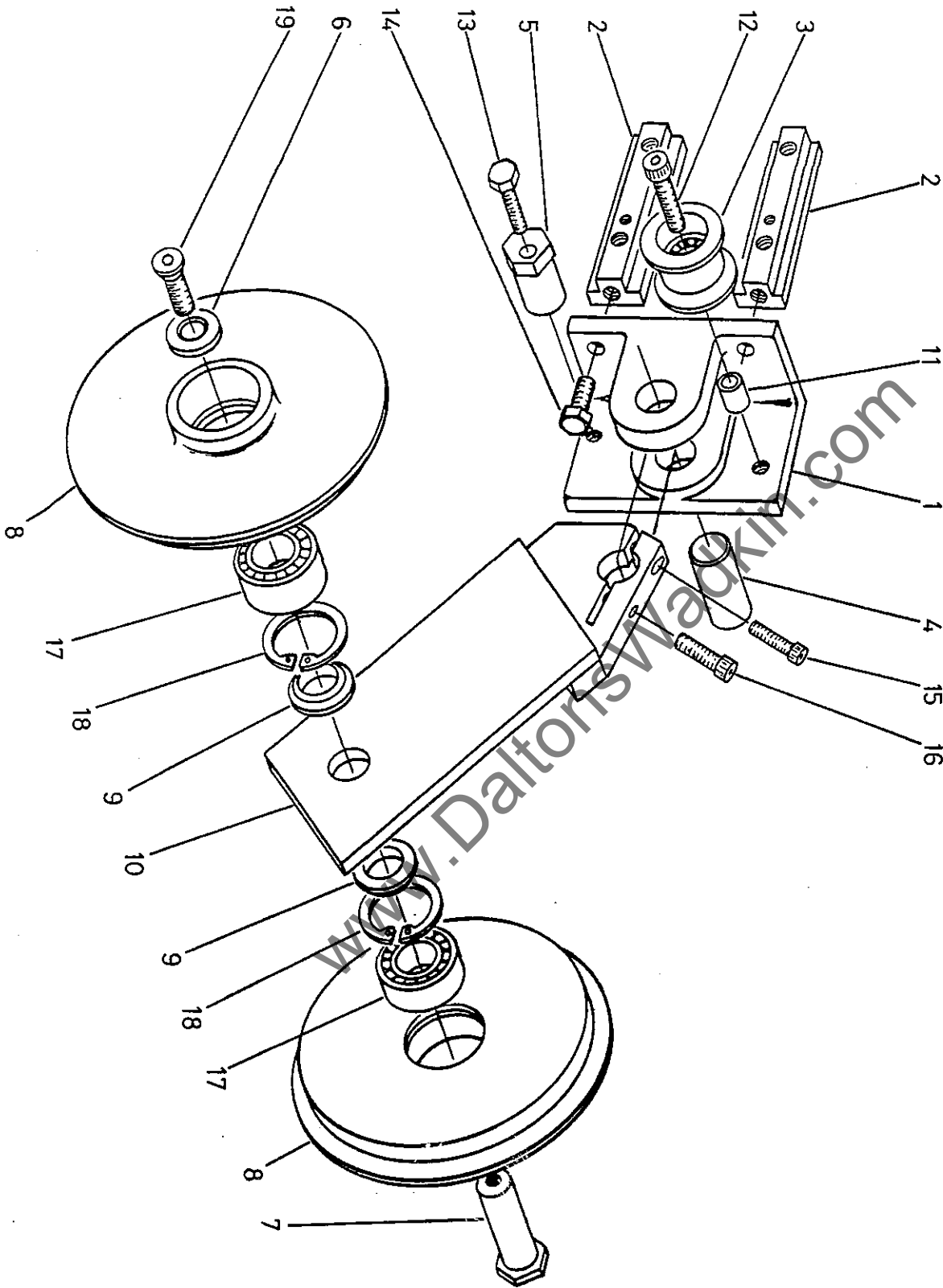

FIG 15 FRONT PULLEY - 'V' BELT TOP PRESSURE

15 FRONT PULLEY - 'V' BELT TOP PRESSURE

Ref	Description	No. Off
1	Pivot Bracket (left hand as shown or right hand)	1
2	Tee Bar	2
3	Top Pressure Roller (complete with bearing)	1
4	Pivot Pin	1
5	Stop Bar	1
6	Bearing Retaining Washer	1
7	Bearing Pin	1
8	Front Pulley Half	2
9	Bearing Spacer	2
10	Pivot Arm (left hand as shown or right hand))	1
11	Idle Roller Spacer	1
12	Hexagon Socket Capscrew M10 x 35mm long	1
13	Hexagon Head Setscrew M8 x 40mm long	1
14	Hexagon Head Setscrew M8 x 20mm long	2
15	Hexagon Socket Capscrew M6 x 25mm long	1
16	Hexagon Socket Capscrew M8 x 40mm long	1
17	Ball Bearing 'SKF'; 6004 - 2RS	2
18	Internal Circlip dia 42mm	2
19	Hexagon Socket Head Countersunk Screw M8 x 20mm long	1

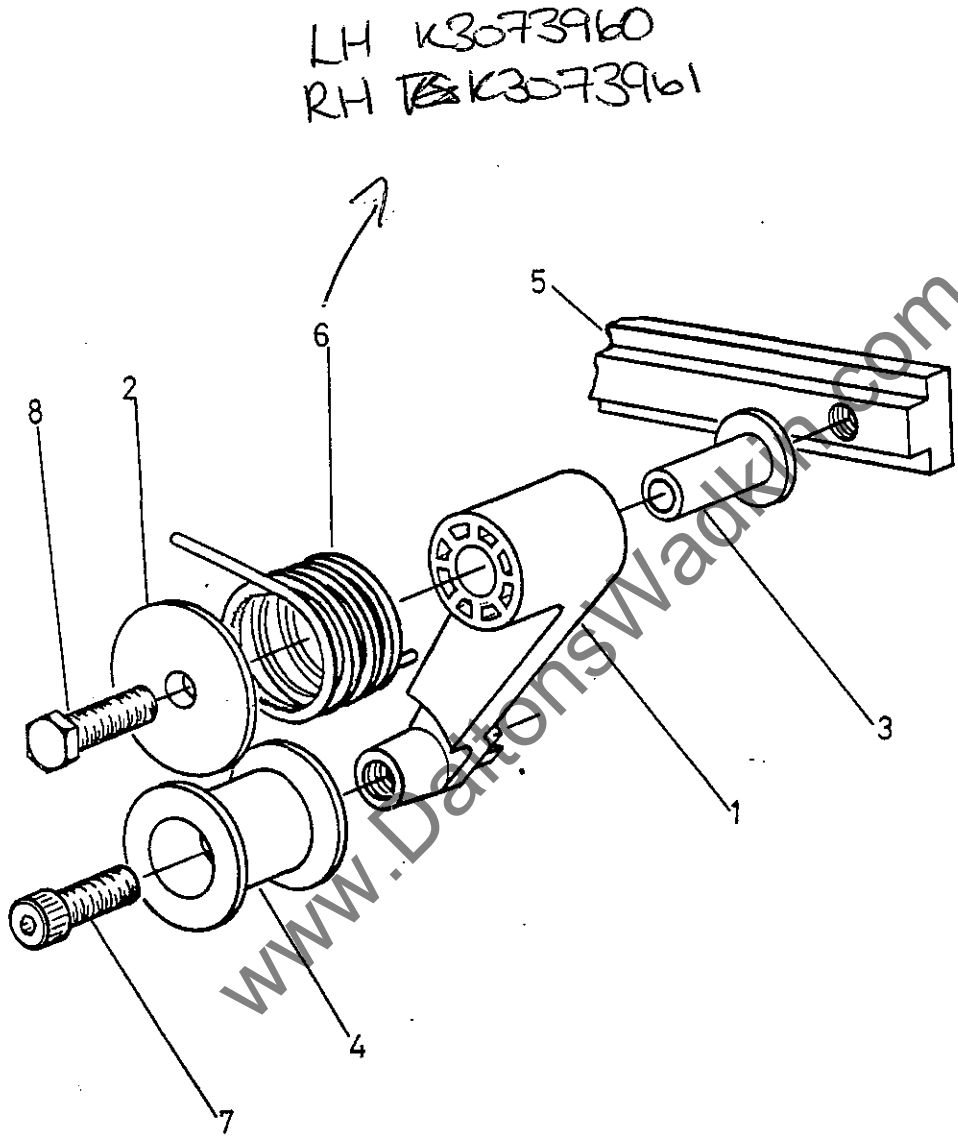

FIG 16 PRESSURE ARM - 'V' BELT TOP PRESSURE



16 PRESSURE ARM - 'V' BELT TOP PRESSRUE

Ref	Description	No. Off
1	Top Pressure Arm DA 106	1
2	Retaining Washer DA 45	1
3	Pressure arm Support DA 43	1
4	Top Pressure Roller (complete with bearing only) DA 20	1
5	Tee Bar	
6	Compression Spring 'Entex' ETS 59 K30.73.454	1
7	Hexagon Socket Capscrew M10 x 35mm long	1
8	Hexagon Head Setscrew M10 x 40mm long	1

NOTE: Quantities are per pressure arm assembly

www.DaltonsWadkin.com

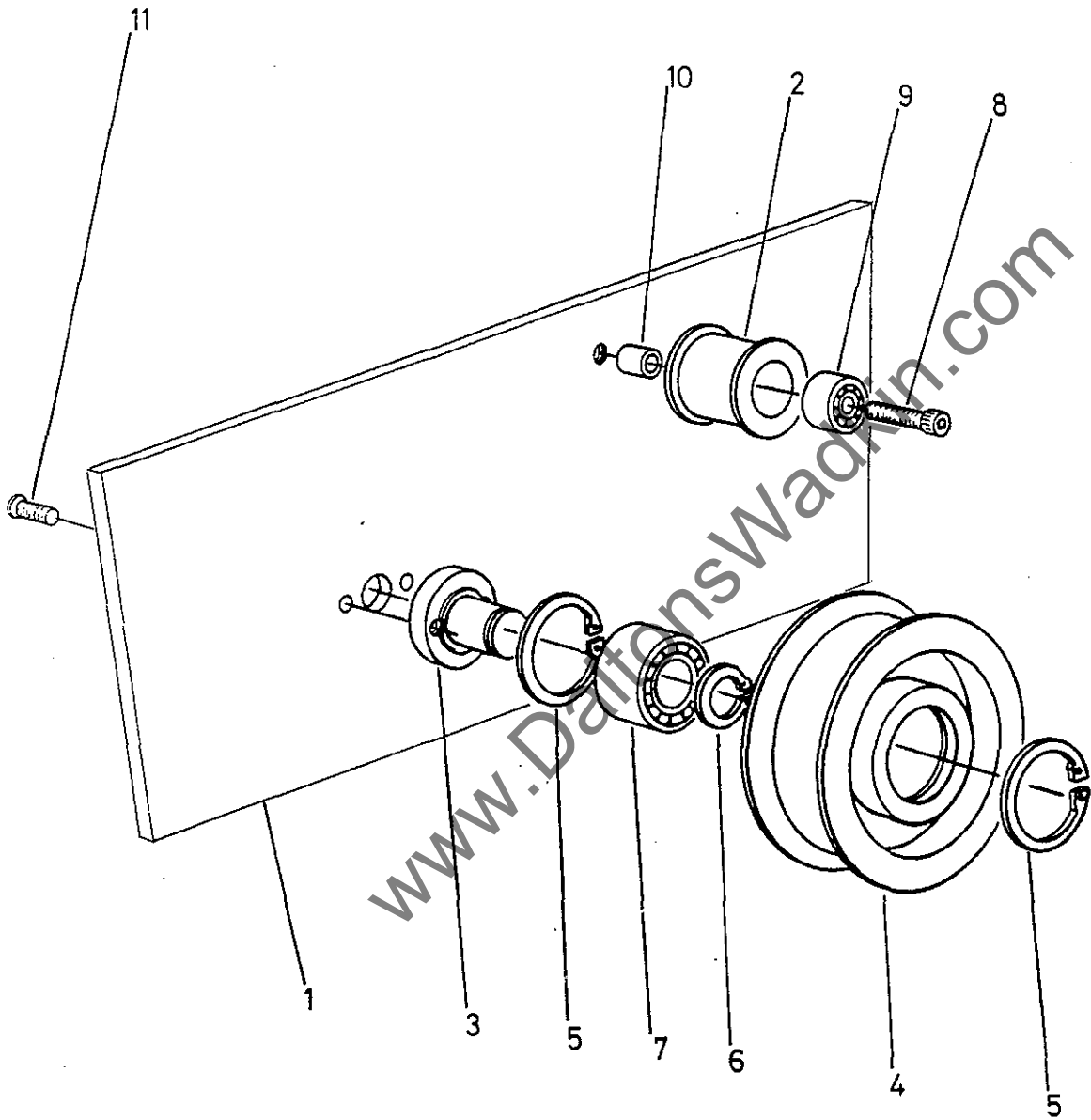

FIG 17. FRONT PULLEY-CATERPILLAR TOP PRESSURE

17 FRONT PULLEY - CATERPILLAR TOP PRESSURE

Ref	Description	No. Off
1	Front Plate (left hand as shown or right hand)	1
2	Idler Pulley	1
3	Spindle	1
4	Pressure Chain Wheel	1
5	Internal Circlip dia 62mm	2
6	External Circlip dia 30mm	1
7	Ball Bearing 'SKF' 6300 2RS	1
8	Hexagon Socket Capscrew M10 x 35m long	1
9	Ball Bearing 'RHP' 6206 - 24W	1
10	Spacer	1
11	Hexagon Socket Countersunk Screw M8 x 20mm long	2

www.DaltonsWadkin.com

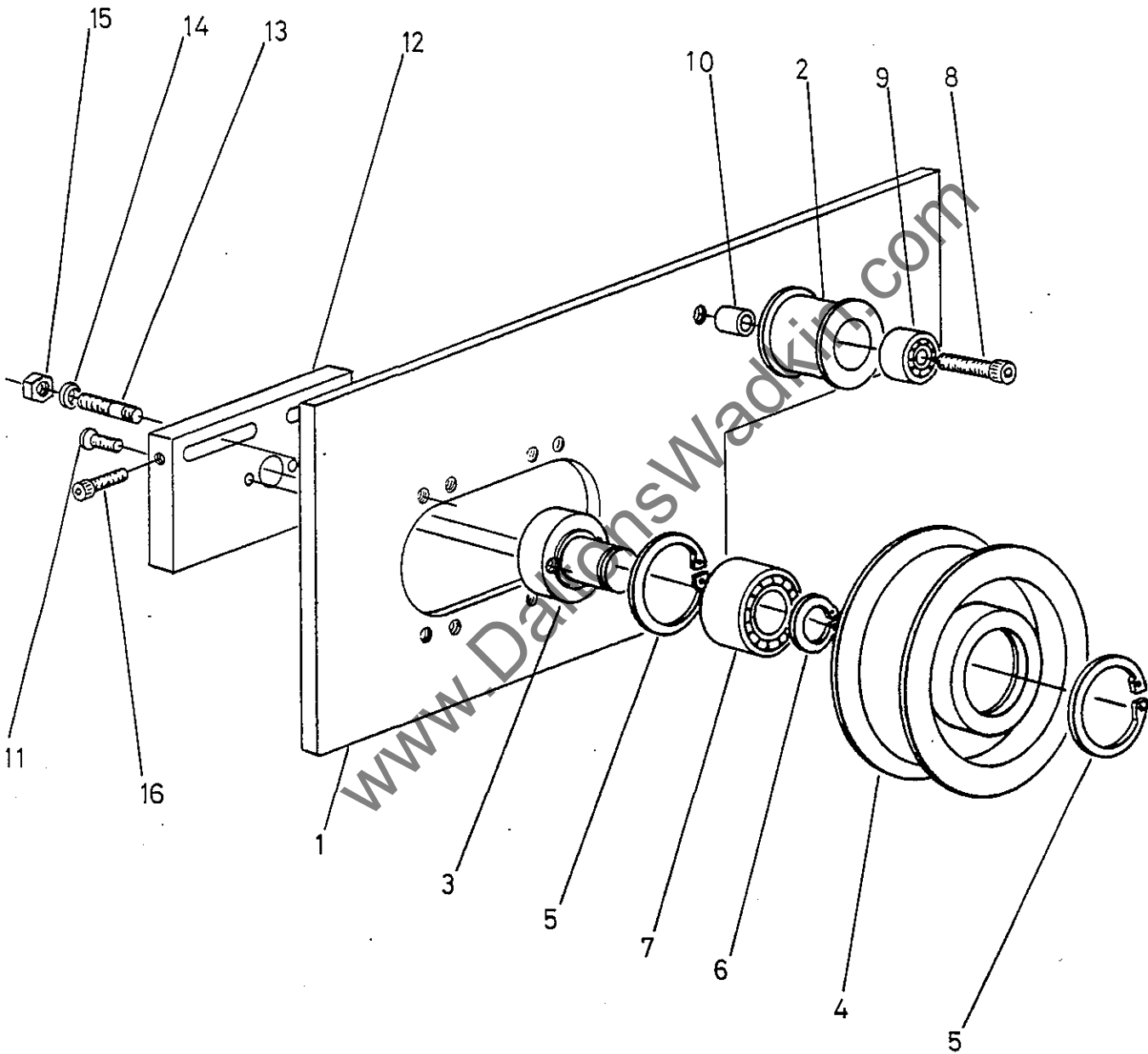

FIG 18 REAR PULLEY-CATERPILLAR TOP PRESSURE

18 REAR PULLEY - CATERPILLAR TOP PRESSURE

Ref	Description	No. Off
1	Rear Plate	1
2	Idler Pulley	1
3	Spindle	1
4	Pressure Chain Wheel	1
5	Internal Circlip dia 62mm	2
6	External Circlip dia 30mm	1
7	Ball Bearing 'SKF' 6300 2RS	1
8	Hexagon Socket Capscrew M10 x 35mm long	1
9	Ball Bearing 'RHP' 6206 - 24W	1
10	Spacer	1
11	Hexagon Socket Countersunk Screw M8 x 20mm long	2
12	Tension Bracket	1
13	Special Stud M10 x 50mm long	2
14	Plain Washer M10	2
15	Nut M10	2
16	Hexagon Socket Capscrew M6 x 50mm long	1

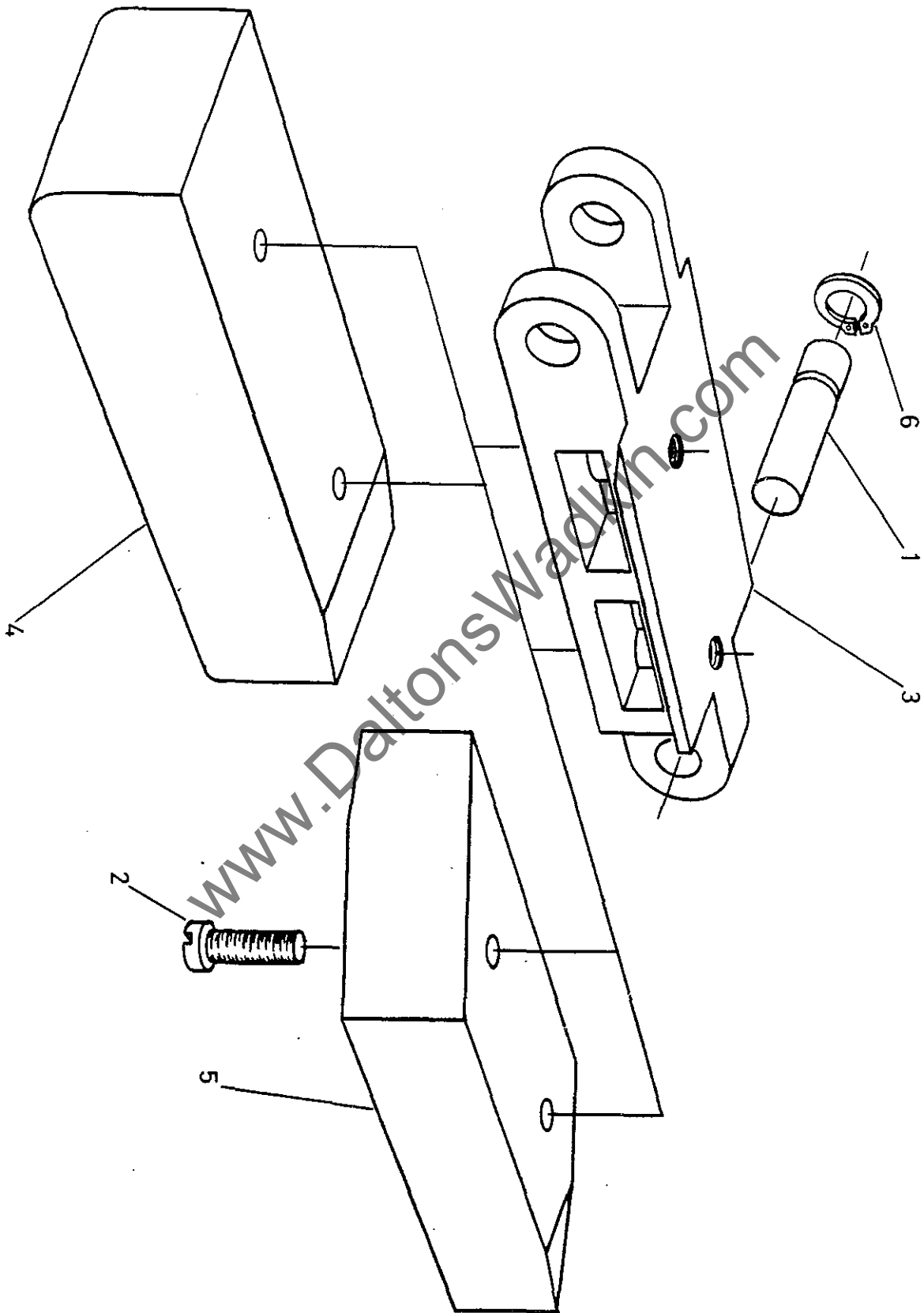

FIG 19 CATERPILLAR PRESSURE PADS



19 CATERPILLAR PRESSURE PADS

Ref	Description	No. Off
1	Chain Pin. DP 2242.	1
2	Screw for Pressure Pad	2
3	Link for Pressure Chain DP 2240.	1
4	Pressure Pad Standard	1
5	Pressure Pad Rhomboidal (left or right hand)	1
6	External Circlip	1

Rail which links goon is
WA 491.

www.DaltonsWadkin.com

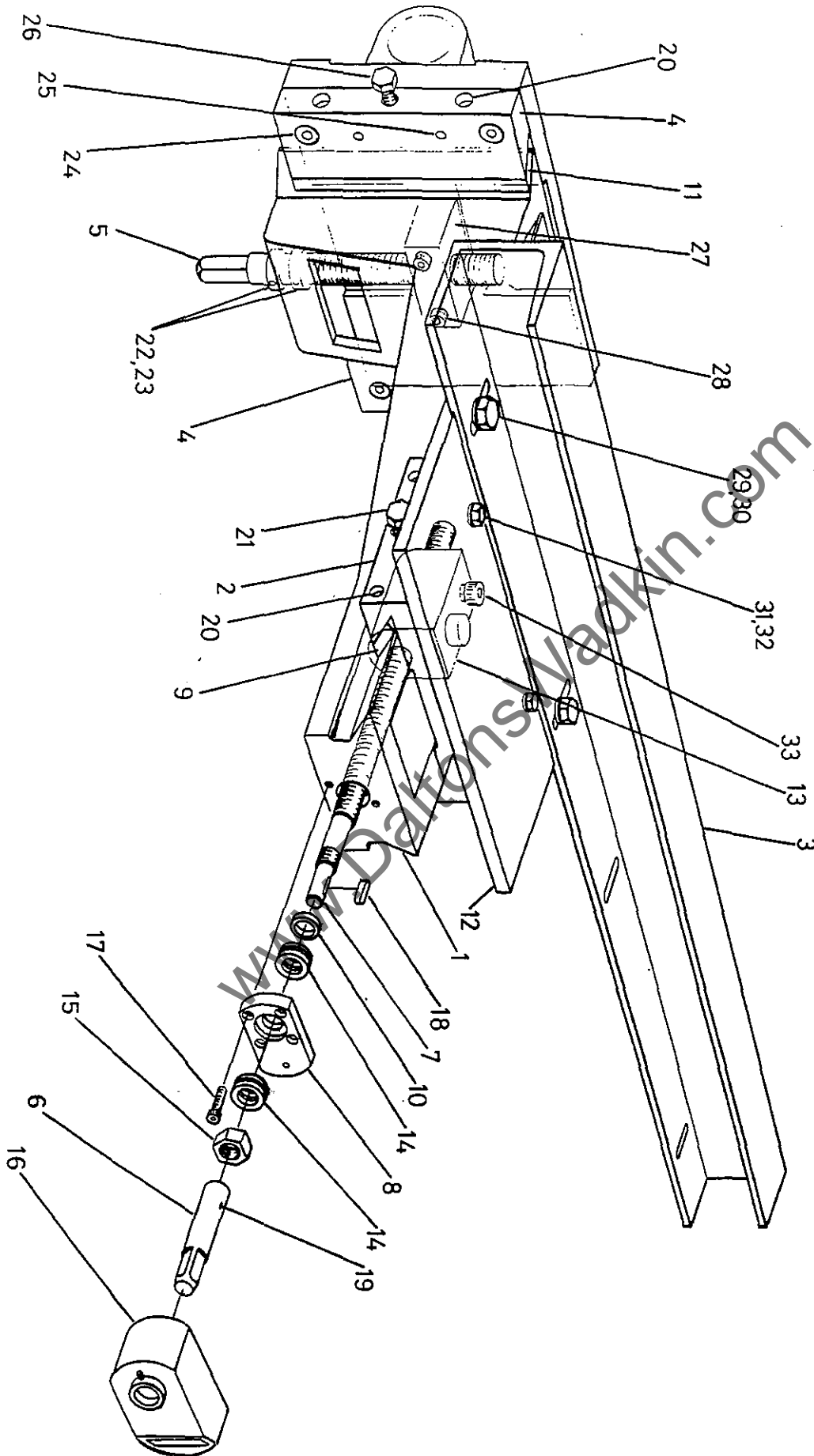

FIG. 20 STANDARD 1.5M INFEED FENCE

20 STANDARD 1.5M INFEED FENCE

Ref	Description	No.Off
1	Fence Adjustment Bracket	1
2	Slide for Fence Adjustment Bracket	1
3	Standard Fence	1
4	Vee Slide	2
5	Fence Screw	1
6	Adaptor	1
7	Top Pressure Leadscrew	1
8	Thrust Plate	1
9	Gib Strip	1
10	Spacer	1
11	Gib Strip	1
12	Fence Plate	1
13	Back Slide Nut	1
14	Thrust Bearing 'SKF' 51102	2
15	Self Locking Nut M15 x 10p	1
16	'SIKO' Digital Readout 09021 (Metric or imperial)	1
17	Hexagon Capscrew M6 x 16mm long	2
18	Key 20mm x 4mm x 4mm	1
19	Hexagon Socket Grubscrew M4 x 6mm long	1
20	Hexagon Socket Grubscrew M10 x 25mm long	2
21	Hexagon Head Setscrew M10 x 35mm long	1
22	Plain Collar 20mm I/D x 32mm O/D x 14mm	2
23	Tension dia 6mm x 30mm long	2
24	Hexagon Socket Capscrew M12 x 55mm long	4
25	Dowel dia 6mm x 30mm long	4
26	Hexagon Head Setscrew M10 x 50mm long	1
27	Nut	1
28	Hexagon Socket Capscrew M8 x 50mm long	1
29	Hexagon Head Capscrew M10 x 16mm long	2
30	Plain Washer M10	2
31	Hexagon Head Setscrew M8 x 25mm long	2
32	Plain Washer M8	2
33	Hexagon Socket Capscrew M8 x 20mm long	1



SECTION 5

ILLUSTRATED PARTS LIST

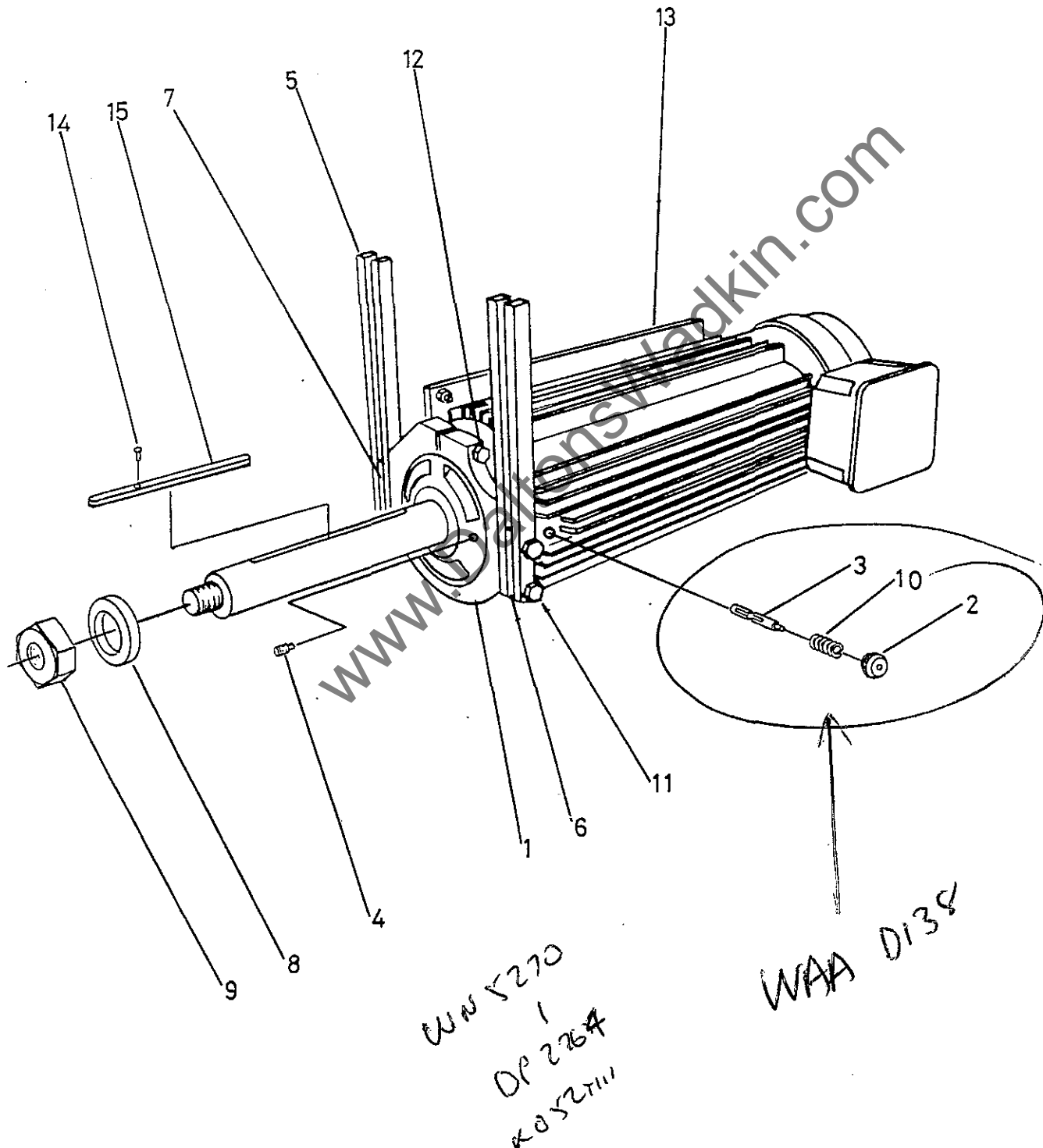

FIG 21 'A' TYPE HEAD



21 'A' TYPE HEAD

Ref	Description	No. Off
1	Support Ring for Guard	1
2	Knob for plunger	1
3	Plunger Barrel	1
4	Half Dog Point Grubscrew 1/4" B.S.W. x 19mm long	1
5	Cutter Guard Support Bar	4
6	Cutter Guard Support Bar Packer (10mm thick)	1
7	Cutter Guard Support Bar Packer (12mm thick)	1
8	Spacer (Various widths and bore sizes)	A/R
9	Spindle Nut (to suit spindle diameter)	1
10	Compression Spring 'Entex' ETS 96	1
11	Hexagon Socket Capscrew M10 x 60mm long	4
12	Hexagon Socket Capscrew M10 x 70mm long	1
13	Motor	1
14	Hexagon Socket Countersunk Screw M5 x 16mm long	1
15	Drive key (To suit spindle)	1

www.DaltonsWadkin.com



SECTION 5

ILLUSTRATED PARTS LIST

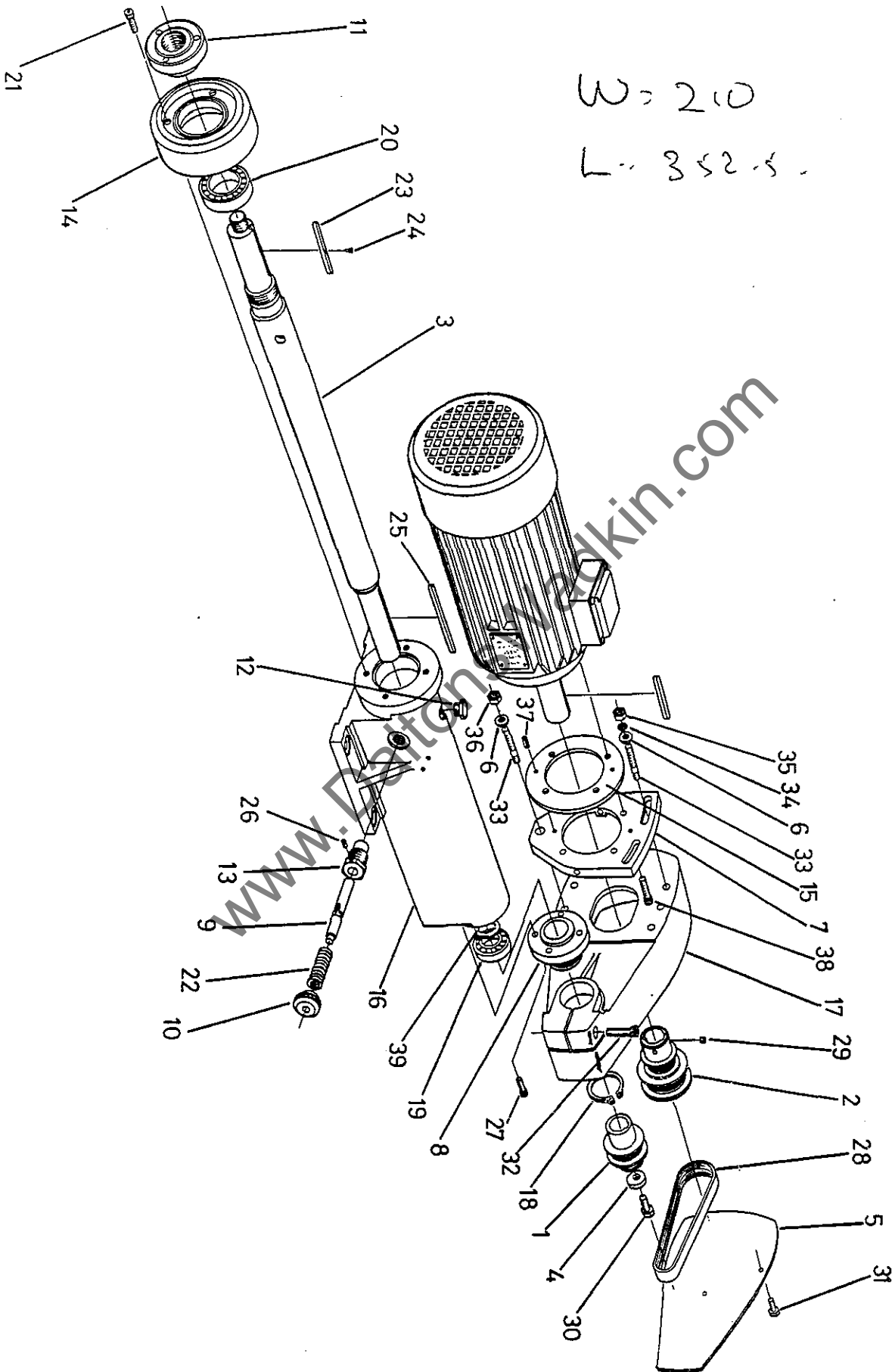

FIG 22 'B' TYPE HEAD

22 'B' TYPE HEAD

Ref	Description	No. Off
1	* Spindle Pulley	1
2	* Motor Pulley	1
3	* Spindle	1
4	Retaining Washer	1
5	Cover	1
6	Special Washer	3
7	Head Motor Adjustment Plate DP 258	1
8	Pivot Boss	1
9	Spindle Lock Plunger	1
10	Knob for Plunger	1
11	Spindle Locknut	1
12	Plug	2
13	Spindle Lock Body	1
14	Top Bearing Cap	1
15	Distance Plate	1
16	Spindle Housing WAA 374	1
17	Head Mounting Support Bracket DP 259	1
18	External Circlip dia 70mm	1
19	Ball Bearing 'SKF' 6207 - 2Z	1
20	Ball Bearing 'SKF' 6209 - Z	1
21	Hexagon Socket Capscrew M6 x 30mm long	4
22	Compression Spring 12.7mm O/D, 50.8mm long 1.25mm gauge	1
23	Key 10mm x 8mm x 65mm	1
24	Hexagon Socket Countersunk Screw M5 x 16mm long	1
25	Key 10mm x 8mm x 90mm	1
26	Hexagon Socket Grubscrew M4 x 8mm long	1
27	Hexagon Socket Capscrew M8 x 25mm long	4
28	'Poly V' Drive Belt 260 - J10	1
29	Hexagon Socket Grubscrew M10 x 10mm long	2
30	Hexagon Head Setscrew M12 x 30mm long	1
31	Hexagon Head Setscrew M8 x 30mm long	3
32	Hexagon Socket Capscrew M12 x 75mm long	1
33	Stud M10 x 60mm long	3
34	Spring Washer M10	2
35	Plain Nut M10	2

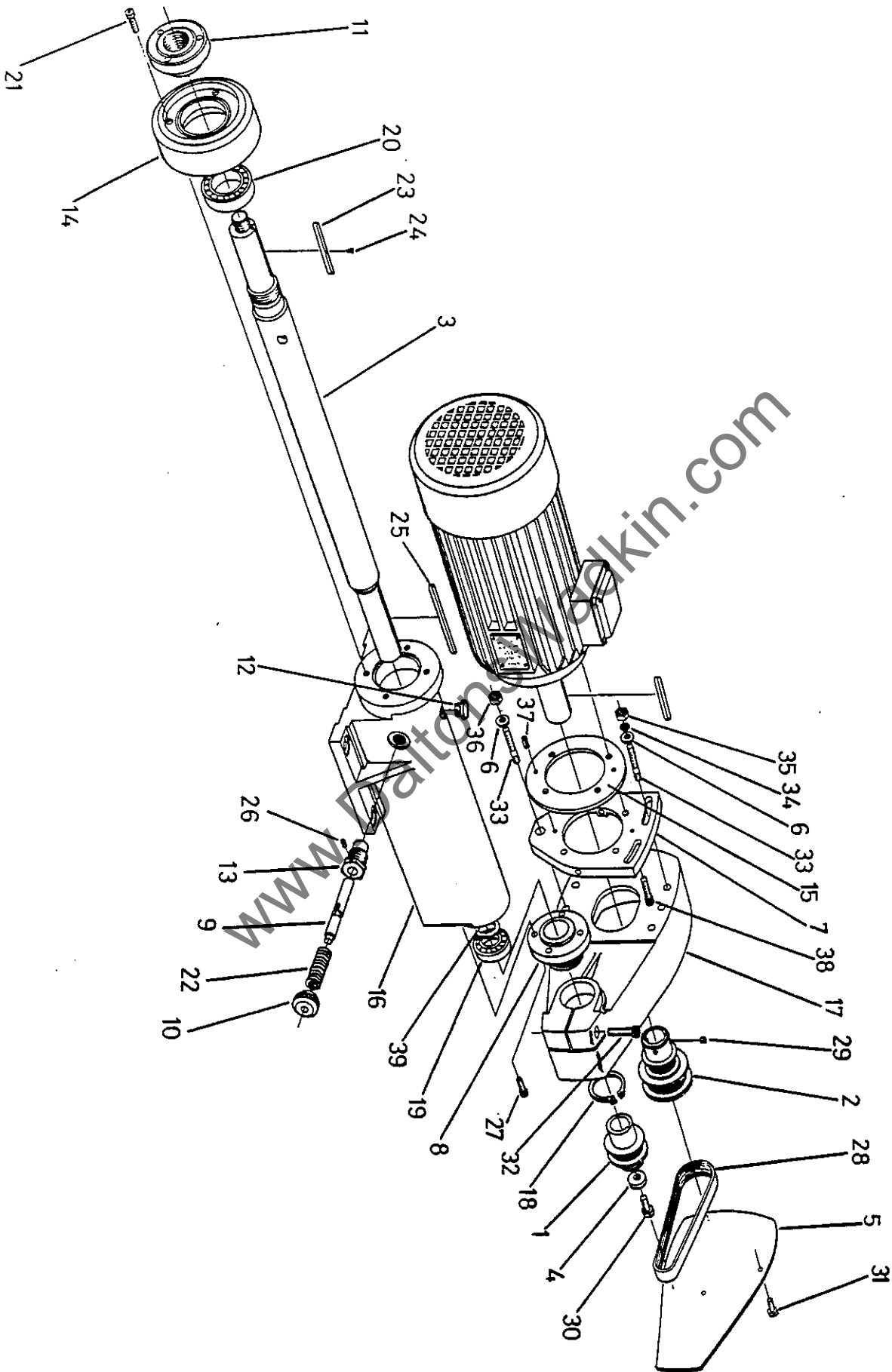

FIG 22 'B' TYPE HEAD



22 'B' TYPE HEAD - CONT.....

Ref	Description	No. Off
36	Self Locking Nut M10	1
37	Tension Pin dia 6mm	2
38	Hexagon Socket Capscrew M8 x 30mm long	4
39	Pre Load Wavey Washer	1

* Specify Spindle Speed and Diameter

www.DaltonsWadkin.com

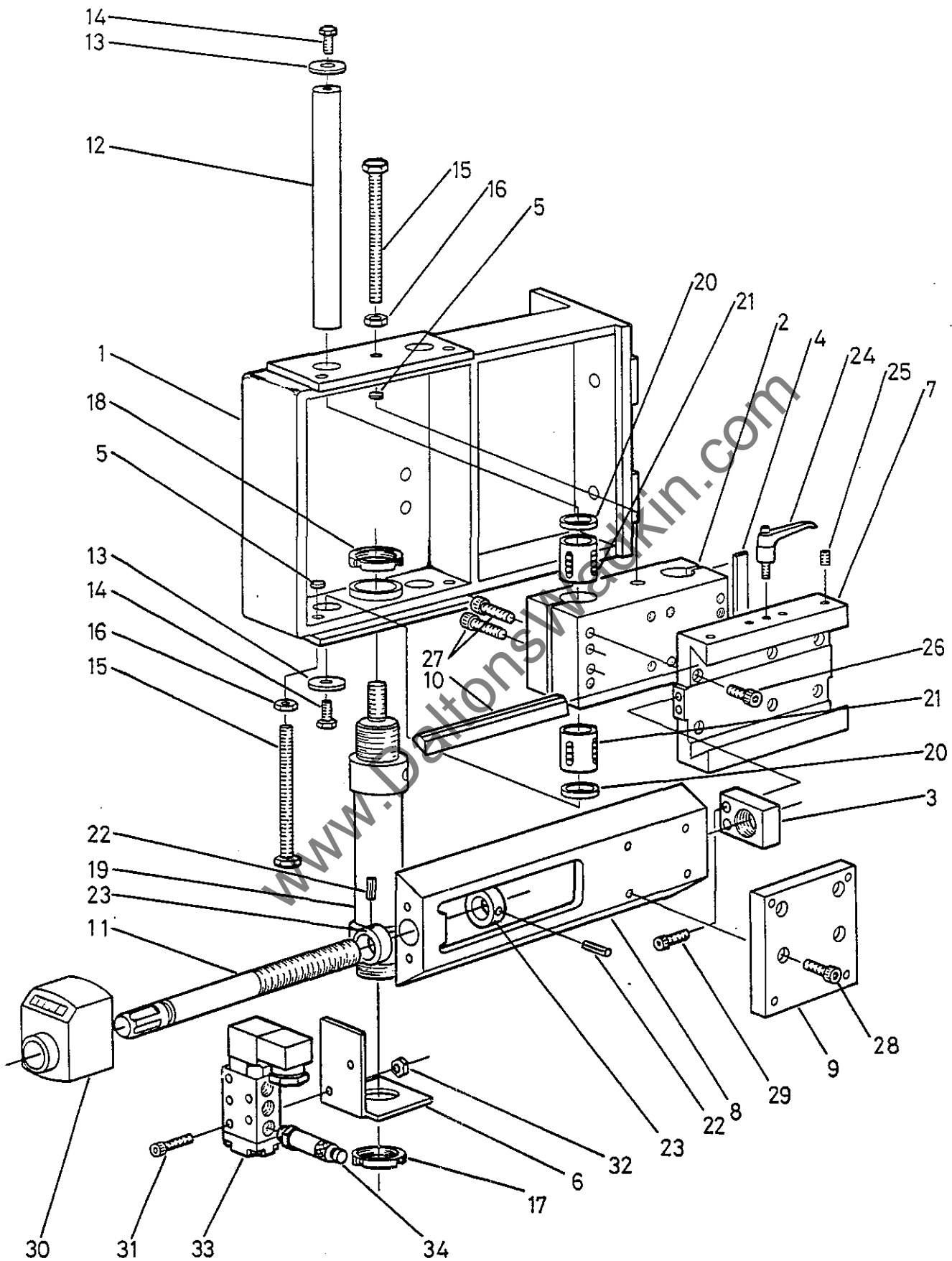

FIG 23 BEAM MOUNTED SCORER BODY

23 BEAM MOUNTED SCORER BODY

Ref	Description	No. Off
1	Scorer Bracket R.H. (Shown)	1
	or Scorer Bracket L.H.	1
2	Scorer Carriage	1
3	Nut for Leadscrew	1
4	Bearing Seal	2
5	Stop Pad	2
6	Mounting Pad for Solenoid Valve	1
7	Slide Base	1
8	Slide	1
9	Motor Mounting Plate for 0.55kW motor (shown)	1
	or Motor Mounting Plate for 1.1 kW motor	1
10	Gib Strip	1
11	Leadscrew	1
12	Precision Ground Shaft dia 25mm x 266mm long	2
13	Large Plain Washer M10	4
14	Hexagon Head Setscrew M10 x 20mm long	4
15	Hexagon Head Setscrew M12 x 130mm long	2
16	Locknut M12	2
17	Notch Nut M45 x 1.5mm	1
18	Notch Nut M45 x 1.5mm Supplied with Cylinder	
19	'Festo' Double Acting Cylinder DSW - 50 - 80p	1
20	'INA' Sealing Ring G25 x 35 x 4	4
21	'INA' Linear Ball Bearing KH 2540	4
22	Tension Pin dia 6mm x 32mm long	2
23	Plain Collar dia 32mm x 20mm bore	2
24	Bristol Type Locking Handle with Stud M10 x 25mm	1
25	Hexagon Socket Nyloc Grubscrew M10 x 20mm long	4
26	Hexagon Socket Capscrew M8 x 25mm long	6
27	Hexagon Socket Capscrew M8 x 30mm long	4
28	Hexagon Socket Capscrew M8 x 20mm long	4
29	Hexagon Socket Capscrew M8 x 16mm long	2
30	Siko Dial Indicator	1
31	Hexagon Socket Capscrew M4 x 35mm long	2
32	Plain Nut M4	2
33	'Schrader Bellows' 1/4 " BSP Solenoid Valve B53414SM	1 K3061982
34	'Maxam' Throttle Valve 705013720E	2 K3061694

SECTION 5

ILLUSTRATED PARTS LIST

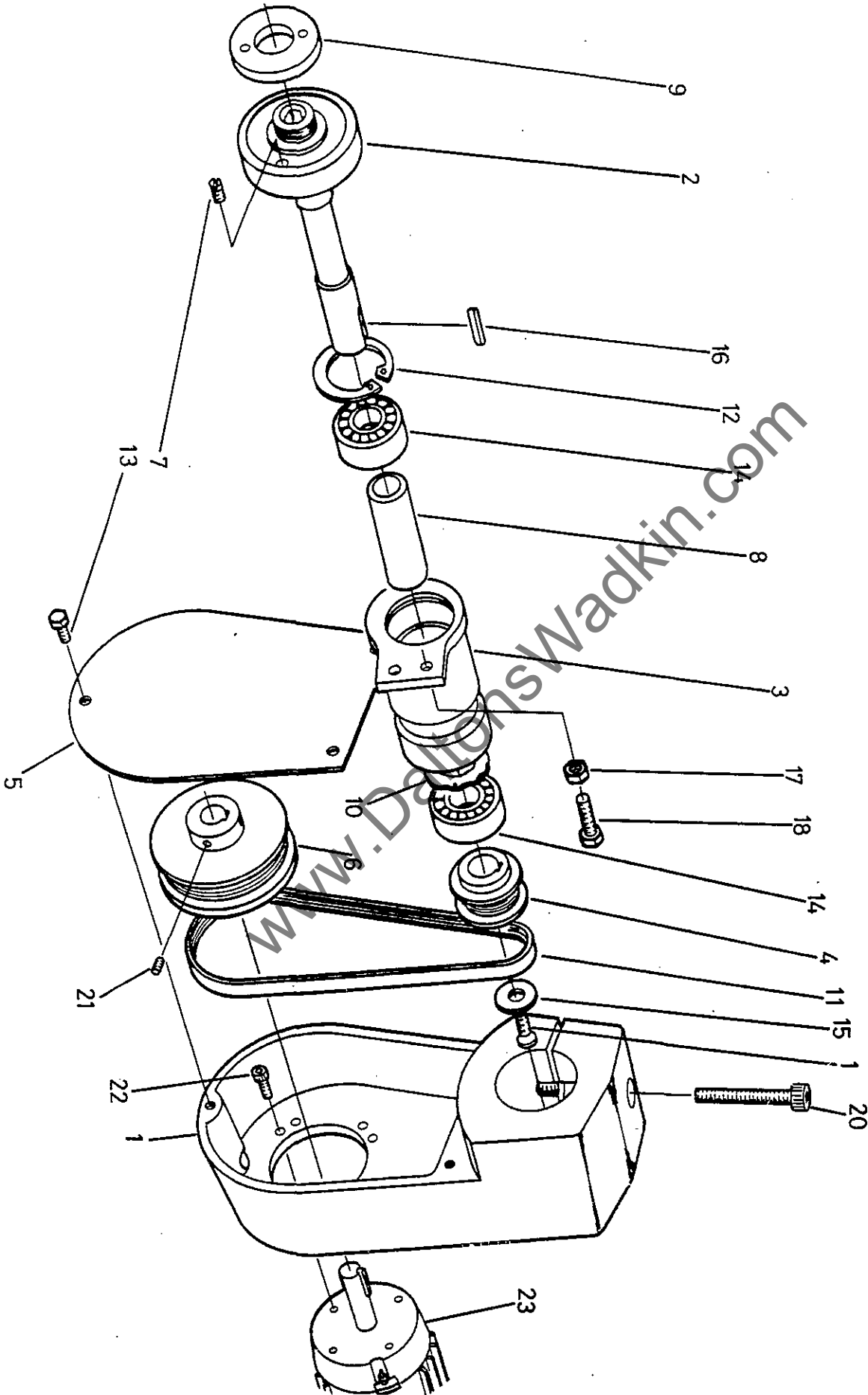

FIG 24 BELT DRIVEN SCORER HEAD

24 BELT DRIVEN SCORER HEAD

Ref	Description	No. off
1	Scorer Housing	1
2	Scorer Spindle	1
3	Rise and Fall Quill	1
4	Scorer Spindle Pulley	1
5	Cover	1
6	Scorer Motor Pulley	1
7	Peg for Scorer Saw	1
8	Bearing Spacer	1
9	Retaining Collar	1
10	Preload Wavey Washer	1
11	'Poly V' Drive Belt 180 - J4 <u>K 3078391</u>	1
12	Internal Circlip dia 35mm	1
13	Hexagon Head Setscrew M5 x 10mm long	3
14	'SKF' Ball Bearing 6003 - 2RS	2
15	Washer for Spindle Pulley	1
16	Key 5mm x 5mm x 15mm	1
17	Locknut M5	2
18	Hexagon Head Setscrew M5 x 25mm long	2
19	Hexagon Socket Countersunk Screw M8 x 20mm long	1
20	Hexagon Socket Capscrew M8 x 55mm long	1
21	Hexagon Socket Grubscrew M6 x 8mm long	2
22	Hexagon Socket Capscrew M6 x 20mm long	4
23	'Brook' Motor D71 BH 0.55kW, 3PH, 50HZ	1



SECTION 5

ILLUSTRATED PARTS LIST

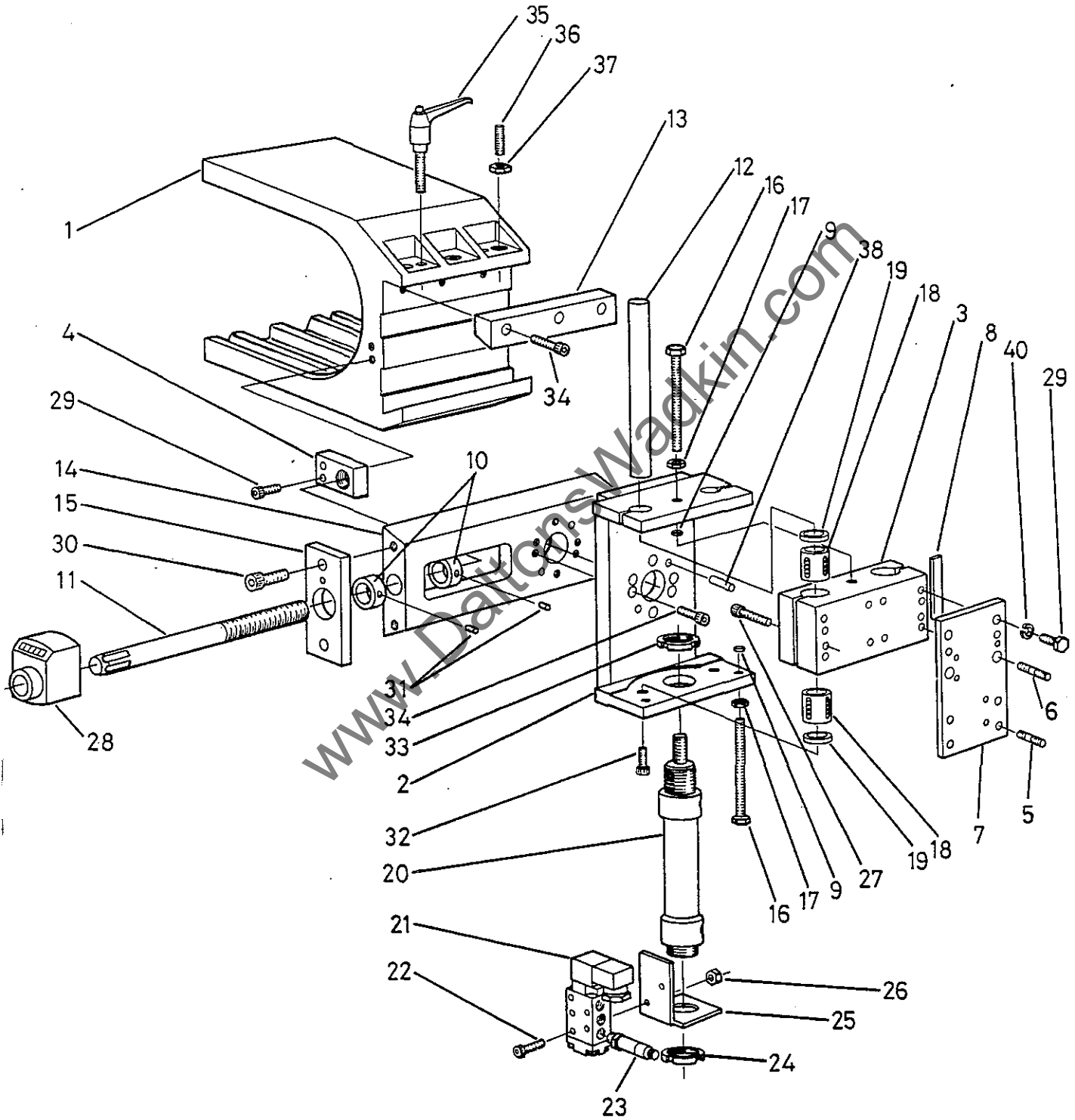

FIG 25 HEAD MOUNTED SCORER BODY

25 HEAD MOUNTED SCORER BODY

Ref	Description	No off
1	Jump scorer tie bracket	1
2	Scorer body	1
3	Scorer carriage	1
4	Nut for lead screw	1
5	Stud for motor carriage	2
6	Stud for motor plate	2
7	Scorer motor plate	1
8	Bearing seal for scorer	2
9	Stop pad	2
10	Collar	2
11	Lateral adjusting screw	1
12	Scorer slide bars	2
13	Gib	1
14	Cross slide	1
15	Scorer adjusting tie plate	1
16	Hexagon head setscrew M12 x 130mm long	2
17	Lock nut M12	2
18	'INA' linear ball bearing KH2540	4K0607143
19	'INA' sealing ring G25 x 35 x 4	4K3074358
20	'Festo' double acting cylinder DSW - 50 - 80p	1
21	'Schrader bellows' 1/4" BSP solenoid valve B53414SM	1
22	Hexagon socket capscrew M4 x 35mm long	2
23	'Maxam' throttle valve 705013720E	2
24	Notch nut M45 x 1.5mm pitch	1
25	Mounting pad for solenoid valve	1
26	Plain nut M4	2
27	Hexagon socket capscrew M8 x 30mm long	4
28	'Siko' dial indicator	1
29	Hexagon socket capscrew M8 x 16mm long	2
30	Hexagon socket capscrew M8 x 25mm long	2
31	Tension pin dia 6mm x 32mm long	2
32	Hexagon socket capscrew M10 x 25mm long	2
33	Notch nut M45 x 1.5mm pitch (supplied with cylinder)	1
34	Hexagon socket capscrew M8 x 30mm long	9
35	Bristol locking handle M10	2
36	Hexagon socket grubscrew M8 x 25mm long	3
37	Locknut M8	3

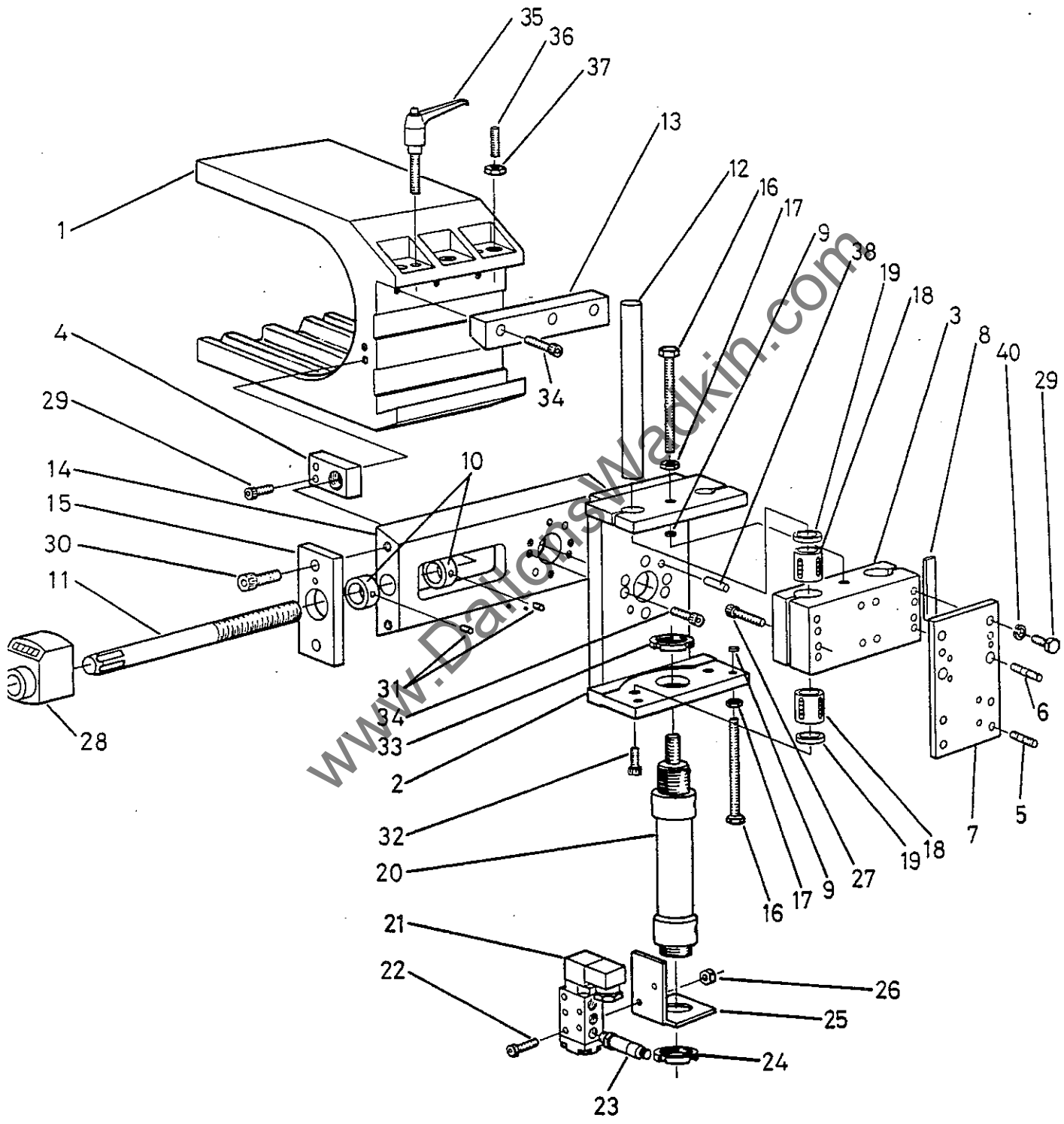

FIG 25 HEAD MOUNTED SCORER BODY



25 HEAD MOUNTED SCORER BODY CONT.....

Ref	Description	No off
38	Dowel diameter 8mm x 35mm long	2
39	Hexagon head setscrew M8 x 25mm long	2
40	Spring washer M8	2

www.DaltonsWadkin.com

SECTION 5

ILLUSTRATED PARTS LIST

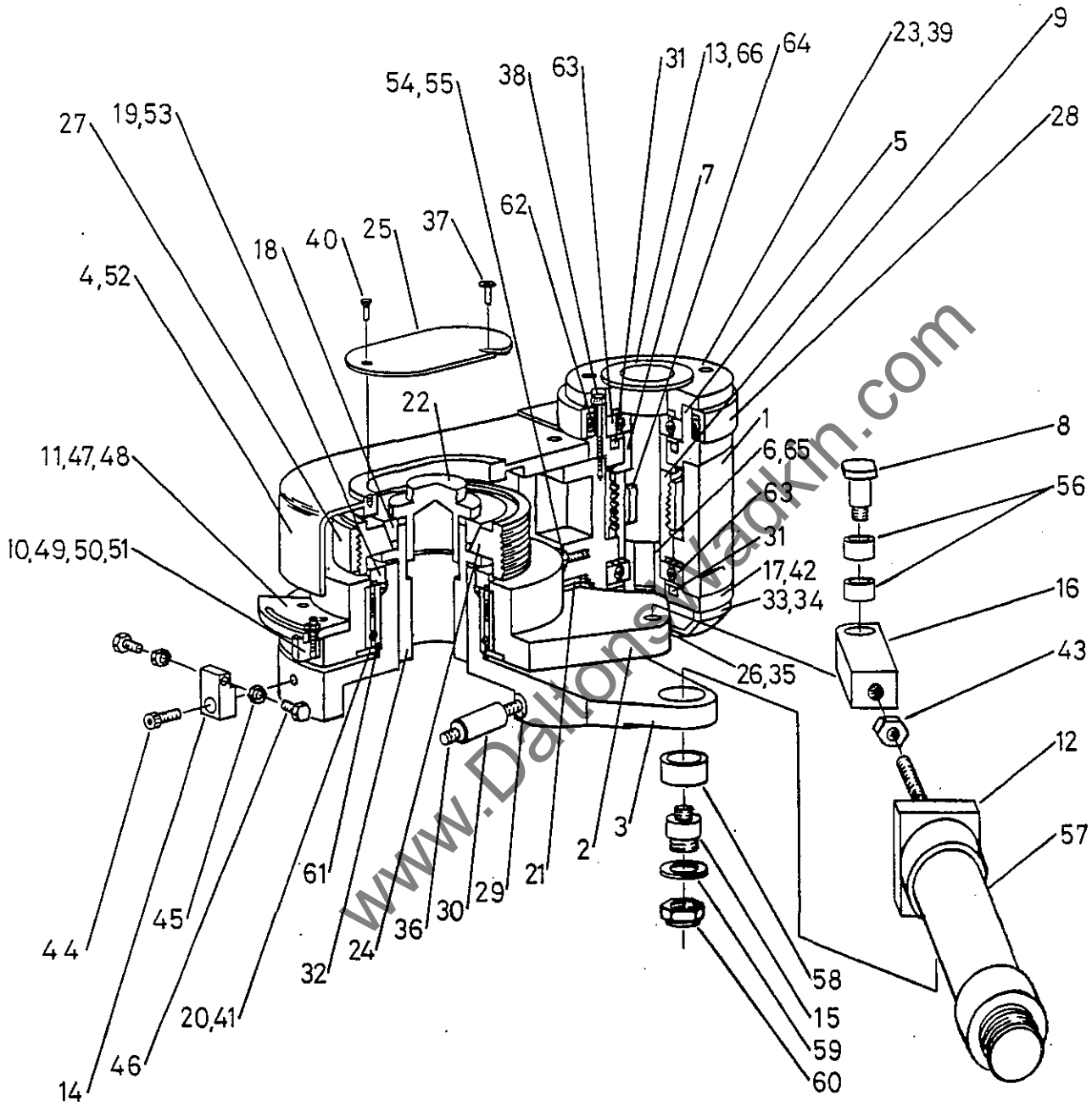

FIG 26 RELISHING HEAD

26 RELISHING HEAD

Ref	Description	No off
1	Spindle body	1
2	Arm for head	1
3	Base plate for head	1
4	Guard for drive	1
5	Top bearing housing	1
6	Sleeve for bottom bearing	1
7	Spacer for top bearing	1
8	Pirot pin for connecting link	1
9	Driven pulley	1
10	Stop	2
11	Quaderant plate	1
12	Cylinder adaptor	1
13	Relish spindle	1
14	Base plate stop	1
15	Pirot pin	1
16	Connecting link	1
17	Bottom bearing end cap	1
18	Cone for driving pulley	1
19	Locknut for bearing	1
20	Clamp ring for bearing	1
21	Key	1
22	Nut for motor	1
23	End cap, top bearing	1
24	Driving pulley	1
25	Cover for drive guard	1
26	Cover	1
27	'Poly - V' belt - 220j13	1
28	Cam follower	1
29	Plain locking pad	1
30	Threaded locking pad	1
31	Felt ring	2
32	Spindle sleeve (specify spindle diameter).	1
33	Cover	1
34	Hexagon socket capscrew $\frac{3}{16}$ BSW x 1 $\frac{1}{4}$ long	3
35	Round head screw $\frac{3}{16}$ BSW x $\frac{3}{8}$ long	1
36	Hexagon socket capscrew M10 x 120mm long	1
37	Round head screw $\frac{1}{4}$ BSW x $\frac{1}{2}$ long	1

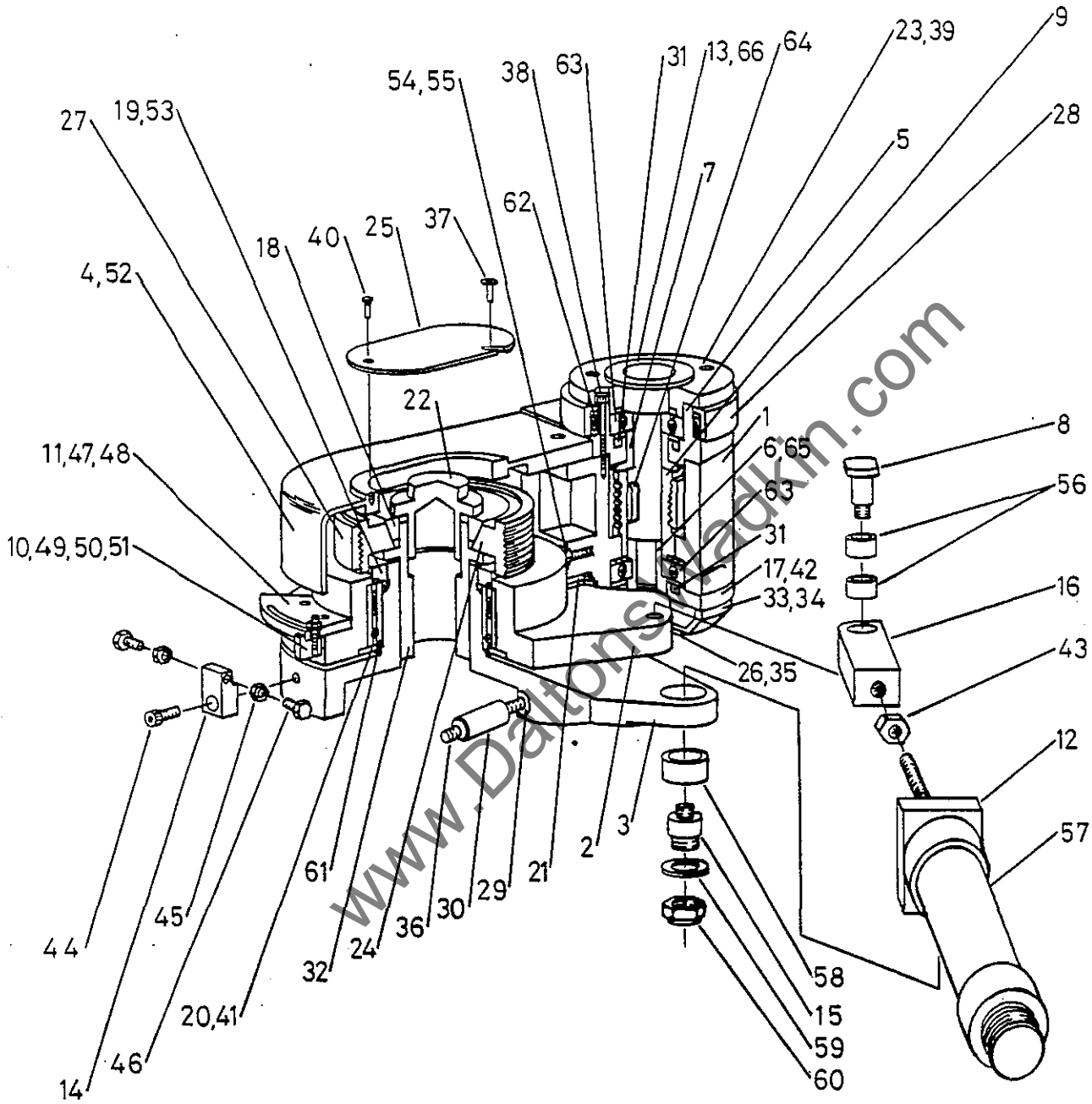

FIG 26 RELISHING HEAD

26 RELISHING HEAD CONT.....

Ref	Description	No off
38	Hexagon socket capscrew M5 x 50mm long	3
39	Hexagon socket capscrew $\frac{3}{16}$ BSW x $\frac{1}{2}$ long	3
40	Counter sunk hexagon socket screw $\frac{1}{4}$ BSW x $\frac{1}{2}$ long	1
41	Counter sunk hexagon socket screw $\frac{3}{16}$ BSW x $\frac{1}{2}$ long	3
42	Hexagon socket capscrew M5 x 25mm long	4
43	Locking nut M16 x 2P	1
44	Hexagon socket capscrew $\frac{5}{16}$ BSW x $\frac{5}{8}$ long	2
45	Locking nut $\frac{1}{4}$ BSW	2
46	Hexagon head setscrew $\frac{1}{4}$ BSW x $\frac{1}{2}$ long	2
47	Hexagon socket capscrew $\frac{5}{16}$ BSW x $\frac{3}{4}$ long	2
48	Dowel $\frac{5}{16}$ dia x 1" long	2
49	Stud $\frac{3}{8}$ BSW x 1 $\frac{1}{2}$ long	2
50	Nut $\frac{3}{8}$ BSW	2
51	Plain washer $\frac{3}{8}$ BSW	2
52	Hexagon socket capscrew M6 x 12mm long	2
53	Counter sunk hexagon socket screw $\frac{3}{16}$ BSW x 1 $\frac{1}{2}$ long	1
54	Hexagon head setscrew M6 x 40mm long	1
55	Locking nut M6	1
56	'Compo' bush SN 066 x .625"	2
57	'Festo' DSW - 50 - 80p cylinder	1
58	Bush 25mm O/D x 20mm I/D x 25mm long	1
59	Plain washer M16	1
60	Self locking nut M16	1
61	'INA' needle roller / angular contact ball bearing NK16 - 5914	1
62	'INA' needle roller bearing K80 x 86 x 20	1
63	'RHP' ball bearing IP / 6206	2
64	Key $\frac{3}{16}$ square x 1 $\frac{1}{2}$ long	1
65	Key $\frac{3}{16}$ sq x $\frac{1}{2}$ long	1
66	Locknut for spindle	1



ILLUSTRATED PARTS LIST

SECTION 5

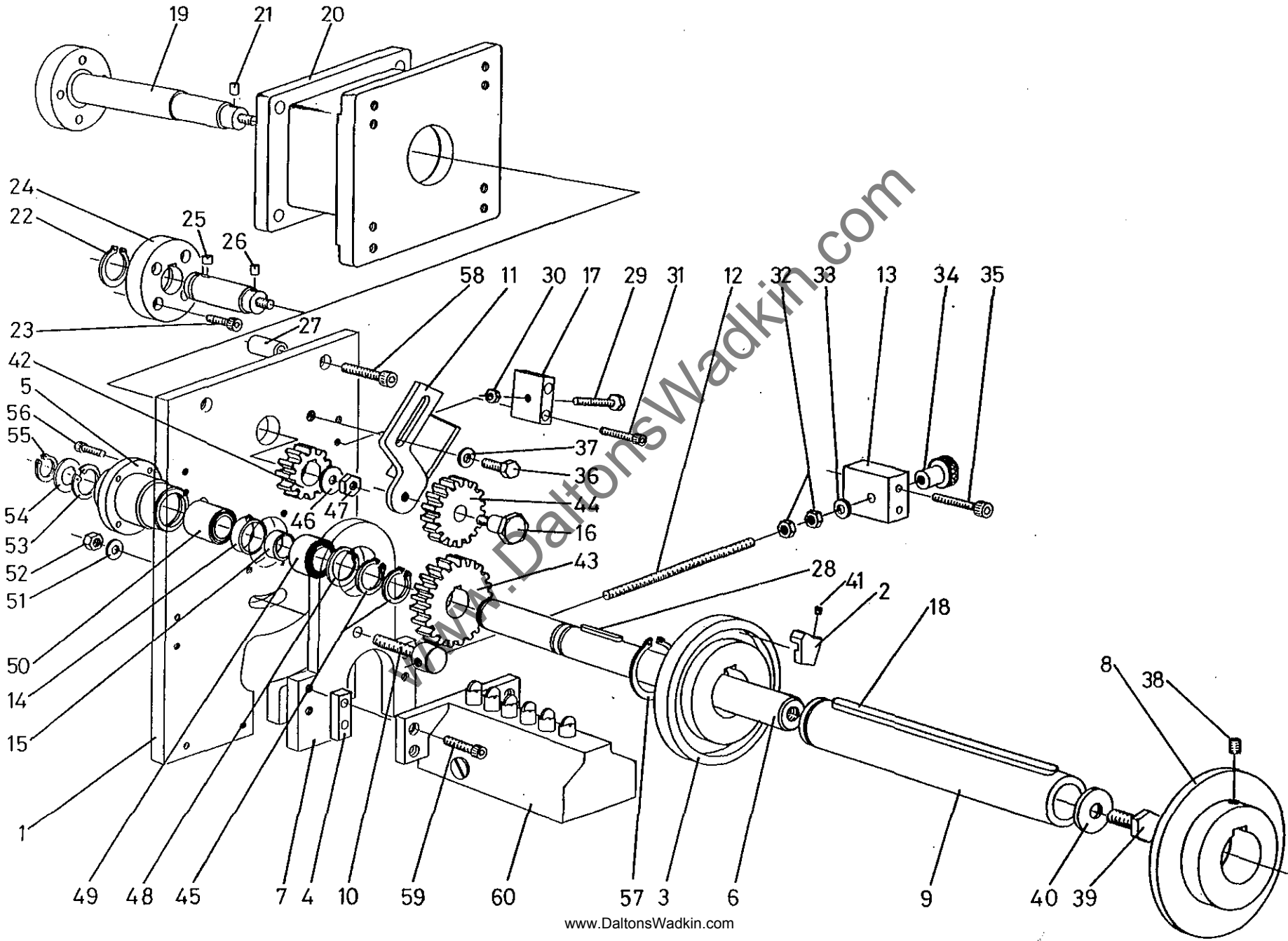

FIG 27 TIMING DRUM

27 TIMING DRUM

Ref	Description	No off
1	Timing drum backplate	1
2	Trip dog	2 per cam disc
3	Cam disc	as required
4	Packing block	2
5	Cam shaft housing	1
6	Cam shaft	1
7	Pivot plate	1
8	Cam disc clamp	1
9	Cam shaft sleeve	1
10	Clamp screw	1
11	Intermediate gear arm	1
12	Leadscrew	1
13	Leadscrew housing	1
14	Bearing spacer (outer)	1
15	Bearing spacer (inner)	1
16	Pivot pin	1
17	Jacking plate	1
18	Key 12mm x 8mm x 155mm long	1
19	Drive shaft	1
20	Support for timing drum	1
21	Plain dowel dia 6mm x 12mm long	1
22	'INA' external circlip WR25	1
23	Hexagon socket capscrew M8 x 20mm long	4
24	Drive adaptor plate	1
25	Plain dowel dia 8mm x 16mm long	1
26	Plain dowel dia 6mm x 12mm long	1
27	Spacer	4
28	Key 6mm x 6mm x 40mm long	1
29	Hexagon head setscrew M6 x 35mm long	1
30	Nut M6	1
31	Hexagon socket capscrew M6 x 45mm long	2
32	Lock nut M8	2
33	Large plain washer M8	1
34	Thumb nut 'WDS' 520-204	1
35	Hexagon socket capscrew M6 x 45mm long	2
36	Hexagon head setscrew M10 x 20mm long	1
37	Large plain washer M10	1



ILLUSTRATED PARTS LIST

SECTION 5

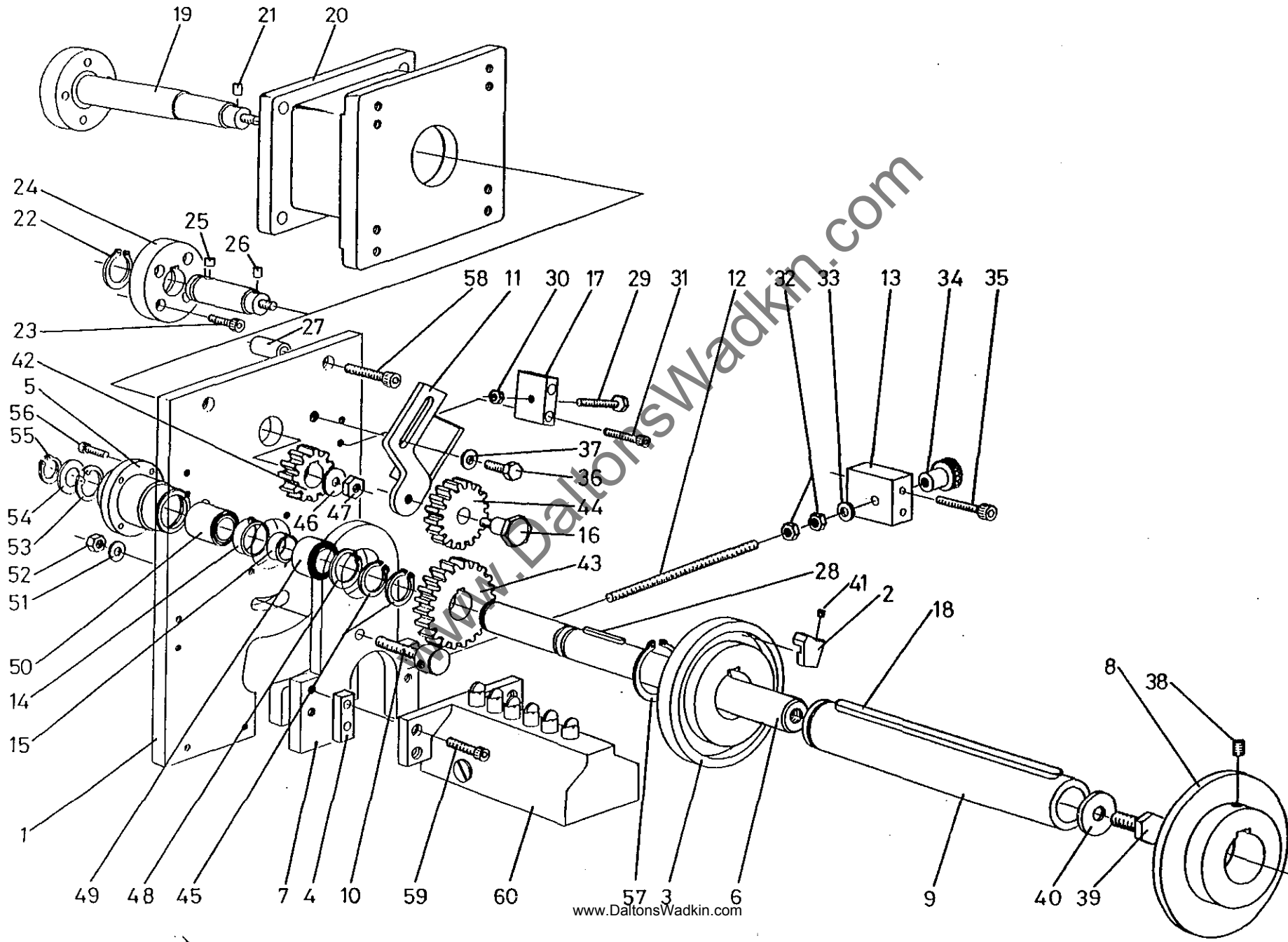

FIG 27 TIMING DRUM

27 TIMING DRUM CONT....

Ref	Description	No off
38	Hexagon socket grubscrew M6 x 20mm long	1
39	Hexagon head setscrew M10 x 20mm long	1
40	Large plain washer M10	1
41	Hexagon socket grubscrew M5 x 6mm long	1 per trip dog
42	'HPC' tufnol gear to suit required speed	1
43	'HPC' tufnol gear to suit required speed	1
44	'HPC' tufnol gear	1
45	External circlip dia 20mm	2
46	Large plain washer M10	1
47	Nut M10	1
48	Internal circlip dia 37mm	1
49	'INA' needle roller bearing NA 4904RS	1
50	'INA' needle roller / angular contact bearing NKIB 5904	1 KO614223
51	Large plain wahser M12	1
52	Nut M12	1
53	Internal circlip dia 37mm	1
54	Plain washer M20	1
55	External circlip dia 20mm	1
56	Hexagon socket capscrew M6 x 20mm long	4
57	External circlip dia 40mm	1
58	Hexagon socket capscrew M8 x 50mm long	4
59	Hexagon socket capscrew M6 x 30mm long	4
60	'Euchner' 12 way limit switch GSBF 12R12 - 502	1
or	'Euchner' 6 way limit switch RGBF 06R12 - 502	1