



S400

**HIGH PRECISION
SURFACE PLANERS**

INSTRUCTION MANUAL No. 3014

PREFACE

IMPORTANT

IT IS OUR POLICY AND THAT OF OUR SUPPLIERS TO CONSTANTLY REVIEW THE DESIGN AND CAPACITY OF OUR PRODUCTS. WITH THIS IN MIND WE WOULD REMIND OUR CUSTOMERS THAT WHILE THE DIMENSIONS AND PERFORMANCE DATA CONTAINED HEREIN ARE CURRENT AT THE TIME OF GOING TO PRESS, IT IS POSSIBLE THAT DUE TO THE INCORPORATION OF THE LATEST DEVELOPMENTS TO ENHANCE PERFORMANCE, DIMENSIONS AND SUPPLIERS MAY VARY FROM THOSE ILLUSTRATED

THIS MANUAL IS WRITTEN AS A GENERAL GUIDE. A TYPICAL MACHINE IS SHOWN TO ILLUSTRATE THE MAIN FEATURES.

Failure to comply with instructions in this book may invalidate the guarantee

HEALTH & SAFETY

SAFETY OF WOODWORKING MACHINES.

Woodworking machines can be dangerous if improperly used. The wide range of work of which they are capable, requires adequate safeguarding arrangements against possible hazards.

Many injuries to machinists are caused by carelessness or failure to use the guards provided or to adjust them correctly.

Wadkin plc supply machinery designed for maximum safety which they believe, as a result of thorough testing, minimizes the risks inevitable in their use. It is the users responsibility to see that the following rules are complied with to ensure safety at work:

- 1) The operation of the machine should conform to the requirements of the UK Woodworking Machines Regulations 1974. All guards should be used and adjusted correctly.
- 2) Safe methods of working only should be adopted as given in BS.6854 Part 1, "Safeguarding Woodworking Machines" (UK only) and subsequent parts for specific machines (obtainable from Her Majesty's Stationery Office) and as advised by Wadkin plc.
- 3) Only personnel trained in the safe use of a machine should operate it.
- 4) Before making adjustments or clearing chips, etc., electrically isolate machine and ensure all movements have ceased.
- 5) All tools and cutters must be securely fixed and the correct speed selected.

Safety is our watchword, but the user must comply with the above rules in his own interest. We would be pleased to advise on the safe use of our products.

Wadkin Leicester
Green Lane Works
Leicester. LE5 4PF
England
Telephone: 0533 769111
Telex: 34646 Wadkin G
Fax: 0533 742310

SAFETY INSTRUCTIONS

Carefully read instruction manual with particular reference to the following instructions:-

- a) Slings, ie, safe lifting limits for slings, etc.
- b) Installation and foundation, ie, safe working area of machine, bolt positions, etc.
- c) Wiring details, ie, connection of machine to mains supply, fuse details, etc.
- d) Machine controls and operating instructions.

Ensure tooling is of the correct type for use with the machine and cutters are securely fixed in position.

Select correct spindle speed and feed rate relevant to the tooling being used.

Set all guards correctly and ensure they are securely fixed in accordance with the current regulations.

Use suitable jigs, fixtures and feeding devices etc., (push stick, etc.,) where appropriate.

Refer to BS.6854, Part 1, "Safeguarding Woodworking Machines" UK market and subsequent parts for specific machines for safe working practices.

During Machining

Wear suitable protective equipment, where necessary, eg, goggles, ear defenders and dust mask.

Ensure all moving parts of the machine are stationary before setting, cleaning or making any adjustments.

Report immediately to a person in authority any machine malfunction or operator hazard. Do not attempt to repair the machine unless authorised to do so.

Ensure machine is electrically isolated before any maintenance/cleaning work commences.

NOISE LEVELS

This machine, under certain conditions, will emit noise levels in excess of 85dB(a).

Noise levels will be affected by the environment in which the machine operates the timber being machined, tooling, machine setting and dust extraction.

Further information available from Wadkin on request.

As a manufacturer it is Wadkin's policy to reduce the noise level as far as it is practicable.

Specification**S400**

Table width	400mm	(15 ³ / ₄ in)
Length of infeed table	1440mm	(57in)
Length of outfeed table	1138mm	(45in)
Overall length of machine	2600mm	(102in)
Table height from floor	800mm	(31 ¹ / ₂ in)
Length of fence	1100mm	(43in)
Height of fence	175mm	(6 ⁷ / ₈ in)
Fence cants	45°	
Overall height of machine	975mm	(38in)
Cutterblock speed	4200	rev/min
Cutting circle diameter	120mm	(4 ³ / ₄ in)
Maximum depth of rebate	20mm	(³ / ₄ in)
Motor	3kW	(4hp)
Net weight	635kg	(1400lb)
Gross weight	700kg	(1543lb)
Shipping dimensions	2.15m ³	(76cu.ft)

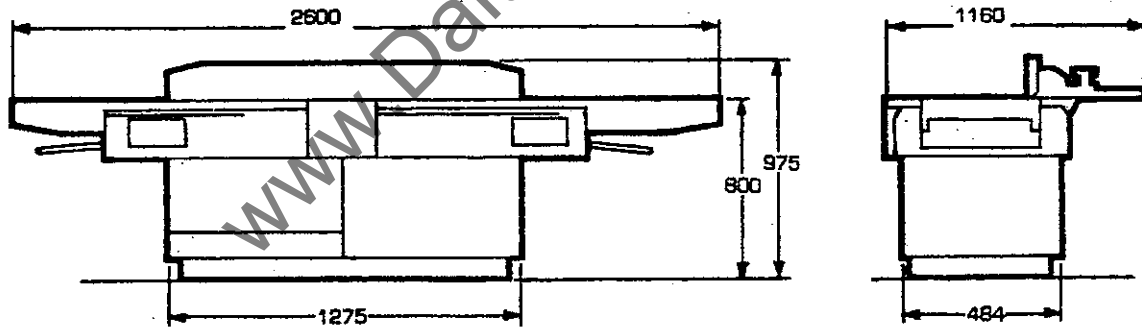

VOLTAGE	PHASE	KW	SWG TINNED COPPER WIRE	AMPS	DIRECT ON LINE
220	3	4	14	90	
380	3	4	17	52	
415	3	4	17	47	

380	3	4	22	25	STAR/DELTA
415	3	4	23	20	

USA/CANADA			CARTRIDGE FUUSE AMPS
VOLTAGE	PHASE	HP	
220/230	3	6.6	105
440	3	6.6	52
575	3	6.5	34

www.DaltonsWadkin.com

LIFTING

THE MACHINE IS NORMALLY SUPPLIED COVERED IN PLASTIC SHEET WITH SUNDRY ITEMS PACKED IN BOXES AND STRAPPED TO THE MACHINE FRAME. BEFORE LIFTING TO WORK POSITION REMOVE SHEETING AND ALL BOXES ALONG WITH ANY LOOSE ITEMS.

THE MACHINE AS RECEIVED IN THIS FORM WILL WEIGH APPROXIMATELY 1000 kg AND SHOULD THEREFORE BE RAISED WITH STRONG ROPES OR SLINGS WHICH ARE KNOWN TO BE IN SOUND CONDITION. THE SLINGS SHOULD BE PLACED TO GIVE A WIDE SPREAD AND SHOULD BE PROTECTED BY PADDING AT THEIR POINT OF CONTACT WITH THE MACHINE. (ie)

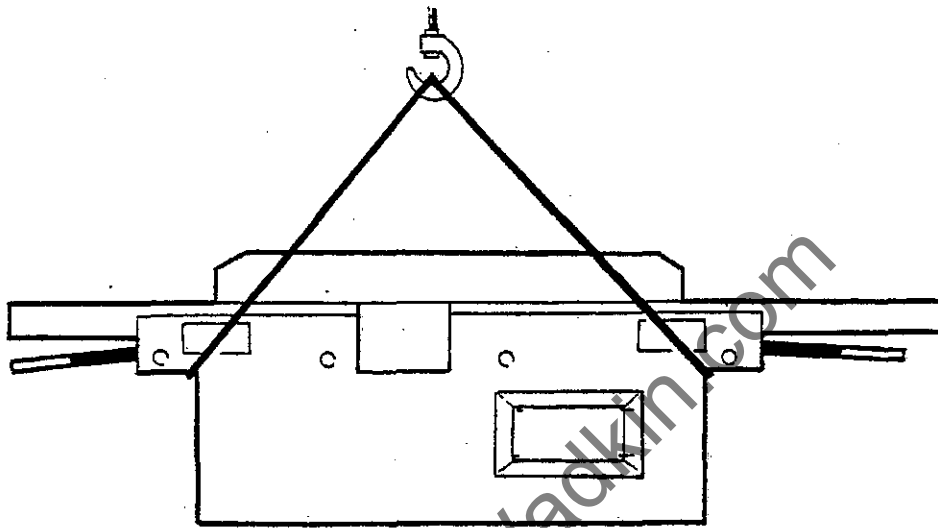

- 1) WHEN LIFTING WITH ROPE TYPE SLINGS PROTECT AROUND CORNERS OR SHARP EDGES WITH OLD SACKING.
- 2) WHEN USING POWER HOISTS LIFT SLOWLY FROM GROUND LEVEL TO ASCERTAIN STABILITY OF LIFT. A LOAD SHOULD BE RAISED IN THE AIR TO BE SUSPENDED AS LEVEL AS POSSIBLE. IF ON LIFTING THE LOAD SHOWS SIGNS OF TILTING LOWER OFF AND READJUST SLINGS.
- 3) NEVER RAISE A LOAD WITH LOOSE ITEMS UPON IT.
- 4) WHEN MOVING MACHINE OR CRATE TO FOUNDATION POINT VIA OVERHEAD BLOCK OR HOIST, BEFORE MOVING OFF LOWER LOAD DOWN TO WITHIN A COUPLE OF INCHES OFF GROUND LEVEL.
- 5) WHERE LIFTING HOOKS EYE BOLTS OR SPECIAL GRABS ARE PROVIDED ENSURE SUCH FITMENTS ARE SECURED TO THE LOAD BEFORE LIFTING.
- 6) BEFORE USING ANY ROPE, BELT SLING OR CHAINS ENSURE IT IS IN SOUND CONDITION. CUT OR FRAYED ROPES, BELTS OR CHAINS WITH SPRAINED OR SUSPECT LINKS SHOULD NEVER BE USED.
- 7) WHEN OFF-LOADING MACHINE OR CRATE, STAND WELL CLEAR.
- 8) KEEP LOAD STATIONARY WHEN SUSPENDED, DO NOT ALLOW LOAD TO SWING.
- 9) BEFORE LIFTING CHECK MACHINE OR CRATE FOR ANY SPECIAL LIFTING INSTRUCTIONS.
- 10) IF A CRATE IS DAMAGED TO THE POINT WHERE IT IS INSECURE, UNPACK AND LIFT MACHINE ONLY.

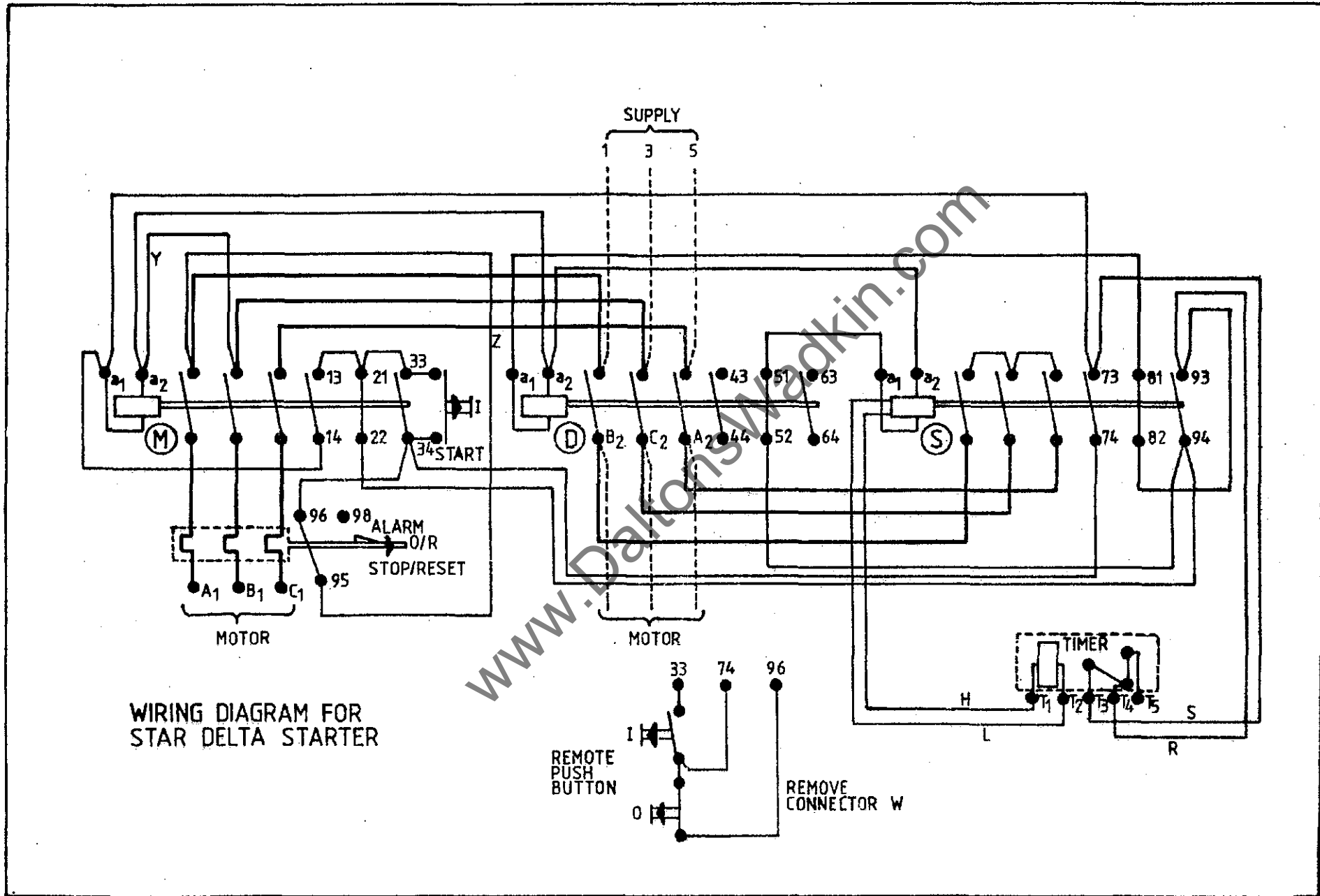

WIRING DIAGRAM FOR STAR DELTA STARTER

Installation.-

www.DaltonsWadkin.com

Remove protective anti-rust coating from bright parts by applying a cloth soaked in paraffin or other solvent.

Wiring:-

The motor and control gear have been wired in before despatch, therefore all that is required to be done is to connect the mains supply to the starter, or isolator where fitted.

POINTS TO NOTE WHEN CONNECTING TO POWER SUPPLY:-

- 1 - Check voltage, phase and frequency.
- 2 - It is important that the correct cable is used to deliver the correct voltage to the starter. RUNNING ON LOW VOLTAGE WILL DAMAGE MOTOR.
- 3 - Check main line fuses are of correct capacity.
- 4 - Connect line leads to correct terminals (SEE WIRING DIAGRAM).
- 5 - Check all connections are sound.
- 6 - Check spindle rotates in correct direction. If not reverse any two of the line lead connections.

FAILURE TO START:-

- 1 - Fuses have blown or have not been fitted.
- 2 - Isolator switch has not been closed.
- 3 - Lock off or stop button (when fitted) has not been released.
- 4 - Supply not available at machine.

STOPPAGE DURING OPERATION & FAILURE TO RESTART:-

- 1 - Overloads have tripped. If hand re-set, set by pressing button. If automatic they will re-set after a short period.
- 2 - Fuses have blown.

FOUNDATION:-

TABLE ADJUSTMENT (FIG.4)

(INFEED TABLE)

To adjust the infeed table unlock handwheel A and operate hand lever B to bring table into required position. After adjusting re-lock handwheel A.

(OUTFEED TABLE)

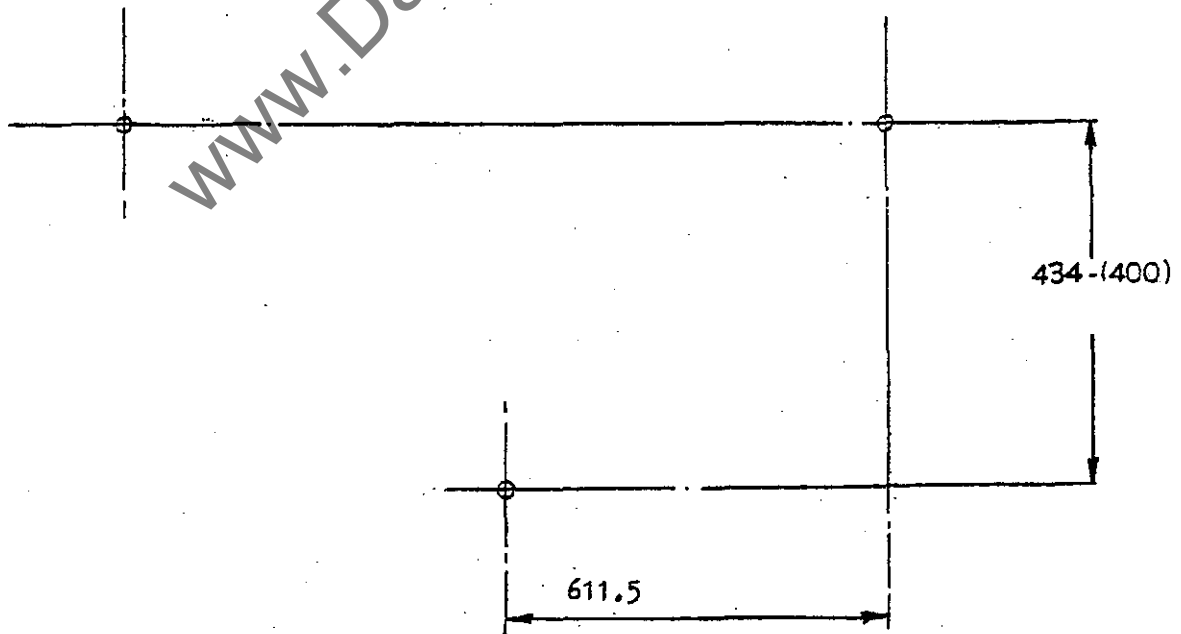
The outfeed table is provided with similar adjustment as outlined above, but under normal conditions will remain set level with the cutterblock knives.

DEPTH INDICATOR (FIG.5)

It is recommended that the table depth indicator setting is checked periodically to ensure constant accuracy of work. The procedure is simple and should be undertaken as follows.

- 1 :- Bring the outfeed table into the top position and lock in place.
- 2 :- Useing a straight edge off the rear table, check at three or four points along the length of the blade to ensure that the table is level with the cutting circle (FIG.5A).
- 3 :- Raise the infeed table into the top position and check with straight edge to ensure that both infeed and outfeed tables are parallel and level with the cutting circle (FIG.5B).
- 4 :- The reading against the datum line on the indicator (with table set in this position) should be ZERO. However, if adjustment is required simply rotate the setting screw in either direction to set the zero mark against datum line (FIG.5), re-lock lock nut after adjusting.

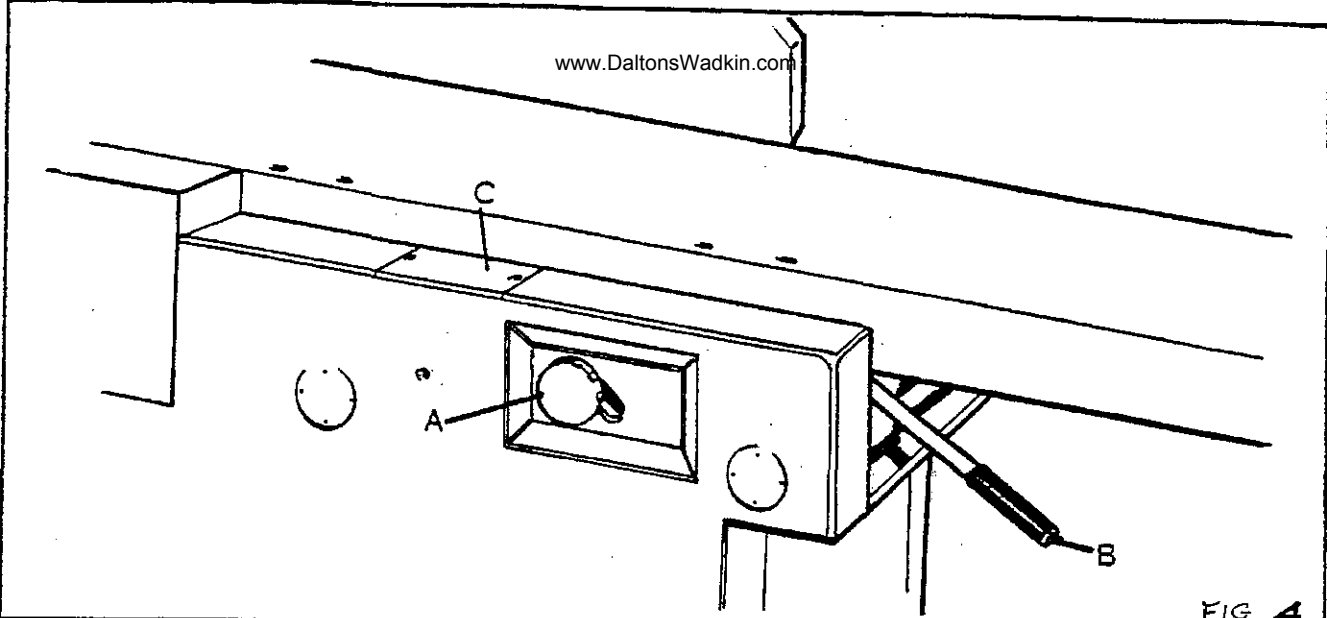

FIG. 4.

Straightedge

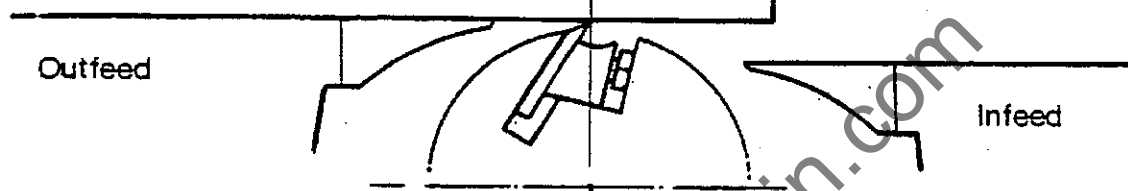

FIG 5A

Straightedge



FIG 5B

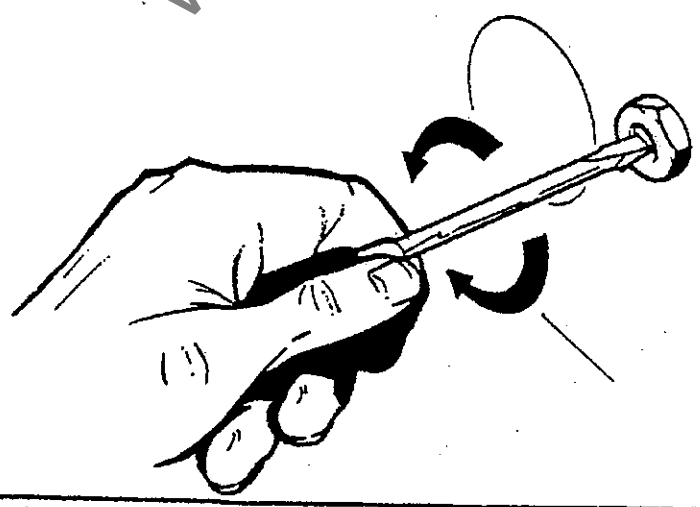
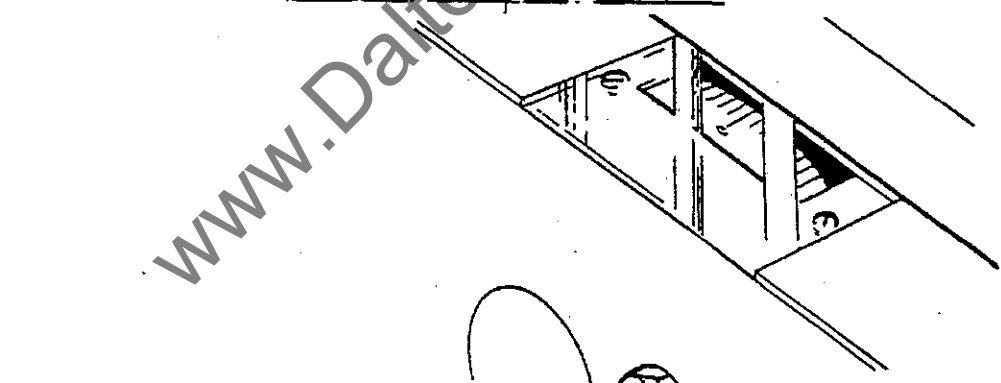

FIG 5.

CUTTER SETTING

The knife is held in the cutterblock by a wedge, into which is fitted spring loaded balls, these balls hold the knife finger tight whilst the M12 hexagon head screws are loose. This allows both hands to be free to adjust the blade and ensure that it will not slip back during setting or move whilst the wedge screws are being tightened up. Should any other method of cutter setting be employed the amount of cutter projection must correspond exactly with that given by the setting gauge supplied and failure to observe this instruction will result in bad feeding and poor finish.

To remove the knives and re-set with the 'BURSGREEN' knife setting gauge, proceed as follows:-

- 1) Turn the cutterblock to approximately the position shown in FIG. 6 and loosen the M12 hexagon head screws, carefully remove knife from cutterblock.

NOTE: When grinding it is most important that knives are ground dead straight and balanced in pairs or sets.

- 2) To re-set the knives the cutterblock should be in the approximate position shown in FIG. 6. Place the knife in between wedge and cutterblock with the blade drawn forward slightly.
- 3) Carefully secure the knife setting device 'C' FIG. 6 (which when not in use is secured to the left side base top cover) to the cutterblock with the two knurled locking screws 'D' as shown in FIG. 6.
- 4) Whilst turning these locking screws 'D' FIG. 6, knife will be lowered to correct setting which is reached when knurled screws are locked in position and knife just touches knife setting device.
- 5) When the knife is correctly set, tighten the M12 hexagon head screws, remove knife setting device then securely lock the M12 hexagon head screws.
- 6) Rotate cutterblock until the next knife is in position and repeat the procedure until all the knives have been set.
- 7) When changing knives it is advisable to check that all the locking screws are adequately lubricated and quite free. Periodically examine for damage or cracks. Any doubtful screws should be replaced and all screws well lubricated with 'Molyslip' or similar oil, before replacing.

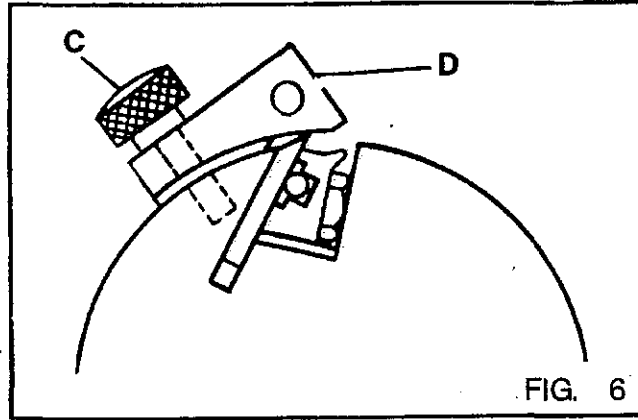

FIG. 6

www.DaltonsWadkin.com

CANTING FENCE (FIG.8)

(OPERATION):-

To adjust the fence across the table simply unlock lever (A) and slide fence by hand to desired position.

On machine fitted with rack and pinion slides (drawn inset) turn handwheel B to move fence across machine.

AFTER ADJUSTING FENCE ENSURE ALL LOCKS ARE ENGAGED BEFORE OPERATING MACHINE.

The fence is capable of canting from 90° (upright) down to 45° and can be adjusted to any required angle between these points by simply unlocking lever (C).

The angle of cant is indicated by scale and pointer (D) whilst positive stops register against the fence carrier bracket at both 90° and 45° .

ADJUSTMENT OF POSITION STOPS

During the working life of the machine it may be required to re-set the cant angle stops (E) (F) in which case the following procedure may be adopted.

90° STOP:-

Set fence to 90° against the scale and check that angle is correct with a steel square from fence to table surface. To adjust stop simply unlock locknut, and screw setting stud inward until tight. Re lock lock nut and operate fence in normal manner to check that adjustment is correct.

45° STOP:-

To re-set the 45° stop (F), firstly set fence over to 45° against the scale then set in same way as outlined above.

FIG. 8.

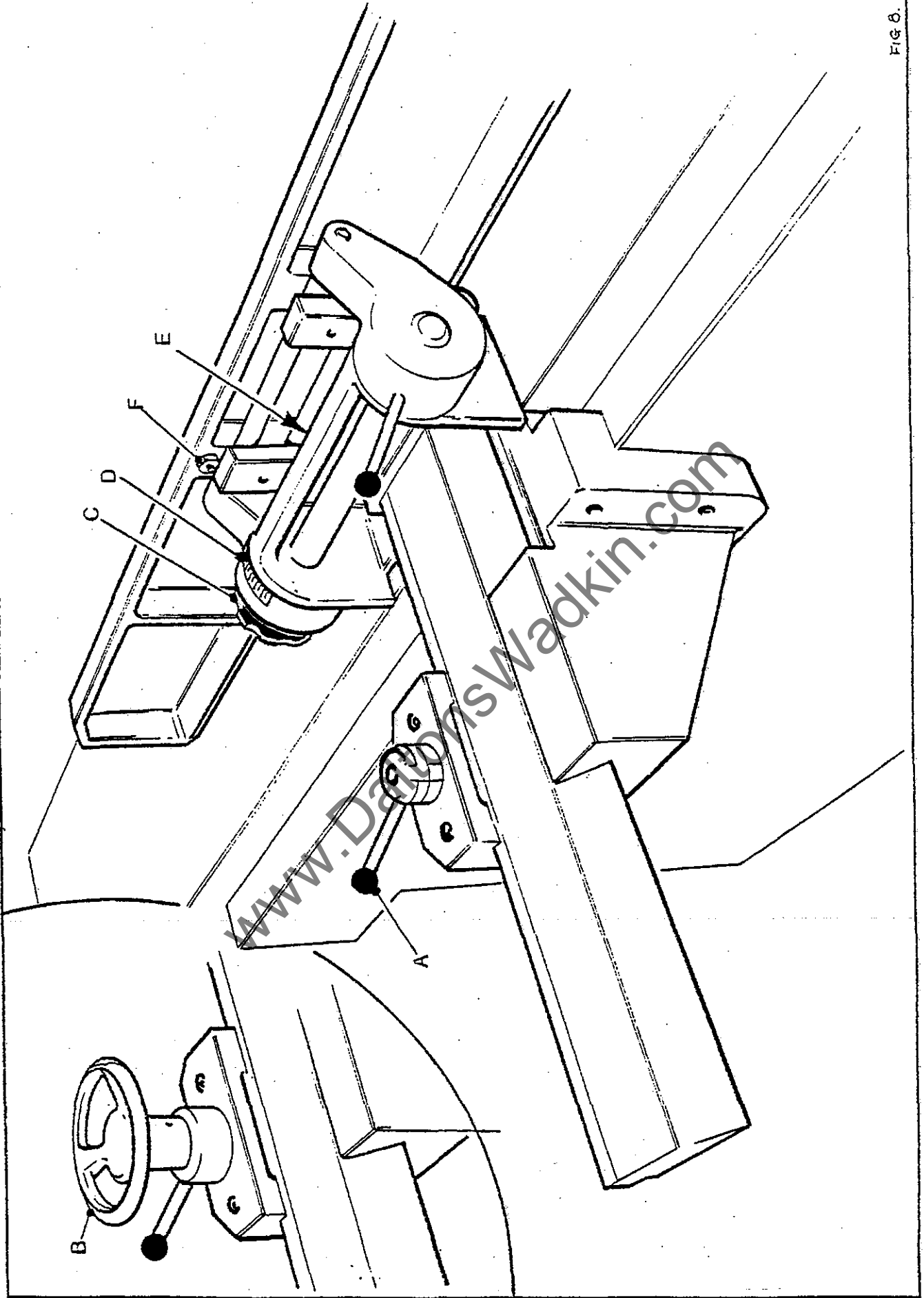

GUARDING:-**TELESCOPIC CUTTERBLOCK GUARD (FIG.9):-**

The telescopic type guard gives complete coverage of the cutterblock and is adjustable both horizontally and vertically.

For vertical adjustment unlock tee-lever (A) and raise or lower as required. Ensure tee-lever is locked firmly after adjustment.

The vertical pillar (B) is fitted with a safety screw at point (C). This ensures that the guard will not drop onto the cutters if accidentally released.

Horizontal adjustment of the guard is by unlocking tee-lever (D) whilst unlocking handwheel (E) will allow the outer guard top cover (F) to slide as required over the inner guard cover (G). The horizontal travel of the inner cover is controlled at either end of the slide by positive stops.

ALWAYS ENSURE ALL POINTS ARE FULLY LOCKED.

NEVER RUN MACHINE WITHOUT GUARDS IN PLACE.

REAR FENCE GUARDING:-

The rear fence cutterblock guard of this machine is provided by the fence slide and gives total protection in this area without the need for adjustment of any kind.

BOOMERANG GUARD (EXPORT ONLY):-

This unit gives full coverage of cutterblock and has built-in spring loaded self return after stock has passed the guard leading edge.

To safeguard against damage during transportation the machine may be supplied with this unit removed, in which case the guard should be re-fitted as shown with the long bolt (A) provided. After re-fitting it may be required to re-tension the spring loading device. This operation is simply undertaken by unlocking grub screws (B) then rotating collar (C). Afterwards re-lock grub screws and check return action of guard before running machine.

SHAW GUARD (COMPULSORY FOR U.K. WHEN REBATING):-

A shaw type guard can be provided for use when rebating and is thoroughly recommended as an additional safety device when undertaking form of work.

For fence fixing positions see illustration.

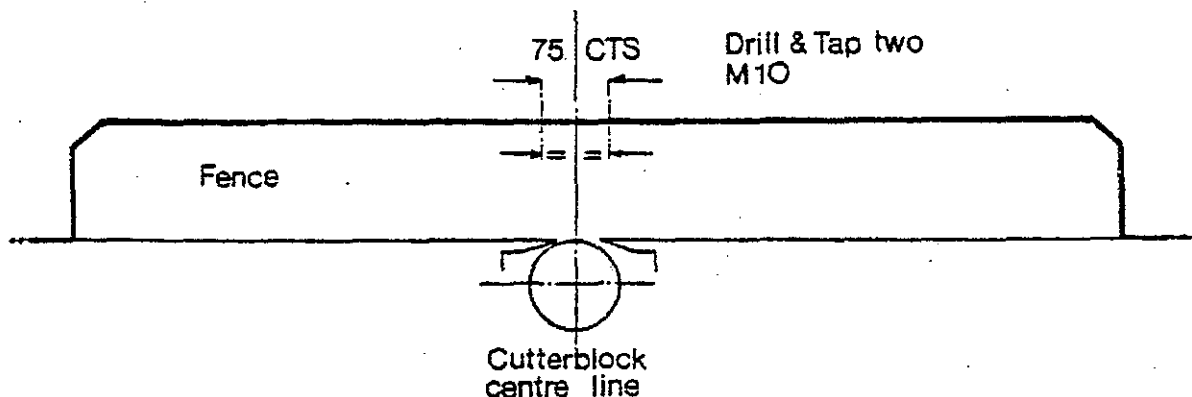

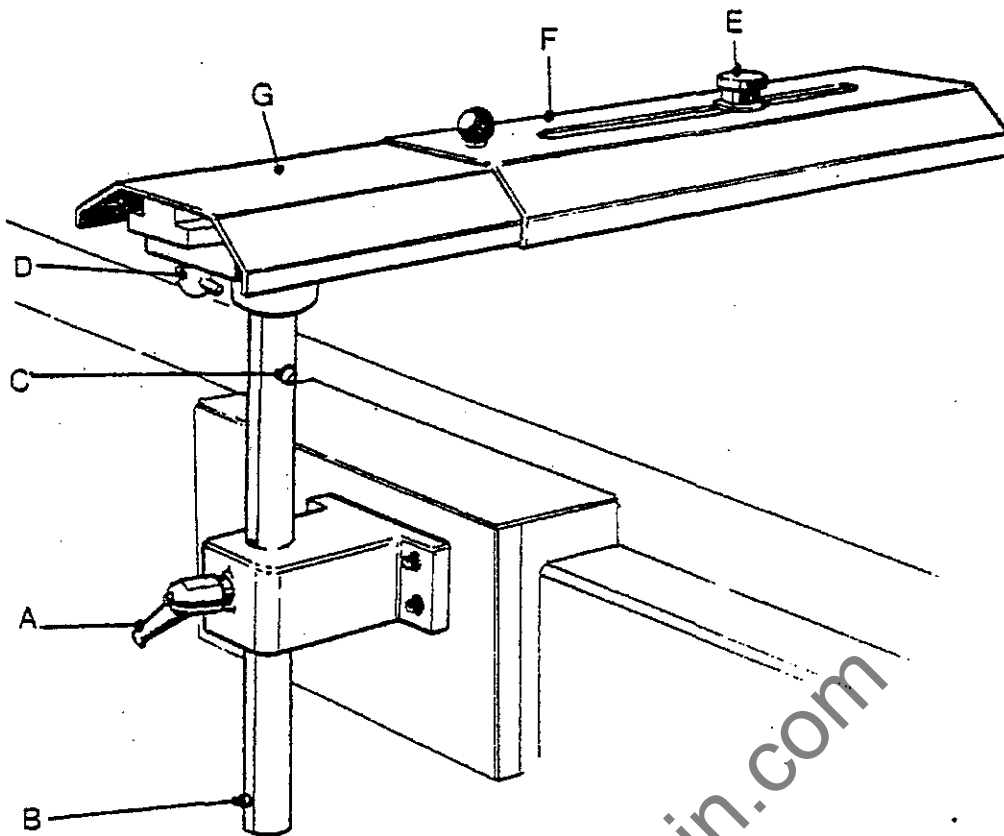

FIG. 9.

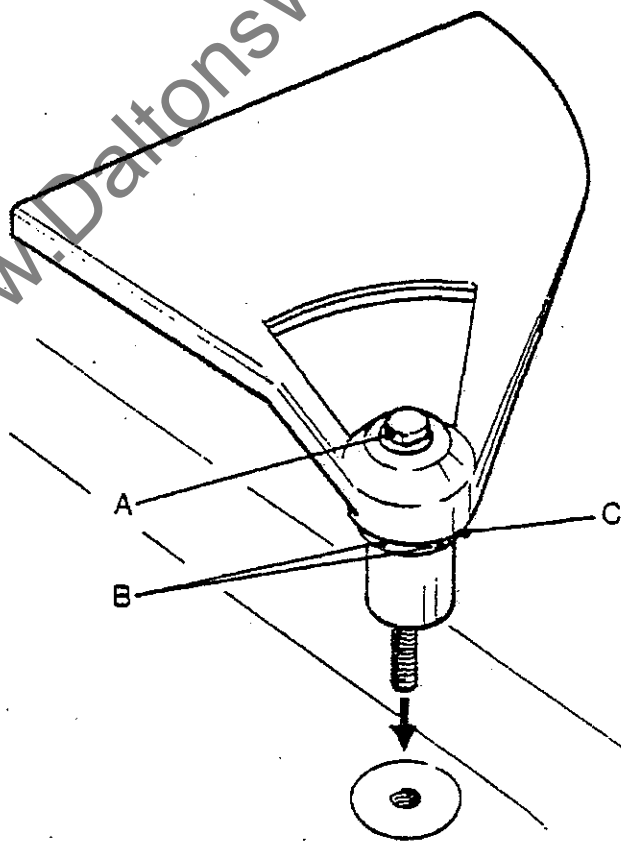

FIG. 10.

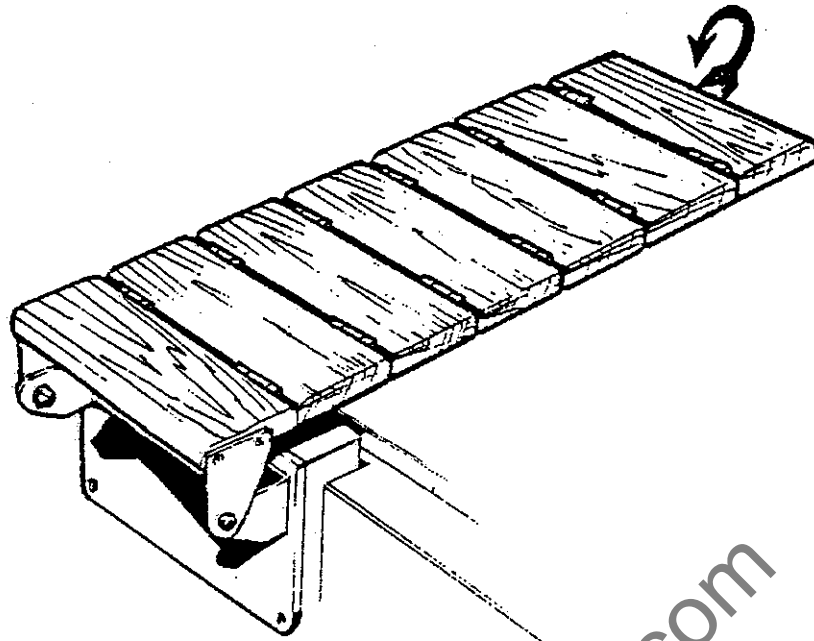

FIG. 11

SEGMENTED ROLL-UP GUARD

On certain export models a special segmented guard can be fitted. Each piece of this unit is hinged separately and as such can be opened to expose the required amount of cutter for individual jobs.

Where required replacement sections can be made from suitable hardwood to the following dimensions.

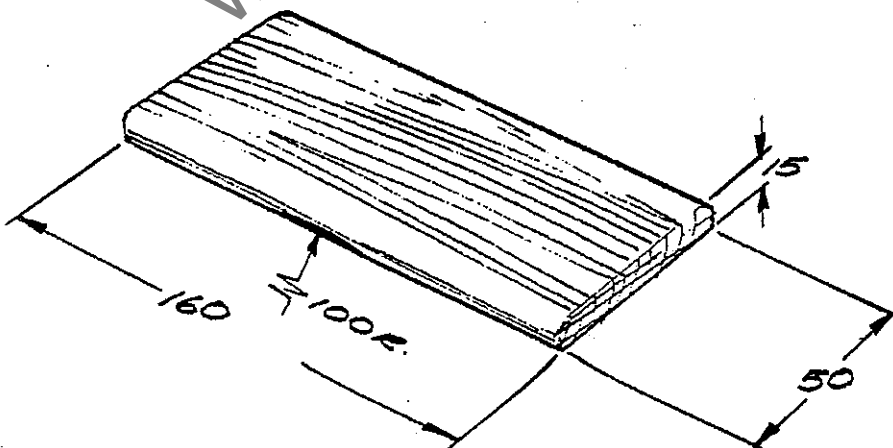

FIG. 12

BELT DRIVE & TENSIONING:-

The drive from the motor to the cutterblock is via two ALPHA 500 vee belts, access to which may be gained by removing the louvered cover at the rear of the machine.

For efficient performance and prolonged belt life it is important to maintain correct belt tension, especially when "running-in" new belts.

A guide to correct belt tension is illustrated in (FIG.12)

To adjust tension simply slacken nut A off two or three turns then slacken nut B in same manner. Carefully screw down nut A until tension is attained as shown in (FIG.11) then lock in this position by tightening nut B against motor foot.

To remove belts slacken nut A off six or seven turns then lift motor by means of a lever placed under motor feet. Withdraw belts over pulley and remove from cutterblock pulley. Place new belts on cutterblock pulley and over motor pulley. Lower motor onto belts and re tension as outlined above.

TREAT DRIVE BELTS WITH CARE:-

Never lever belts from pulleys with sharp implements but use tension facility provided.

Replace any drive belt which is worn or damaged.

Do not over tension belts.

Inspect belts frequently to determine condition.

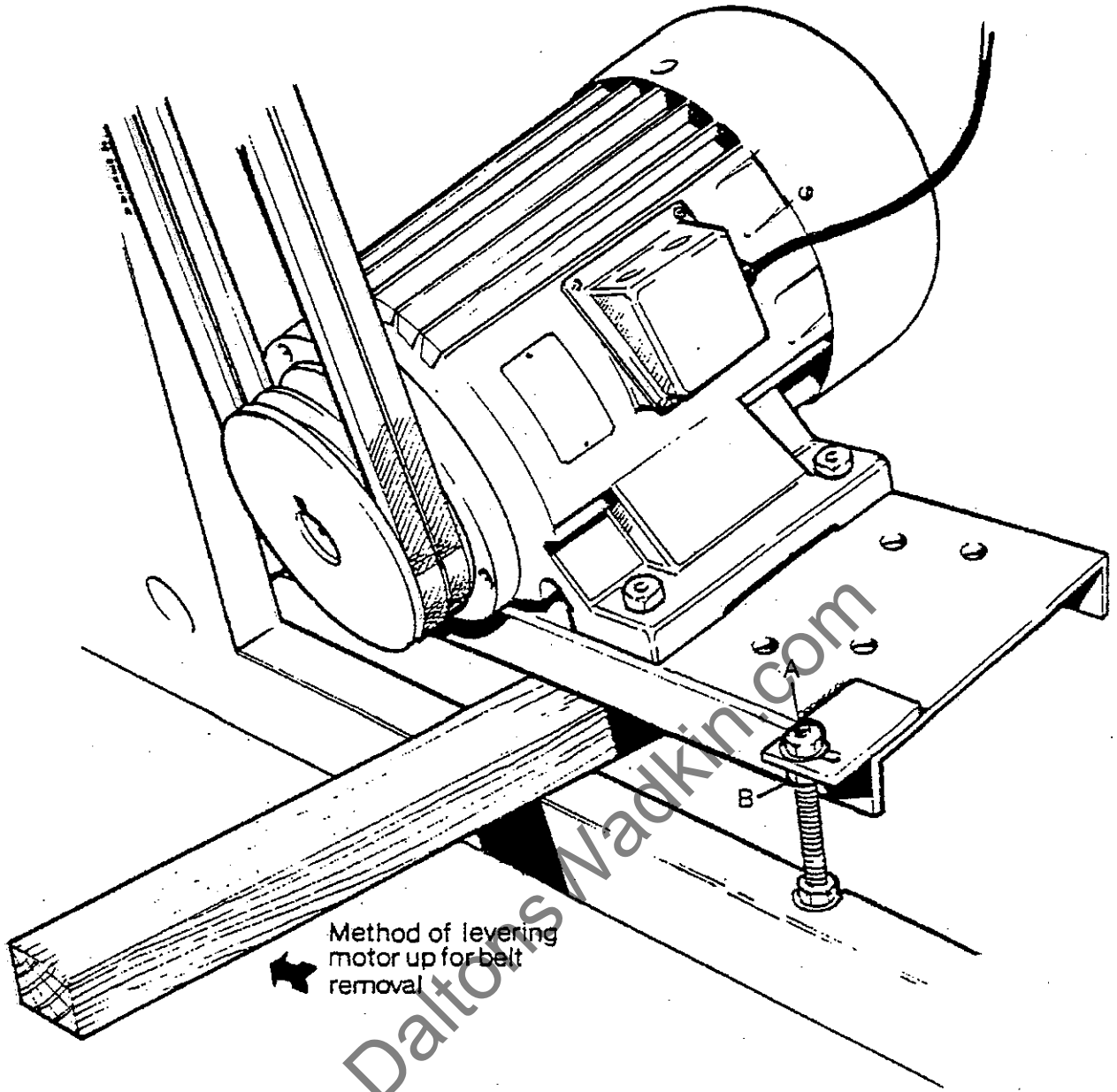

Method of levering motor up for belt removal

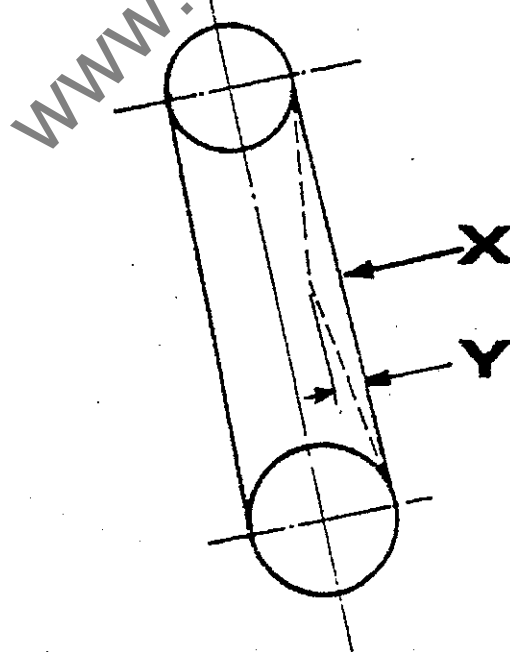

When hand pressure is applied at point X in direction shown by arrow, deflection distance Y should be 6 to 10 mm when correctly tensioned.

LUBRICATION.

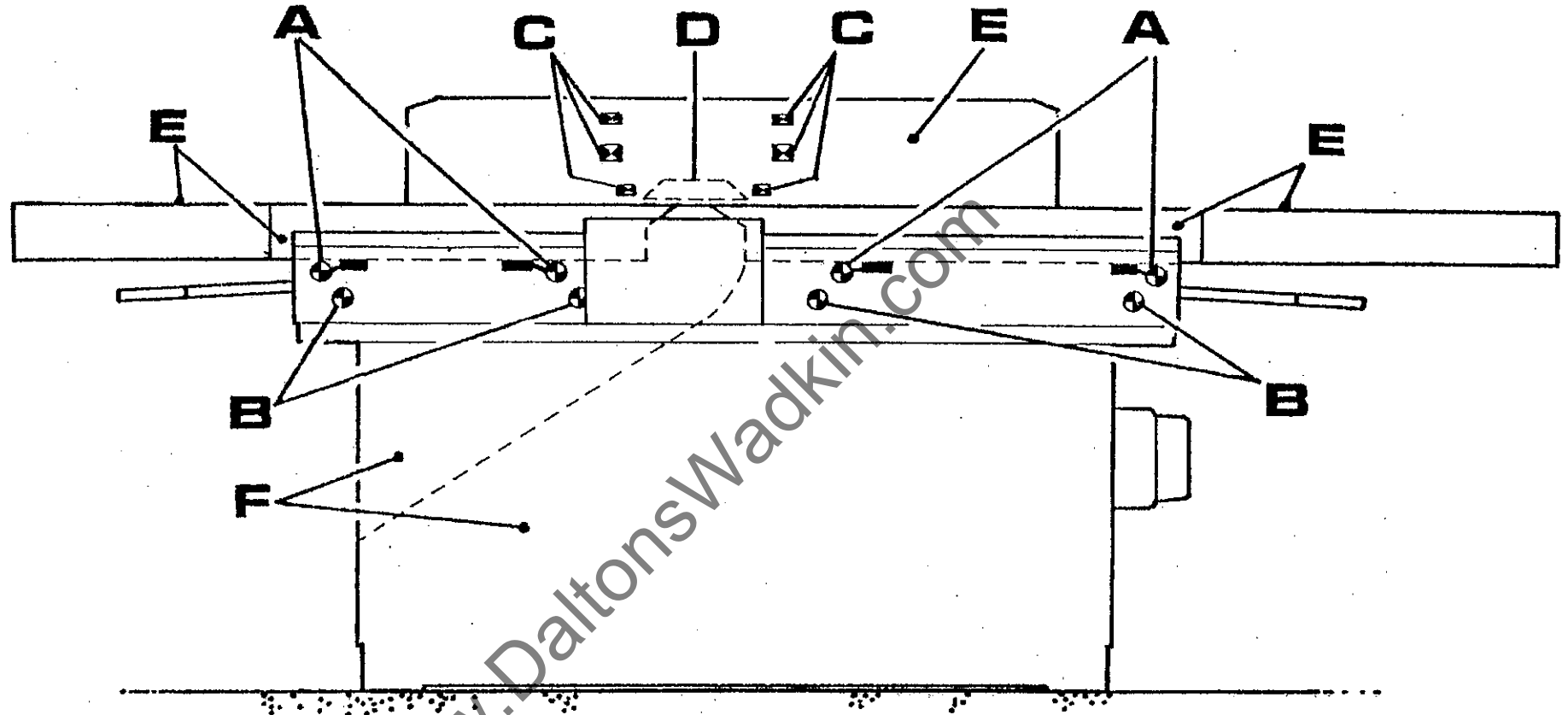

- A** UPPER TABLE PIVOTS • Lubricated from oil reservoir, requires attention at major service period only.
- B** LOWER TABLE PIVOTS • Inject a few drops of oil from the outside MONTHLY.
- C** FENCE CANTING LINKS & PIVOTS • OIL MONTHLY.
- D** FENCE SLIDE • Oil & clean slide faces WEEKLY, keep rack gear clean and smeared with GREASE.
- E** BRIGHT SURFACES • Oil & clean WEEKLY.
- F** BLOW DUST & CHIPS • from inside base & dust chute, also blow machine down DAILY.
DO NOT REMOVE CHIPS FROM CHUTE BY HAND.

8.0 SPARES

8.1 Instructions When Ordering Spare/Replacement Parts

The undermentioned information should be given with all orders requesting spare/replacement parts.

- a) Machine type.
- b) Machine serial number.
- c) If no manual available, give as full a description as possible of the required part, including location within the machine.
- d) Order number and full company name and address.
- e) Company account number, with **Wadkin**, if known.
- f) All telephone orders must be followed by an official order, clearly marked "Confirmation Order".

NOTE: The company operate a 'Minimum Order Charge' on all spare/replacement part orders.