

# S 230 LT

HAND FEED SURFACE  
PLANER.

INSTRUCTION MANUAL

PLEASE INSERT SERIAL NUMBER OF MACHINE

FOR REPLACEMENT PARTS, TOOLS, AND ACCESSORIES CONTACT

BURSGREEN (COLNE) LTD.,

LODGE HOLME,  
TRAWDEN, Nr. COLNE,  
LANCASHIRE,  
BB8 8RB  
ENGLAND

TELEPHONE - 0282 865310

TELEX - 635032 (BURCOL G)

# HEALTH & SAFETY

## SAFETY OF WOODWORKING MACHINES

Woodworking machines can be dangerous if improperly used. The wide range of work of which they are capable, requires adequate safeguarding arrangements against possible hazards.

Many injuries to machinists are caused by carelessness or failure to use the guards provided or to adjust them correctly.

WADKIN LTD., supply machinery designed for maximum safety which they believe, as a result of thorough testing, minimizes the risks inevitable in their use. It is the user's responsibility to see that the following rules are complied with to ensure safety at work:

1. The operation of the machine should conform to the requirements of the Woodworking Machines Regulations 1974. All guards should be used and adjusted correctly.
2. Safe methods of working only should be adopted as given in the Health and Safety Work Booklet No.41, "Safety in the Use of Woodworking Machines", (obtainable from Her Majesty's Stationery Office) and as advised by Wadkin Ltd.
3. Only personnel trained in the safe use of a machine should operate it.
4. Before making adjustments or clearing chips, etc., the machine should be stopped and all movement should have ceased.
5. All tools and cutters must be securely fixed and the speed selected must be appropriate for the tooling.

*SAFETY IS OUR WATCHWORD BUT THE USER MUST COMPLY WITH THE ABOVE RULES IN HIS OWN INTEREST. WE WOULD BE PLEASED TO ADVISE ON THE SAFE USE OF OUR PRODUCTS.*

oOo

WADKIN LTD · GREEN LANE WORKS · LEICESTER LE5 4PF · ENGLAND · TELEPHONE 0533 769111  
and York House, Empire Way, Wembley, Middlesex HA9 0PA      Telex: 34646 (Wadkin Leicester)  
Telephone: 01-902 7714      Telex: 262210      Telegrams: Woodworker Leicester Telex

# Wadkin Bursgreen

## SPECIFICATION

Planing capacity .. .. .	230 mm
Length of tables .. .. .	2100 mm
Speed of cutterblock .. .. .	5000 U/min
Cutting circle of cutterblock .. .. .	90 mm
Length of fence .. .. .	915 mm
Height of fence .. .. .	120 mm
Fence will cant to .. .. .	45°
Will rebate up to .. .. .	12 mm
Rise and fall of tables .. .. .	16 mm
Horse power of driving motor – 3 phase .. .. .	1,5 kW
1 phase .. .. .	0,75 kW
Syn. speed of motor, 50 hertz .. .. .	3000 U/min
Height of table from floor .. .. .	800 mm
Approx. floor space .. .. .	2100 x 550 mm
Approx. net weight .. .. .	240 kg
Approx. gross weight .. .. .	300 kg
Shipping dimensions .. .. .	1,2 m <sup>3</sup>

www.DaltonsWadkin.com

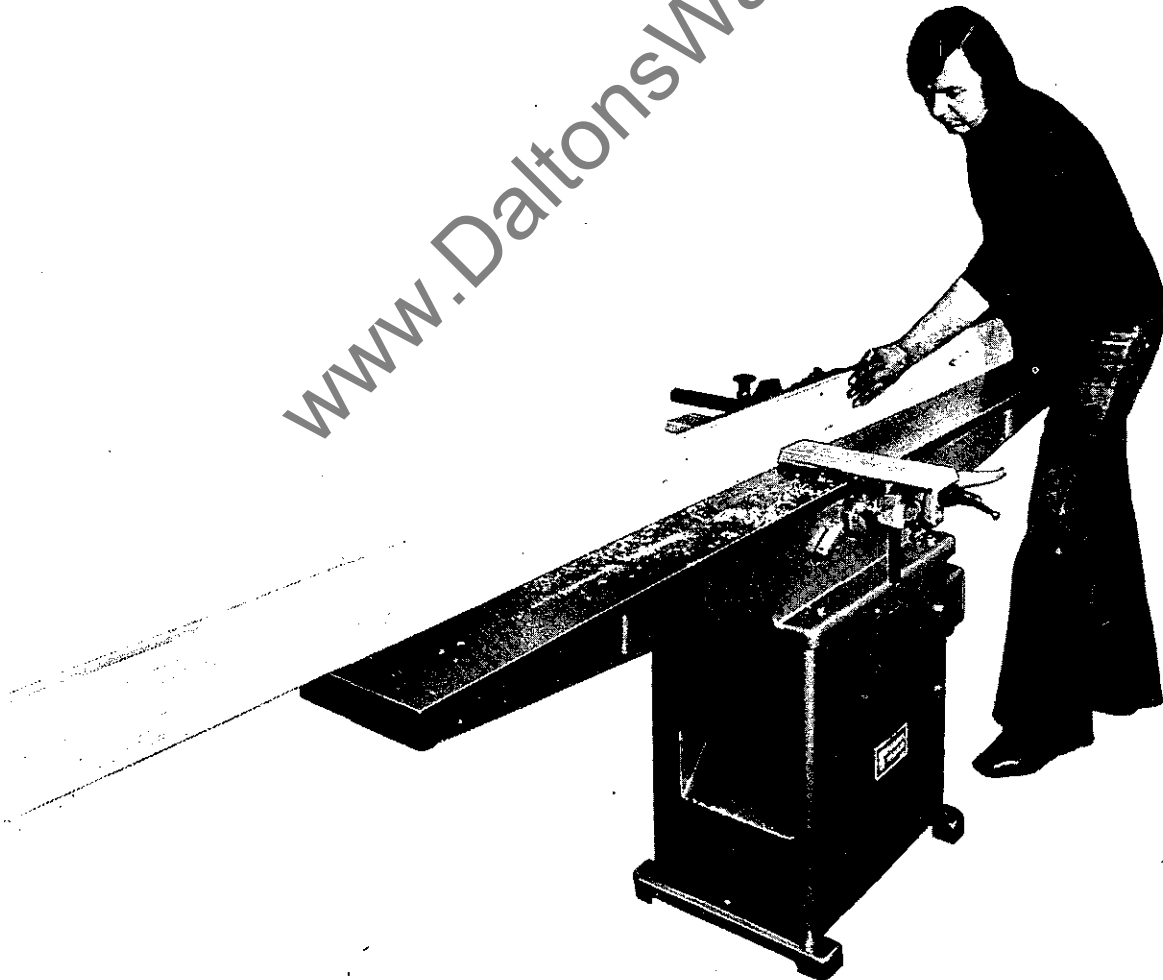

②

Installation:-

Remove protective anti-rust coating from bright parts by applying a cloth soaked in paraffin or other solvent.

Wiring:-

The motor and control gear have been wired in before despatch, therefore all that is required to be done is to connect the mains supply to the starter, or isolator where fitted.

POINTS TO NOTE WHEN CONNECTING TO POWER SUPPLY.

- 1 - Check voltage, phase and frequency
- 2 - It is important that the correct cable is used to deliver the correct voltage to the starter. RUNNING ON LOW VOLTAGE WILL DAMAGE MOTOR.
- 3 - Check main line fuses are of correct capacity.
- 4 - Connect line leads to correct terminals (SEE WIRING DIAGRAM).
- 5 - Check all connections are sound.
- 6 - Check spindle rotates in correct direction. If not reverse any two of the line lead connections

FAILURE TO START:-

- 1 - Fuses have blown or have not been fitted.
- 2 - Isolator switch has not been closed.
- 3 - Lock off or stop button (when fitted) has not been released.
- 4 - Supply not available at machine.

STOPPAGE DURING OPERATION & FAILURE TO RESTART:-

- 1 - Overloads have tripped. If hand re-set, set by pressing button. If automatic they will re-set after a short period.
- 2 - Fuses have blown.

Foundation:-

The machine should be levelled and bolted down firmly. For mounting into concrete, 6" to 8" square holes should be cut in the floor and rag bolts fitted, after which the holes should be run with cement. For mounting on wood floors coach bolts will be found adequate. (see Fig. B2 )

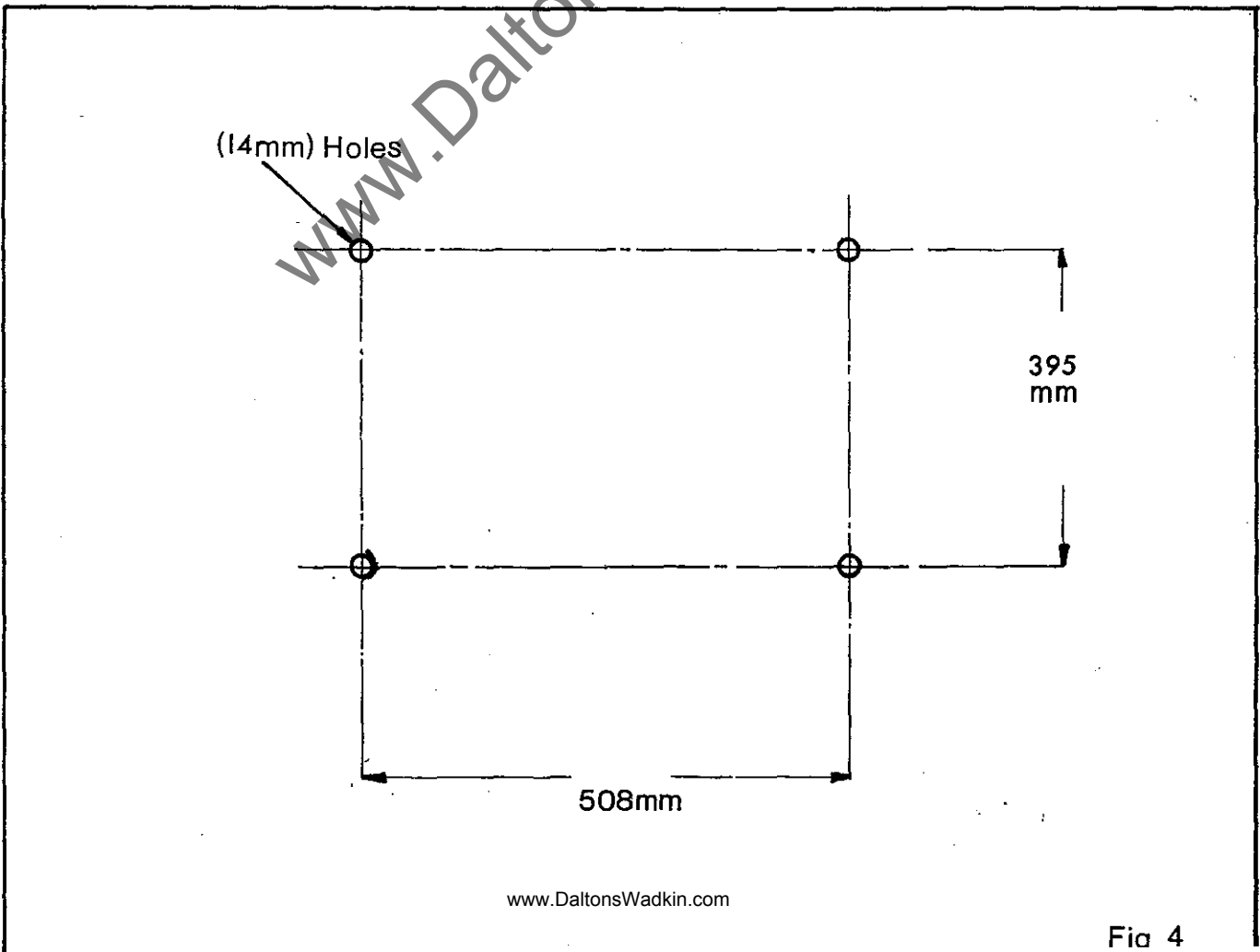
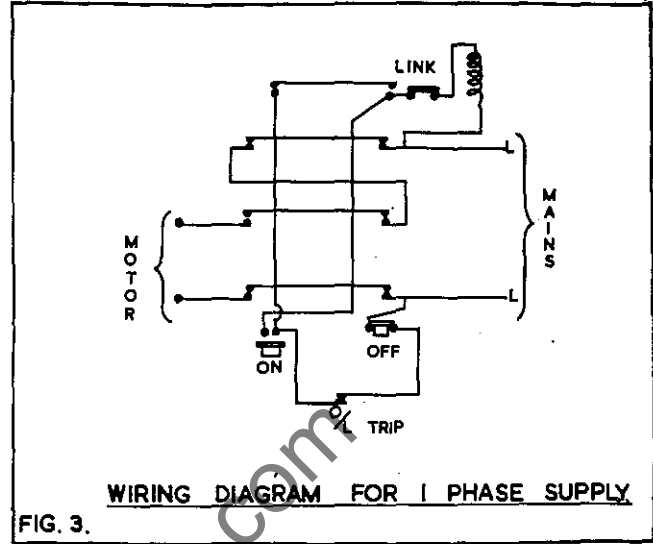
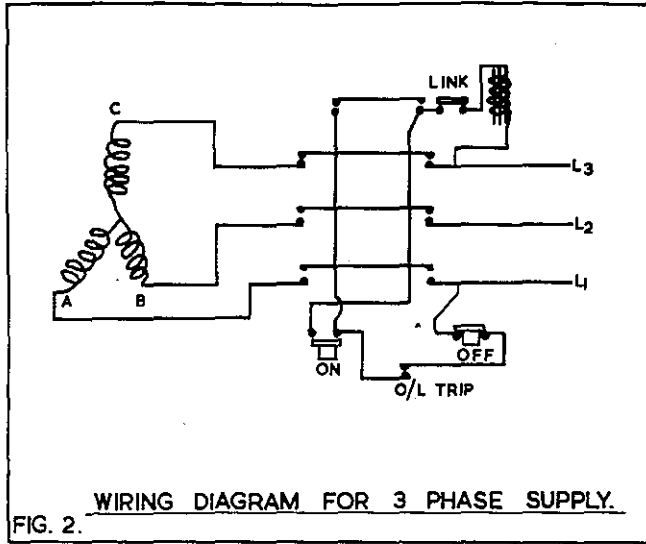

4

CUTTER SETTING

The knives are held in the cutterblock by a steel clamping bar secured with 4 - 10 mm heat treated socket head screws. When the locking screws are released the cutters are ejected slightly by a small leaf spring. This is to facilitate easy cutter setting with the special gauge supplied. As the amount of cutter projection is vital to the correct operation of the machine it is most important that the actual gauge supplied with the machine should be used. Should any other method of cutter setting be employed the amount of cutter projection must be exactly the same as with that given by the setting gauge supplied and failure to observe this instruction will result in poor finish. To remove the cutters and re-set with "Bursgreen" cutter setting gauge proceed as follows :-

1. Move the fence to rear of the table and lower both planing tables to their lowest position.
2. Turn the cutterblock to approximately the position shown in Fig. 5 and slacken the securing screws until the knife is just free of the cutterblock. Care should be taken when loosening the last screw as the knives are spring loaded. The knives can now be removed for grinding or replacing. When grinding it is most important that knives are ground dead straight and balanced in pairs or sets.
3. To re-set the knives, the cutterblock should be in approximately the position shown in Fig. 5 Place the knife in the slot making sure that all faces are clean and the clamping bar free from burrs. Press the knife into the cutterblock with the setting device in Fig. 5 until the four predominant pads rest on the outer surface of the cutterblock and the end stop plate is pressed against the rebate side of the back planing table. Position the knife so that its end butts against the stop plate so as to line up the tip of the knife with the edge of the back table.
4. Holding the setting device securely in this position, tighten the securing screws. Before fully tightening the screws, check that they have not moved in the setting process. The cutting edge should now be dead parallel to the planing tables and the edge in line with the back planing table edge. Check that all the securing screws have been tightened before setting the next knife.
5. Rotate the cutterblock until the next knife is in position and repeat the procedure until all the knives have been set.
6. To check the setting of the knives raise the back table to its top position i.e. the zero mark on the rule or 1.5mm above the outer surface of the cutterblock. Place a straight edge on the table as shown in Fig. 6 and rotate the cutterblock by hand until the knife just touches the straight edge. Repeat this check in various positions over the width of the table to ensure the knife is parallel. Repeat this procedure for all knives.
7. When changing cutters it is advisable to check that all the locking screws are adequately lubricated and quite free. Periodically examine for damage or cracks particularly in the hexagon hole. Any doubtful screws should be replaced and all screws well lubricated with "Molyslip" or similar oil, before replacing.

CUTTER CARE

The cutters supplied are  $9\frac{1}{4}$ " (235 mm) long x  $1\frac{1}{4}$ " (32 mm) wide x  $1/8$ " (3mm) thick in balanced sets. They should be kept in balanced sets by ensuring that the cutters have equal dimensions after grinding and that the cutter edge is straight and parallel to the back edge.

For general work, knife angles for soft and hard woods are recommended as in Fig. 7 (a) and (b).

When a very fine finish is required in dry soft and hard woods a slight front bevel is given as in Fig. 7 (c) and (d). For wet or green timber the cutting bevel may be decreased five degrees, but the front bevel should not be given.

Keep the cutters sharp when in position by using a fine grade oil stone dipped in paraffin. Allow the stone to rest lightly and flat on the bevel and pass over the cutter with a rotating action a few times. Give about two strokes on the full length of each knife on the face side to remove all burrs from the cutting edge.

Do not allow a heel greater than  $1/32$ " wide on the bevel before removing and re-grinding. When the heel becomes too wide the knives may heat up or have a hammering

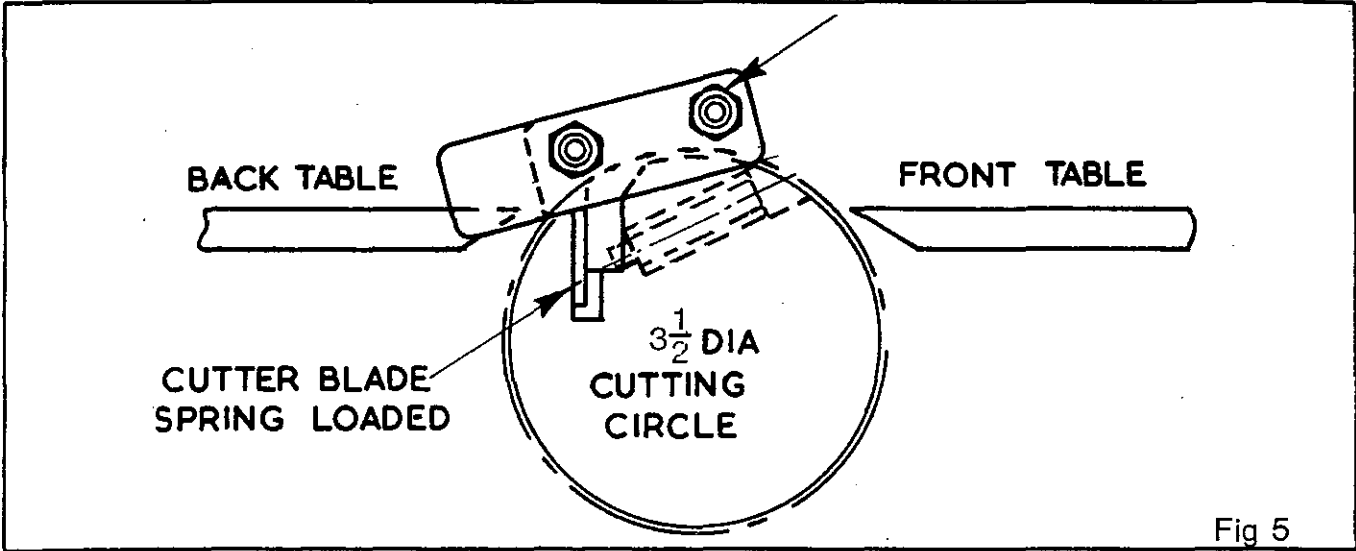

Fig 5

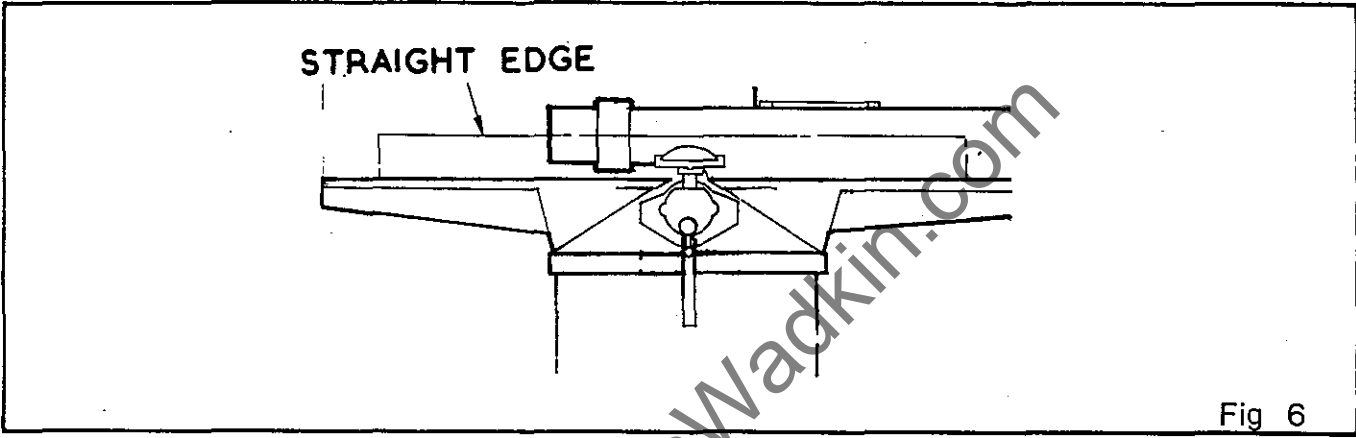

Fig 6

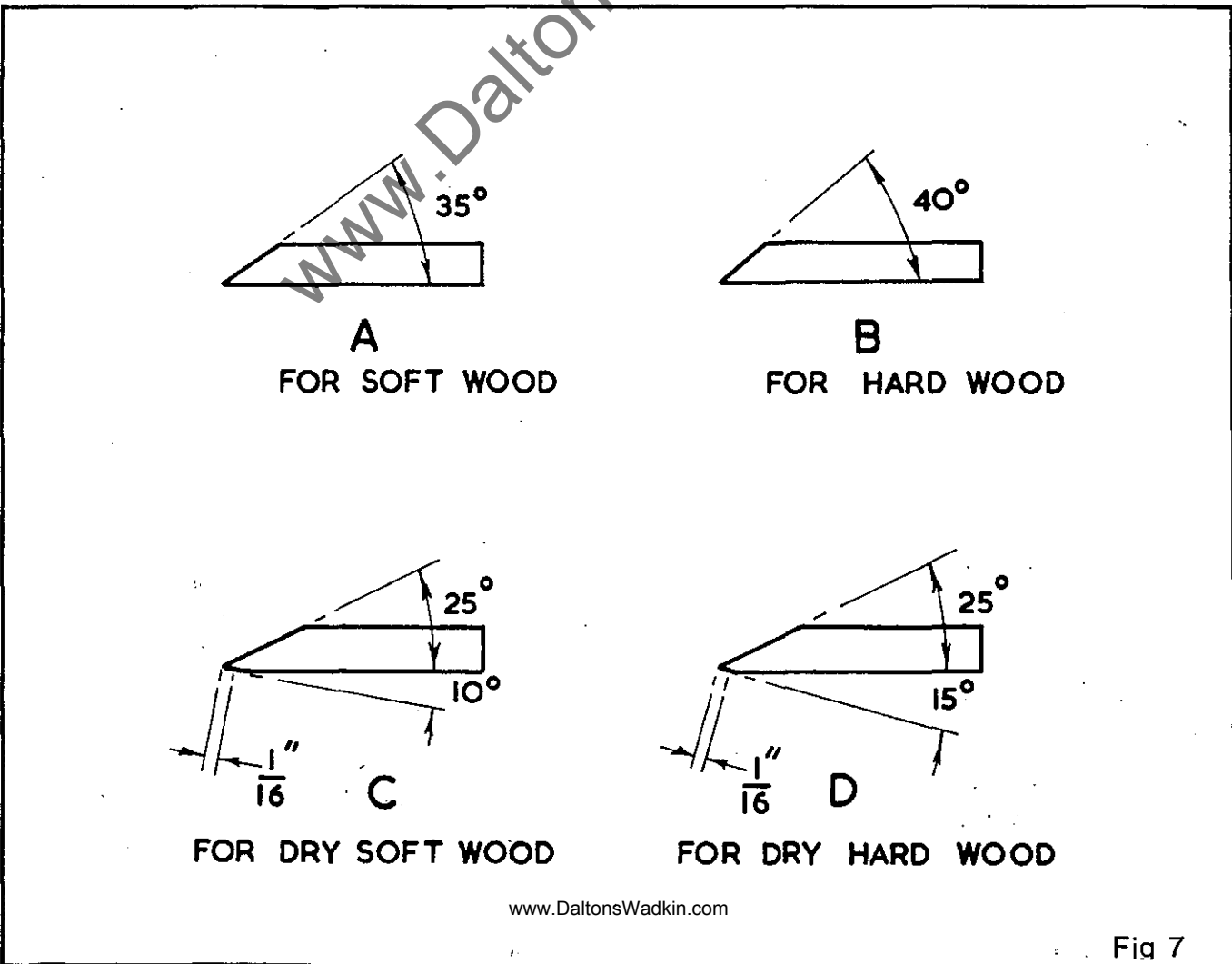

Fig 7

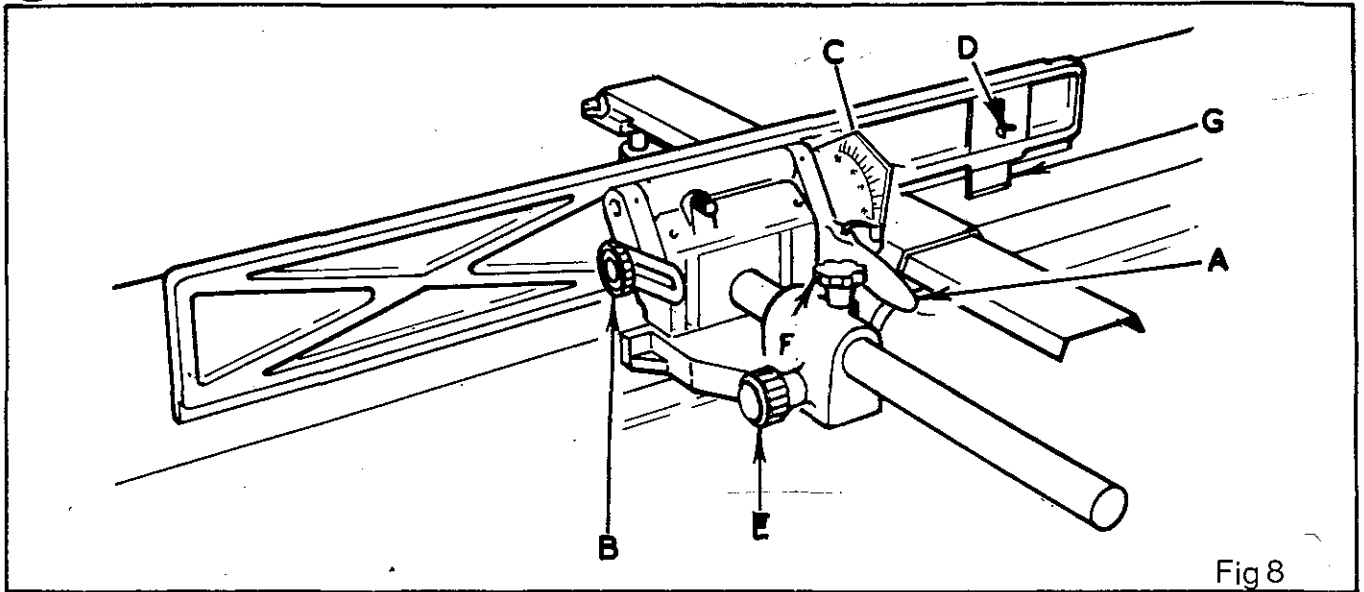

Fig 8

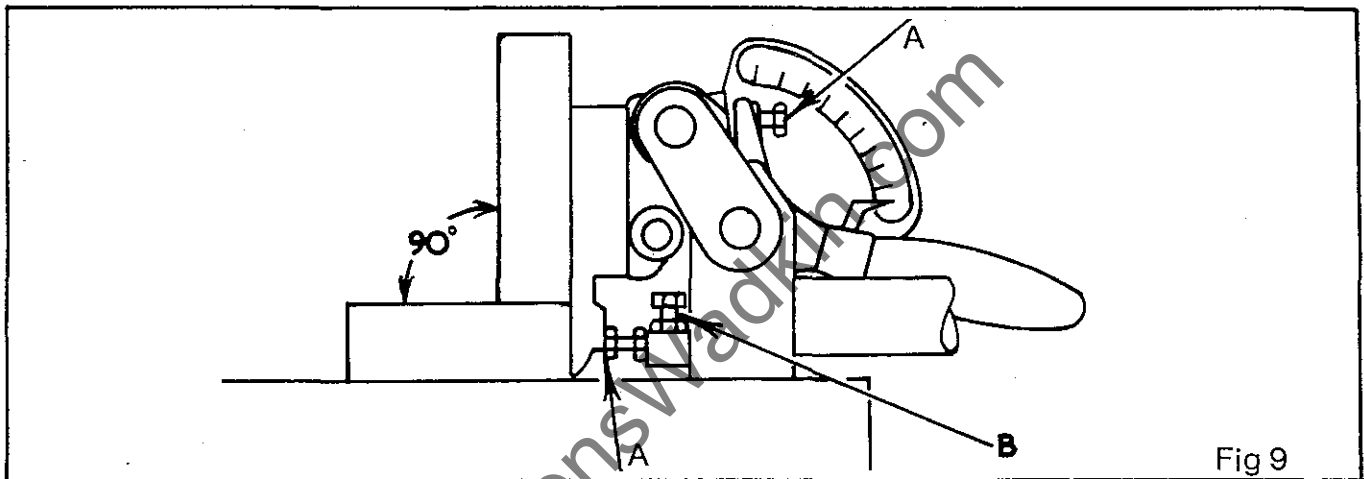

Fig 9

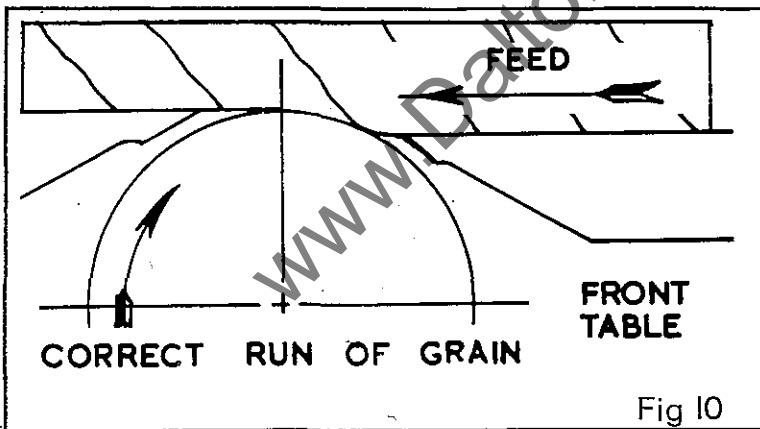

Fig 10

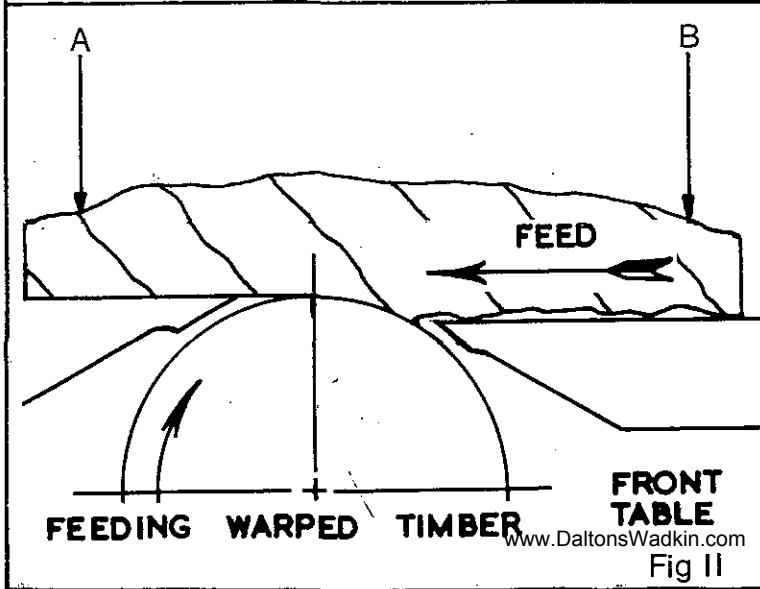

Fig 11

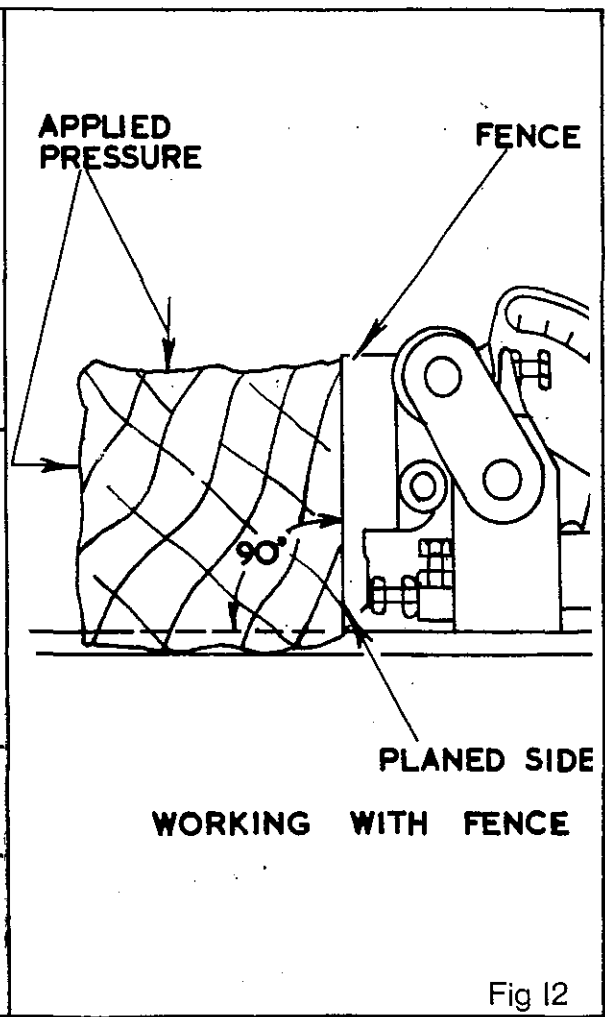

Fig 12



## FENCE ADJUSTMENT

The fence cants by means of a single lever "A" in Fig. 8 to  $45^{\circ}$ . The angle to which the fence is canted is shown on a graduated scale "C".

To cant the fence to the required angle loosen the handwheel "B" and lift handle "A" until the required angle is shown on the graduated scale "C", then re-lock handwheel "B".

The fence front plate is fitted with an insert "G" which is over the rear planing table and is adjustable depending on the depth of cut which is being taken. To adjust the insert loosen the wing nut "D" and move the insert until it just touches the rear planing table then re-lock wing nut "D". The insert should be loosened at all times before lowering the front planing table.

The fence is also adjustable across the full width of the table by means of a rack and pinion. To adjust the fence across the table loosen the handwheel "E", and turn the handwheel "F" in the direction which the fence is required to move, until the required position is reached, then re-lock handwheel "E".

The fence should be locked in both positions at all times when the machine is in operation.

The fence has positive stops at  $90^{\circ}$  and  $45^{\circ}$ . These are both accurately set before despatch from the works.

To check the positive stops on the fence the undermentioned procedure should be followed:-

1. Move the fence towards the rear of the table as shown in Fig. 9
2. Check the  $90^{\circ}$  positive stops by means of a steel square as shown in Fig. 9. If adjustment is necessary, adjust the hexagon head bolts "A" until the fence is at right angles to the table when hard up against the stops and the handwheel "B", in Fig. 8 locked.
3. Check the  $45^{\circ}$  positive stop by means of an adjustable square. If adjustment is necessary, adjust the socket head grub screw "B" until the fence is  $45^{\circ}$  to the table when hard up against the stop and the handwheel "B" in Fig. 8 locked.
4. If adjustment is necessary to the positive stops check that the graduated scale is still correct. This is secured to the support bar by means of a socket head grub screw. This should be loosened and the scale accurately positioned to the pointer.

## GENERAL HINTS FOR SURFACE PLANING

1. To obtain the best surface finish always check the direction of the grain, which should run with the cutter as shown in Fig. 10
2. To obtain a perfectly flat surface especially with warped stock, always put maximum pressure on the back table at "A" in Fig. 11 and as little as possible on the front table at "B".
3. Greater pressure will be required when surfacing bad grained timber, otherwise chattering will take place resulting in coarse finish near each knot.
4. When planing four sides of timber, square turn the timber anti-clockwise after each cut, so that there will always be a machined face next to the fence as in Fig. 12. The fence locates accurately at  $90^{\circ}$ .

# LUBRICATION

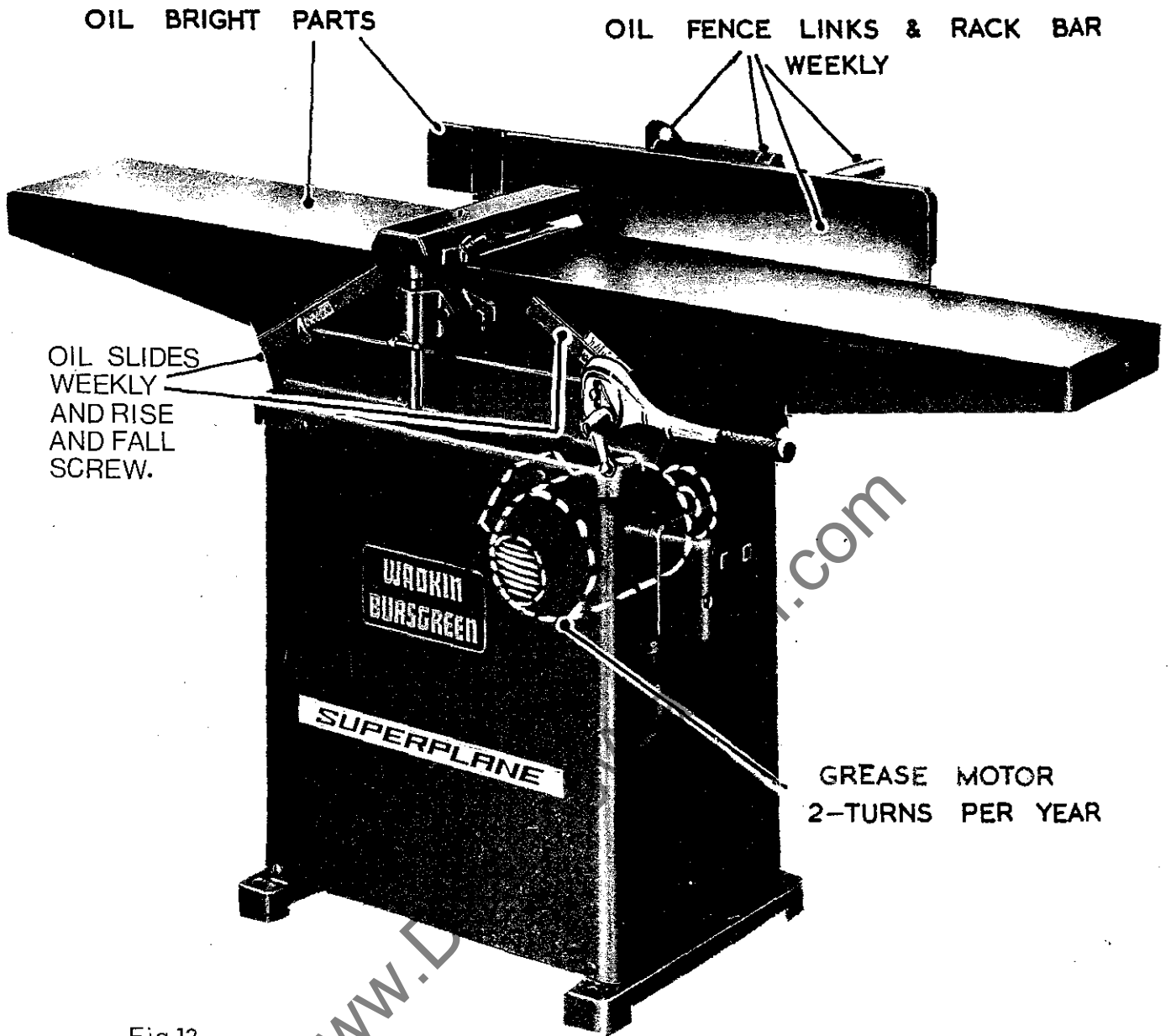

Fig 13

## WADKIN OILS & GREASES WITH RECOMMENDED ALTERNATIVES

Wadkin Grade	Castrol Equivalent	Mobil Oil Co. Equivalent	Shell Equivalent	Regent/Caltex/Texaco
L. 2	Alpha 417	Mobil Dte Oil BB	Vitrea Oil 69	Meropa 2
L. 4	Perfecto NN	Mobil Vactra Oil Heavy Medium	Vitrea Oil 33	Ursa P. 20
L. 6	Spheerol AP3	Mobilux Grease No. 3.	Alvania Grease No. 3.	Regal/Starfak Premium 3

## SPARE PARTS LISTS

[www.DaltonsWadkin.com](http://www.DaltonsWadkin.com)

### **NOTE**

PLEASE NOTE WHEN ORDERING SPARE PARTS GIVE FULL DESCRIPTION ON YOUR ORDER. DETAILS SHOULD BE WRITTEN CLEARLY AND EXACTLY AS LISTED IN THE PARTS SECTION OF THIS MANUAL

MAIN FRAME ASSEMBLY

REF NO.	PART NO.	QTY	DESCRIPTION
1.	C1076-3	2	FOOT FOR BASE.
2.	B1031-53	1	PANEL FOR BASE.
3.	D1075-102	1	BASE
4.	C1075-89	1	MOTOR PLATFORM (FAN END).
5.	C1075-90	1	" " (PULLEY END).
6.	A1075-18	2	MOTOR PLATFORM COVER PLATE.
7.		1	BROOK GRYPHON 2HP 3000 RPM T.E.F.C. MOTOR.
8.	A1075-8	1	MOTOR PULLEY.
9.		1	M.E.M. 44 ADS STANDARD STARTER.
10.	B1075-27	1	"SUPERPLANE" NAMEPLATE DECAL.
11.		1	WADKIN BURGEEEN NAMEPLATE.
12.		6	M6 X 10MM LONG COUNTERSUNK SCREWS.
13.		6	M8 X 25MM LONG HEXAGON HEAD BOLTS.
14.		18	M8 X 16MM LONG " " "
15.		6	M8 NUTS.
16.		6	M8 WASHERS.
17.		4	$\frac{3}{8}$ " WHIT X $\frac{3}{4}$ " LONG HEXAGON HEAD BOLTS.
18.		4	$\frac{3}{8}$ " WASHERS.
19.		1	$\frac{3}{16}$ " SQ X $1\frac{5}{8}$ " LONG S.R.E. KEY.
20.		2	M6 X 20 LONG ALLEN GRUB SCREWS.
21.		1	ALPHA 400 SPZ1010 DRIVE BELT.
22.		1	DEMCO $\frac{3}{4}$ " BORE PISTOL GRIP HANDLE.
23.	C1075-35	1	TABLE RISE AND FALL LEVER.
24.		1	M10 X 40MM LONG HEXAGON HEAD BOLT.
25.	A1075-37	1	PIVOT BUSH FOR RISE AND FALL LEVER.
26.	A1075-60	1	M12 X 85MM LONG RISE AND FALL LEVER STUD.
27.		1	12MM I/D X 18MM O/D X 20MM LONG JIG BUSH.
28.		2	12MM BELVILL WASHER NO. 10.
29.		1	M12 AEROTIGHT LOCKNUT.
30.	A1075-61	1	SHROUD FOR RISE AND FALL LEVER.
31.		1	M12 LEVER HANDLE.
32.		4	M6 X 30MM LONG ALLEN SCREWS.
33.	A1075-49	2	BRACKET FOR TABLE RISE AND FALL RULE.
34.	A1075-54	2	ENGLISH/METRIC TABLE RULE (A1075/55 ENGLISH ONLY).
35.		4	$\frac{1}{8}$ " WASHERS.
36.		14	$\frac{1}{8}$ " WHIT X $\frac{1}{4}$ " LONG ROUND HEAD SCREWS.
37.		4	M12 X 40MM LONG HEXAGON HEAD BOLTS.
38.	A1075-103	1	MAIN FRAME ADJUSTMENT SCREW.
39.	E1075-1	1	MAIN FRAME.
40.	A1075-91	1	TABLE STOP PLATE.
41.	C1075-70	1	BELT GUARD.
42.	A1075-5	1	TABLE RISE AND FALL SCREW NUT.
43.		2	M6 X 10MM LONG ALLEN GRUB SCREWS.
44.	SKF 51102	2	THRUST RACES.
45.	A1075-40	1	TABLE RISE AND FALL SCREW.
46.	6687/54	1	$2\frac{1}{8}$ " DIA X M12 BORE (BLIND) RISE AND FALL HANDLE.
47.		1	$\frac{1}{8}$ " DIA X 1" LONG DOWEL.
48.	A1075-48	2	RISE AND FALL POINTER (STATE IF EITHER RIGHT OR LEFT HAND).
49.	B1075-87	2	TABLE GIB STRIP.
50.	B1075-21	2	CHIP DEFLECTOR.
51.	A1076-38	4	SLIDE STRIP ADJUSTER SCREW (M8 X 16MM).
52.	E1075-14A.	1	OUTFEED TABLE.
53.	E1075-14B.	1	INFEED TABLE.
54.		3	M6 X 16MM LONG HEXAGON HEAD BOLTS.

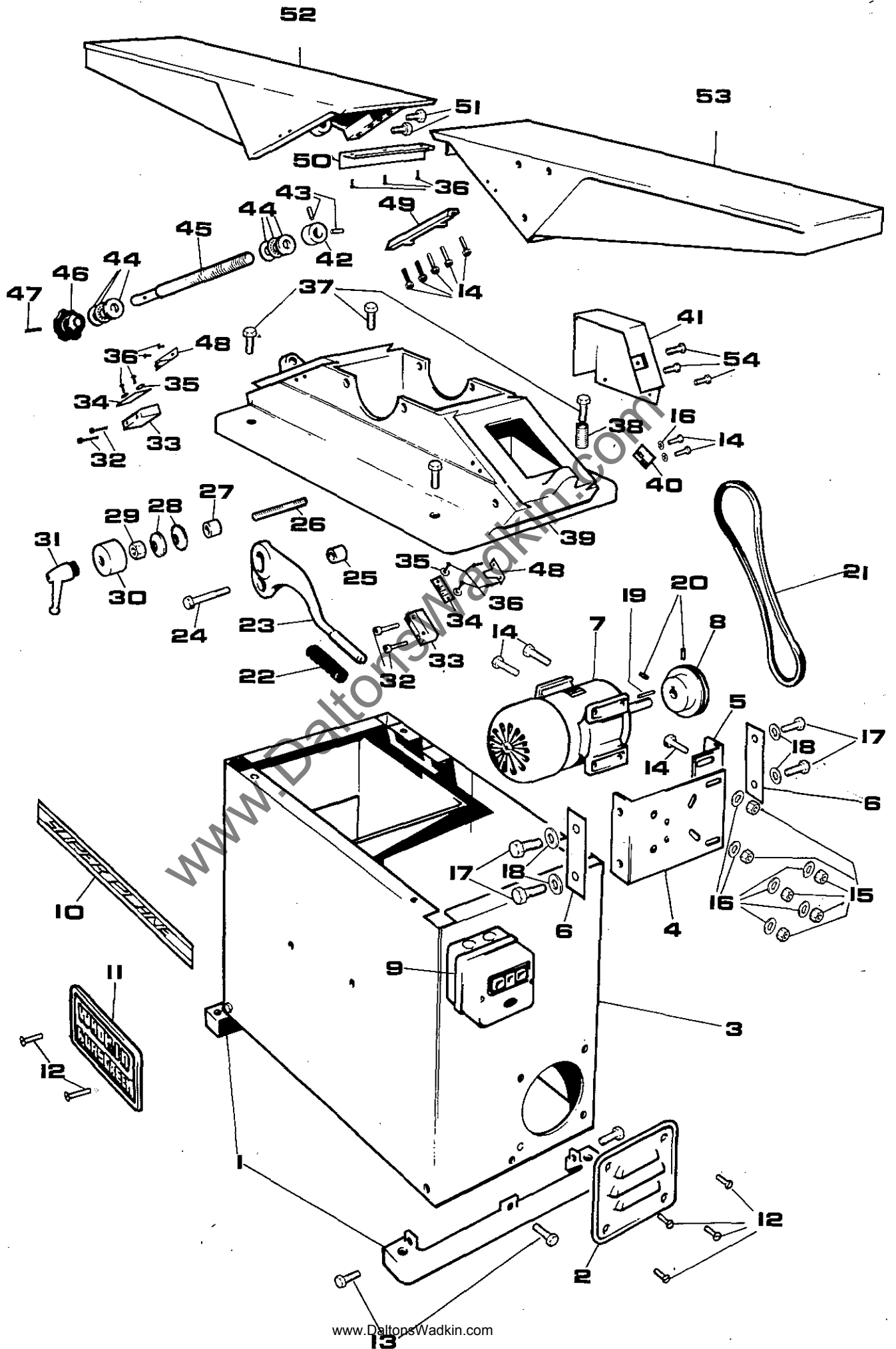

12

CUTTERBLOCK ASSEMBLY

REF NO.	PART NO.	QTY.	DESCRIPTION.
60.		2	M8 X 20MM LONG ALLEN SCREWS.
61.	STOCK	1	$\frac{3}{8}$ " WHIT TEE LOCK HANDLE.
62.		4	5MM DIA X 30MM LONG DOWELS.
63.		4	M10 X 30MM LONG HEXAGON BOLTS.
64.	B1075-4	1	REBATE SIDE BEARING HOUSING.
65.		1	M10 X 20MM LONG HEXAGON BOLT.
66.		1	$\frac{5}{8}$ " BSF LEFT HAND NUT.
67.	A1075-68	1	WASHER FOR CUTTERBLOCK.
68.		2	52MM INTERNAL CIRCLIPS.
69.		2	SKF 6205-2RS SEALED BEARINGS.
70.	B1075-12	1	DRIVE SIDE BEARING HOUSING.
71.	A1075-7	1	CUTTERBLOCK PULLEY (50 CYCLES).
71.	A1075-65	1	" " (60 CYCLES).
72.	A1075-51	1	CUTTERBLOCK PULLEY WASHER.
73.	BVP 37	2	PLANER BLADES (2 KNIFE BLOCK).
73.	BVP 37	3	" " (3 KNIFE BLOCK).
74.	A1075-20	2	CUTTERBLOCK WEDGES (2 KNIFE BLOCK).
74.	A1075-20	3	" " (3 KNIFE BLOCK).
75.	BFR 412	2	CUTTERBLOCK BLADE SPRING (2 KNIFE BLOCK).
75.	BFR 412	3	" " (3 KNIFE BLOCK).
76.		2	$\frac{1}{8}$ " SELF LOCK RIVET (2 KNIFE BLOCK).
76.		3	" " (3 KNIFE BLOCK).
77.	A1075-50	8	BLADE LOCK SCREWS (2 KNIFE BLOCK).
77.	A1075-50	12	" " (3 KNIFE BLOCK).
78.		1	$\frac{5}{16}$ " X $\frac{5}{16}$ " X 1" LONG S.R.E. KEY.
79.	C1075-19	1	CUTTERBLOCK (STATE IF 2 OR 3 KNIFE).
80.	A1075-22	1	CUTTERBLOCK GUARD ADJUSTMENT BAR.
81.		1	$\frac{1}{8}$ " GAS X $\frac{3}{8}$ " LONG GRUB SCREW.
82.	B1075-24	1	FRONT BRIDGE GUARD BRACKET.
83.	A1075-41	1	CUTTERBLOCK GUARD LOCKING PIN.
84.	B1029-88	1	FRONT BRIDGE GUARD.
85.		1	M10 WASHER.
86.		1	M10 WINGNUT.

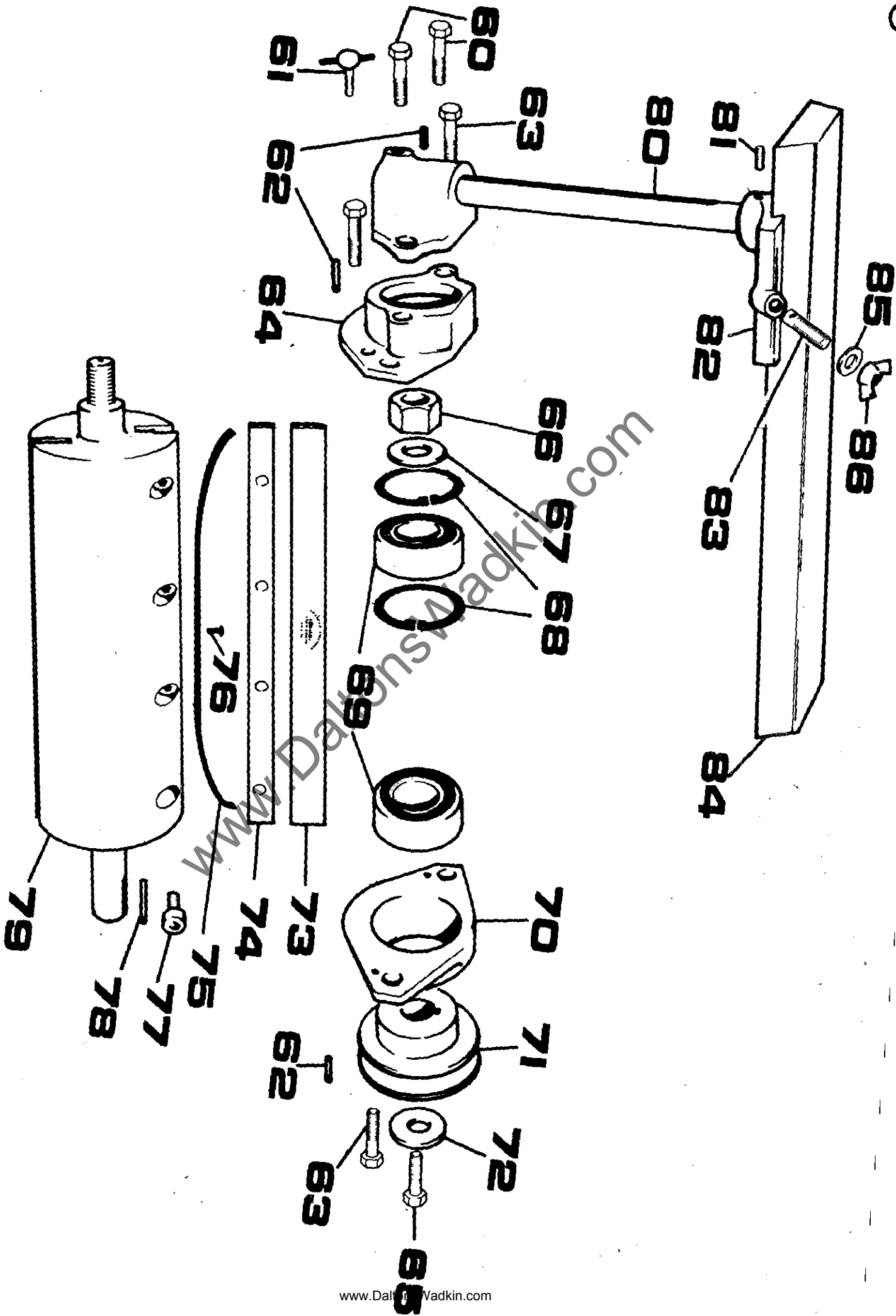

FENCE ASSEMBLY

REF NO.	PART NO.	QTY.	DESCRIPTION
90.	C1036-11.	1	FRONT FENCE PLATE.
91.	A1029-40	1	ADJUSTABLE FENCE INSERT PLATE.
92.		1	M6 X 25MM LONG STUD.
93.		1	M6 WASHER.
94.		1	M6 WINGNUT.
95.		2	$\frac{1}{4}$ " X $\frac{3}{4}$ " DOWELS.
96.		3	$\frac{5}{16}$ " WHIT X $\frac{3}{4}$ " LONG ALLEN SCREWS.
97.	C1029-66	1	FRONT FENCE PLATE BRACKET.
98.		2	$\frac{3}{8}$ " EXTERNAL CIRCLIPS.
99.	A1002-67	1	LOCKING LINK PIVOT.
100.		1	$\frac{1}{4}$ " WHIT X $\frac{1}{4}$ " LONG ALLEN GRUB SCREW.
101.	6686/14	1	$1\frac{3}{4}$ " DIA X $\frac{3}{8}$ " WHIT BLIND HANDWHEEL.
102.		1	$\frac{3}{8}$ " WASHER.
103.	A1029-39	1	FENCE LOCK LINK AND PIVOT BUSH.
104.	A1029-33	1	PLAIN FENCE LINK.
105.		3	$\frac{1}{4}$ " WHIT NUTS.
106.	A1029-36	1	FENCE PIVOT BAR (TOP).
107.	A1029-37	1	" " " (BOTTOM)
108.		4	$\frac{3}{16}$ " X $1\frac{1}{4}$ " GROOVELOK DOWELS.
109.	A1029-76	1	ANGLE POINTER.
110.	B1029-34	1	FENCE LINK WITH HANDLE
111.		1	$\frac{1}{4}$ " WHIT X $\frac{1}{2}$ " LONG ALLEN GRUB SCREW.
112.		3	$\frac{1}{4}$ " WHIT X $\frac{3}{4}$ " LONG HEXAGON BOLTS.
113.		1	$\frac{3}{8}$ " WHIT X $\frac{3}{4}$ " LONG " "
114.		1	$\frac{1}{4}$ " DIA X $\frac{1}{2}$ " DOWEL.
115.	A1792-67	1	FENCE LOCKING WASHER.
116.	A1029-42	1	FENCE RACK BAR.
117.	A1029-29	1	BACK CUTTERBLOCK GUARD SUPPORT SHAFT.
118.		2	$\frac{3}{16}$ " WHIT X $\frac{3}{8}$ " LONG COUNTER SUNK SCREWS.
119.	B1075-38	1	ANGLE INDICATOR PLATE.
120.	A1029-44	1	BOSS FOR ANGLE INDICATOR PLATE.
121.		2	$\frac{1}{4}$ " WHIT X $\frac{1}{2}$ " LONG ROUND HEAD SCREWS.
122.		2	$\frac{1}{4}$ " WASHERS.
123.	B1029-35	1	BACK CUTTERBLOCK GUARD BRACKET.
124.	A1029-28	1	BACK CUTTERBLOCK GUARD.
125.	6686/60	1	$2\frac{1}{8}$ " DIA 8MM PLAIN BORE HANDWHEEL.
126.	A1075-100	1	RIP FENCE PINION WITH 8MM I/D X 14MM O/D X 20MM BUSH.
127.	B1075-11	1	FENCE BAR BRACKET.
128.	A1075-52	1	FENCE LOCKING STUD.
129.	6686/19	1	$1\frac{3}{4}$ " DIA M10 BLIND HANDWHEEL.
130.	D1075-10	1	FENCE ADJUSTMENT BRACKET.
131.	A1075-25	1	SIMPLEX BUSH FOR FENCE BRACKET.
132.		4	M8 X 20MM LONG ALLEN SCREWS.
133.		1	M8 X 45MM LONG " "
134	D1029-31	1	FENCE CANTING BRACKET.



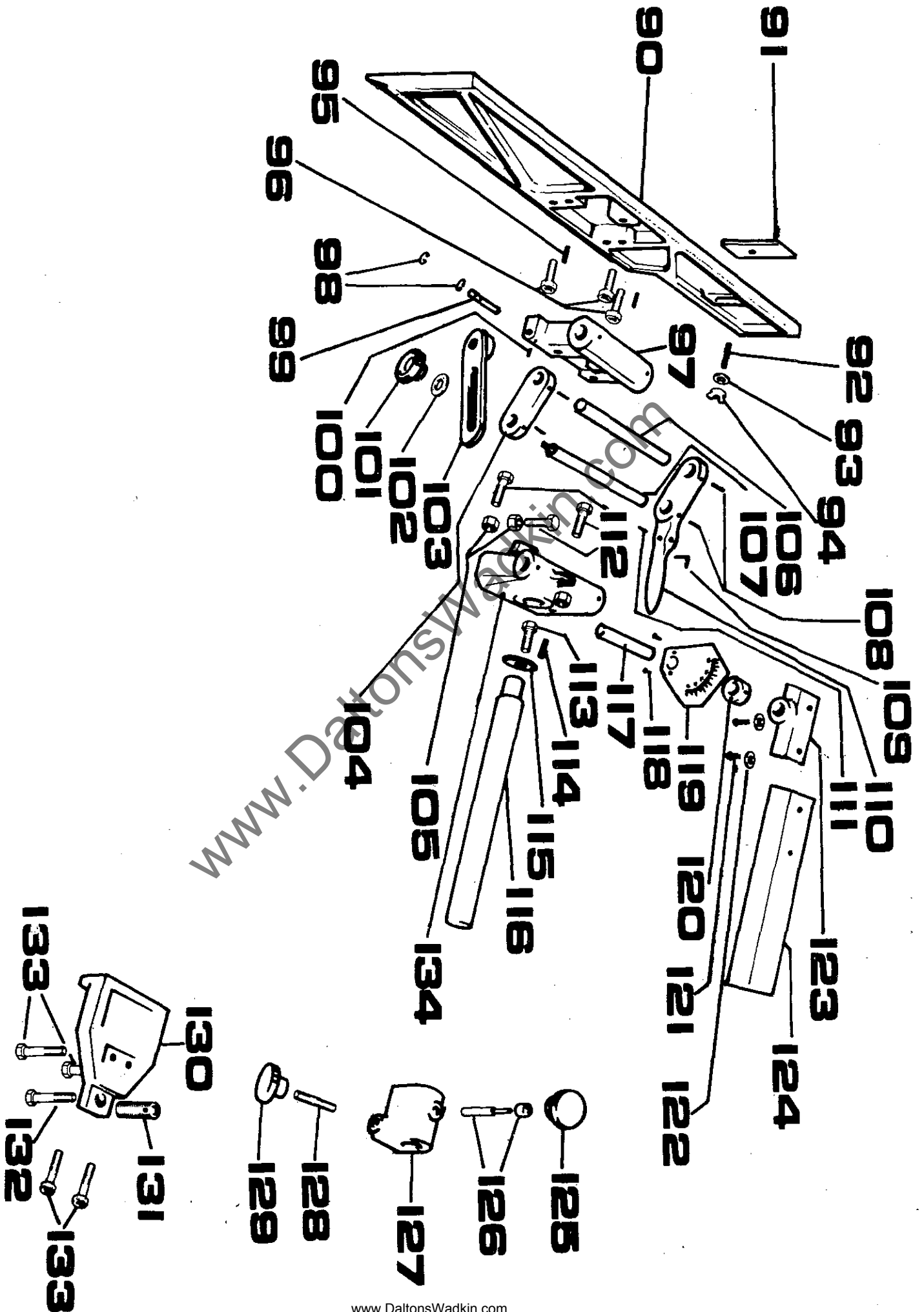

REBATE TABLE(EXTRA)

REF NO.	PART NO.	QTY.	DESCRIPTION
140.	D1029-70	1	BOOMERANG GUARD.
141.	C1029-25	1	REBATE TABLE.
142.		1	$\frac{1}{4}$ " WHIT X $\frac{1}{2}$ " LONG ALLEN GRUB SCREW.
143.	A1075-58	1	SWIVEL PIN FOR BOOMERANG GUARD.
144.		2	M8 NUTS.
145.	A1075-104	1	SPRING ADJUSTER BOLT FOR BOOMERANG GUARD.
146.		1	M8 X 20MM LONG ALLEN SCREW.
147.		2	M8 X 50MM LONG " "
148.	A1075-106	1	RETURN SPRING FOR BOOMERANG GUARD.
149.	A1075-57	1	BRACKET FOR BOOMERANG GUARD.
150.	A1075-105	1	SPRING ANCHOR FOR BOOMERANG GUARD.
151.		2	M6 LOCKNUTS.
152.		2	M10 X 20MM LONG ALLEN SCREWS.
153.		2	M6 X 60MM LONG " "
154.	A1075-69	1	RISE AND FALL RULE BLOCK (USE ON REBATE TABLE ONLY).
155.	A1075-71	1	RISE AND FALL POINTER (LONG) (USE ON REBATE TABLE ONLY).
156.		2	$\frac{1}{8}$ " WHIT X $\frac{1}{4}$ " LONG ROUND HEAD SCREWS.

www.DaltonsWadkin.com

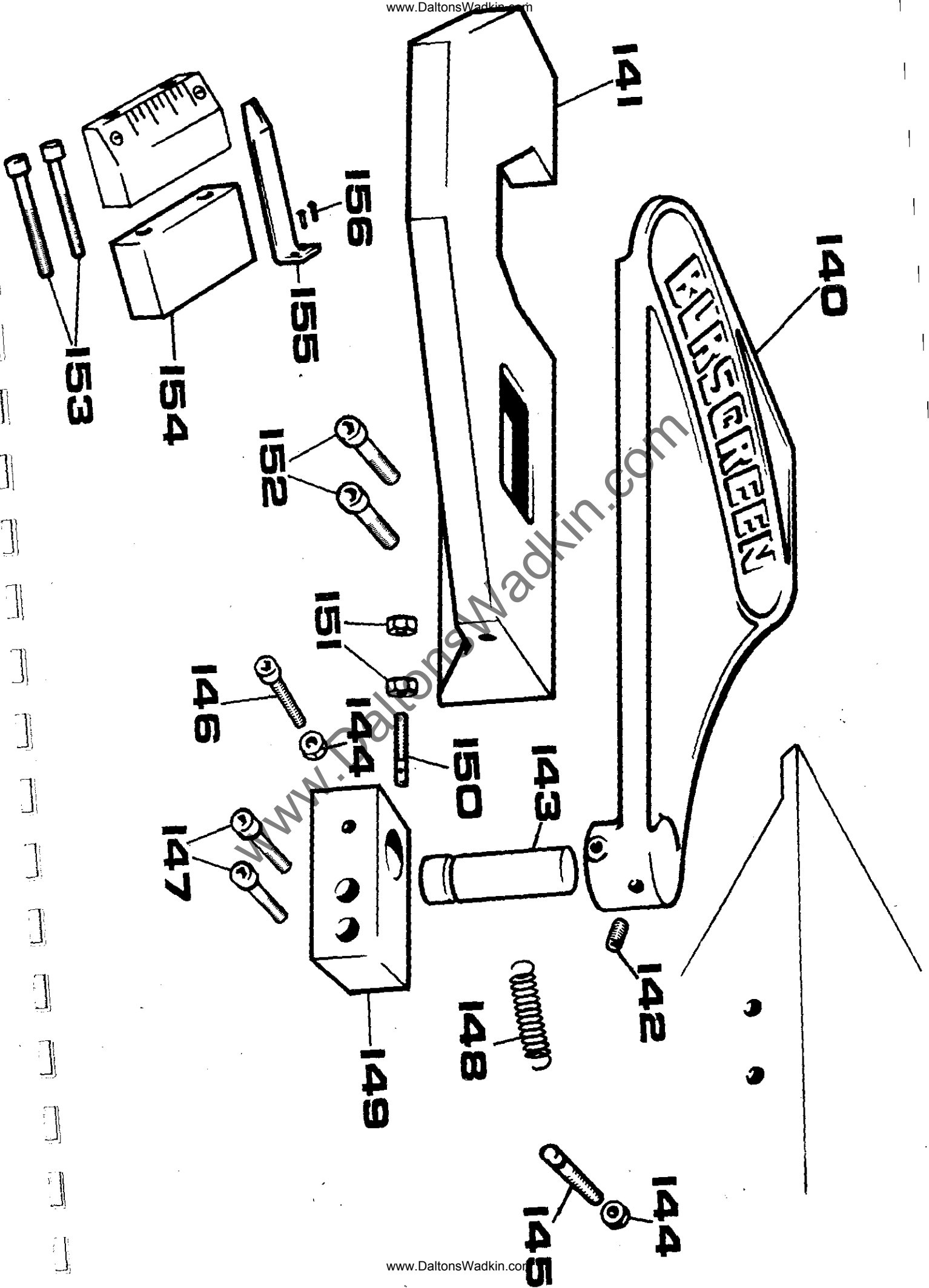

# SHAW GUARD - EXTRA-

REF NO.	PART NO.	QTY.	DESCRIPTION
160.	A1075-94	1	SHAW GUARD TOP PRESSURE BAR.
161.	B-S-I-B	3	$\frac{3}{8}$ " WHIT BALL HANDLE.
162.	B1792-65	1	PRESSURE BAR FILBOE.
163.	A1075-98	1	SHAW GUARD BRACKET.
164.		2	M8 X 35MM LONG COUNTERSUNK SCREWS.
165.	D1792-45	2	SPRING FOR SHAW GUARD.
166.		2	5/16" WHIT X $\frac{3}{4}$ " LONG HEXAGON BOLTS.
167.	D1792-44	2	WOOD SHOE FOR SHAW GUARD.
168.		2	5/16" WASHERS.
169.	A1039-14	1	FRONT PRESSURE FILBOE FOR SHAW GUARD.
170.		4	NO. 10 X $\frac{3}{4}$ " LONG WOODSCREWS.
171.	A1075-95	1	SHAW GUARD CANTILEVER.

<b>IMPORTANT NOTE</b>	:- WHEN USEING REBATE TABLE FEATURE IT IS COMPULSORY TO USE A SHAW GUARD. (FULL FIXING DETAILS SHOWN) (APPLIES TO UNITED KINGDOM ONLY).
---------------------------	-----------------------------------------------------------------------------------------------------------------------------------------

www.DaltonsWadkin.com

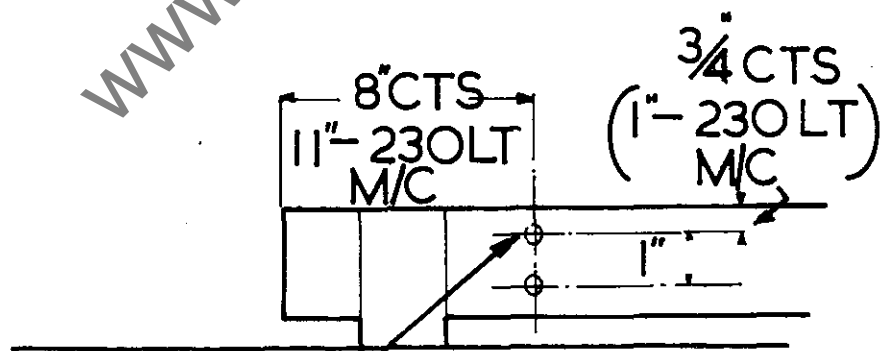
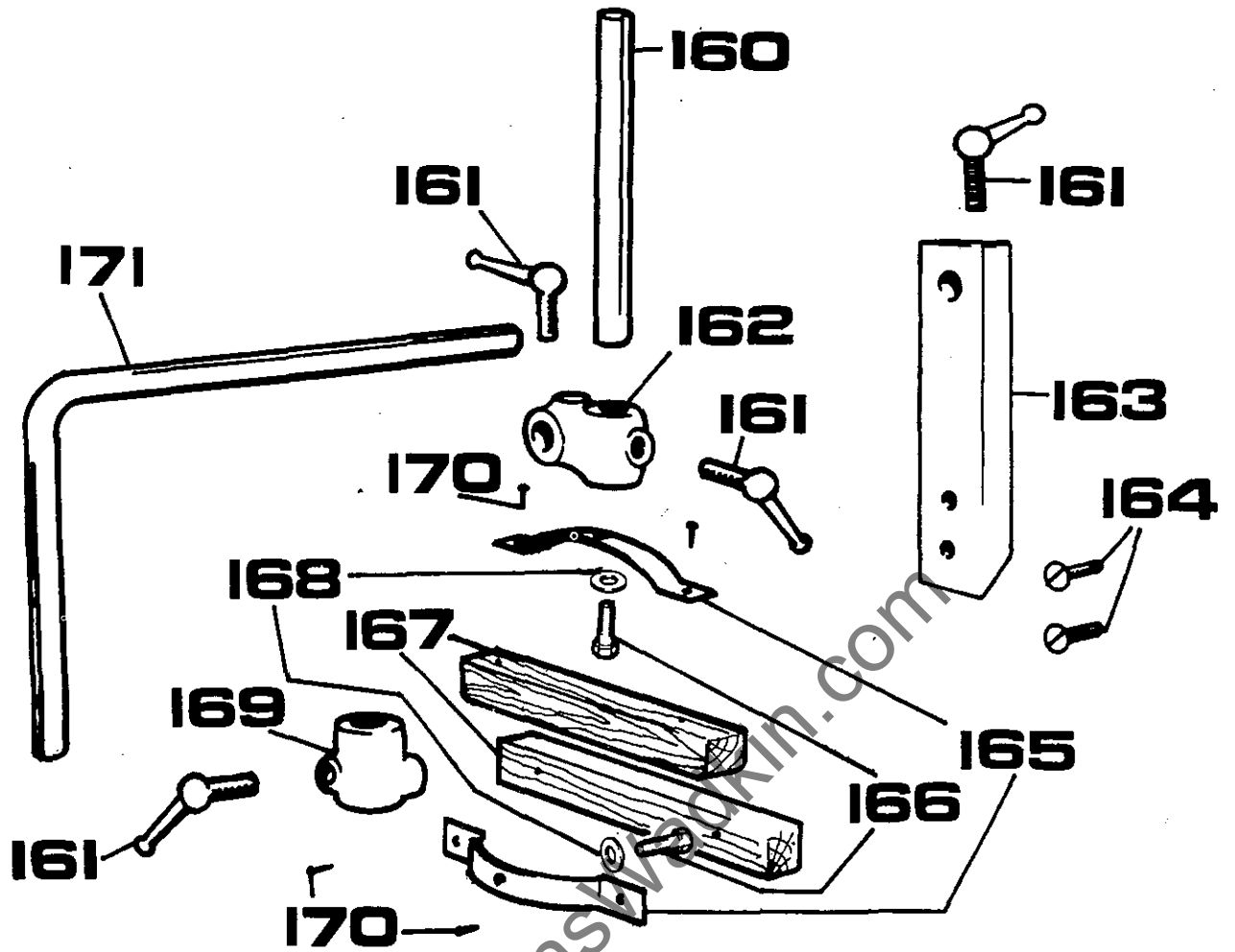

2 - 11/32" DRILL & C/SINK  
FENCE FIXING POSITION FOR  
SHAW GUARD

# KNIFE SETTING DEVICE

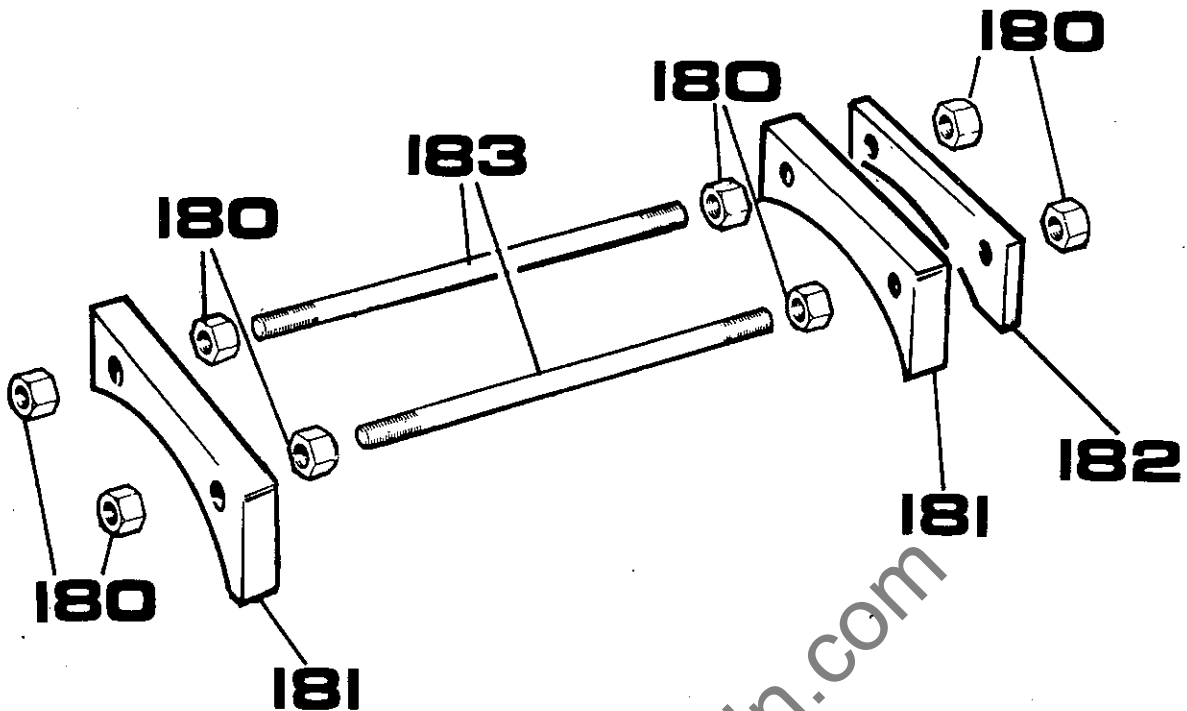

REF NO.	PART NO.	QTY.	DESCRIPTION
180.		8	M8 NUTS.
181.	A1075-31	2	KNIFE SETTING DEVICE ENDPLATES.
182.	A1075-32	1	" " " STOP PLATE.
183.	A1075-33	2	" " " TIE BARS.

## RECOMMENDED SPARE PARTS.

PART	QTY	REF
CUTTERBLOCK BEARINGS	2	SKF 6205 - 2RS
TABLE RISE AND FALL SCREW RACES	2	SKF 51102
DRIVE BELT	1	ALPHA 400 SPZ 1010
PLANER BLADES	SET OF 2 OR 3	BVP 37
ELECTRICAL SPARES FOR M.E.M. ADS STANDARD STARTER 380/440 - 3 PHASE - 50 CYCLES	1 SET	MEM ADS
FIXED AND MOVING CONTACTS	1	" "
NO VOLT COIL	1	" "
OVERLOAD HEATER	1 SET	" "
FOR ANY OTHER TYPE OF STARTER OR SUPPLY PLEASE APPLY DIRECT TO BURSGREEN COLNE LTD GIVING FULL DETAILS OF VOLTAGE AND STARTER MAKE AND REFERENCE		