

www.DaltonsWadkin.com

"WADKIN" DIMENSION SAW

TYPE "PP"

INSTRUCTION BOOK NO: 987

Wadkin

DIMENSION SAW TYPE P.P. PRINCIPAL DIMENSIONS AND CAPACITIES :-

Standard size of saw	18"	450 mm.
Maximum depth of cut	5½"	140 mm.
Depth of cut with saw canted to 45°	3. 7/8"	100 mm.
Throat opening between fixed and sliding tables	6"	150 mm.
Saw cants up to	45°	45°
Maximum distance between saw and ripping fence on standard table	30"	760 mm.
Will crosscut on standard table with saw at 90°	5½" x 29½"	140 x 750 mm.
	1" x 36"	25 x 915 mm.
Length cut off using stop on mitre fence	36"	915 mm.
Ripping fence cants up to	45°	45°
Horse power of motor.. .. .	5	5
Speed of saw spindle 50 and 60 cycles	2800 r.p.m.	2800 r.p.m.

Details included with the machine.

One pair saw collars and nut.
 Motor and control gear.
 Saw guard and riving knife.
 Single mitre fence with stop bar and stop.

Canting Ripping fence.
 Set of spanners.
 Tin of lubricant.

FIG. 1.

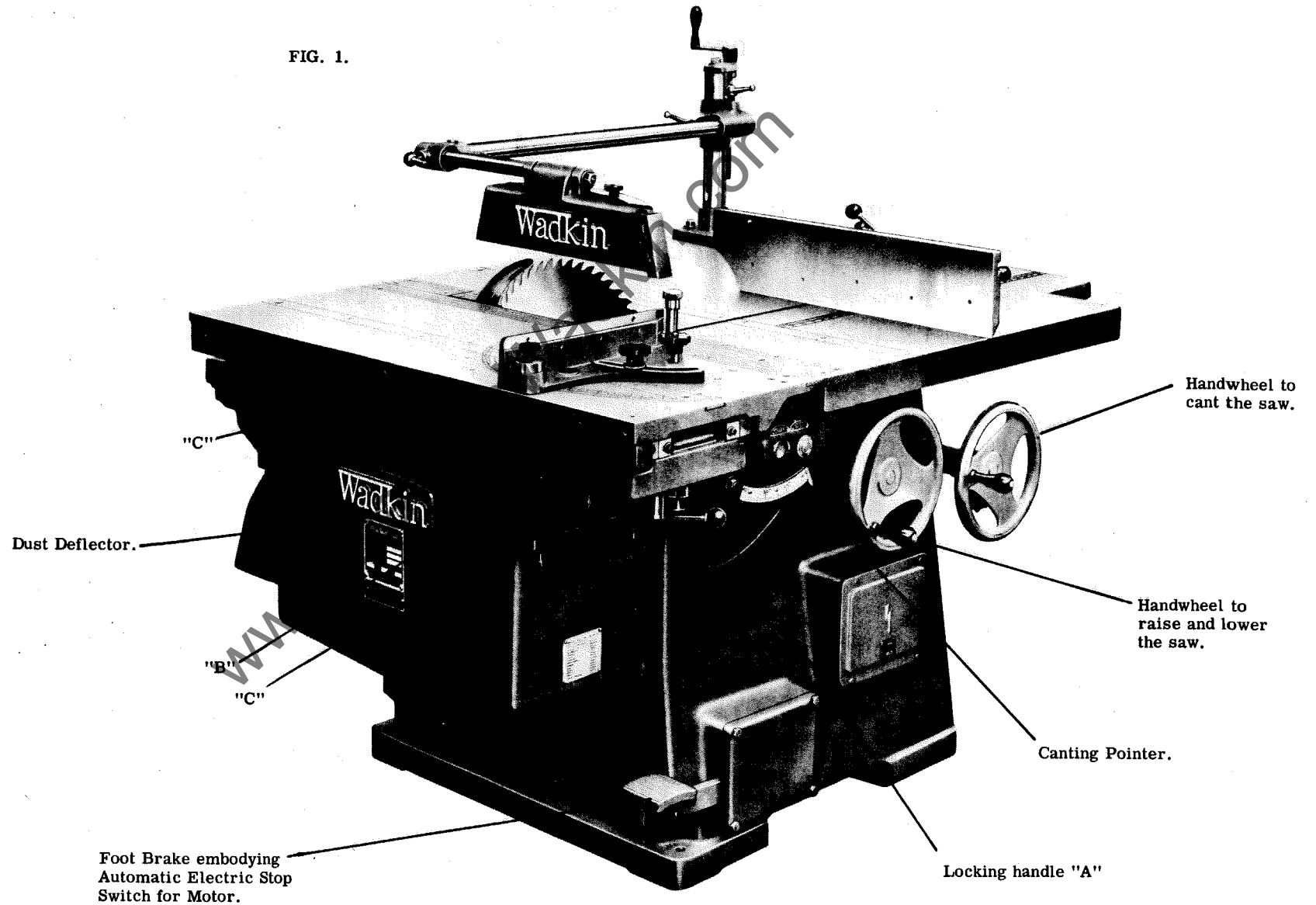
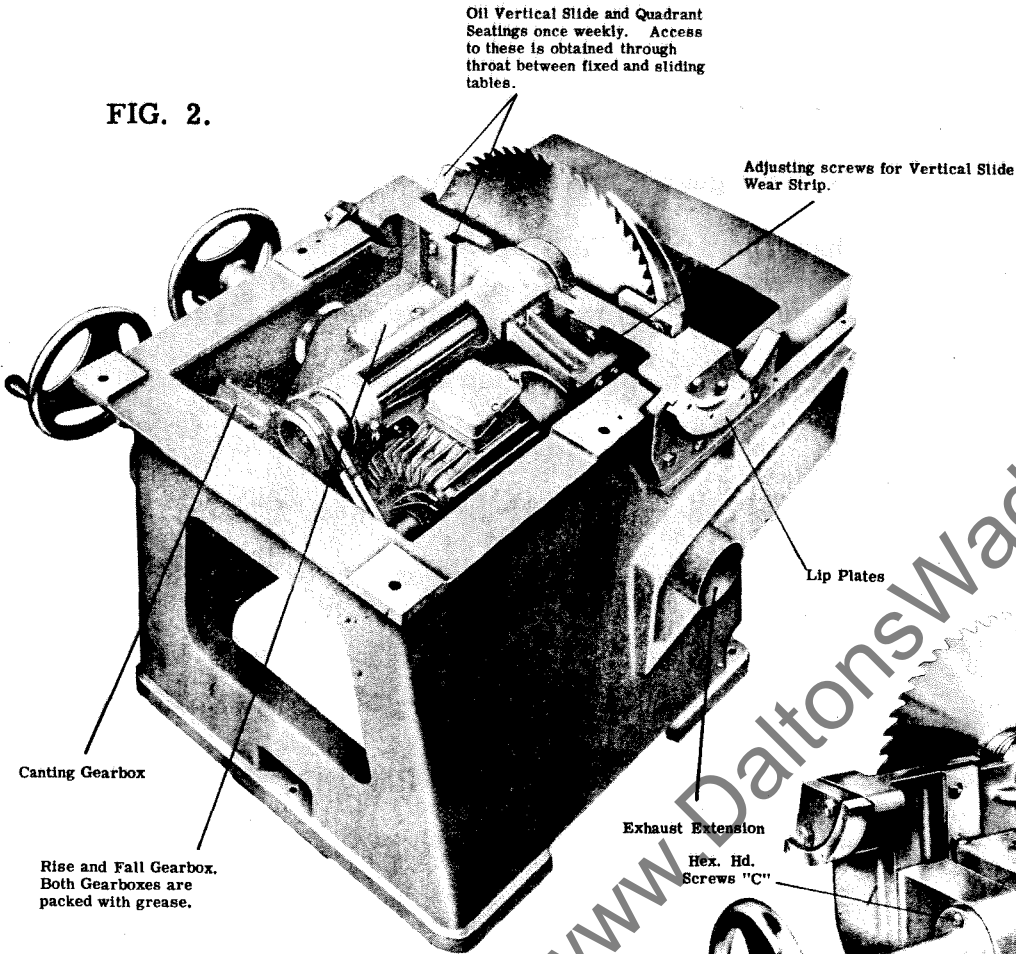

FIG. 2.



Oil Vertical Slide and Quadrant Seatings once weekly. Access to these is obtained through throat between fixed and sliding tables.

Adjusting screws for Vertical Slide Wear Strip.

Lip Plates

Canting Gearbox

Rise and Fall Gearbox. Both Gearboxes are packed with grease.

Exhaust Extension

Hex. Hd. Screws "C"

Lock for Rise & Fall of Saw. Identical to lock for canting motion.

Dead Stop for Canting Motion. This should not be touched. Machine is set initially with saw at 90°.

Canting Nut

www.DaltonsWadkin.com

FIG. 3.

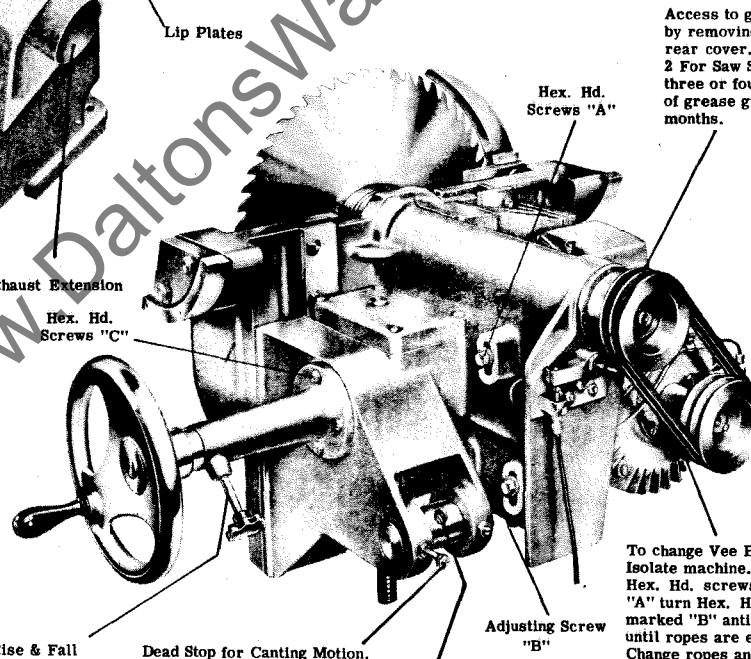

Access to grease nipples by removing main frame rear cover. 2 For Motor 2 For Saw Spindle. Give three or four depressions of grease gun every three months.

Hex. Hd. Screws "A"

To change Vee Belts. Isolate machine. Slacken Hex. Hd. screws marked "A" turn Hex. Hd. screw marked "B" anti-clockwise until ropes are easily removed. Change ropes and retension. Lock Hex. Hd. screws marked "A". Spare Vee Ropes No. A28.

Adjusting Screw "B"

REMOVAL OF SAW SPINDLE CARRIAGE.

Isolate machine electrically. Remove guard and fence assemblies. Remove complete sliding table unit by removing locking handles marked "A" Fig. 1 and lifting table clear of tenon marked "B" Fig. 1 and brackets marked "C" Fig. 1. Remove tee slot filling in strips from main table and knock through two dowel pins from the top and remove four hexagon head screws from underside of body flange, lift table clear. Remove electrical leads to motor and brake cable from brake shoe. Remove four hexagon head screws marked "C" Fig. 3 from each arm carrying handwheel these can now be withdrawn from both gearboxes. Wedge saw spindle carriage in 90 degrees position using wood blocks, then remove canting gearbox pivot pin, gearbox complete with canting screw can now be withdrawn from canting nut see Fig. 3. Remove dust deflector and exhaust extension, canting pointer from lip plate and remove lip plates see Fig. 2. Spindle carriage can now be removed from its position in the main frame. Reassemble in the reverse order of the above.

Maintenance that can be carried out with saw spindle carriage removed.

Changing of motor.

Changing of spindle bearings, see special instructions. Page 6.

Adjustment to wear strip of vertical slide.

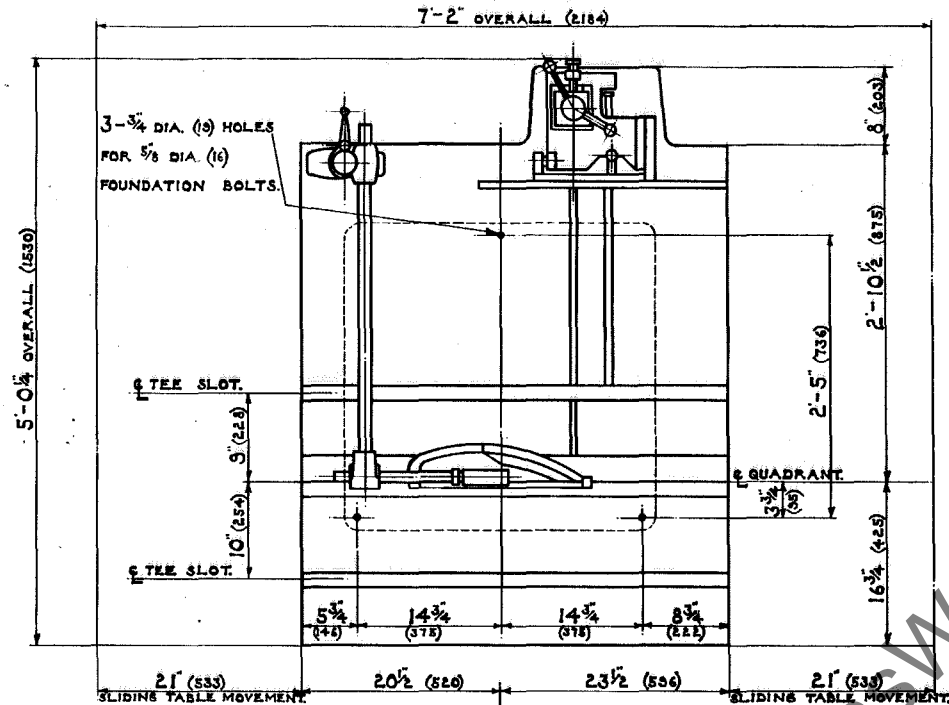

FOUNDATION PLAN
 FIG. 4.

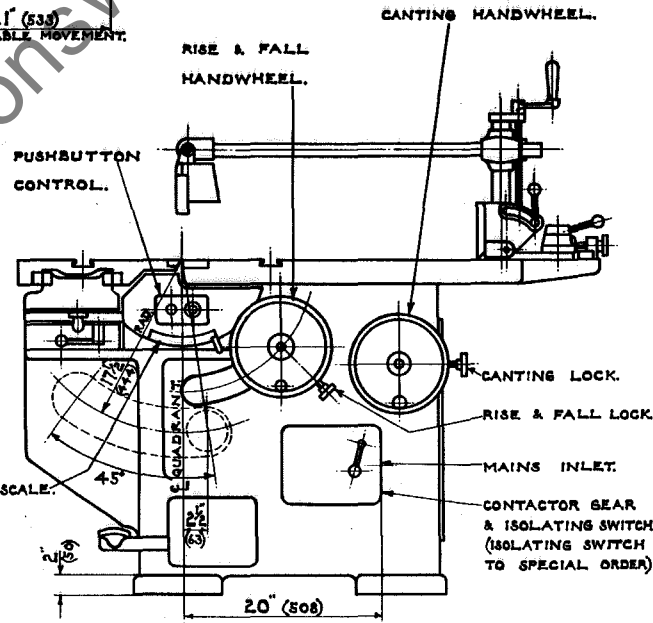
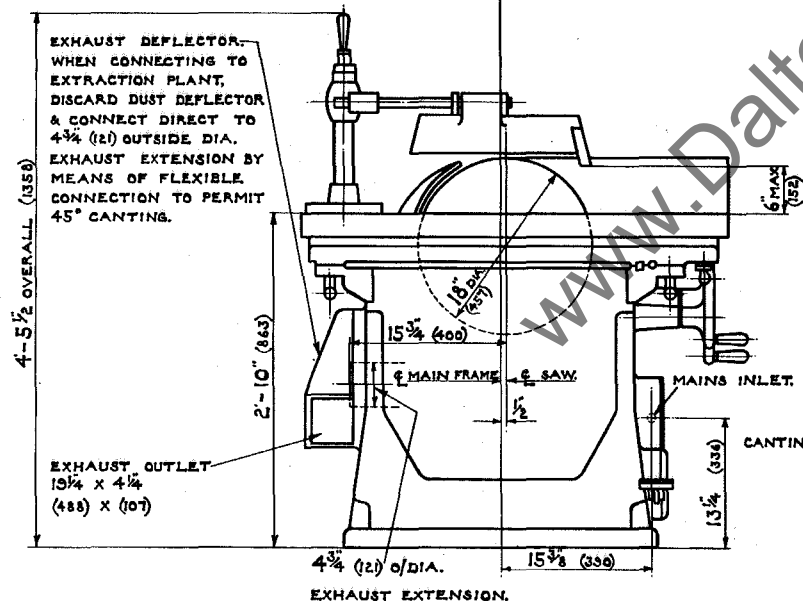

SECTION THROUGH BELT DRIVEN SPINDLE.

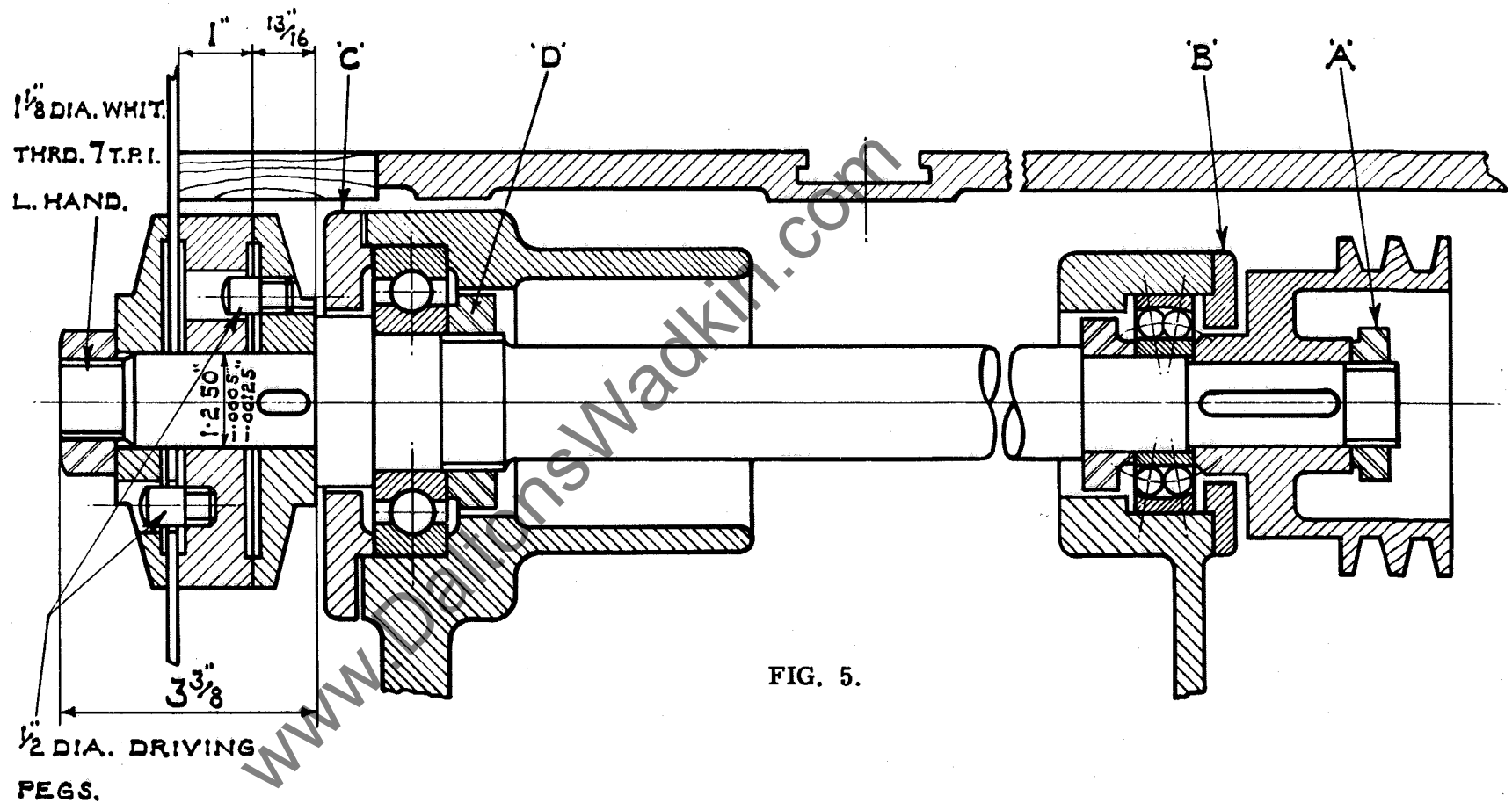

To remove the spindle without removing saw spindle carriage, cant saw to approx. 30°. Remove sliding table (see page 4). Remove vee ropes see Fig. 3. Remove spindle nut, saw & saw flanges. Remove ball bearing locknut marked "A". This has a right hand thread. Remove pulley, end cap marked "B", this has four countersunk head screws, and driving key. Remove end cap marked "C" this has capscrews. Spindle can now be knocked out from rear end using a piece of wood or soft metal (Brass, Copper, Lead).

With the spindle removed rear bearing can be lightly tapped out of its housing. To change front bearing, remove locknut marked "D" this has a right hand thread, and lightly tap off bearing.

To Reassemble.

Before assembly clean out all old lubricant, assemble in the reverse order of the previous mentioned procedure, ensuring that no dirt or grit enters the bearings or housings. Smear the bearings with Wadkin ball bearing grease, grade L. 6. When fitting ball bearings do not hammer the races into position but give gentle taps with a soft rod all round the periphery. The inner race should be a good push-fit on the spindle and the outer race a good sliding-fit.

BALL BEARING LIST

One SKF 6309 Saw spindle front bearing.
One SKF 1306 Saw spindle rear bearing.
Four SKF 08 Two each for rise and fall and canting motions.

Lubrication see Figs. 2 and 3.

The grease lubricant recommended is Wadkin Grade L. 6. Alternative grease,

Shell-Mex & B. P. Ltd.	-	Shell ALVANIA GREASE 3
Mobil Oil Co.	-	MOBILUX GREASE No. 2
Castrol	-	SPHEEROL S

For oil lubrication, use Wadkin Grade L. 4. Alternatively

Shell Mex & B. P. Ltd.	-	Shell VITREA OIL 33
Mobil Oil Co.	-	Mobil VACTRA OIL (heavy medium)
Castrol	-	PERFECTO. NN.

THOROUGHLY CLEAN DOWN MACHINE WEEKLY.

FOOT OPERATED BRAKE ADJUSTMENT

Grubscrew marked "A" Fig. 6 is initially set to depress micro-switch when foot pedal is operated to its full extent. Failure of brake pedal to return will prevent machine being started, check spring for fatigue and replace if necessary.

To replace micro-switch, isolate machine, remove switch, disconnect electrical leads, connect new switch and replace switch on facing. Start machine and ensure that when brake pedal arm is depressed to its full extent the micro-switch is operated by the grubscrew marked "A".

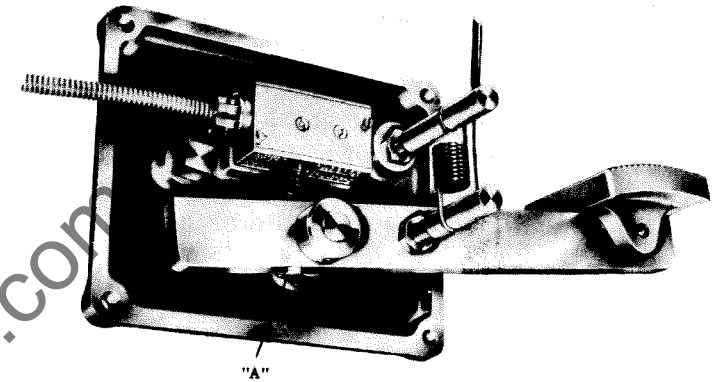

FENCES, TABLE AND GUARDS.

To set canting ripping fence for cutting. Move fence to approximate position required. Operate first lock by rotating clockwise, fine adjust to obtain correct dimension required. Operate secondary lock, this also squares fence to dovetail groove. To unlock fence operate first lock in anti-clockwise direction until dead stop is reached, secondary lock need not be operated.

CANTING RIPPING FENCE LOCKING ADJUSTMENT

Should the fence secondary lock not operate the two hexagon head screws (on the right hand side of the fence base) should be slackened off and the three grubscrews rotated clockwise each by the same amount until the eccentric secondary lock holds the fence in the required position after operating the first lock.

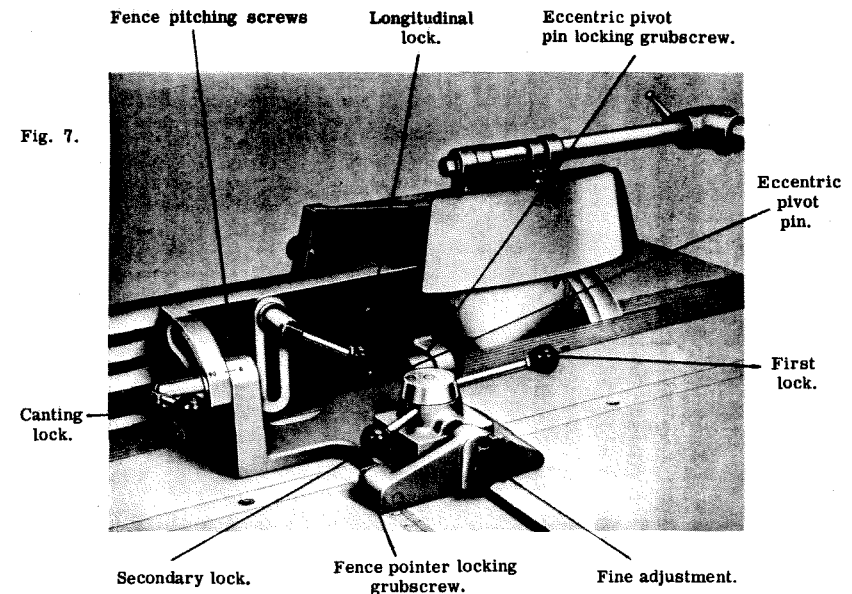

The ripping fence is initially pitched .004" this is measured at the front and rear of the saw, with the saw fully raised. The dimension at the rear of the saw being .004" greater than at the front of the saw. Should this pitching require altering the grub screw locking the eccentric pivot pin, should be slackened off and the eccentric pivot pin turned so as to increase or decrease the pitching.

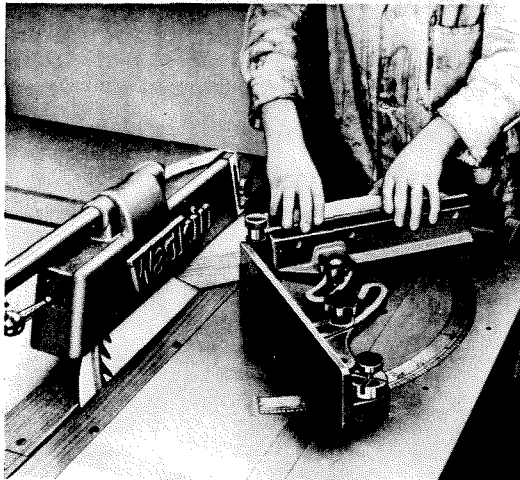

Fig. 8.

To adjust the fence pointer measure dimension between set of saw nearest fence and fence plate, then slacken off pointer locking grub screw, set pointer to dimension obtained between saw set and fence, lock pointer in position.

DOUBLE MITRE FENCE. Fig. 8. is in two parts both made to pivot from a central pin fixed in sliding table. Degree angles are marked on the table for accurately setting the fences, the principal angles being positively located by spring plunger. Mitres can be cut giving accurately squared frames when assembled a bar and stop determines the exact length of material cut off. Front leaf is supplied as standard, rear leaf optional extra.



Fig. 9.

Cross cutting fence Fig. 9. is used for both square and angular work and can be used either side of the saw in the table grooves. A bar and stop determines exact length of material cut off. This fence is an optional extra.

FIG. 10 STANDARD MACHINE TABLE

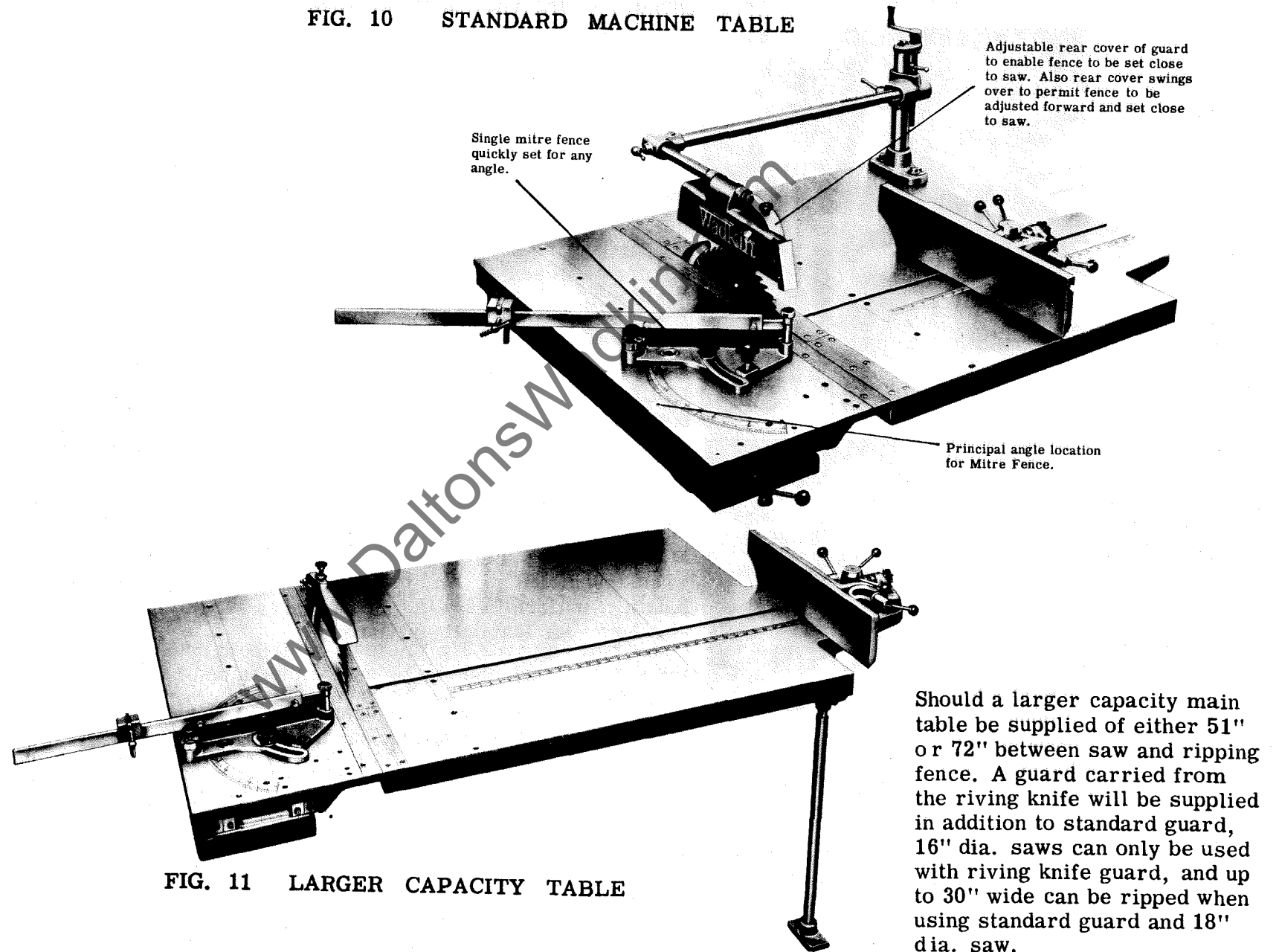

FIG. 11 LARGER CAPACITY TABLE

SLIDING TABLE ASSEMBLY

Lock handles marked "E" fig.6. With rails carrying linear bearings in position, and hexagon head screws holding adjustable rail finger tight, lower table on to intermediate slide and insert four pieces of $\frac{3}{8}$ " diameter steel, two each end, and adjust hexagon hole grubscrew at each end of table to trap $\frac{3}{8}$ " diameter rods in position as shown in fig. 1.

Insert wooden wedges at one end of table only and remove $\frac{3}{8}$ " diameter rods at this end as shown in fig. 2.

Enter two-thirds of the steel bridge between table and intermediate slide as shown in fig. 3.

Nylon cages and $\frac{3}{8}$ " diameter steel balls can now be inserted by holding each ball in nylon cage with one finger of each hand and feeding into slide-way as shown in fig. 4.

With bridge piece complete with nylon cages in position, remove wooden wedges and $\frac{3}{8}$ " diameter rods and place in position end retaining plates at each end of slide-way.

Traverse table to its full extent in one direction, fig. 5, and using an allen key adjust slide with screws marked "A" fig.6 until table moves freely in this position. Now traverse table to its full extent in the opposite direction and repeat adjustment with screws marked "C". Centralise table and adjust slide with screws marked "B". With table traversed to its full extent check for slackness in the slide in both directions and if necessary re-adjust to eliminate. Check sliding table for alignment with main table by traversing table to its full extent and checking with straight edge across main and sliding tables; repeat this operation at the opposite end. Should sliding table need re-aligning with main table, first remove dowel pins in brackets marked "D", slacken hexagon head screws and adjust table in required direction as shown in fig. 6.

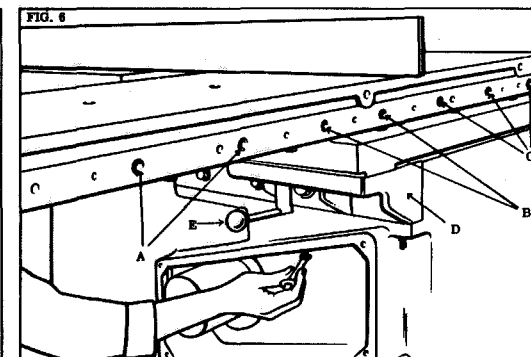
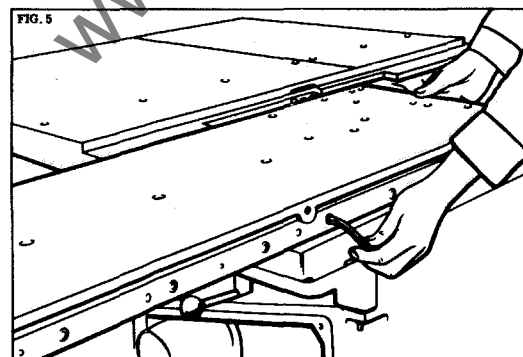
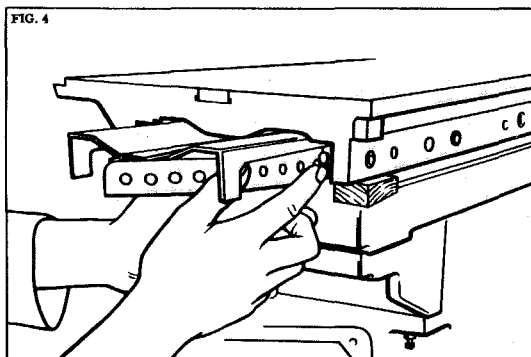
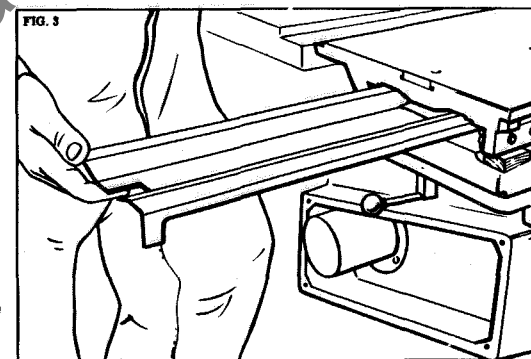
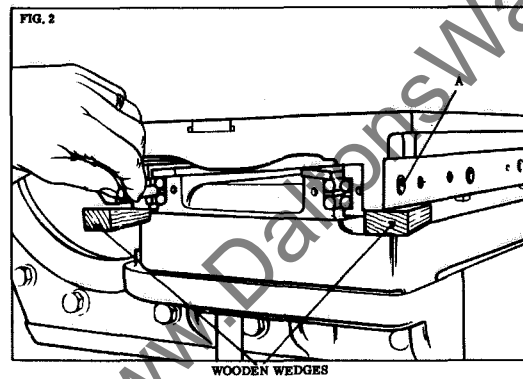
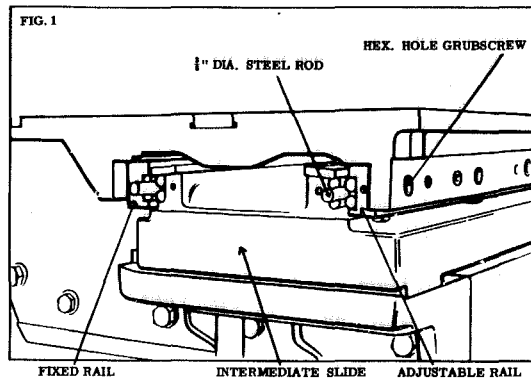



18" RIPPING SAW FOR GENERAL WORK. PART No QS10.



16" FLAT CROSS CUT QS8
 16" HOLLOW GROUND QS9
 18" HOLLOW GROUND QS12
 18" FLAT CROSS CUT SAW QS11



14" HOLLOW GROUND SAW QS33
 for cutting Bakelite, Tufnol and similar materials.
 18" NOVELTY TYPE SAW QS84
 for cutting Plywood.

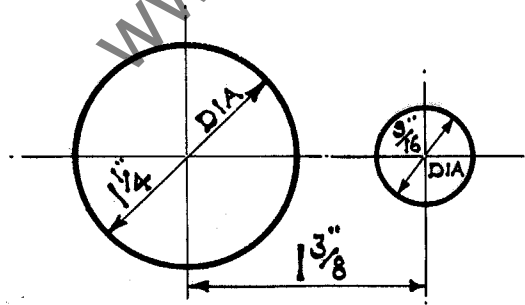

SPINDLE AND PIN HOLES IN SAWS.

SAWS FOR USE ON

THE P.P. TYPE DIMENSION SAW

The saws illustrated are specially manufactured and tensioned to run at high speed: it is therefore recommended they are obtained from us. The teeth are designed to give the best possible finish to the work.

Always keep the teeth sharp with an even set on both sides. Before putting a new saw to use it must be ranged down when running at normal speed and each tooth brought to a sharp cutting edge.

TUNGSTEN CARBIDE TIPPED SAWS

14" TUNGSTEN CARBIDE TIPPED QS174
 for cutting Plywood, Hardwood & Asbestos.

14" NOVELTY TUNGSTEN CARBIDE TIPPED QS176
 for cutting Plastics and Plywood.

16" TUNGSTEN CARBIDE TIPPED QS175
 for cutting Hardwoods and Plywood.

TWO-KNIFE WEDGE TYPE CIRCULAR CUTTERBLOCK, PLAIN BORE, Q. R. TYPE.

8" dia. x 15/16" thick x 1 1/4" bore, Part No. QR.16.

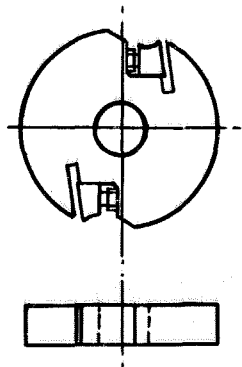

These cutterblocks are designed to take 5/32" upto 1/4" thick cutters: this permits tungsten carbide tipped cutters to be supplied when necessary.

The cutters can be used for mouldings requiring not more than 1/2" cutter projection when using 1/4" thick cutters.

Our standard VZ range of cutters can be used in these cutterblocks, also existing Whitehill head cutters. See Section D Tools Catalogue.

4. 1/16" SQUARE 1 1/4" BORE DOVETAIL CUTTER-BLOCKS. 2" LONG.

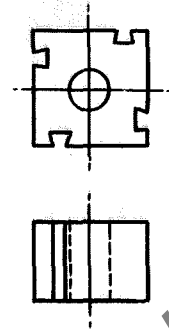

These cutterblocks are used for longer runs, cutters working in pairs, several pairs may be mounted on a single block to build up mould. The cutters on these cutterblocks have a very good cutting angle. They are 3/8" thick and are securely held by dovetail bolts. It is therefore possible to have a large overhang allowing deep moulds to be worked with safety.

A limited range of Tungsten Carbide Tipped cutters are available. Shaped cutters can be provided to special order.

For standard cutters see Section C of our Tools and Sundries Catalogue.

HIGH SPEED STEEL INSERTED TOOTH GROOVING SAWS.

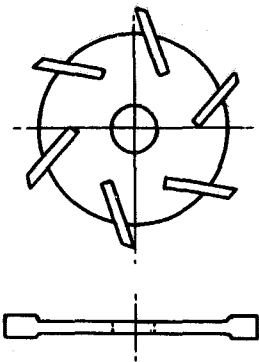

When enquiring please give width and maximum depth of cut required. These saws are used for accurate high grade work. They are fairly expensive and require good handling. They are available in sizes from 10" to 12" diameter, and in varying widths on cut.

See Section A Tools Catalogue

HEAVY TYPE WOBBLE SAW UNIT ON SCREWED SLEEVE

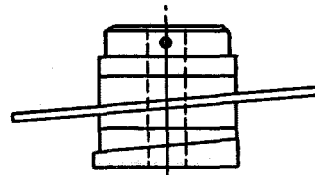

Once set, the saw and collars remain tightly locked on sleeve. This type may be set and kept at its setting when not on machine. It is a self-contained unit. A special spindle locknut is supplied with this unit.

12" Diam. 1/8" to 2 1/8" grooves

See Section A Tools Catalogue

EXPANDING GROOVING SAWS OR DADO HEADS

12" Diameter

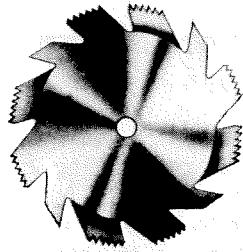

Outside Cutter



Inside Cutter

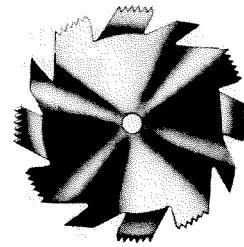

Outside Cutter

within the range of the set, measured in eighths or sixteenths of an inch, can be cut.

- No. 1. For grooves $\frac{1}{8}$ " to $\frac{3}{8}$ " wide, rising by $\frac{1}{8}$ ths.
- No. 2. For grooves $\frac{1}{8}$ " to $\frac{5}{8}$ " wide, rising by $\frac{1}{8}$ ths.
- No. 3. For grooves $\frac{1}{8}$ " to $\frac{3}{4}$ " wide, rising by 1/16ths.
- No. 4. For grooves $\frac{1}{8}$ " to 1" wide, rising by 1/16ths.

This tool is recommended for giving a smooth finish, both with and across the grain in hard or soft woods. It is made up in sets and each set consists of two outside cutters, $\frac{1}{8}$ " thick, and several inside cutters of various thicknesses, $\frac{1}{16}$ ", $\frac{1}{8}$ " or $\frac{1}{4}$ " thick, so that by adding to or taking away, any width of groove

EXPANDING TRENCHING AND GROOVING HEADS

This type is expandable and made in two sizes 13" diameter. Accurate spacing collars give the desired width of cut rising by 1/16" up to the maximum. It is arranged to give a shearing cut and provided with side or spur cutters to produce clean cutting. The head is mounted on a loose sleeve and locked tight by a fine thread nut. One sleeve only is required for the two sizes of head.

Sleeve for either head P. P. 135 complete with special spindle nut.

- J. P. 550 for grooves $\frac{1}{2}$ " to 1" wide and $1\frac{1}{2}$ " deep
- J. P. 558 for grooves $1\frac{1}{16}$ " to 2" wide and $1\frac{3}{4}$ " deep

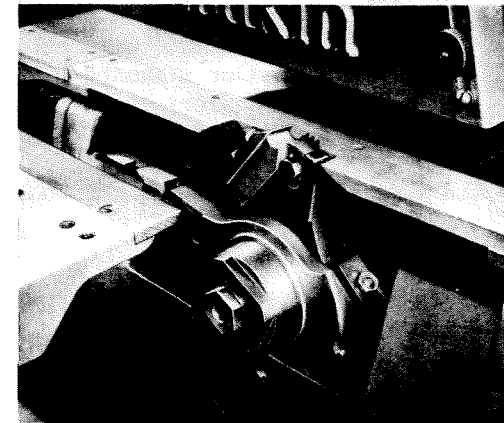

To minimise the throat between fixed and sliding tables, both spacing collar and rear saw collar are removed from the spindle, this permits the trenching or grooving head to be set back into the main table as shown in the accompanying photograph.

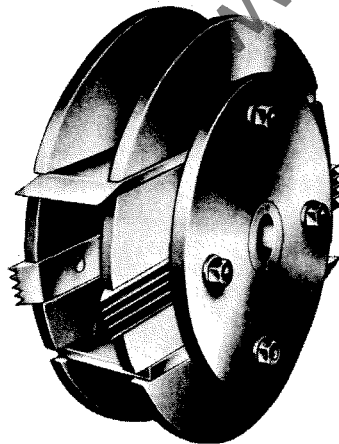

The head illustrated opposite can be used with equal facility but is not capable of such fine adjustment for width of groove as the one shown above. The width of cut is varied by changing the cutters. Side or spur cutters in addition to the grooving cutters effect clean cutting.

Head J. P. 215 is 11" diameter and will groove $\frac{3}{4}$ " to 2" wide 1" deep.

ELECTRICAL INSTALLATION INSTRUCTIONS

The cabling between the motor and the control gear has been carried out by Wadkin Ltd. , and it is only necessary to bring the line leads to the machine for it to be put into service. This should be done as follows :

1. Fit triple pole isolating switch near the machine unless it has been supplied to special order by Wadkin Ltd. , when it will be fitted and connected to the machine.
2. Connect the line lead to the appropriate terminals. See diagram of connections. The cables should be taken to the machine in conduit and secured to the control gear by locknuts.
3. Connect solidly to earth.
4. Close isolating switch and press start button. If motor does not rotate in the right direction, interchange any two incoming line leads.

FAILURE TO START

1. Electric supply is not available at the machine.
2. Fuses have blown or have not been fitted.
3. Isolating switch has not been closed.
4. Lock-off or stop button has not been released.
5. Micro switch open, due to foot brake lever depressing switch (see separate foot brake adjustment instructions)

STOPPAGE DURING OPERATION AND FAILURE TO RESTART

1. Fuses have blown.
2. Overloads have tripped. They will reset automatically after a short time and the motor can be restarted in the usual manner.

ADJUSTMENTS

For a finer overload setting, set the load indicator to a lower value and vice-versa for a less fine setting.

GENERAL

Check the earth connection from time to time. Users are recommended to display in an appropriate position in the maintenance department a Wadkin Electrical Maintenance Instruction Card, No. 356, which is issued gratis on application.

D. 1149

DIMENSION SAWBENCH MODEL P.P.

See diagram
D 215b opposite

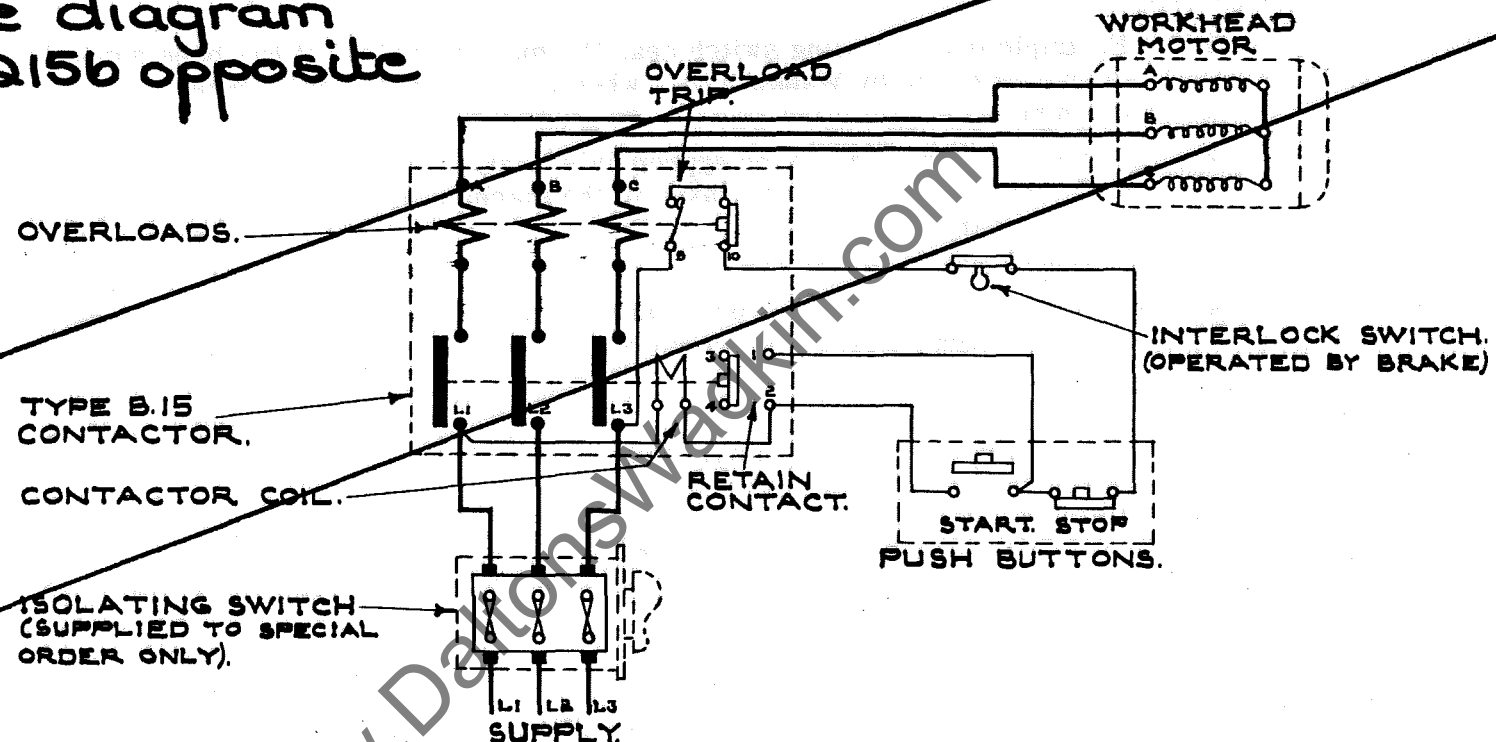
**INSTALLATION INSTRUCTIONS.**

Fit isolating switch near machine so that the electrical gear may readily be isolated for inspection purposes. Bring supply cables to isolating switch and to L1 - L2 - L3 at contactor through conduit which should be screwed into the machine and secured by means of locknuts. Ensure that the direction of rotation is correct before putting the machine into service. To reverse rotation interchange L1 & L3 at contactor.

OPERATING INSTRUCTIONS.

To start machine : close isolating switch and press 'start' button. To stop machine : press 'stop' button. To lock off machine : press and turn 'stop' button, this must be released before a start can be made.

OVERLOAD.

Should the machine stop due to overload, wait for a short time to allow the coils to cool then start in the usual manner. The overloads are set at these Works at 'M' for automatic reset after tripping, if set at 'P' the plunger on the overload assembly should be depressed to reset.

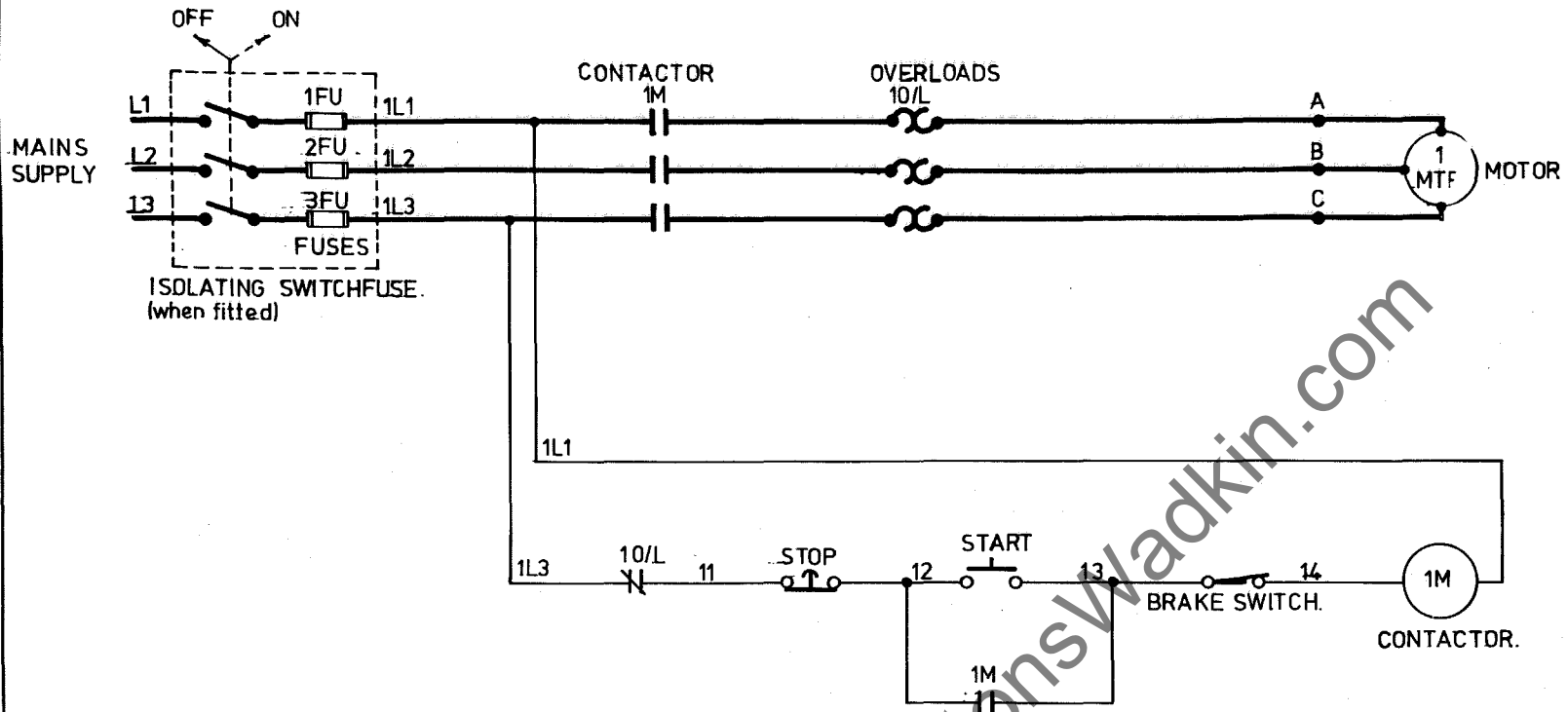

SIMILAR TO

THIRD ANGLE PROJECTION

WADKIN LTD. LEICESTER

SURFACE FINISH
▽ - ROUGH M/C
▽▽ - FINISH M/C
▽▽▽ - ROUGH GRIND
▽▽▽▽ - FINISH GRIND

IMPERIAL LIMITS
FRACTIONS ± 1/32"
DECIMALS ± .005"
METRIC LIMITS
WHOLE NUMBERS = ± 1 M/M
DECIMALS = ± 0.1 M/M
BALL BEARING LIMITS-SEE LIST

DATE	SIG.	D	C	B
ALT. No.				

DATE	A	DESCRIPTION
29.4.77		SINGLE MOTOR CONTROL
REDRN. BY		BRAKING SWITCH
CHKD. BY		DIRECT-ON-LINE STARTING

QTY.	MATERIAL
PART No.	
D.2156	



. . . blow away harmful dust, chips and dirt with a Wadkin Electric Blower

No motor can run at its maximum efficiency with its ventilating duct or control gear covered with dust and dirt. Sooner or later the resultant overheating will cause serious trouble.

Similarly, accumulations of chips and dust, in the mechanical parts of the machine can interfere with its efficiency. A few minutes a week for blowing down all Woodworking Machinery will be amply repaid in better and easier running, in increased life, and freedom from breakdown.

Blowers can be supplied for single phase A.C. or Direct Current for any voltage up to 250.

Please state voltage when ordering.



PARTS BOOKLET

FOR

DIMENSION SAW TYPE PP

www.DaltonsWadkin.com

MACHINE : PP
MACHINE NO: 1407
TEST NO: 68975

PARTS REQUIRED

1 - PP1001/PP9 QUADRANT
1 - PP1001/PP39 SPACING COLLAR
1 - PP1001/PP503 SLIDING TABLE
1 - PP1001/PP546 FENCE
1 - PP1001/PP595 EXHAUST NOZZLE

www.DaltonsWadkin.com

PP1001/PP8	QUADRANT
PP1001/PP9	QUADRANT
PP1001/PP10	LIP PLATE FOR QUADRANT
PP1001/PP18	COVER FOR SPIRAL GEARBOX
PP1001/PP21	COVER FOR SPIRAL GEARBOX
PP1001/PP23	RISE AND FALL NUT
PP1001/PP26	REAR END CAP
PP1001/PP39	SPACING COLLAR
PP1001/PP43	STOP HOLDER FOR EXTENSION TABLE
PP1001/PP67	SPIRAL GEAR
PP1001/PP81	ADJ. SCREW FOR MOTOR
PP1001/PP82	NUT FOR MOTOR PLATE
PP1001/PP86	FILLING IN STRIP (MAIN TABLE)
PP1001/PP87	FILLING IN STRIP (SLIDING TABLE)
PP1001/PP88	ARM CARRYING RIVING KNIFE BRACKET
PP1001/PP93	BRAKE LEVER
PP1001/PP98	FILLING IN PIECE (SLIDING TABLE)
PP1001/PP99	SCALE FOR CANTING
PP1001/PP101	RIVING KNIFE
PP1001/PP102	RIVING KNIFE MOUNTING PLATE
PP1001/PP105	PLATE CARRYING MOTOR ADJ. SCREW
PP1001/PP121	SLIDING TABLE STOP SCREW
PP1001/PP129	SPIRAL GEAR
PP1001/PP130	LIP PLATE
PP1001/PP131	WEAR STRIP
PP1001/PP140	RULE FOR STANDARD TABLE
PP1001/PP149	RIVING KNIFE BRACKET
PP1001/PP158	ARM CARRYING POINTER
PP1001/PP159	POINTER
PP1001/PP164	PLUNGER CAP
PP1001/PP165	TAPER PLUNGER FOR SLIDING TABLE

PP1001/PP169	REAR FLANGE FOR STUB ARBOR
PP1001/PP172	FRONT FLANGE FOR 1 $\frac{1}{4}$ " DIAMETER STUB ARBOR
PP1001/PP175	1 $\frac{1}{4}$ " DIAMETER STUB ARBOR FOR SAW
PP1001/PP176	LOCKNUT FOR STUB ARBOR
PP1001/PP206	CRANK HANDLE
PP1001/PP212	RAIL FOR EXTENSION TABLE
PP1001/PP222	FENCE SLIDE
PP1001/PP225	FENCE ADJ. SCREW
PP1001/PP227	DOVETAIL BOLT
PP1001/PP229	LOCKING NUT
PP1001/PP230	LOCKING HANDLE
PP1001/PP231	CLAMP NUT
PP1001/PP232	POINTER FOR FENCE
PP1001/PP241	LOCKNUT FOR STUB ARBOR
PP1001/PP243	PILLAR CARRYING GUARD
PP1001/PP244	SUPPORT ARM
PP1001/PP245	ARM CARRYING GUARD
PP1001/PP246	RAISING SCREW
PP1001/PP256	LOCKING PAD FOR FENCE
PP1001/PP257	PIVOT PIN FOR TURNOVER STOP
PP1001/PP258	ROLLER FOR EXTENSION TABLE
PP1001/PP259	PIVOT PIN FOR FENCE
PP1001/PP501	MAIN FRAME
PP1001/PP502	MAIN TABLE
PP1001/PP503	SLIDING TABLE
PP1001/PP505	SPINDLE SLIDE HOUSING
PP1001/PP506	SPIRAL GEARBOX FOR CANTING MOTION
PP1001/PP508	BRACKET CARRYING INTERMEDIATE SLIDE
PP1001/PP509	BRACKET CARRYING INTERMEDIATE SLIDE
PP1001/PP510	EXTENSION FOR GEARBOX
PP1001/PP512	QUADRANT SEATING
PP1001/PP513	QUADRANT SEATING

PP1001/PP515	EXHAUST DEFLECTOR
PP1001/PP522	SPINDLE PULLEY
PP1001/PP523	MOTOR PULLEY
PP1001/PP524	FRONT END CAP
PP1001/PP525	COVER CARRYING BRAKE LEVER
PP1001/PP526	PUSH BUTTON HOUSING
PP1001/PP530	SPINDLE HOUSING AND MOTOR SLIDE
PP1001/PP531	OUTER RAIL OF EXTENSION TABLE
PP1001/PP532	INNER RAIL OF EXTENSION TABLE
PP1001/PP533	BRAKE SHOE
PP1001/PP534	BRAKE SHOE
PP1001/PP536	FENCE PIVOT BRACKET
PP1001/PP539	COWL FOR FAN
PP1001/PP545	CENTRE RAIL OF EXTENSION TABLE
PP1001/PP546	FENCE
PP1001/PP551	NUT FOR CANTING SCREW
PP1001/PP552	PIVOT SHAFT FOR CANTING GEARBOX
PP1001/PP553	BRAKE LEVER
PP1001/PP554	BRAKE DRUM
PP1001/PP556	SCREW FOR CANTING
PP1001/PP557	RETAINING PLATES FOR INTERMEDIATE SLIDE
PP1001/PP559	FILBOE FOR BRAKE CABLE
PP1001/PP561	BALL BEARING LOCKNUT
PP1001/PP564	LOCKING STUD
PP1001/PP566	LIP PLATE FOR MAIN TABLE
PP1001/PP567	LIP PLATE FOR MAIN TABLE
PP1001/PP570	BELT DRIVEN SPINDLE
PP1001/PP571	BELT DRIVEN SPINDLE WITH LOOSE ARBOR
PP1001/PP576	KEY FOR SPINDLE
PP1001/PP579	PIVOT PIN FOR BRAKE LEVER

PP1001/PP580 FILBOE FOR BRAKE CABLE
PP1001/PP581 FILBOE FOR BRAKE CABLE
PP1001/PP582 BRAKE SHOE PIVOT PIN
PP1001/PP583 END RETAINING PLATES FOR SLIDE RODS
PP1001/PP591 RAIL CARRYING LINEAL BEARINGS
PP1001/PP592 RETAINING PLATE FOR SLIDE RODS
PP1001/PP594 LEG CARRYING EXT. TABLE RAIL
PP1001/PP595 EXHAUST NOZZLE
PP1001/PP596 REAR COVER FOR MAIN FRAME
PP1001/PP599 COVER FOR SPINDLE SLIDE HOUSING
PP1001/PP600 COVER FOR SLIDING TABLE

PP1001/1 FORM HANDLE
PP1001/1A DRIVING PEG
PP1001/2 COLLAR
PP1001/2 HORN HANDLE
PP1001/2 SPRING
PP1001/2A BALL BEARING LOCKNUT
PP1001/2A FRONT SAW COLLAR
PP1001/2C SAW COLLAR
PP1001/60 GREASE RETAINER

PP1001/EJ49 STOP
PP1001/EKA525 LOCKING BOSS
PP1001/EKA526 LEVER FOR LOCKING BOSS
PP1001/FC217 CLAMPING BOLT FOR OUTFEED GUIDES
PP1001/FD8338 GUARD FOR AIR INLET
PP1001/FM654 HANDLE FOR CLAMP NUT
PP1001/M1833 DUST COVER FOR THRUST BEARING
PP1001/PJ93 NUT FOR SPINDLE

PP1001/PK16	FRONT FENCE PLATE
PP1001/PT22	PAD FOR FOOT LEVER
PP1001/SG255	ARM BRACKET
PP1001/SG256	BASE
PP1001/SG257	CAP FOR RAISING SCREW
PP1001/SG264	LOCKING HANDLE
PP1001/SKF1306	BEARING
PP1001/SKF6309	BEARING
PP1001/WT1326	10" HANDWHEEL
PP1001/XG3	SUPPORT BRACKET
PP1001/ZE1	STATOR FRAME
PP1001/ZE3	REAR BEARING HOUSING
PP1001/ZZ14	ROTOR FAN

www.DaltonsWadkin.com

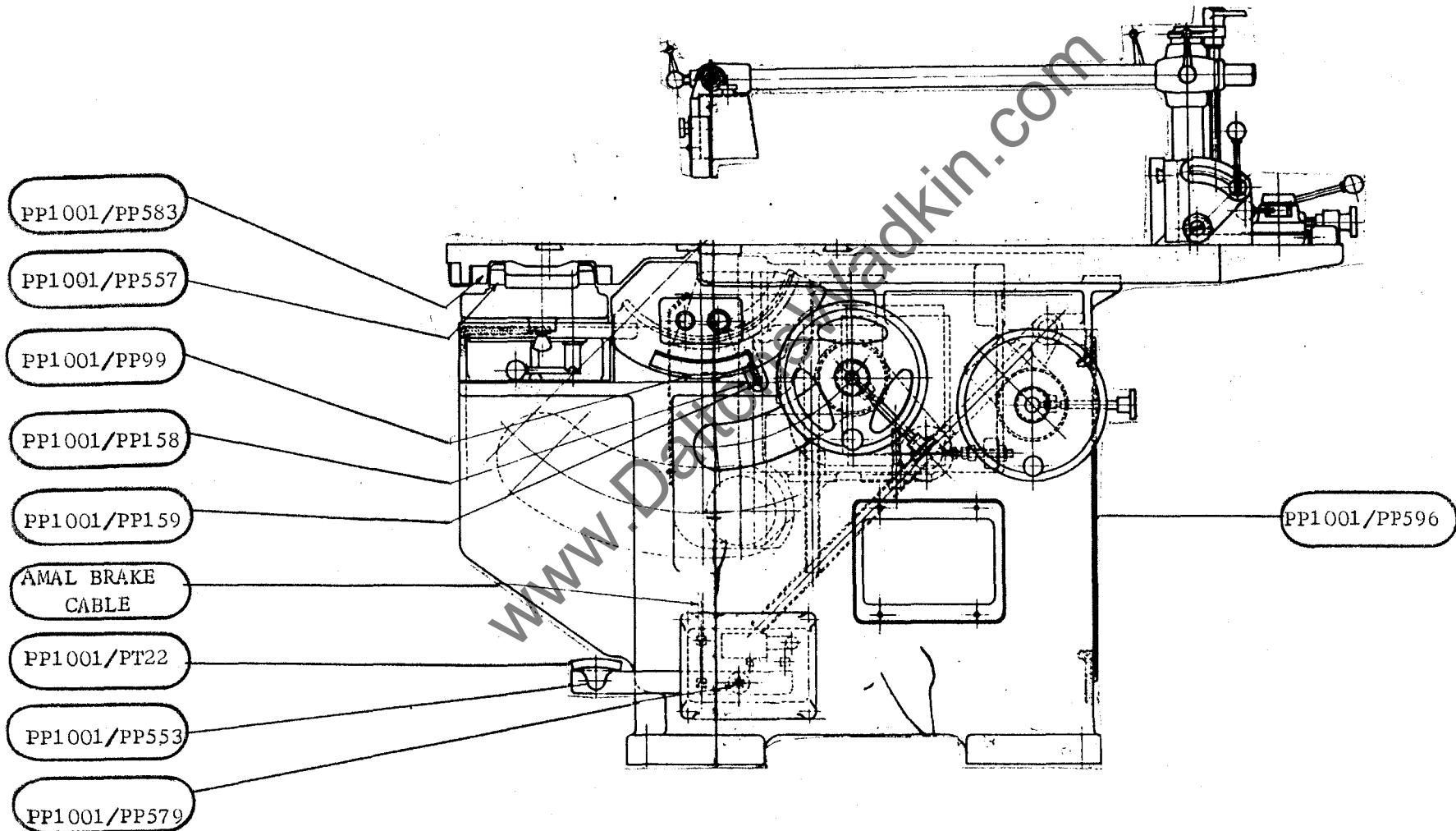

HEAVY DUTY HIGH PRECISION SLIDING TABLE DIMENSION SAW - PP

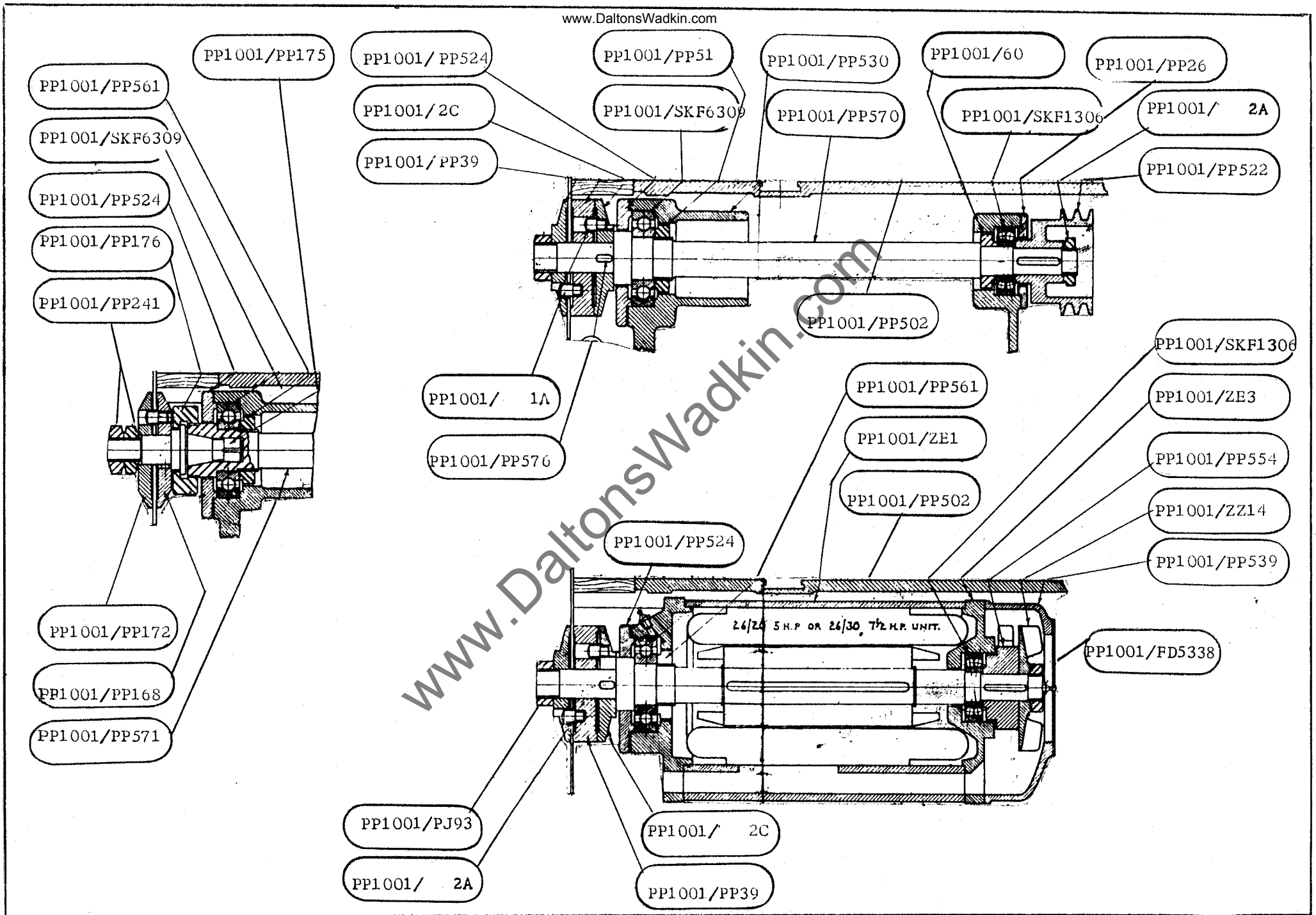

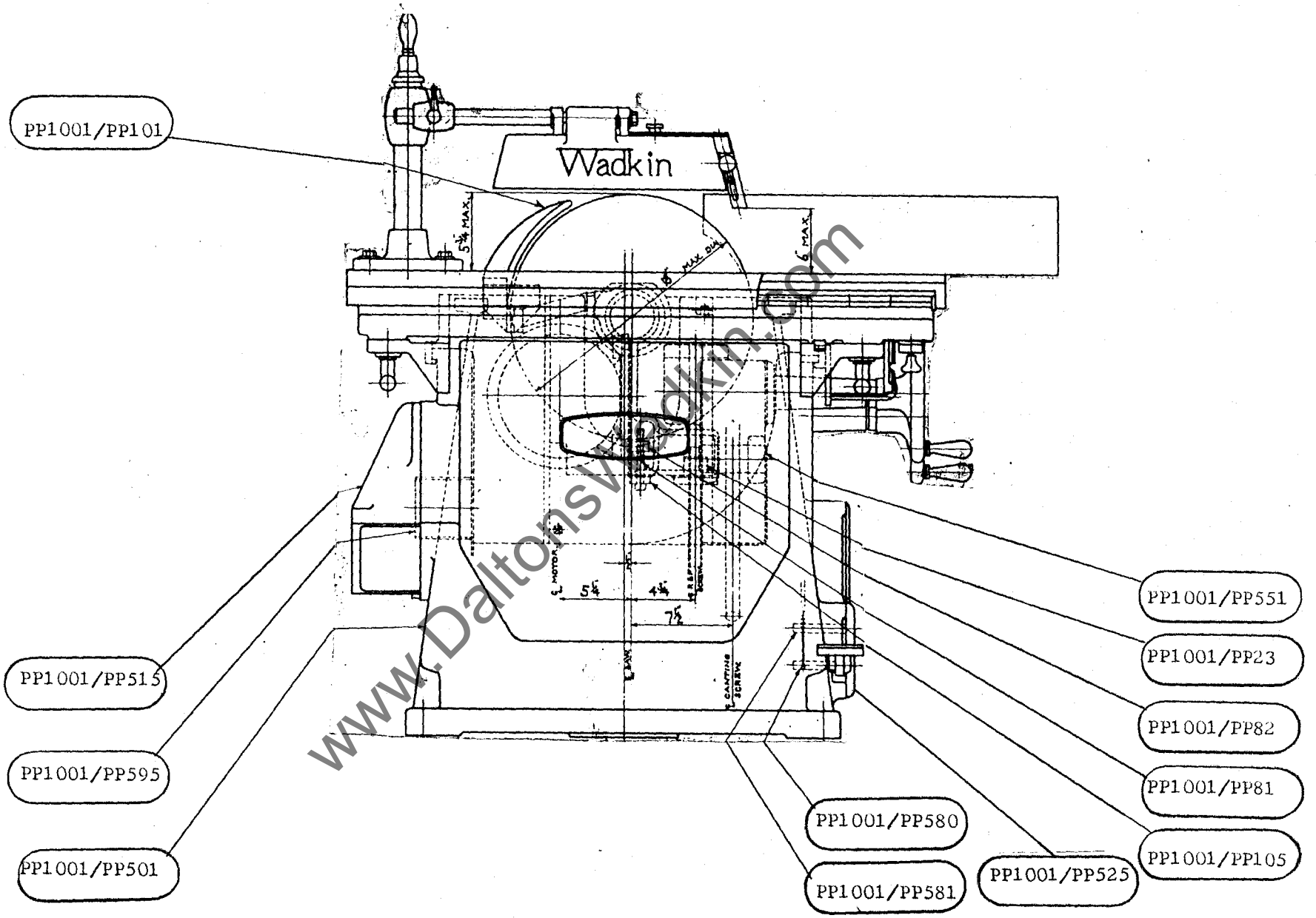

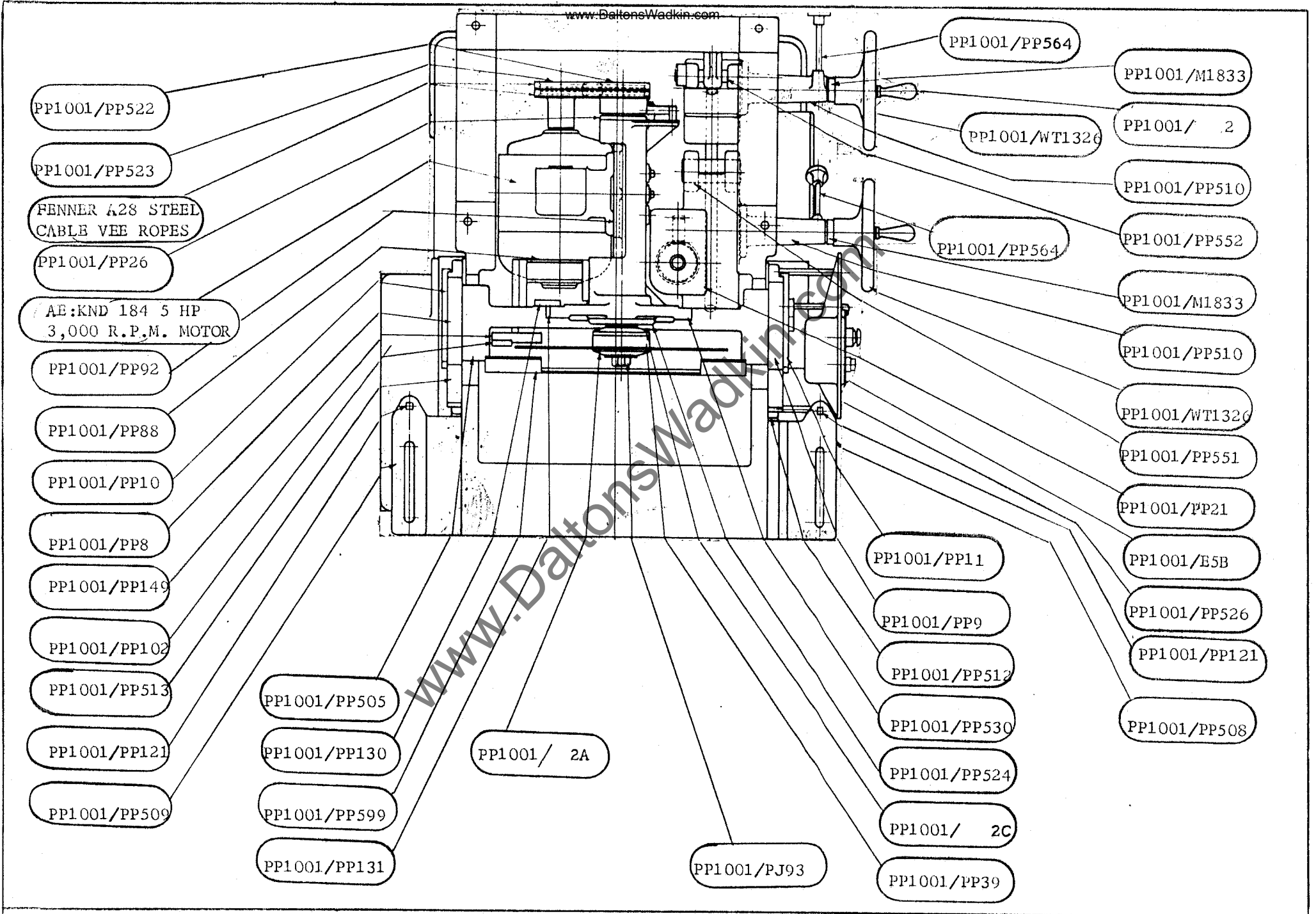

POLLARD $\frac{3}{8}$ " DIA 3" LG
SECTIONS LINEAL BRG. &
 $\frac{3}{16}$ " DIA BALL BRGS.

PP1001/PP592

PP1001/PP87

PP1001/PP165

PP1001/PP592

PP1001/PP591

PP1001/PP600

PP1001/ 2

PP1001/PP164

PP1001/PP508

PLASTIC KNOB
RENCOL PATTERN
NO.19 $1\frac{3}{4}$ " DIA

PP1001/PP231

PP1001/FM654

PP1001/PP591

PP1001/PP503

PP1001/PP98

PP1001/PP566

PP1001/PP502

PP1001/PP121

PP1001/PP9

PP1001/PP11

PP1001/PP512

