



NZ 300/350

**PLANNERHEAD
GRINDER**

INSTRUCTION MANUAL No.4015/2

**MANUFACTURERS E.C. DECLARATION
OF CONFORMITY**

The following machine has undergone "Conformity Assessment" and has undergone Self Assessment in accordance with:-

Schedule IV of the Supply of Machinery (Safety) Regulations 1992 and Amendment No. 2063

COMPANY

Wadkin Ultracare Limited
Franks Road
Hilltop Industrial Park
Bardon
Leicestershire
LE67 1TT

RESPONSIBLE PERSON

Mr J P Smith (Director)

MACHINE DESCRIPTION

TYPE Planerhead Grinder

MODEL NZ 300/350

DIRECTIVES COMPLIED WITH

Supply of Machinery (Safety) Regulations 1992
Amendment No. 2063 1994
Draught Proposal CEN/TC 142
ISO 9001 Part 1

**SIGNED ON BEHALF OF WADKIN
ULTRACARE LTD.**



.....

PREFACE

IMPORTANT

IT IS OUR POLICY AND THAT OF OUR SUPPLIERS TO CONSTANTLY REVIEW THE DESIGN AND CAPACITY OF OUR PRODUCTS. WITH THIS IN MIND WE WOULD REMIND OUR CUSTOMERS THAT WHILE THE DIMENSIONS AND PERFORMANCE DATA CONTAINED HEREIN ARE CURRENT AT THE TIME OF GOING TO PRESS, IT IS POSSIBLE THAT DUE TO THE INCORPORATION OF THE LATEST DEVELOPMENTS TO ENHANCE PERFORMANCE, DIMENSIONS AND SUPPLIERS MAY VARY FROM THOSE ILLUSTRATED.

THIS MANUAL IS WRITTEN AS A GENERAL GUIDE. A TYPICAL MACHINE IS SHOWN TO ILLUSTRATE THE MAIN FEATURES.

**Failure to comply with instructions in this book
may invalidate the guarantee.**

**BE CAREFUL
THIS MACHINE CAN BE DANGEROUS
IF IMPROPERLY USED**

Always use guards.
Keep clear until rotation has ceased.
Always operate as instructed
and in accordance with good practice.
Read instruction manual before installing,
operating or maintaining machine.

*Manufactured by : WADKIN PLC
Franks Road
Hilltop Industrial Park
Bardon Hill
Coalville, LE67 1TT
England*

Telephone No. : +44(0)870 850 9111

Fax No. : +44(0)870 240 0575

Website : www.wadkinultracare.com

E mail : info@wadkinultracare.com





HEALTH AND SAFETY

The CE mark on this machine signifies that an EC declaration of conformity is drawn up indicating that the machine is manufactured in accordance with the Essential Health and Safety Requirements of the 'Supply of Machinery (Safety) Regulations 1992'.

The 'requirements for supply of relevant machinery' in the General Requirement of the Regulations are not only that the machine satisfies the relevant essential health and safety requirements, but also that 'the manufacture carries out the necessary research or tests on components, fittings or the complete machine to determine whether by its design or construction the machine is capable of being erected and put into service safely'.

Persons who install this machine have duties under the 'Provision and use of Work Equipment Regulations 1992'. An indication of these duties is given in the following extracts, but the user should be familiar with the full implications of the regulations.

REGULATION 5 requires that;

Every employer shall ensure that work equipment is so constructed or adapted as to be suitable for the purpose for which it is used or provided.

In selecting work equipment, every employer shall have regard to the working conditions and to the risks to health and safety of persons which exist in the premises or undertakings in which that work equipment is to be used and any additional risk posed by the use of that work equipment.

Every employer shall ensure that work equipment is used only for the operations for which, and under conditions for which, it is suitable.

In this regulation 'suitable' means suitable in any respect which it is reasonably foreseeable will affect health or safety of any person.

The Provision and Use of Work Equipment Regulations also include requirements as follows:-

regulation 6 - maintenance

regulation 7 - specific risks

regulation 8 - information and instructions

regulation 9 – training

Note :-

Attention is drawn to those requirements of the 'Woodworking Machines Regulations 1974' which are not replaced by the Supply of Machinery (Safety) Regulations or other, e.g; Regulation 13 of the Woodworking Machinery Regulation, - 'Training', still applies.

Whilst the prime duty for ensuring health and safety rests with employers, employees too have legal duties, particularly under sections 7 and 8 of the Health and Safety at Work Act. They include :-

Taking reasonable care for their own health and safety and that of others who may be affected by what they do or don't do;

co-operating with their employer on health and safety;

not interfering with or misusing anything provided for their health, safety and welfare.

These duties on employees have been supplemented by regulation 12 of the Management of Health and Safety at Work Regulations 1992. One of the new requirements is that employees should use correctly all work items provided by their employer in accordance with their training and the instructions they receive to enable them to use the items safely.

Noise

Noise levels can vary widely from machine to machine depending on the conditions of use. Persons exposed to high levels, even for a short time, may experience temporary partial hearing loss and continuous exposure to high levels can result in permanent hearing damage.

The Noise at Work Regulations 1989 place legal duties on employers to prevent damage to hearing.

There are three levels of noise defined in regulation 2;



HEALTH AND SAFETY

Regulations (COSHH) 1989 place legal duties on employers to ensure that :-

the exposure of his employees to substances hazardous to health is either prevented or, where this is not reasonably practicable, adequately controlled.

..... adequate control to exposure of employees to a substance hazardous to health shall be secured by measures other than the provision of personal protective equipment.

where the measures taken in accordance with the paragraph above do not prevent or provide adequate control of exposure to substances hazardous to the health of employees, then in addition to taking those methods, the employer shall provide those employees with such suitable personal protective equipment as will adequately control their exposure to substances hazardous to health.

Instructions for Use

Machinery manufacturers are required by the Supply of Machinery Safety Regulations to provide comprehensive 'Instructions for Use' of equipment, it is important that this information is transmitted to the person using the machine.

The first action level :-

a daily personal noise exposure ($L_{EP,d}$) of 85dB(A)

The second action level :-

a daily personal noise exposure ($L_{EP,d}$) of 90dB(A)

The peak action level :-

a peak sound pressure of 200 pascals (140dB re 20pa)

The exposure level is obviously influenced by the emission level of all the equipment in use.

Emission levels for machines are provided in the particular machine instruction manual.

These levels are measured in accordance with ISO 7960 under certain specified test conditions, they do not necessarily represent the highest noise level, which is influenced by many factors, eg number of spindles in operation, type and condition of work piece, spindle speeds etc.

For regulations and information on relevant personal protective equipment i.e. ear defenders, employers should refer to the Personal Protective Equipment at Work Regulations 1992.

Dust

Wood dust can be harmful to health by inhalation and skin contact and concentrations of small particles in the air can form an explosive mixture.

The Control of Substances Hazardous to Health



HEALTH AND SAFETY

IMPORTANT

training under the supervision of a trained operator.

SAFETY PROCEDURES AND CONSIDERATIONS

To ensure safe working conditions, persons operating and assisting with the operation of this machine must ensure that they read and fully understand the instructions given within this manual and have received sufficient training in the use of the machine and the safety aspects to be observed.

Grinding wheels that are damaged or improperly used are dangerous. All users should take sensible precautions in their handling, storage mounting and use.

If a grinding wheel breaks whilst running, pieces fly from the wheel. The wheel guard must always be used.

The grinding process produces sparks and dust. Eye protection must always be used. Coolant should always be used to prevent airborne dust.

Safety requirements for installing, operating and maintaining the machine are described in the relevant sections of this manual.

Keep the floor area around the machine clean and free from refuse. Do not allow the floor around the machine to become slippery.

Stop the machine and report immediately to a person in authority any actual or potential malfunction or operator hazard. Do not attempt to repair or rectify the machine unless qualified and authorised to do so.

The operator must not leave the machine running whilst unattended.

Never by-pass interlocks.

Note :-Persons under the age of 18 years must not operate the machine except during a course of

WARNING :-

Failure to observe correct operating procedures prior to and during operation of this machine can result in severe injury.

DO NOT attempt to operate the machine while under the influence of anything that reduces your alertness.



INDEX

INDEX

<u>Section</u>	<u>Title</u>	<u>Page</u>
	Machine and Test Numbers	
	Preface	
	Manufacturer	
	Health and Safety	
	Safety Considerations	
1	General Description	
1.1	Machine Layout	1 : 1
1.2	Intended Uses	1 : 2
1.3	Technical Specification	1 : 3
1.4	Straight Knife Grinding Theory	1 : 5
2	Installation	
2.1	Moving the Machine	2 : 1
2.2	Space requirements	2 : 1
2.3	Foundations	2 : 1
2.4	Levelling	2 : 3
2.5	Electrical Supply	2 : 3
2.6	Lighting	2 : 3
2.7	Cleaning	2 : 3
3	Preparation for Use	
3.1	Training	3 : 1
3.2	Coolant System	3 : 1
3.3	Controls	3 : 3
3.4	Start up and Testing	3 : 5
3.5	Tools and Accessories	3 : 5



INDEX

<u>Section</u>	<u>Title</u>	<u>Page</u>
4	Operating Instructions	
4.1	Safety	4 : 1
4.2	The Grinding Wheel	4 : 2
4.3	Knife Guide Setting	4 : 2
4.4	Mounting the Planer Head	4 : 3
4.5	The Indexing Unit	4 : 3
4.6	Setting the Clearance Angle	4 : 4
4.7	Grinding Head Adjustment	4 : 5
4.8	Knife Preload	4 : 6
4.9	Table Traverse Limits	4 : 7
4.10	Coolant Application	4 : 7
4.11	Setting Grinding Parameters	4 : 8
4.12	Auto-cycle Grinding	4 : 10
4.13	Interruption of Auto-cycle	4 : 10
4.14	Depth of Cut Alteration	4 : 11
4.15	Feed Rate Alteration	4 : 11
4.16	Clearance Angle Gauge (optional extra)	4 : 11
4.17	Care of the Machine	4 : 12

www.DaltonsWadkin.com



INDEX

<u>Section</u>	<u>Title</u>	<u>Page</u>
5	Maintenance	
5.1	Safety	5 : 1
5.2	Cleaning	5 : 1
5.3	Lubrication	5 : 1
5.4	Wheel Mounting and Guard	5 : 2
5.5	Coolant System	5 : 2
5.6	Electrical System	5 : 3
5.7	Fault Finding	5 : 4
5.8	Machine Alignments	5 : 5
6	Illustrated Parts List	
	Table Assembly	6 : 2
	Indexing Unit	6 : 8
	Head	6 : 12
	Infeed Mechanism	6 : 20

APPENDIX

A.1	Approved Lubricants
A.2	Grinding Coolant Data
A.3	Anti-bacterial Solution Data
A.4	Tools etc. Supplied with Machine
A.5	Accessories Available
A.6	Suggested Spares
A.7	Clearance Angle Chart
A.8	Electrical Circuit Diagram



SECTION 1 : GENERAL DESCRIPTION

1.1 MACHINE LAYOUT

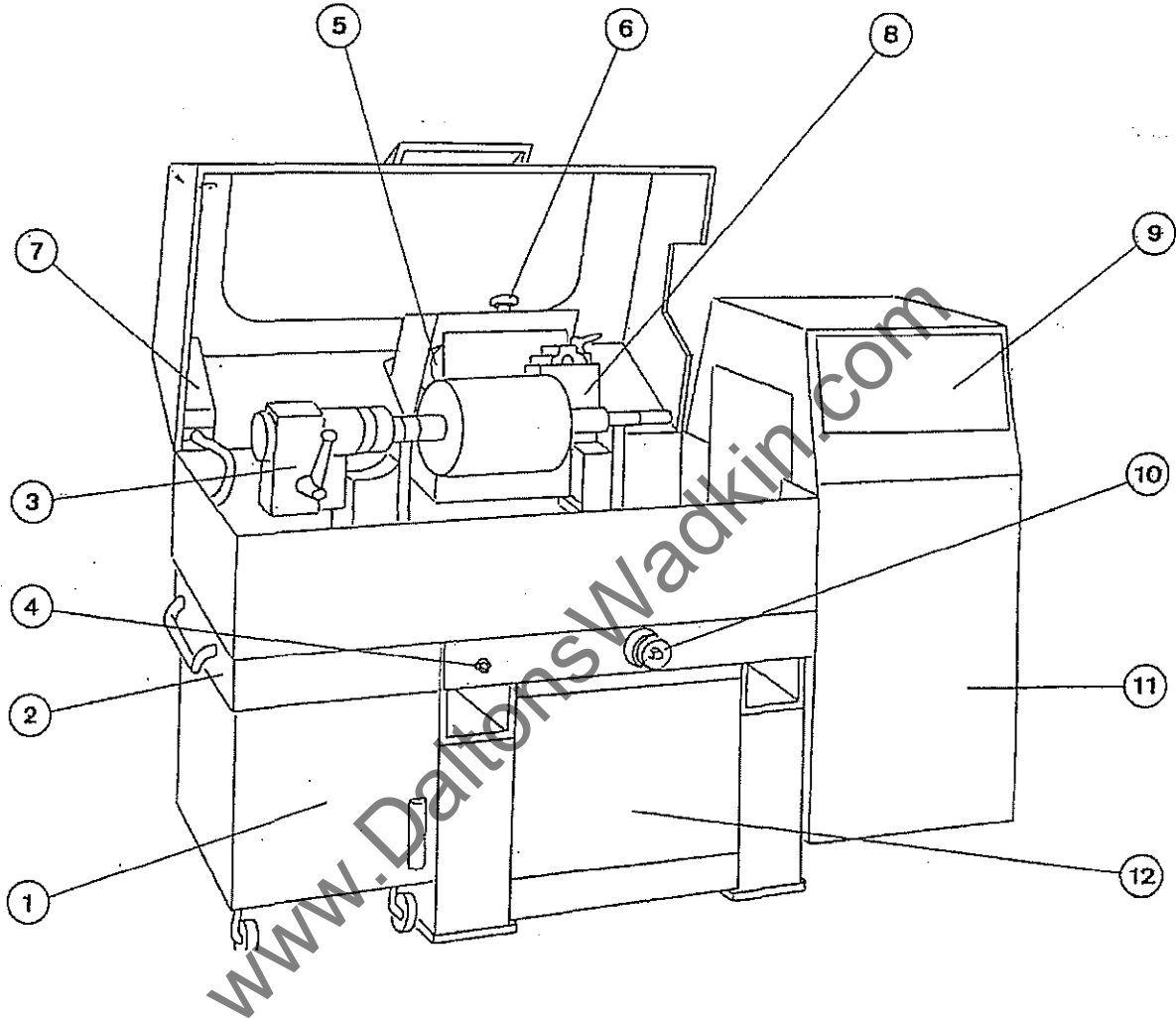

Fig. 1a

- 1 Coolant tank
- 2 Weir filter tray
- 3 Indexing unit
- 4 Table grease points
- 5 Spindle drive motor
- 6 Spindle adjustment handwheel
- 7 Internal light
- 8 Knife guide
- 9 Machine control panel
- 10 Infeed control handwheel
- 11 Electrical cabinet
- 12 Storage cupboard



1.2 INTENDED USES

The Wadkin automatic straight knife grinder type NZ is a tool grinding machine designed for the grinding of planerheads used primarily in the woodworking industry.

Planerheads are used to plane flat surfaces on timber as distinct from profile cutterheads which are used to produce mouldings. Planerheads always use straight knives to form a cylindrical type of cutterhead - hence the term 'straight knife grinding'.

The straight knives are set into the cutterhead prior to grinding and the cutterhead is mounted onto the machine. A knife guide in front of the grinding wheel is used to control the knife position during grinding.

Grinding is carried out using C.B.N. (Borazon) or diamond wheels with a solid aluminium core. Conventional bonded grit wheels must not be used.

The grinding process is carried out under the control of a programmable control system, thereby releasing the machine operator for other duties whilst the planerhead is ground. A work zone enclosure is provided to give protection during unsupervised operation.

A wet grinding coolant system is provided to prevent burning of the cutters and to remove the dust and debris generated during the grinding process.

Note: This machine is not designed for the grinding of aluminium, magnesium or other materials which might create risks of fire or explosion. It is not designed for use in an explosive atmosphere.



1.3 TECHNICAL SPECIFICATION

MACHINE CAPACITY

Maximum length of cutterhead :	330 mm	(13")
Maximum cutting circle (NZ300).....	300 mm	(11.8")
(NZ350).....	356 mm	(14")
Minimum cutting circle (NZ300).....	80 mm	(3.15")
(NZ350).....	136 mm	(5.35")
Maximum number of knives :	30	

GRINDING WHEELS

Diameter	100 mm	(4")
Bore	20 mm	(0.787")
Spindle speed	5000 rpm Max.	

MACHINE TABLE

Traverse speed (infinitely variable)	0.6 - 3 m/min	(2 - 10 fpm)
--	---------------	--------------

INDEXING UNIT

Indexing rate	1 rpm plus higher speed of 4 rpm for 8 knives or less	
---------------------	---	--

MOTOR OUTPUTS

Straight knife spindle	0.75 Kw	(1 h.p.)
Machine table	0.09 Kw	(0.12 h.p.)
Indexing unit	0.024 Kw	(0.03 h.p.)
Coolant pump.....	0.06 Kw	(0.08 h.p.)

COOLANT SYSTEM

Tank capacity - maximum	31 litre	(7 galls)
- minimum	13.5 litre	(3 galls)

MACHINE DIMENSIONS

Height	1115 mm	(44")
Width	1090 mm	(43")
Length	1825 mm	(72")
Weight (nett)	600 kg	(1320 lbs)



NOISE EMISSION VALUES

MACHINE CRITERIA :

The machine was free standing on a concrete floor, not bolted down and not on any vibration dampening.

The figures quoted in the noise emission chart are emission levels and not necessarily safe working levels.

Whilst there is a correlation between emission levels and exposure levels, this cannot be used reliably to determine whether or not further precautions are required to achieve safe working levels.

GRINDING CRITERIA :

Knives : 4mm x 230mm H.S.S.

Factors that influence the actual level of exposure to the work force include the duration of exposure, the characteristics of the work room, sources of noise etc. i.e. the number of machines and other adjacent processes, also the permissible exposure levels can vary from country to country.

Straight knife grinding :

Wheel : GW 301, 100mm dia.

Speed : 4880 rpm

Traverse speed : 1.6 m/min

Emission levels, however will enable the user of the machine to make a better evaluation of the 'hazard and risk'.

NOISE EMISSION CHART		
MODEL :-	NZ	
TYPE :-	NZ 300/350 50Hz 415v	
DECLARED NOISE EMISSION VALUE in accordance with ISO 4871		
	Idling	Operating
Declared A-weighted sound power level L_{WA} ,in dB re 1 pW	69	76
Declared A-weighted emission sound level (L_{pAd}) in dB re 20 μ Pa at the operator's position	60	66
Environmental correction factor (K)	3	
values determined according to specific test code ISO 3744		



1.4 STRAIGHT KNIFE GRINDING THEORY

The basic objectives are to have all of the cutting edges on the same cutting circle (concentricity) and to produce a true cylindrical form on the planerhead i.e. identical cutting diameters at both ends of the planerhead. A typical figure quoted for the concentricity requirement is to have all knives within 5 microns (0.005 mm / 0.0002").

To achieve this level of accuracy it is necessary to have a rigid wheel and cutter support to avoid any deflection. A small diameter wheel is therefore used which allows for a rigid knife guide mounting.

The accuracy of the linear bearing rails of the carriage is used to generate the cylindrical form of the planerhead. This eliminates potential inaccuracies due to template making or mounting.

A face grinding wheel is used in preference to a peripheral grinding wheel for two reasons. Firstly, for a given clearance angle, a stronger cutter tip is produced (*Fig. 1b*) and secondly, the planerhead can be ground more times before the knives require re-setting (*Fig. 1c*).

A C.B.N. (Borazon) wheel wears far less quickly than a conventional bonded grit wheel and does not require dressing. This eliminates potential inaccuracies due to wheel wear.

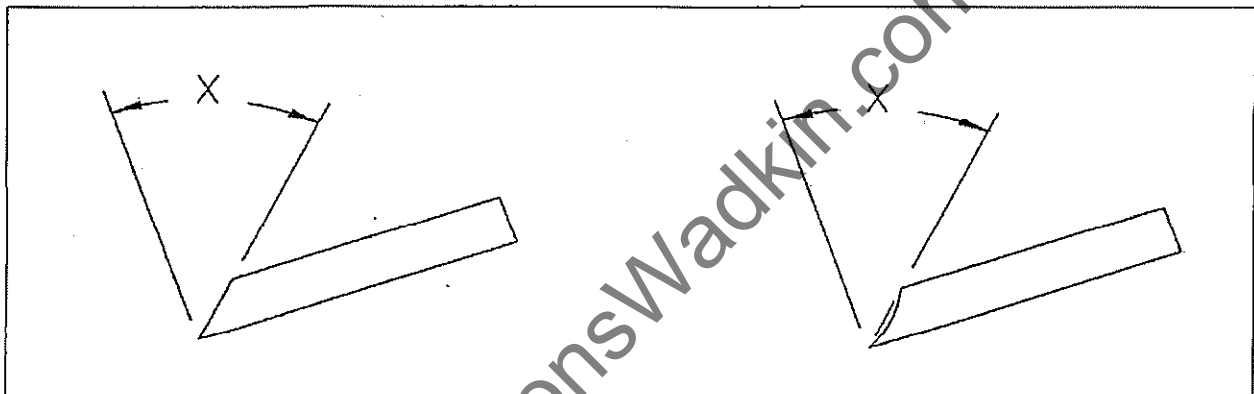

Fig.1b

Face ground

Peripheral ground

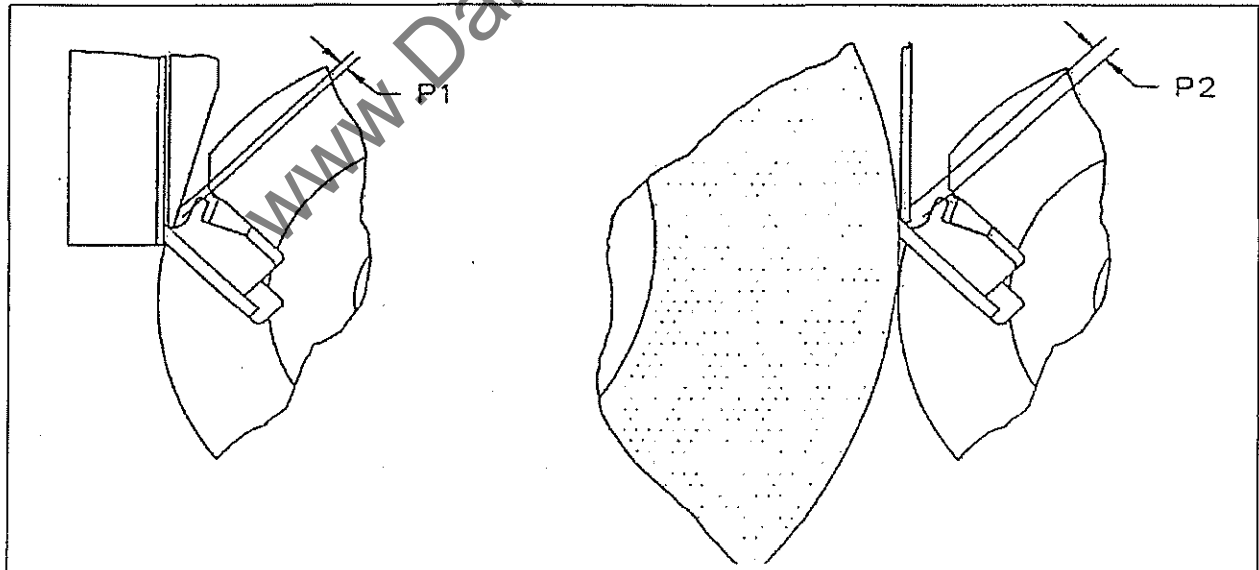

Fig. 1c

Face grinding

Peripheral grinding

The minimum knife projection which can be ground P_1 is less than P_2 .



SECTION 2 : INSTALLATION

2.1 MOVING THE MACHINE

Verify the weight of the machine which is given in the Technical Specification (see section 1.3). Ensure that all lifting equipment used is capable of lifting this weight as a minimum.

Always use the lifting points provided. Lifting using other parts of the machine can be dangerous and can cause damage to the machine.

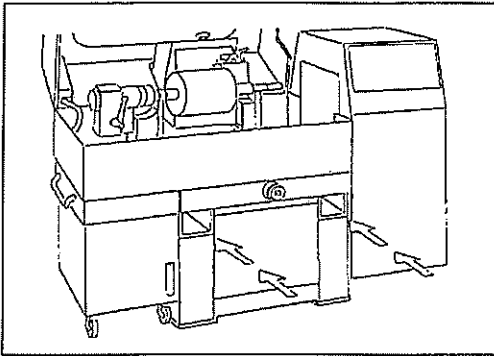

Fig. 2a Lifting points

The machine is designed to be easily lifted and manoeuvred using a fork lift truck. The forks should be at least 800 mm (32") long, not more than 125 mm (5") x 63 mm (2 1/2") in section, and capable of lifting the machine weight.

Carefully slide the forks directly into the rectangular hollow steel lifting sections and lift ensuring that the machine body remains parallel with the floor.

If slings are used to move the machine, place a suitable sling through each of the rectangular hollow steel sections of the machine base and bring one end of each up behind the rear coolant tray and the other end of each up the front of the machine.

It is very important to ensure that the lifting slings are suitably arranged to enable the machine to be lifted so that the body is parallel to the floor prior to its siting. Take care to ensure that the slings do not cause damage to the sheet metal covers etc. during lifting.

2.2 SPACE REQUIREMENTS

The foundation plan *Fig. 2b* shows minimum distances for positioning the machine near to walls etc. It should be noted that these are minimum distances and more space should be provided if possible for ease of access during routine maintenance.

It is recommended that a workbench or table be located within easy reach of the machine for loading cutterheads onto arbors etc. An area should also be provided for work in progress.

The operator's working area at the front of the machine should allow sufficient space for safe loading and unloading of the machine. The actual size will depend on the layout of the toolroom, location of workbench etc. The working area should not be cramped.

2.3 FOUNDATIONS

If the floor consists of 100 - 150 mm (4 - 6") of solid concrete no special foundation is necessary. M12 'Hilti' type holding down bolts (not supplied) can be used to secure the machine to the floor.

A good wooden floor should provide adequate foundation for the machine provided that it does not transmit vibration from adjacent machinery.

The machine should be bolted down before use. Final bolting down is carried out during final levelling.



INSTALLATION

SECTION 2

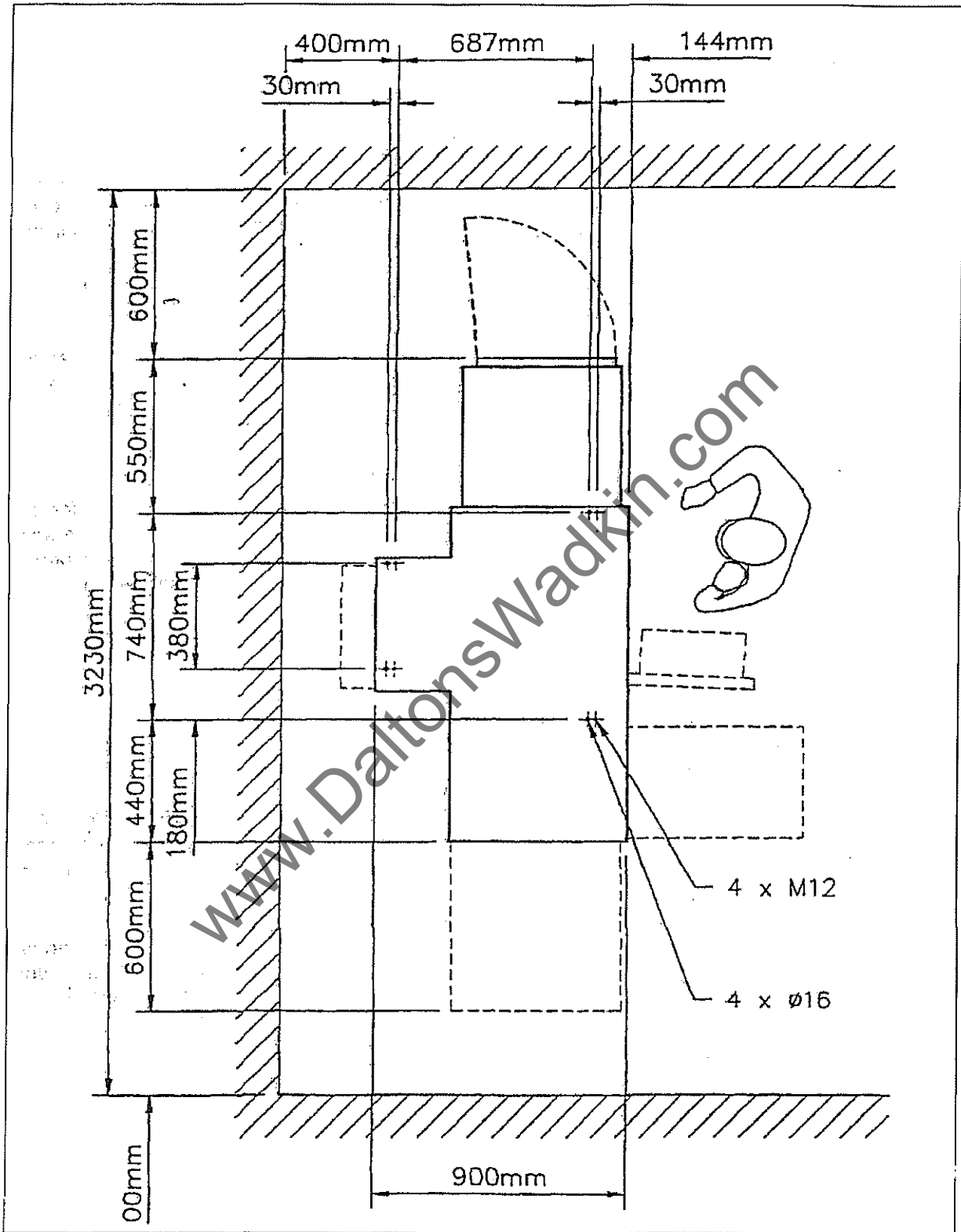

Fig. 2b Foundation plan



2.4 LEVELLING

The machine should be set to a spirit level by adjusting the four levelling screws on the machine base. A slight fall from right to left should be set to ensure that coolant will drain to the outlet holes in the main tray.

Power line to machine should be protected with in-line fuses, rated as listed below, or with equivalent fuses to meet local requirements.

2.5 ELECTRICAL SUPPLY

IMPORTANT : ELECTRICAL WORK SHOULD BE CARRIED OUT BY A COMPETENT ELECTRICIAN

The customer is responsible for an adequate electrical supply. Details of the power requirements are provided on the machine nameplate. The electrical cabling between the motor and the attendant control gear has been carried out by Wadkin prior to despatch. It will only be necessary to connect the 3 - phase power supply to the incoming terminals L1, L2 and L3 at the disconnect switch in the electrical control cabinet.

ENSURE THAT THE MACHINE IS CONNECTED SOLIDLY TO EARTH.

- 1) Check that the electrical supply details on the machine nameplate correspond to the electrical supply available and select the size of main cable to correspond to the current indicated on the machine nameplate.
- 2) Check that the fuses at the electrical supply distribution board are correct.
- 3) Check that all connections are sound.

Fuse Details :

	<u>GEC Spec.</u>	<u>Fuse Size</u>
575v	NIT 16 BS 88	16 Amp
460v	NIT 16 BS 88	16 Amp
415v	NIT 16 BS 88	16 Amp
380v	NIT 16 BS 88	16 Amp
230v	NIT 20 BS 88	20 Amp

2.6 LIGHTING

The area where the machine is installed should be provided with ambient lighting of normal intensity. The machine is equipped with a worklamp for illumination of the immediate working area around the grinding wheel.

2.7 CLEANING

The machine is despatched from Wadkin with all bright surfaces covered with a rust preventative. This must be carefully removed with a cloth dampened with paraffin or diesel.

Ensure that the area around the machine is clean, free from oil, and anything that is likely to cause tripping or slipping.



SECTION 3 : PREPARATION FOR USE

3.1 TRAINING

Grinding operators should be trained in the safe use of each machine which they operate. They must also be given instructions in the safe use of grinding wheels.

It is recommended that personnel involved with the machine are acquainted with the Woodworking Machines Regulations 1974 and also Booklet Number 14 'Safety In The Use Of Woodworking Machines', issued by the Department of Employment and available from Her Majesty's Stationary Office. Also Code of Practice 'Safeguarding Woodworking Machines' Part1 BS6854.

Personnel involved with the use of grinding wheels should be acquainted with the Abrasive Industries Association leaflets 'Safety In The Use Of Abrasive Wheels (General)' and 'DO'S and DONT'S - Safety Guide For Grinding Wheel Users'. Also the Health and Safety Series Booklet HS(G)17, FEPA Safety Code 12-GB-1987 and HSE Guidance Book Note PM22.

In the U.K., the Health and Safety at Work Act (1974) requires that: -

NO PERSON SHALL MOUNT ANY GRINDING WHEEL UNLESS HE HAS BEEN TRAINED AND APPOINTED IN ACCORDANCE WITH THE ABRASIVE WHEELS REGULATIONS 1970 No.535 (REGULATION 9).

It is a statutory requirement that the person who mounts grinding wheels onto the grinding machine shall be a trained and competent person appointed by the factory occupier, and whose name must be registered in an appropriate register.

In other areas local regulations should be checked and adhered to.

In-house training courses for grinding machine operators are run by Wadkin at the Green Lane Road works in Leicester. Demonstrations can also be arranged, contact Wadkin for further details.

3.2 COOLANT SYSTEM

Before handling coolant fluids all operators should be familiar with the appropriate Health and Safety precautions - see Appendix A2.

Refer to *Fig. 3a*

The machine is despatched from Wadkin with the coolant tank [1] fixed to the base of the machine to protect the tank during transit. The weir filter tray [2] should be partly withdrawn to allow access for removal of the two tank fixing nuts [7].

Coolant fluid supplied with the machine should be mixed in the tank according to instructions. The pump [4] should be correctly positioned in the tank. The tank assembly is then wheeled into the operating position directly below the weir filter tray.

If the machine is fitted with a washdown facility, check that the flow control tap handle [6] is in the vertical position. The washdown pipe should be coiled and hung on the tap handle [6] with the free end placed over or into the tank. NOTE: The control tap [6] is located at the rear of the main tray.

The two metal filtration magnets [5] should be correctly positioned in the 'lift-out' weir section [3]. Take care to ensure that fingers are not 'nipped' - the magnets are very strong.

The weir filter tray [2] should be returned to the closed position to complete the coolant system preparation.

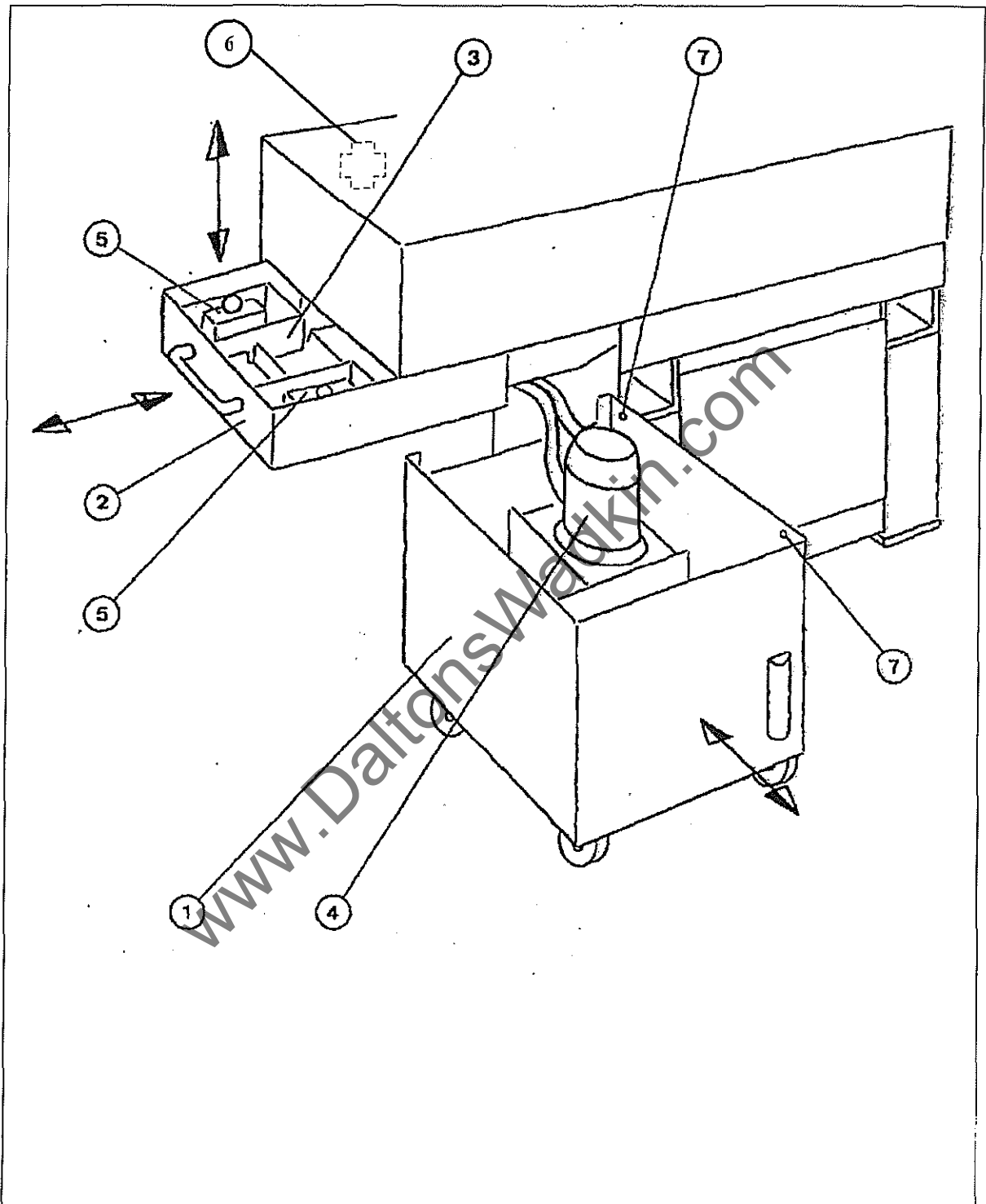
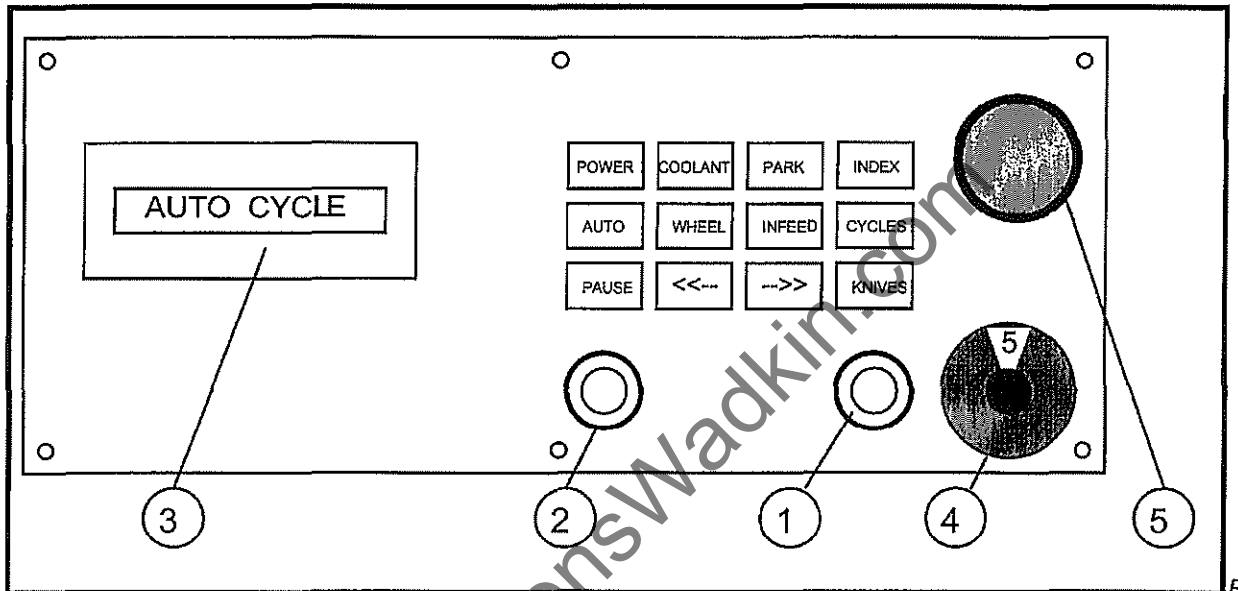

Fig. 3a Coolant system



3.3 CONTROLS

The operator should be familiar with the electrical controls before the machine is used. All the controls are located on the main control panel.



ig. 3b Control panel

[1] The green button is used to start the basic operation of the machine and the power up of the programmable controller.

[2] The red button switches off power to the programmable controller and halts the basic operation of the machine. (Any grinding parameter settings are dumped.)

[3] A vacuum fluorescent dot matrix single line display unit used to display machine status messages, setting information and setting prompts.

[4] The speed control knob is a single turn rotary potentiometer that will allow the operator to control the table traverse speed.

[5] Emergency stop button. Switches off power to the programmable controller and halts the machine. (Any grinding parameter settings are dumped.)

POWER

Status light will illuminate when machine is switched on.

COOLANT

Active only when in manual control. Will switch coolant pump off / on.

PARK

Active only when in manual control. When pushbutton is pressed and held, the table will move to the furthest left position, overriding the table traverse limit switches.

INDEX

Active only when in manual control. When pressed and held, this pushbutton will rotate the cutterhead and arbor. Note : Always ensure cutterhead and knives will not foul before rotating arbor.



PREPARATION

SECTION 3

AUTO

Pushbutton used to initiate auto-cycle routine and to commence grinding cycle.

WHEEL

Active only when in manual control. Switches grinding wheel motor off / on. (Conditional on guard being closed.)

INFEED

Multi-purpose pushbutton :-

- In manual mode, used to infeed grinding head by 0.01 mm for each press of the pushbutton.
- In auto-cycle, this pushbutton is used to verify settings selected in machine set-up.

CYCLES

Active only when in auto-cycle. Used to verify selected number of roughing cycles.

PAUSE

Used to temporarily suspend grinding. First press will suspend grinding. Second press will recommence grinding (conditional on guard being closed).

<<--

Multi-purpose pushbutton :-

- In manual control moves table to the left whilst pushbutton is held.
- In auto-cycle will decrease knife count, cycle count and infeed values for each individual press

-->>

Multi-purpose pushbutton :-

- In manual control moves table to the right whilst pushbutton is held.
- In auto-cycle will increase knife count, cycle count and infeed values for each individual press.

KNIVES

Active only when in auto-cycle. Used to verify selected number of knives in cutterblock.



3.4 TESTING THE MACHINE

Check that all guards and covers are correctly fitted - particularly the wheel guard and lift up enclosure lid.

The main power isolator is located on the cabinet door. This should be turned to the ON position. This will put power onto the machine and the internal hood light should illuminate. Ensure that the emergency stop pushbutton, on the control panel, is pulled out.

Press the green start button. This should initiate the start up of the programmable controller, the single line display, on the control panel should go through various start-up messages, e.g. 'TESTING V1.1', 'SELF TEST OK', etc. When the message 'MANUAL CONTROL' appears, the machine is ready for use.

Ensure that there are no loose items on the grinding spindle. Start and stop the grinding spindle and check the direction of rotation. The spindle should rotate clockwise when viewed from the front of the machine. If the rotation is wrong, any two of the line lead connections at the incoming supply should be reversed by a competent electrician.

Check table movements using "-->>" and "<<--" buttons ensuring that there are no potential foul conditions. Limit switches should prevent movement beyond the permitted travel. Return to the park position using the "PARK" button. Check that the indexing unit rotates using the "INDEX" button. Check the head movement using the "INFEED" button. Various 'clicks' should be heard and the handwheel on the front of the machine should move as the head is moved forward by 0.01 mm for each press of the button.

Start the coolant pump and ensure that there is a good flow of coolant. (Do not run coolant on to a stationary wheel.) The flow control tap is located inside the main enclosure.

Check that the electrical interlock on the enclosure lid is functioning correctly. With the lid closed the grinding spindle can be started. If the enclosure lid is then opened, the spindle should be switched off by the electrical interlock.

3.5 TOOLS AND ACCESSORIES

The tools and accessories supplied with the machine should be unpacked and checked (Appendix A4) to ensure that the machine is complete. Hand tools should be conveniently placed for use by the operator as and when required.

A tool and wheel storage cupboard is provided in the base of the machine. Grinding wheels should be stored carefully to avoid damage.



SECTION 4 : OPERATION

4.1 SAFETY

Grinding wheels - Must always be correctly mounted. The machine is designed to use only C.B.N. or diamond type wheels with a solid aluminium core.

Conventional bonded grit wheels **MUST NOT** be used.

Enclosure - The 'lift-up' enclosure lid should always be in the closed position during grinding. The electrical interlock should be kept in good working order and not interfered with.

Wheel Guard - The Wheel guard and knife guide should always be in the correct position when the wheel is run.

Dust protection - A coolant flow from above aids the cooling of the cutter, but more importantly it washes away all the wheel and grinding dust. Always use coolant when grinding.

Note : Dry grinding requires extraction.

Personal items - such as jewellery, rings, watches, bracelets etc. should be removed. Remove or fasten loose articles of clothing such as neckties, and confine long hair to avoid risk of entanglement.

Protective clothing - Safety aprons, gloves and safety shoes should be worn particularly when handling woodworking cutters.

Barrier cream - the use of a barrier cream is recommended when working with coolant fluids.

Stop the machine - before making adjustments, measuring, loading or unloading, etc.

Keep clear until rotation has ceased.

Lighting - Always ensure adequate lighting. Areas of poor lighting or shadow can create unnecessary risks for the operator.

Care of the machine - Clean down regularly and ensure that the machine is kept in good condition.

Safe operation - of machinery requires constant alertness and close attention to the work in hand.

Materials - This machine is not designed for the grinding of aluminium, magnesium, or other materials which might create risks of fire or explosion.



OPERATION

SECTION 4

4.2 THE GRINDING WHEEL

The straight knife grinding spindle is designed to use C.B.N. (Borazon) or diamond type grinding wheels with a solid aluminium core.

CONVENTIONAL BONDED GRIT WHEELS MUST NOT BE USED

These wheels do not require dressing. The wheel [1] is mounted directly onto the spindle nose with a nut [3] and washer [2].

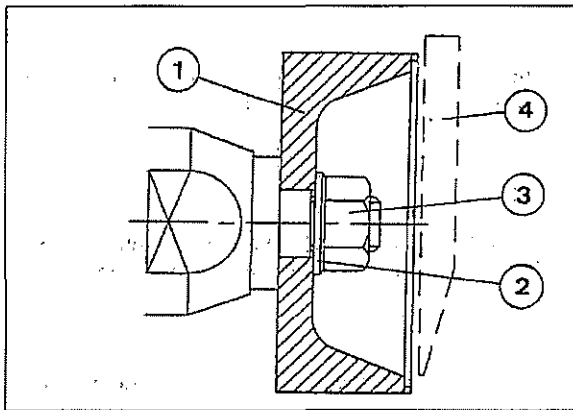

Fig. 4a Grinding wheel mounting

Access to the wheel is obtained by releasing the clamp handle and removing the wheel guard complete with knife guide [4].

When mounting the wheel always inspect the bore for any dirt or damage. Clean any dirt from the bore. If there is any physical damage to the bore it is advisable that a new wheel is used, DO NOT attempt to salvage the wheel - damage suffered by the wheel may not be evident. If a grinding wheel is dropped, it should not be used.

If, when mounting the wheel on the spindle nose, any excessive play is felt between the shaft and the wheel bore the grinding wheel must be scrapped - DO NOT attempt to salvage.

Always use the special washer [2] supplied with the machine to clamp the grinding wheel onto the spindle. Spanner flats are provided on the spindle nose for use during wheel tightening.

Note : The spindle nut [3] has a LEFT HAND thread and tightens by turning anti-clockwise. The correct wheel tightening torque required is 30 Nm (22 ft lbs).

A small amount of unevenness is not uncommon when these wheels are started up, but the wheel should quickly bed down as any high spots are worn down during grinding.

4.3 KNIFE GUIDE SETTING

The knife guide is selected to match the thickness of knife to be ground. The machine is supplied with a knife guide to suit 3 mm and 4 mm thick knives. Optional knife guides are available to suit thicker knives, see Appendix A5.

The knife guide should be mounted onto the wheelguard ensuring the top edge is pushed up to the locating lip, and clamped using four M6 capscrews. Ensure that the face of the wheel is clear of the knife guide before the screws are tightened.

A 1mm thick setting gauge is supplied with the machine to enable the gap between wheel face and knife guide to be accurately set. The clamp handle [2] should be released to allow the wheel guide [1] to slide.

With the gauge inserted in the gap the guard is moved forward to lightly trap the gauge behind the knife guide. The gauge is then removed and the lock [2] secured.

As the wheel wears the gap should be checked and re-set from time to time.

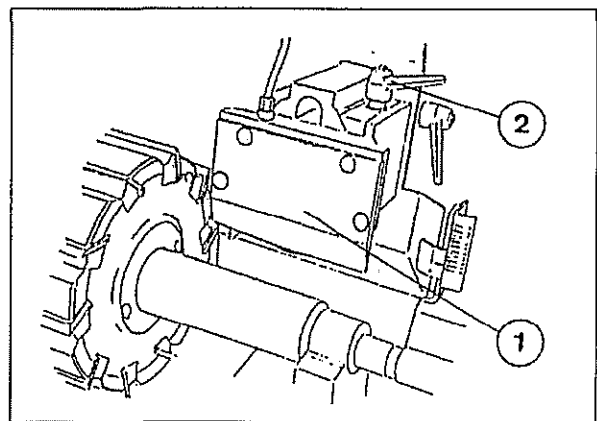

Fig. 4b



OPERATION

SECTION 4

4.4 MOUNTING THE PLANERHEAD

Knives are set into the planerhead ' off machine' before being mounted on to the grinding machine arbor.

Hydro-lock type cutterheads should be pressurised to lock the block onto the arbor. All other cutterheads should be locked onto the arbor using the locking collars supplied.

One half of the locking collar set [1] is clamped either side of the cutterhead. To lock the cutterhead in position, the lock nut [2] of the larger collar is wound firmly against the cutterhead using the tommy bar provided.

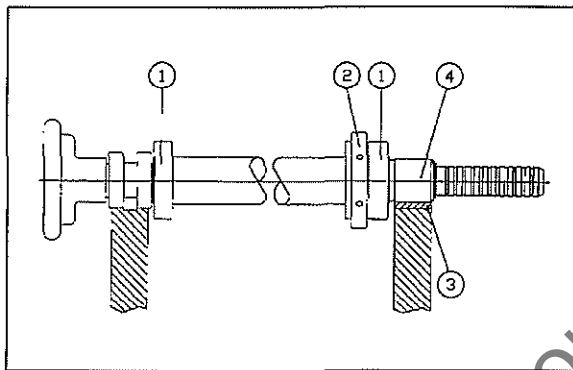

Fig. 4c

Note : The machine is normally supplied with a heavy duty arbor which is fitted with a 37 mm outside diameter bearing [4]. Arbor sizes below 40 mm (1 1/2") diameter are fitted with a 28 mm outside diameter bearing to allow removal of the cutterheads. If the smaller arbor sizes are used an alternative size of shell [3] must be used. (See Appendix A5.)

The planer head should be left free to rotate on the arbor at this stage. The planer head is not finally locked to the arbor until the grinding head and knife preload have been set.

The arbor should be loaded onto the machine and engaged with the indexing unit drive mechanism as follows.

Note : Large heavy blocks may require the use of lifting equipment. Ensure that it is capable of lifting the weight of arbor and block(s). Do not attach lifting equipment to the arbor handle, handwheel or bearings. Use either the main body of the arbor, or the lifting points provided in the cutterblock(s). make sure that any straps, ropes etc. can be

removed before grinding is commenced, load the arbor onto the machine with great care to avoid causing any damage or mis-alignment of the arbor supports.

4.5 THE INDEXING UNIT

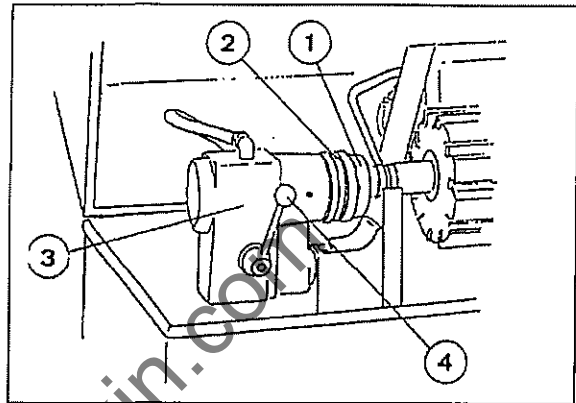

Fig. 4d

IMPORTANT : The grinding wheel must be stationary when loading or unloading the machine. Before the arbor is loaded onto the machine, the table should be moved to the left hand PARK position. The indexing unit [3] is moved clear by moving lever [4] to the left and away from the operator, allowing the unit to swing back to its rest position.

The arbor should be loaded onto the grinder with the handwheel [1] to the left. The pair of arbor bearings should locate over the axial location pin in the left hand arbor support. Ensure that the arbor supports are clean and that the arbor bearings seat correctly. Any grinding debris etc. trapped in the arbor seatings will cause inaccuracies in the ground planerhead.

The indexing unit should be moved to align with the arbor using the handlever [4]. Spring pressure should hold the indexing unit into the arbor handwheel. The arbor should be slowly rotated until the drive tang is located.

Final engagement is carried out by gripping the knurled housing [2] on the indexing unit and rotating it against the torsion spring. The arbor is rotated in the opposite direction until final engagement is made.

Note : Avoid trapping of fingers when the unit is engaged under spring pressure.



OPERATION

SECTION 4

4.6 SETTING THE CLEARANCE ANGLE

For most cutters the clearance angle can be set by eye. i.e. by setting the back face of the knife parallel with the face of the wheel. If this is done the grinding operation will reproduce the same clearance angle. If more accurate setting of the clearance angle is required, a scale [1] (Fig. 4f) and setting chart (Fig. 4e) are provided.

To set the clearance angle first determine the cutting diameter of the cutterhead to be ground. Find this point on the horizontal axis of the setting chart. Trace vertically up until the line is met which represents the required clearance angle. At this position trace back horizontally to the vertical axis on the setting chart. This gives a scale reading which corresponds to the setting to be made on the scale on the grinding head.

Example :

180 diameter cutterhead, 25 degree clearance angle. Scale reading required is 4.2.

Note : The chart shown below is for the No. 4 knife guide. If other knife guides are used, see alternative charts in Appendix A7

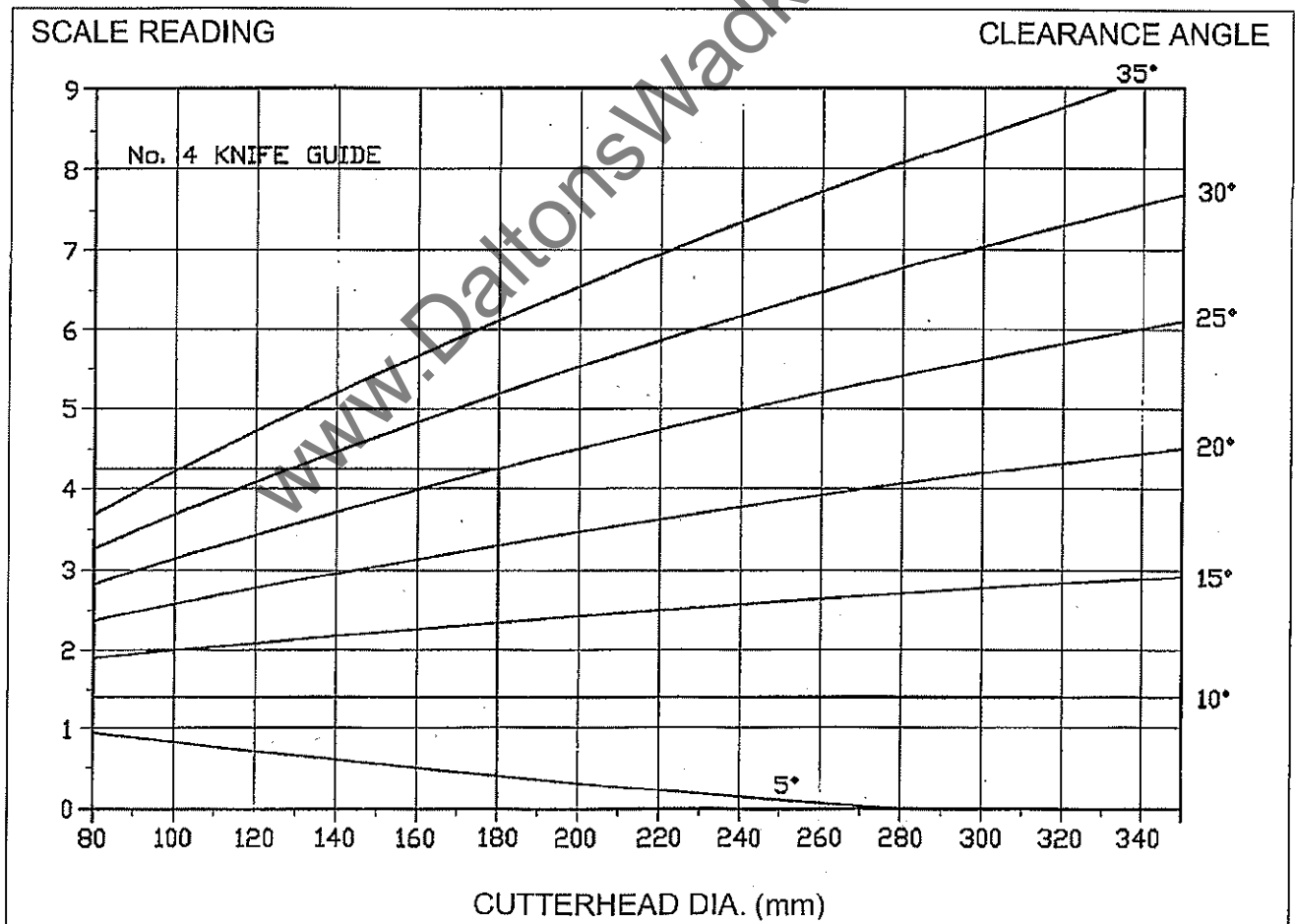

Fig. 4e Clearance angle chart for No.4 knife guide



4.7 GRINDING HEAD ADJUSTMENT

Before the table is moved it is essential to move the grinding head back to avoid any foul conditions.

Using the handwheel [4] at the front of the machine, the head should be moved back until the wheel and knife guide are well clear of the path of the cutters. The table can then be moved to bring the cutter to the knife guide.

The height of the head (clearance angle) is set by releasing the lock [2] and adjusting the top handwheel [3]. The scale [1] indicates the clearance angle set. Note : the planerhead should be free to rotate on the arbor whilst the head position is set.

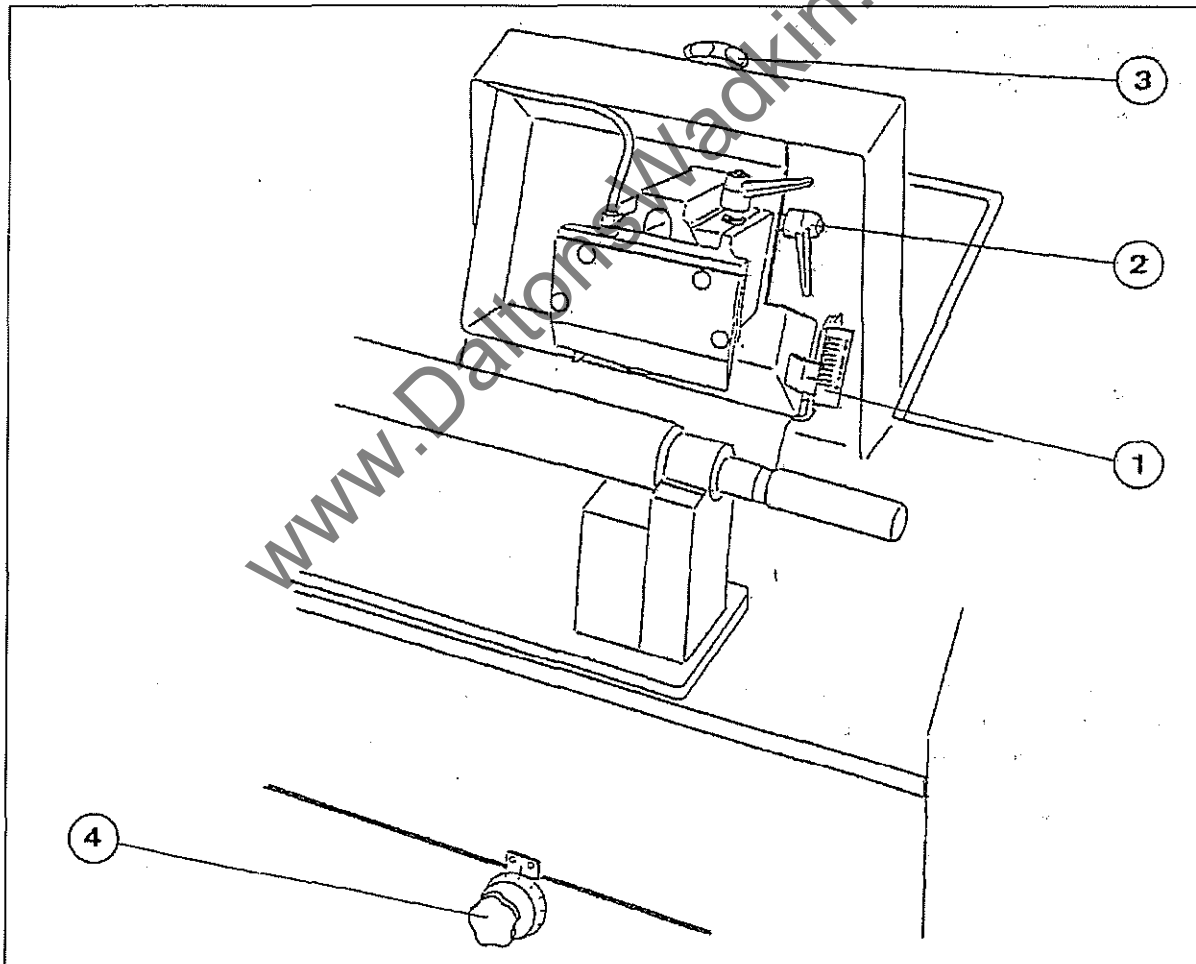

Fig. 4f Head adjustments



OPERATION

SECTION 4

The height of the head and the in / out position are set such that the knife can be located under the knife guide as shown in *Fig. 4g*.

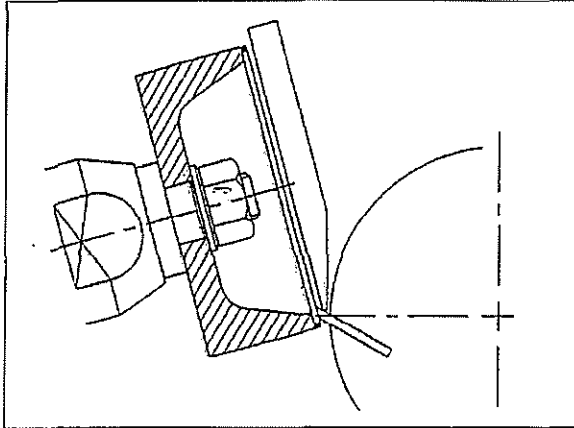

Fig. 4g

The knife guide has a grinding point [1] and two angles along the bottom edge (*Fig. 4h*). The knife should be located on the grinding point when final setting is carried out.

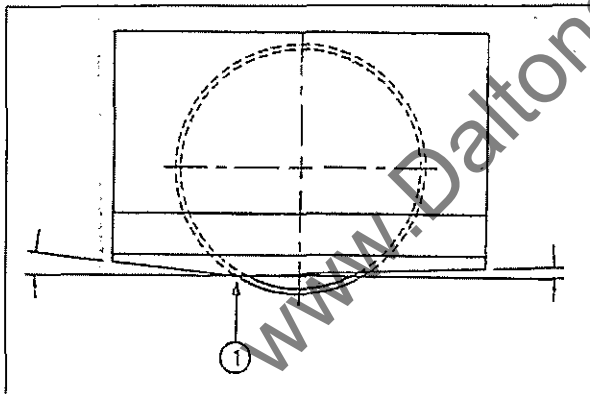

Fig. 4h

The knife is set to lightly touch the face of the grinding wheel and then backed off one graduation on the adjustment screw [4] such that the knife is free to pass across the face of the wheel. This position is best gauged when the wheel is rotated by hand.

The crank handle should be removed when head adjustment is complete.

4.8 KNIFE PRELOAD

A torsion spring is incorporated in the indexing unit to ensure that the knife is kept in contact with the knife guide during the grinding operation. The 'lead-in' angle on the bottom edge of the knife guide is used to engage the knife and to rotate the planerhead slightly against the spring before reaching the grinding point [1].

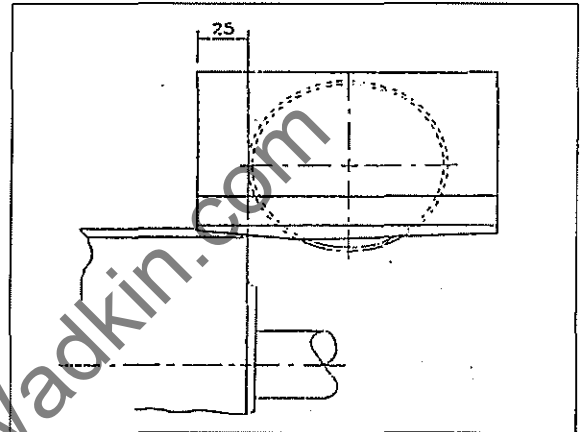

Fig. 4i

The table should be moved to position the knife approximately 25 mm (1") onto the knife guide (*Fig. 4i*). At this point the planerhead should be locked onto the arbor whilst the knife is touching the knife guide. Carefully check by left / right table movements that the knife engages and passes the grinding point correctly.



OPERATION

SECTION 4

4.9 TABLE TRAVERSE LIMITS

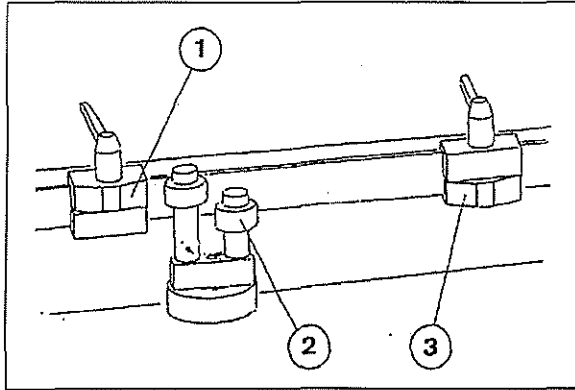

Fig. 4j

The indexing position should be set by moving the table to the left until the planerhead is approximately 20 mm (3/4") clear of the knife guide (i.e. free to rotate). The cam [3] should then be set to operate the roller [2] at this position.

The other cam [1] should be set to operate the roller when the trailing edge of the knife is approximately 10 mm (3/8") past the centre line of the grinding wheel.

Note : Do not allow the knife to leave the knife guide on the right.

When the traverse limits are set, the table should be moved to the park position using the "PARK" control, in preparation for auto-cycle grinding.

4.10 COOLANT APPLICATION

The coolant flow control tap is located inside the main tray to the left of the grinding head. Ensure that it is in the open position by turning the tap handle to bring it in line with the coolant pipe.

Also ensure that the free end of the coolant pipe is located in the top of the wheel guard. Note : The free end of the coolant pipe locates in a push on fitting and can be released by pressing the collet of the fitting down whilst gently pulling the pipe away from the wheel guard.

Always use copious amounts of coolant when grinding with C.B.N. and diamond wheels. It has the effect of prolonging wheel life, improving finish and settles grinding dust.



OPERATION

SECTION 4

4.11 SETTING GRINDING PARAMETERS

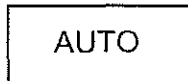

Press AUTO button.

Display :-

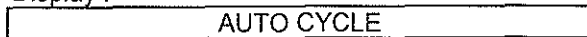

The display screen will show the message "AUTO CYCLE". If the guard is open a message "CLOSE GUARD" will be displayed. The machine is disabled and the message will stay on the screen until the guard is closed, and kept closed. If the machine table is not in the PARK position a message "PARK TABLE" will be shown on the display screen. Press and hold the "PARK" button until the table reaches the PARK position. If the table is already in the PARK position the next stage of auto-cycle is automatically initiated.

Display :-

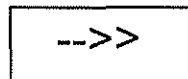
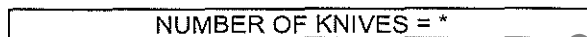

Button increases number of knives (*) by 2.



Button decreases number of knives (*) by 2.

The maximum number of knives capable of being ground is 30. When this figure is reached the setting will automatically reset to 2 at the next press of the push-button. When the operator is satisfied that the figure shown on the display corresponds to the actual number of knives in the cutterhead, push-button "KNIVES" is pressed to accept the figure.



Button sets number of knives

Display :-

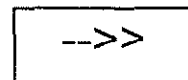
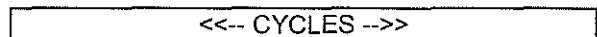

Button increases number of cycles (*) by 1.



Button decreases number of cycles (*) by 1.

"Cycle" means one revolution of the cutterhead and refers to the roughing cut cycle. The operator is able to select the number of roughing cycles that are required, the maximum number of cycles is set at 5 roughing cycles. The programmable controller will automatically add 1 finishing grind cycle and spark-out cycle, e.g. if the operator selects 3 roughing cycles, the programmable controller will add 1 finish cycle and 1 spark-out cycle to make a total of 5 cycles.



Button sets number of cycles.

Display :-

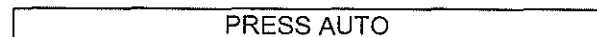

At this point the operator has the choice of starting the grinding cycle or setting the depths of cut for the roughing and finishing cut. If the operator elects to start the grinding cycle the depths of cut used are those stored in the programmable controller from the last cutterhead ground.

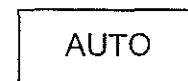

Button starts grinding operation (see 4.12)



OPERATION

SECTION 4

INFEED

Button allows depth of cut to be set

Display :-

SET ROUGH CUT

ROUGH CUT = *

<<-- INFEED -->>

-->>

Button increases depth of roughing cut (*) by 0.02 mm.

<<--

Button decreases depth of roughing cut (*) by 0.02 mm.

The maximum depth of roughing cut allowable is 0.10 mm (0.004") and a minimum depth of roughing cut 0.02 mm (0.0008").

INFEED

Button sets depth of roughing cut.

SET FINISH CUT

FINISH CUT = *

<<-- INFEED -->>

-->>

Button increases depth of finishing cut (*) by 0.01 mm.

<<--

Button decreases depth of finishing cut (*) by 0.01 mm.

The maximum depth of finishing cut allowable is 0.02 mm (0.0008") and a minimum depth of finishing cut 0.00 mm.

INFEED

Button sets depth of finishing cut.

Display :-

MACHINE SET ?

PRESS AUTO

AUTO

Button starts grinding operation.

Display :-



OPERATION

SECTION 4

4.12 AUTO CYCLE GRINDING

Select the required table traverse speed with rotary control knob on the control panel and press "AUTO".

Display :-

ROUGHING CUT 1

The grinding wheel and coolant pump will automatically start. The grinding head will automatically increment to give the required depth of roughing cut.

Note : At this point numerous 'clicks' will be heard and the handwheel on the front of the machine will move. This is the mechanism that moves the head working. The table will move and the first roughing cut will take place.

Display :-

FINISH GRINDING

When all roughing cut cycles are complete the finish cut cycle will commence and a message "FINISH GRINDING" will be on the display. The head will feed the selected amount and the table will traverse right to begin the first finish cut.

Display :-

SPARKING OUT

When the finish cut cycle is complete the cutterhead will commence its sparking out cycle. There is no increment of the head. A message "SPARKING OUT" will be on the display.

Display :-

GRIND COMPLETE

At the end of the auto cycle the message "GRIND COMPLETE" will be on the display, the coolant and grinding wheel will switch off and the table will move to the park position. The display will show the message "MANUAL CONTROL". The machine is now back in manual control mode. The cutterhead can be unloaded and the machine is ready to accept the next cutterhead.

Display :-

MANUAL CONTROL

4.13 INTERRUPTION OF AUTO CYCLE

NOTE : DO NOT INTERRUPT AUTO CYCLE BY LIFTING THE GUARD. THIS WILL AUTOMATICALLY STOP AND RESET THE MACHINE. ALL SETTINGS WILL BE DROPPED AND THE COMPLETE MACHINE SET-UP PROCEDURE WILL HAVE TO BE REPEATED.

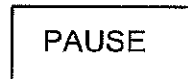

Button will interrupt auto cycle.

Display :-

AUTO PAUSE

If during the grinding cycle any changes need to be made, e.g. table travel limits, coolant flow increase, the "PAUSE" push-button, when pressed, will temporarily suspend operation of the machine. The machine will carry on until the table next reaches its left hand position, i.e. index position. The display will show a message "AUTO PAUSE". The guard can now be opened and the required alterations made. The display will show a message "CLOSE GUARD". At this point none of the push-buttons on the control panel are active.

Display :-

CLOSE GUARD

Once all alterations have been made, the guard should be closed. To continue the cycle the "PAUSE" push-button should be pressed, the auto cycle will resume.

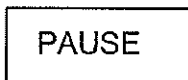

Button will re-start auto cycle.



OPERATION

SECTION 4

4.14 DEPTH OF CUT ALTERATION

At any time during the grinding cycle the depth of cut can be altered manually using the head adjustment handwheel (4) (fig. 4f). This can be done during the cycle and is preferably made when the cutterhead is being indexed and the grinding wheel is not in contact with the knife.

NOTE : EACH DIVISION ON HANDWHEEL
= 0.02 mm (0.0008")

Take care to only add a small amount. Excessive movement of the handwheel could result in damage to the machine.

4.15 FEED RATE ALTERATION

After the last cut on the final roughing cycle and before the start of the finishing cut cycle, (when the cutterhead is being indexed) it is advisable to alter the traverse rate of the table. As a rough guide the finish cut traverse rate should be approximately half that of the roughing cut traverse rate.

The feed speed can be altered at any time using the knob on the control panel.

4.16 CLEARANCE ANGLE GAUGE (Optional extra)

An optional extra clearance angle setting gauge is available from Wadkin (see Appendix A5). This can make the setting of the grinding head easier and can also be used to measure the angle of ground cutters.

SETTING CLEARANCE ANGLE

- 1) Put table into park position.
- 2) Set scale to the required clearance angle.
- 3) On the right hand end of the arbor a mounting diameter is provided for the angle setting gauge. Mount the setting gauge on the machine arbor.
- 4) Set radius on the setting gauge, i.e. point 'B' in line with the knife tip.
- 5) Adjust head position (2 axes, i.e. grinding head in / out and height positions) to set the gauge so that the face of the knife guide contacts face 'C' and the knife guide tip touches point 'B'.

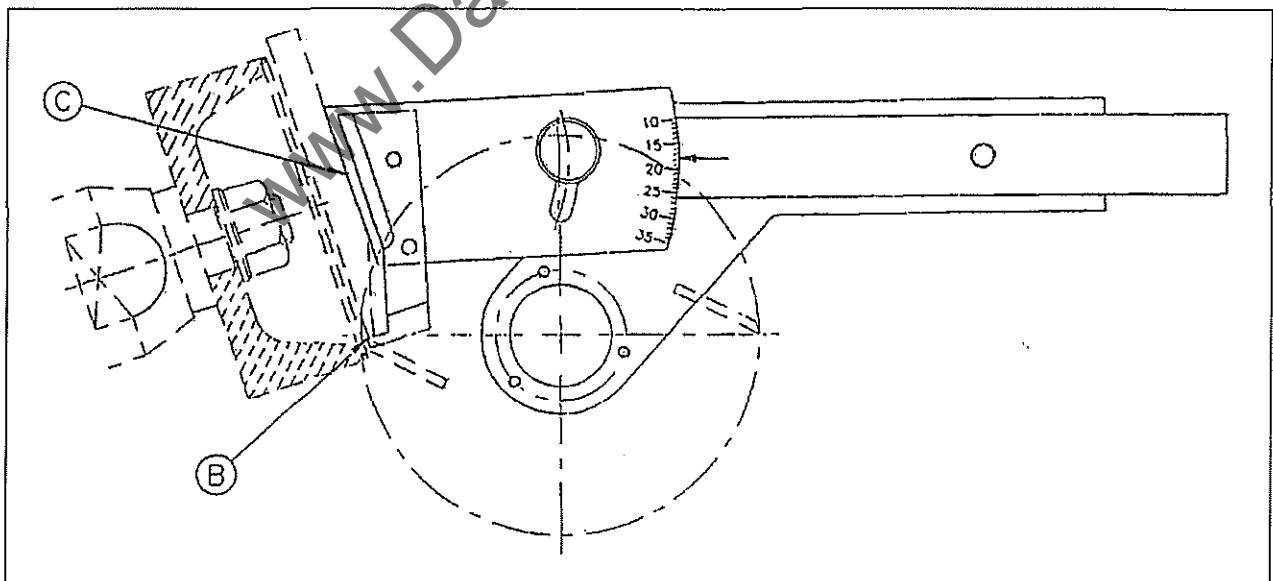

Fig. 4k Clearance angle gauge



OPERATION

SECTION 4

4.17 CARE OF THE MACHINE

MEASURING CLEARANCE ANGLE

With the head still set in the last grind position, the angle setting gauge can be used to determine the clearance angle ground on a planerhead.

- 1) With the head still set in the last grind position and the table in the park position, mount gauge on arbor.
- 2) Unlock both axes on gauge and locate points 'B' and 'C' on to knife guide. Lock axes.
- 3) Read clearance angle from gauge.

The machine should be cleaned down when grinding is finished. The abrasive dust produced by the grinding operation can cause damage to moving parts and slideways if cleaning is not carried out correctly.

COMPRESSED AIR SHOULD NOT BE USED

to assist cleaning. It can cause abrasive dust and coolant to be forced into slides, screws and bearing surfaces. It can also be dangerous to other people.

A flow of coolant can be used to wash the machine but ONLY ON THE AREAS WHERE COOLANT NORMALLY FLOWS during grinding. If a coolant flow is used, the following guidelines must be observed -

- Coolant must not be sprayed onto electric motors. These are splashproof but are not designed to withstand constant jets of coolant.
- Coolant must not be sprayed under covers or into slides, screws, bearings etc.
- Coolant should not be used to simply wash all the grinding debris down into the tank - this only leads to more frequent cleaning of the tank and filtration system.

NZ350 machines are provided with an additional washdown facility :- A coiled pipe and tap [6] (Fig 3a) are located at the rear of the main tray above the coolant tank. With the tap [6] turned and the coolant pump started, the pipe can be used to wash down the machine.

Accumulations of grinding debris should be scooped out of the coolant trays. It is a matter of personal choice as to whether this is better done with the debris wet or dry.

The metal filtration magnets and weir filter trays should be cleaned out regularly as described in section 5.

The level of coolant in the system should be 'topped up' as necessary. (See Appendix A2.) A level indicator is fitted to the coolant tank. The coolant should be allowed time to drain into the tank before the reading is taken. Note : Different types of coolant fluid should not be mixed together, see maintenance section 5.



MAINTENANCE

SECTION 5

SECTION 5 : MAINTENANCE

5.1 SAFETY

The machine should always be electrically isolated when maintenance is carried out unless specifically required otherwise.

Maintenance personnel should be familiar with the Health and Safety precautions for handling coolant fluids. See Appendices A2 and A3.

5.2 CLEANING THE MACHINE

Cleaning should be carried out on a regular basis as part of the normal operation of the machine (see section 4.17). During machine maintenance any shortcomings should be made good by thorough cleaning.

COMPRESSED AIR SHOULD NOT BE USED ...

for cleaning the machine. It can cause the abrasive dust and grit produced during grinding to be forced into slides, screws and bearings etc. A flow of coolant can be used to wash the machine but **ONLY ON THE AREAS WHERE COOLANT NORMALLY FLOWS.** (See section 4.17).

5.3 LUBRICATION

The machine is designed to require minimum lubrication. The grinding spindles, motors, coolant pump and carriage slideways are fitted with sealed bearings which require no additional lubrication.

On a monthly basis the table drive should be lubricated. Two lubrication points are provided for this purpose.

One shot of grease (Wadkin L6) should be applied to the drive shaft bearing at point [1].

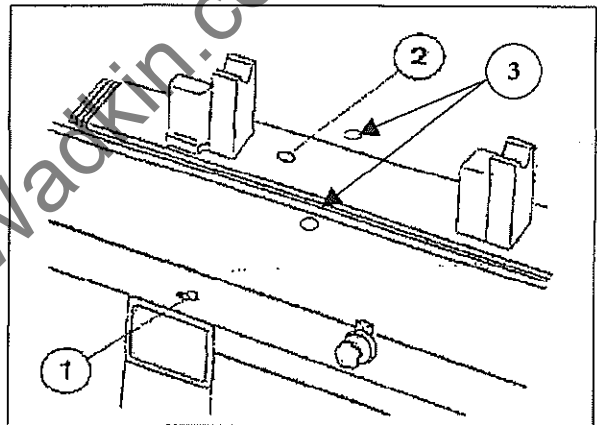

Fig. 5a Table drive lubrication

The cap [2] should be unscrewed using a 5 mm A/F allen key to reveal the greasing point for the table drive mechanism. Only one shot of grease should be applied. Note : Over-greasing can cause slippage problems with the table.

The NZ350 only is fitted with two additional greasing points [3] for the carriage slideways. On a monthly basis the plastic dust caps should be removed and one shot of grease applied to each. Replace caps after greasing.

All bushes employed are of the 'bronze oil retaining type'. Slides and screws should be examined periodically with careful attention paid to any moving parts that become stiff.

Accessible slides, screws, bushes etc. should be lubricated weekly with Wadkin grade L4 oil. A list of approved lubricants is given in Appendix A1.



5.4 WHEEL MOUNTING AND GUARD

It is essential for the safe operation of this machine that the wheel mounting and wheel guard are maintained in good condition. The grinding spindle end should run true and be free from burrs. The spindle nut should be in good condition.

The wheel guard and knife guide including their fixings should be in good condition.

These items should be checked whenever wheels are mounted and if worn or damaged they should be replaced.

5.5 COOLANT SYSTEM

The useful life of the coolant mixture is dependent on various factors such as the amount of use, type of fluid etc. The frequency of maintenance times are given only as a general guide. Always allow time for the coolant system to drain down before maintenance to avoid leakage.

1 - 2 weeks :

Open the weir filter tray [2] as illustrated. Do not open too far. It is only necessary to allow access to the lift out weir section [3]. Remove the two metal filtration magnets [5] and clean. Note : The magnets are very strong and care should be taken to ensure that fingers are not 'nipped' when replacing them.

Remove the lift out weir tray [3] and clean out. Brush any grinding debris from the perforated filter section. Clean any debris from the weir filter tray [2] and re-assemble.

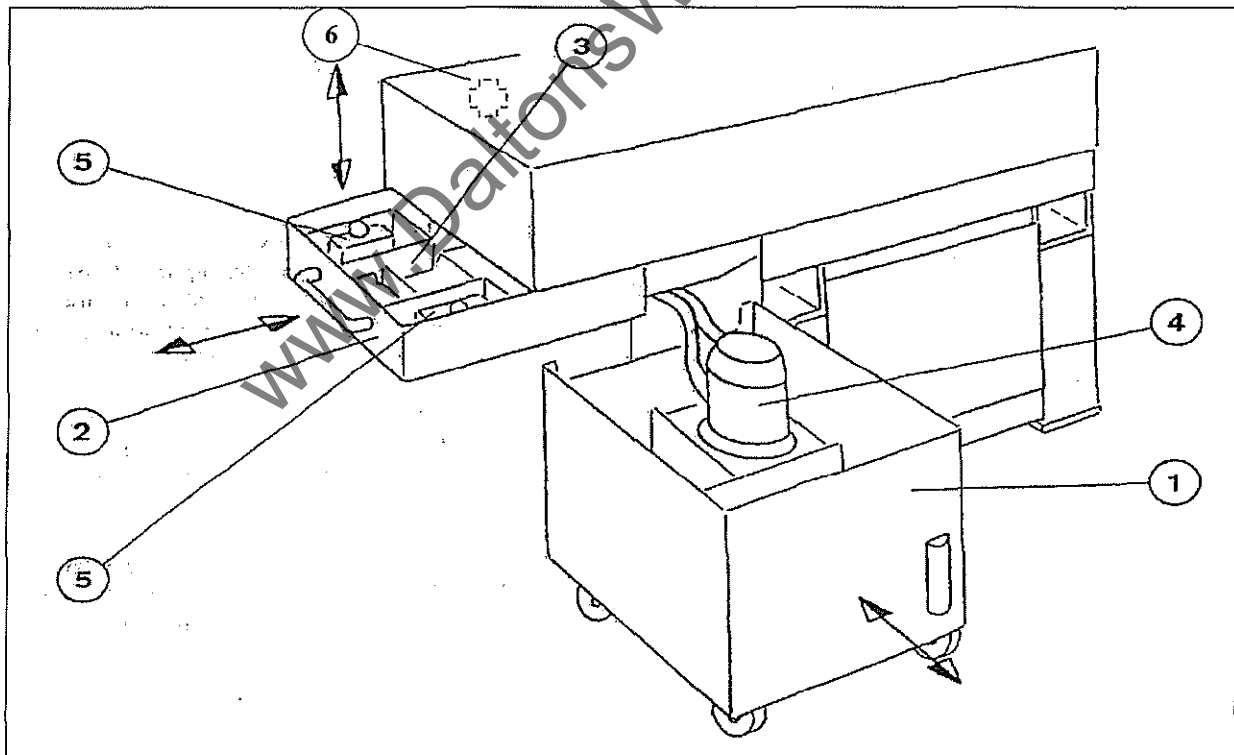

Fig. 5b



MAINTENANCE

SECTION 5

1 - 2 months :

Topping up of the coolant system and evaporation over a period of time can affect the dilution of the mixture. This should be checked using a refractometer, which can be supplied by Wadkin (see Appendix A5). The mixture should be checked and corrected if necessary. (See Appendix A2.)

4 - 6 months :

The machine should be thoroughly cleaned down and the coolant replaced. If the machine is provided with a washdown facility it can also be used to pump out the coolant fluid from the tank. The end of the pipe should be placed in a bucket or other suitable container, the tap [6] (fig 3a) switched over and the COOLANT pump started. NOTE :- Take care not to pump sediment.

The tank [1] can be pulled out towards the front of the machine far enough to allow the pump assembly [4] to be lifted out. The tank is then free to be wheeled away and the coolant disposed of as per Appendix A2. The tank and weir filter trays should be cleaned out before the system is refilled.

The system should be cleansed with an anti-bacterial cleaning fluid when required. Details of the anti-bacterial solution supplied by Wadkin are given in Appendix A3.

Important : If coolant fluids are used other than those supplied by Wadkin, the Health and Safety

recommendations supplied with the fluid should be strictly followed.

Different types of coolant fluid should not be mixed together. When changing supply, the system should be thoroughly drained and cleaned before refilling with the new coolant.

5.6 ELECTRICAL SYSTEM

All electrical maintenance work should be carried out by a competent electrician.

The electrical circuit diagram is included at the end of this manual - see Appendix A7. A copy of the circuit diagram for the machine together with separate instruction manuals and wiring diagrams for the inverter (variable speed unit) and P.L.C. control unit should be enclosed with the machine documentation inside the electrical control cabinet.

Routine maintenance of the electrical system is not necessary other than to check the condition of the controls and worklamp. Any damaged control buttons etc. or defective bulbs should be replaced.



MAINTENANCE

SECTION 5

5.7 FAULT FINDING

Listed below are some faults which may develop from time to time. This list is only representative of what may happen and cannot include every eventuality.

FAULT	POSSIBLE CAUSE	REMEDY
Table will not move.	Table drive belt broken	Replace
	Speed control knob set too low	Select higher speed
	Drive shaft over lubricated	Clean drive shaft
	Fuse blown controlling speed inverter	Check and replace 5 amp fuse (T30 17187) in middle fuse holder on LH panel
No coolant flow	Tank level too low	Top up coolant tank
	Coolant tap incorrectly set	Check that handle on coolant tap is in-line with output pipe
	Blocked pipes	Check for blockage and clear
	Coolant pump filter blocked	Remove pump and clear blocked filter plate
Pushbutton malfunction	Blown fuse	Check 5 amp fuse in bottom fuse holder on LH panel. Replace (T30 17187).
Power indicator malfunction	Blown fuse	Check and replace 5 amp fuse in bottom fuse holder on LH panel (T30 17187).
	Blown bulb	Replace bulb (T30 17220)
Message display malfunction	Blown fuse	Check and replace 1 amp fuse in top fuse holder on LH panel (T30 17171).
	Programmable controller malfunction	See 'Failed processor start-up'
Index unit malfunction	Blown fuse	Check and relace 5 amp fuse in bottom fuse holder on LH panel (T30 17187).



MAINTENANCE

SECTION 5

FAULT	POSSIBLE CAUSE	REMEDY
Failed processor start up	Master control relay fuses blown	Check and replace fuse(s) in second and third fuse holder on LH panel (T30 17187)
	Programmable controller fuse blown	See P.L.C. manual supplied with machine
	P.L.C. fuse blown	Check fuse holder in RH panel and replace. 5 amp fuse (T30 17187).
	Ambient temperature below 0 deg. C.	Check ambient temperature is above 0 deg.C. If not use a gentle heat source to gradually raise the temperature.
Limit switches fail to operate	Mechanical failure	Replace
	Blown fuse	Check 5 amp fuse in bottom fuse holder on LH panel and replace (T30 17187).
Total machine failure	Blown fuse - cabinet isolator	Examine and replace 20 amp fuse(s) on cabinet isolator
	Blown fuse - customer fuse box	Examine and replace as necessary
	Power cut	Wait until power restored

5.8 MACHINE ALIGNMENTS

There are a number of alignments and checks which are built into the machine from new and **MUST** be re-set whenever parts are dismantled and re-built. The following alignments should be set by a competent engineer.



MAINTENANCE

SECTION 5

Test No.	Test diagram	Test	Permissible Error mm / inch
----------	--------------	------	--------------------------------

CARRIAGE

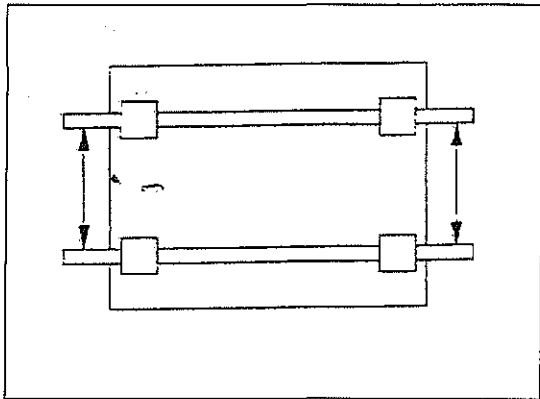

Set carriage bearings parallel

0.0125 / 0.0005

1

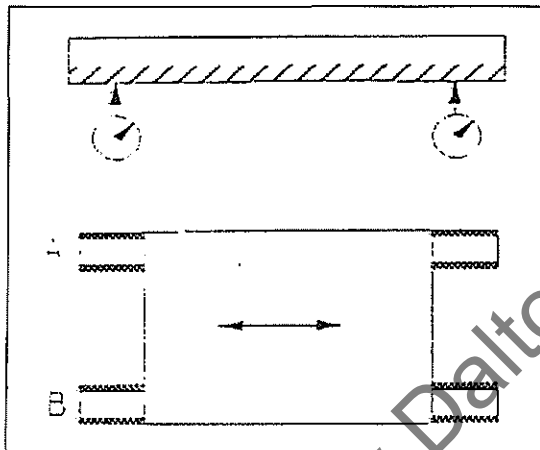

Set rail A parallel to straight edge using carriage movement

0.03 / 0.0012

Set rail B parallel to rail A

0.0125 / 0.0005

2

HEADSLIDE

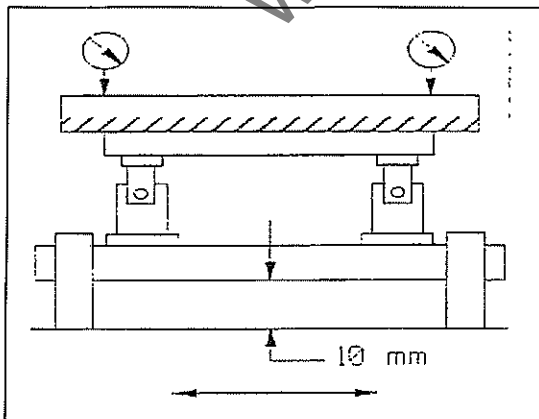

Position head on 10 mm strips to nominal dimension.

With clock set on carriage set straight edge parallel to carriage movement.

0.10 / 0.004

3



MAINTENANCE

SECTION 5

Test No.	Test diagram	Test	Permissible Error mm / inch
----------	--------------	------	--------------------------------

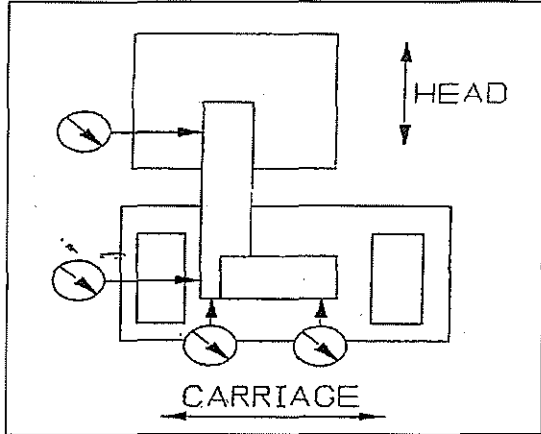

Set heel of square parallel to carriage movement.

With clock on head set head square along head movement 0.10 / 0.004

4

INDEXING UNIT / ARBOR SUPPORTS

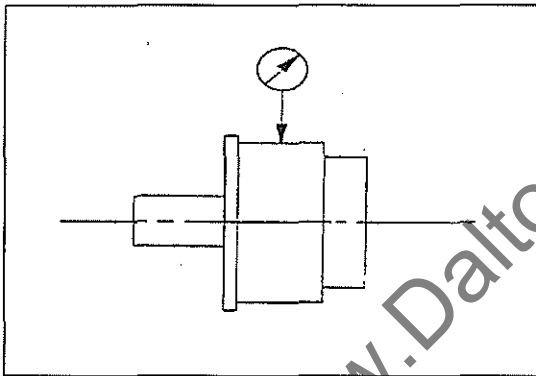

Set indexer end cap concentric with drive shaft

0.01 / 0.0004

5

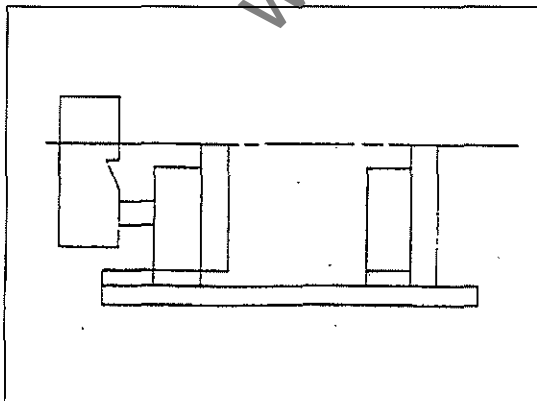

Set test arbor parallel in both planes to carriage movement, and on centre line of indexer 0.01 / 0.0004

6



MAINTENANCE

SECTION 5

Test No.	Test diagram	Test	Permissible Error mm / inch
7		Test arbor should be feeler tight in arbor supports. Bed in.	--- / ---

8		Fit arbor and check run out using indexer.	0.01 / 0.0004
---	--	--	---------------

8

SPINDLE UNIT

9		Check spindle run out.	
		At A	0.0125 / 0.0005
		At B	0.0125 / 0.0005

9

10		Set spindle to carriage movement	--- / ---
		Dowel head in position	--- / ---
		A = 0	--- / ---
		B = -0.20 / -0.30	--- / ---

10



MAINTENANCE

SECTION 5

Test No.	Test diagram	Test	Permissible Error mm / inch
----------	--------------	------	--------------------------------

KNIFE GUIDE

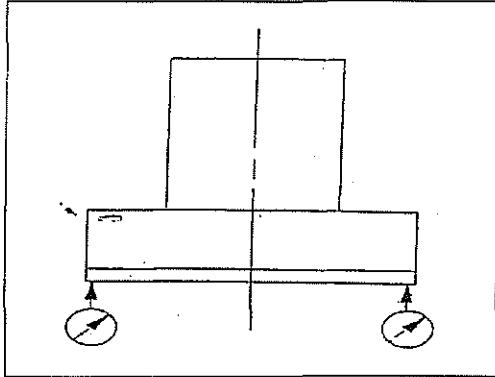

Set knife guide parallel to carriage movement.

0.025 / 0.001

11

OTHER SETTINGS

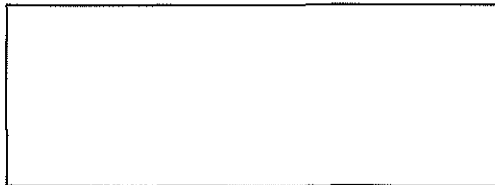

Set infeed mechanism

-- / ---

Adjust until mechanism moves head 0.01 mm per operation.

12



Adjust inverter for :

- Low speed (0 m/min at 0)
- High speed (3 m/min at 10)
- Ramp up Even take up of table power
- Ramp down Slow and even stop of table (no jerk).

13

TEST EQUIPMENT

Some of the tests involve the use of special test equipment which can be supplied by Wadkin if required.

Part No.	Description	For test no.
NHP 464	Test arbor	6, 7



SECTION 6 : ILLUSTRATED PARTS LIST

Should it become necessary to replace worn or damaged parts of the machine, it is essential that the work is carried out by a competent engineer in order to maintain the grinding accuracy of the machine. Alignments MUST be re-set as described in section 5.8.

Always quote the Machine No. and Test No. when ordering spare parts from Wadkin. This information is marked on the machine nameplate.

www.DaltonsWadkin.com



PARTS LISTS

SECTION 6

Fig. 6a Table Assembly (NZ 300)

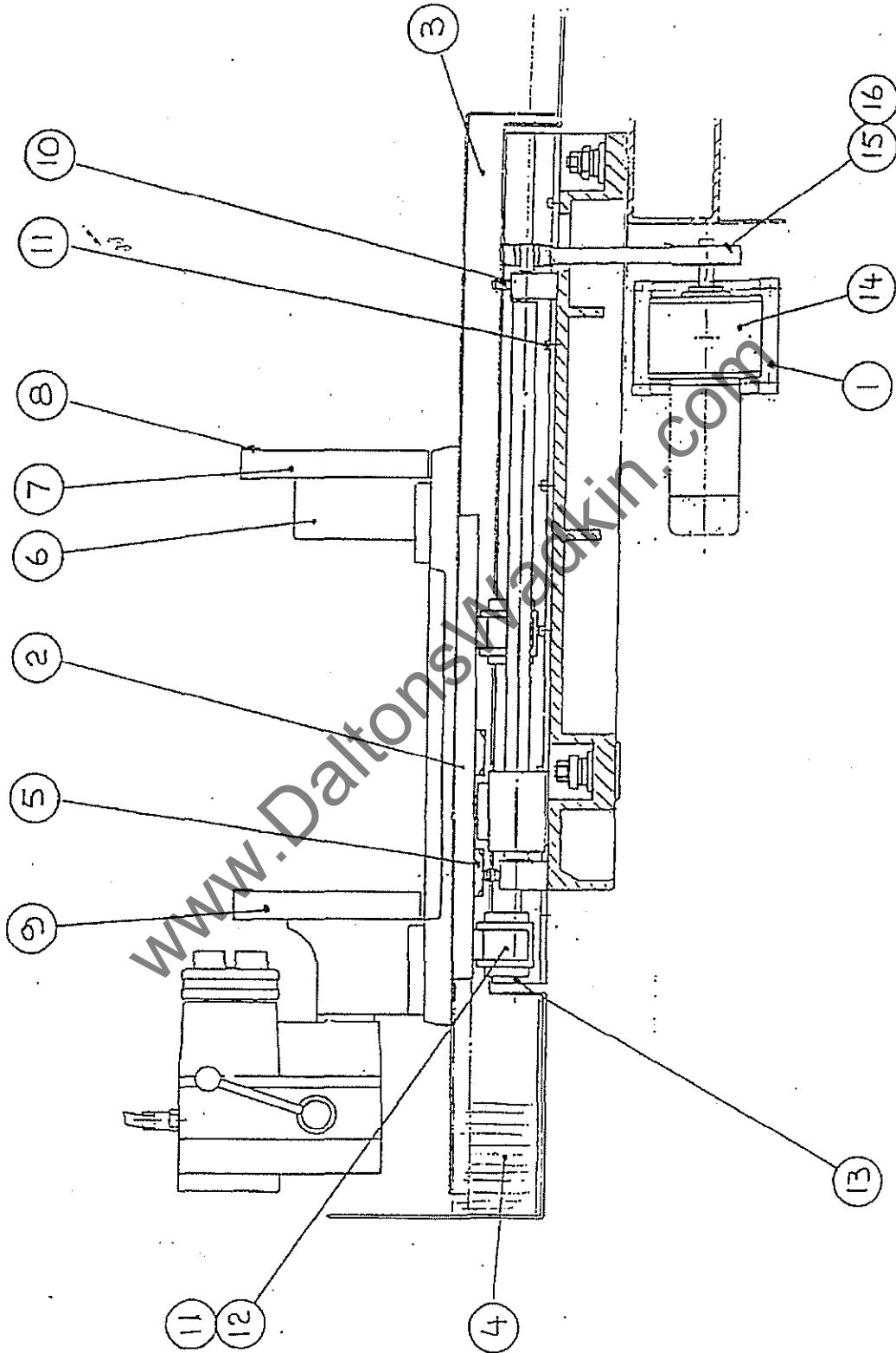



PARTS LISTS

SECTION 6

TABLE ASSEMBLY (NZ 300) (Fig. 6a)

<u>ITEM</u>	<u>QTY</u>	<u>PART No.</u>	<u>DESCRIPTION</u>
1	1	NHP 205	Mount plate for STM motor
2	1	NHP 208	Carriage plate
3	1	NHP 209	Carriage cover
4	1	NHP 210	Carriage bellows
5	2	NHP 218	Cam plate for limits
6	1	NHP 303	Arbor support
7	1	NHP 329	Arbor post RH
8	1	NHP 346	Arbor shell
9	1	NHP 347	Arbor post LH
10	2	NXUS0033	Limit switch
11	32	T0525167	Hex skt capscrew M6 x 25 mm
12	4	T3005347	Linear bearing and housing
13	2	T3005348	Support rail TSWW 30 x 900
14	3	T3051110	MCP 63 6:1 gearbox
15	1	T3077104	Timing pulley - 043F0044
16	1	T3077539	Taper lock bush

NOTE : SEE Fig 6m FOR NZ 350 TABLE ASSEMBLY



PARTS LISTS

SECTION 6

Fig. 6b Table drive

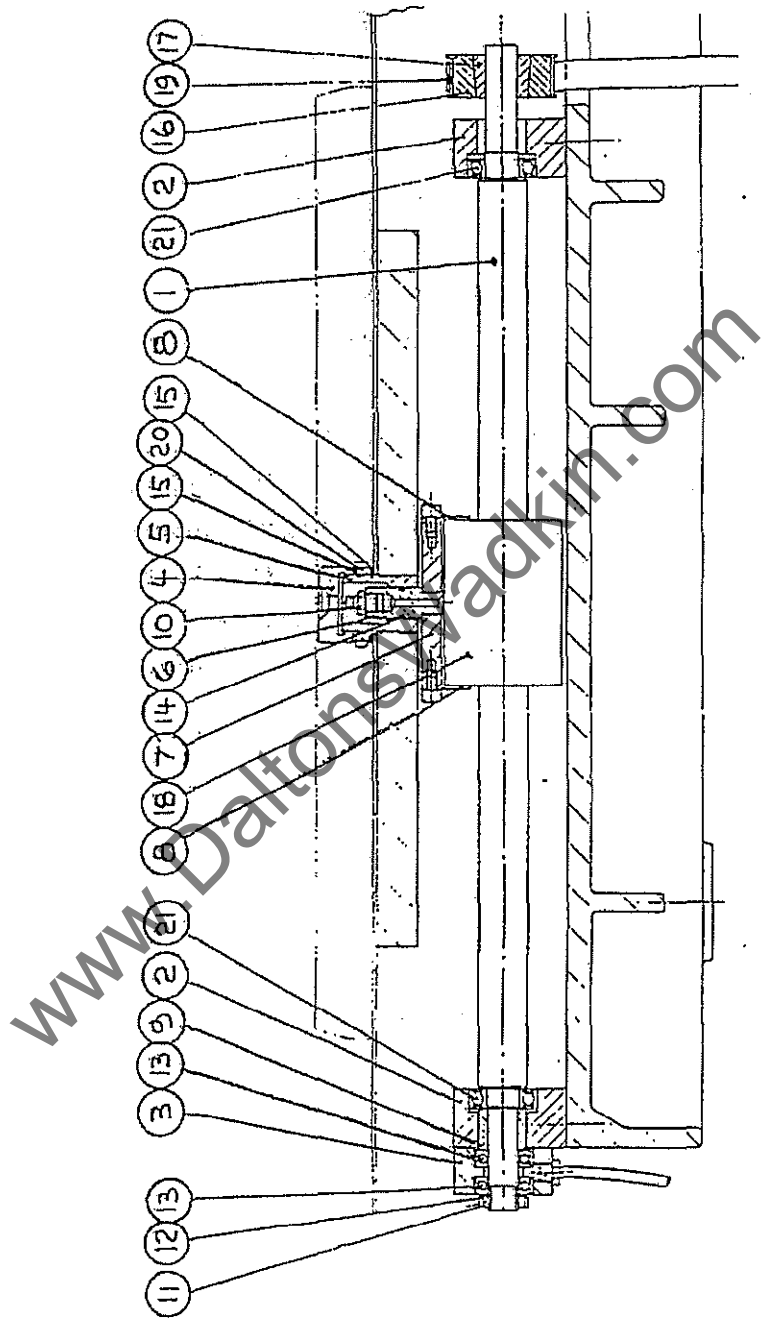



PARTS LISTS

SECTION 6

TABLE DRIVE (Fig. 6b)

<u>ITEM</u>	<u>QTY</u>	<u>PART No.</u>	<u>DESCRIPTION</u>
1	1	NHP 231	Drive shaft for carriage
2	2	NHP 233	Drive shaft mounting
3	1	NHP 234	Thrust bearing housing
4	1	NHP 236	Cap for drive nut connect
5	1	NHP 237	Sleeve for drive nut conv.
6	1	NHP 238	Connecting pin for drive
7	1	NHP 239	Connecting plate for drive
8	2	NHP 240	Grease guide
9	1	NHP 241	Bearing spacer for driveshaft
10	1	T0950104	HP2 grease nipple 1/8" BSP
11	1	T3005318	SKF lock nut M15 x 1 ref: KM2
12	1	T3005319	SKF locking washer M15
13	2	T3005321	SKF thrust bearing ref : 51102
14	1	T3069116	O' ring GACO RMO116-24
15	2	T3073211	Dowty bonded seal M30
16	1	T3077102	Timing pulley - 043F0034
17	1	T3077103	Taper lock bush - 1008
18	1	T3077354	Uhing linear drive nut
19	1	T3077355	Timing belt 128 tooth
20	1	K0527207	Notch nut M30 x 1.5
21	2	K0601120	6003-2RS RHP & SKF bearing



PARTS LISTS

SECTION 6

Fig. 6c Table traverse limits

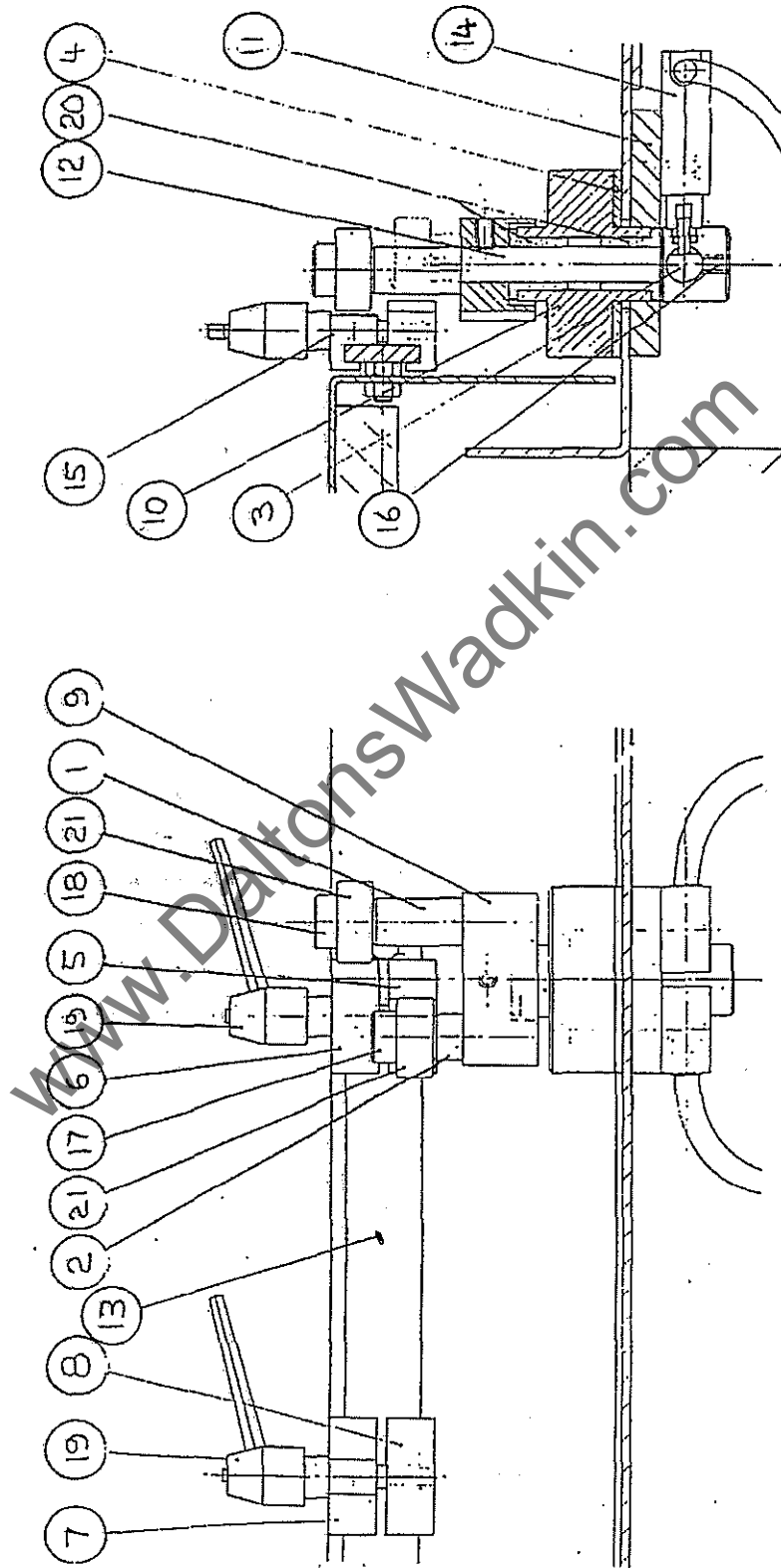



PARTS LISTS

SECTION 6

TABLE TRAVERSE LIMITS (Fig. 6c)

<u>ITEM</u>	<u>QTY</u>	<u>PART No.</u>	<u>DESCRIPTION</u>
1	1	NHP 214	Spacer
2	1	NHP 215	Spacer
3	1	NHP 216	Actuator
4	1	NHP 217	Gasket
5	1	NHP 220	Bottom cam
6	1	NHP 221	Clamp
7	1	NHP 222	Top cam
8	1	NHP 223	Clamp
9	1	NHP 224	Pivot bar
10	1	NHP 225	Boss
11	1	NHP 226	Mounting bar
12	1	NHP 227	Pivot pin
13	1	NHP 228	Cam bar
14	2	NXUS0033	Limit switch
15	2	T0526244	Screwed stud M8 x 80 mm
16	1	T0526611	Hex skt screw cp M6 x 12 mm
17	1	T3073141	Shoulder screw
18	1	T3073142	Shoulder screw
19	2	K0530241	Ratchet lock handle M8 x 12.5
20	2	K0531347	24 FI bush 12 b x 18 od x 20 lg
21	2	K0601316	SKF 63001-2RS bearing



PARTS LISTS

SECTION 6

INDEXING UNIT (Fig. 6d).

<u>ITEM</u>	<u>QTY</u>	<u>PART No.</u>	<u>DESCRIPTION</u>
1	1	NHP 304	Index unit / arbor support
2	1	NHP 313	Inner jaw shaft
3	1	NHP 314	Pivot shaft
4	1	NHP 316	Trunnion
5	1	NHP 317	Spring plate
6	1	NHP 318	Location collar
7	1	NHP 319	Housing
8	1	NHP 320	Motor housing
9	1	NHP 321	Motor cover
10	1	NHP 322	Spring jaw flange
11	1	NHP 323	Spring jaw
12	1	NHP 324	Gearbox mounting
13	1	NHP 325	Motor mounting
14	1	NHP 326	Bearing shoulder
15	1	NHP 327	Bearing spacer
16	1	NHP 335	Torsion spring
17	2	NHP 343	Compression spring
18	1	NHP 330	Location pin
19	1	NHP 331	Stop pin
20	1	NHP 352	Spacing ring for spring
21	1	T3005113	Bush 25 ID x 32 OD x 25 lg
22	2	T3005114	Bush 30 ID x 38 OD x 25 lg
23	1	T3005125	30 Fl Glybush 20 ID x 23 OD x 15 lg
24	1	T3017166	Stepper motor type 34
25	1	T3025206	Harmonic drive gear set
26	1	T3073208	Shamban excluder
27	1	T3089105	Tab washer M45
28	2	K0527205	Notch nut M20 x 1.5
29	1	K0527210	Notch nut 45 mm x 1.5
30	2	K0527254	Tab lock washer 20 mm bore
31	1	K0528107	Washer 20 mm
32	2	K0601151	6009-2RS RHP & SKF bearing
33	1	K3009278	External circlip 50 mm dia.
34	1	K0531359	39 Fl bush 25 b x 32 OD x 25 lg



PARTS LISTS

SECTION 6

Fig. 6e Indexing unit

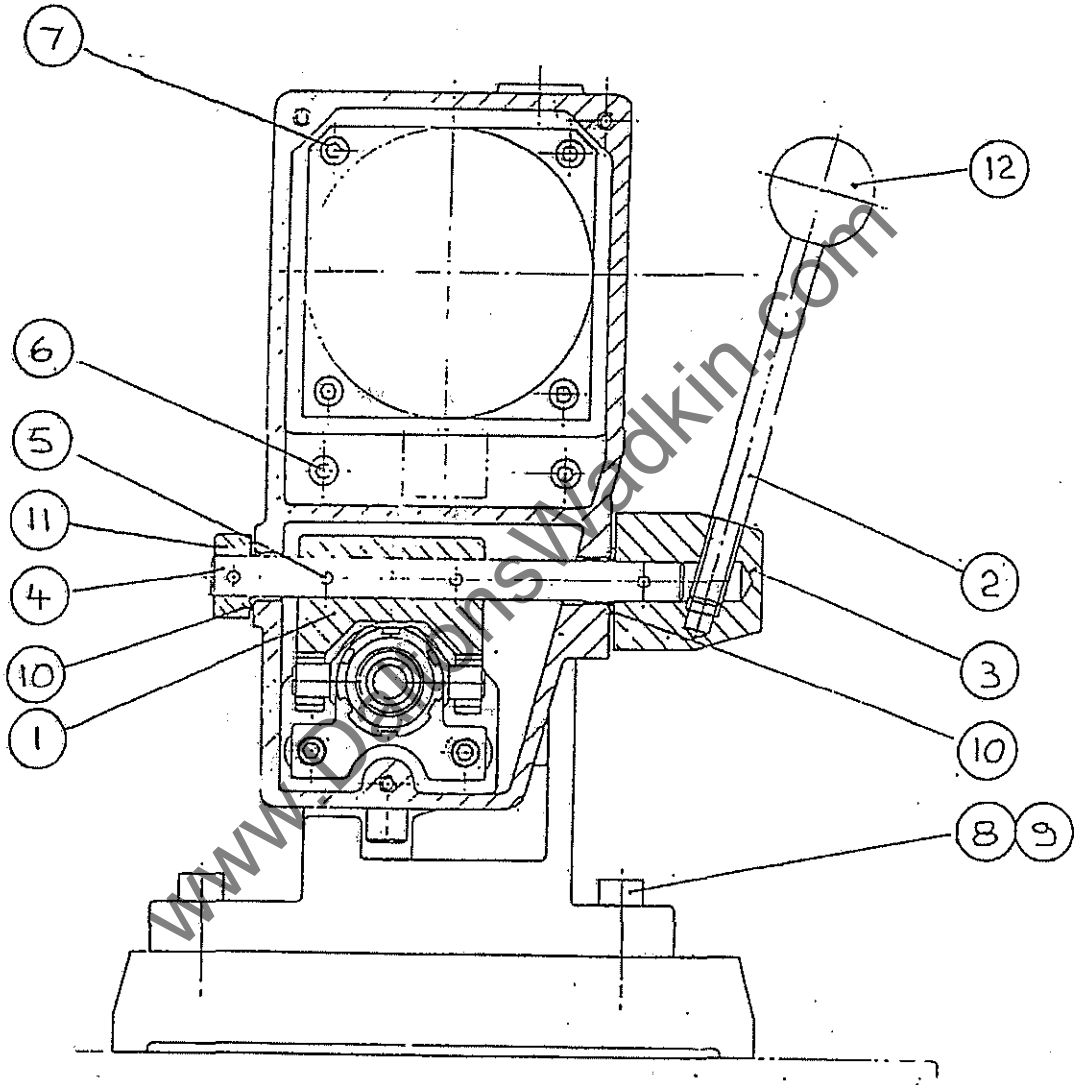



PARTS LISTS

SECTION 6

INDEXING UNIT *(Fig. 6e)*

<u>ITEM</u>	<u>QTY</u>	<u>PART No.</u>	<u>DESCRIPTION</u>
1	1	NHP 315	Retractor fork
2	1	NHP 332	Retract lever
3	1	NHP 333	Lever boss
4	1	NHP 334	Retract pivot
5	4	T0520503	Taper pin No.0
6	2	T0525145	Hex skt capscrew M5 x 20 mm
7	4	T0525147	Hex skt capscrew M5 x 30 mm
8	4	T0525188	Hex skt capscrew M8 x 25 mm
9	2	T0529144	Plain dowel 8 mm x 25 mm
10	2	T0505130	Glycodur Fl bush 12 x 14 x 9
11	1	K0528207	Collar 12 mm dia.
12	1	K0530324	Ball knob 10 mm re 10-125



PARTS LISTS

SECTION 6

Fig. 6f Head

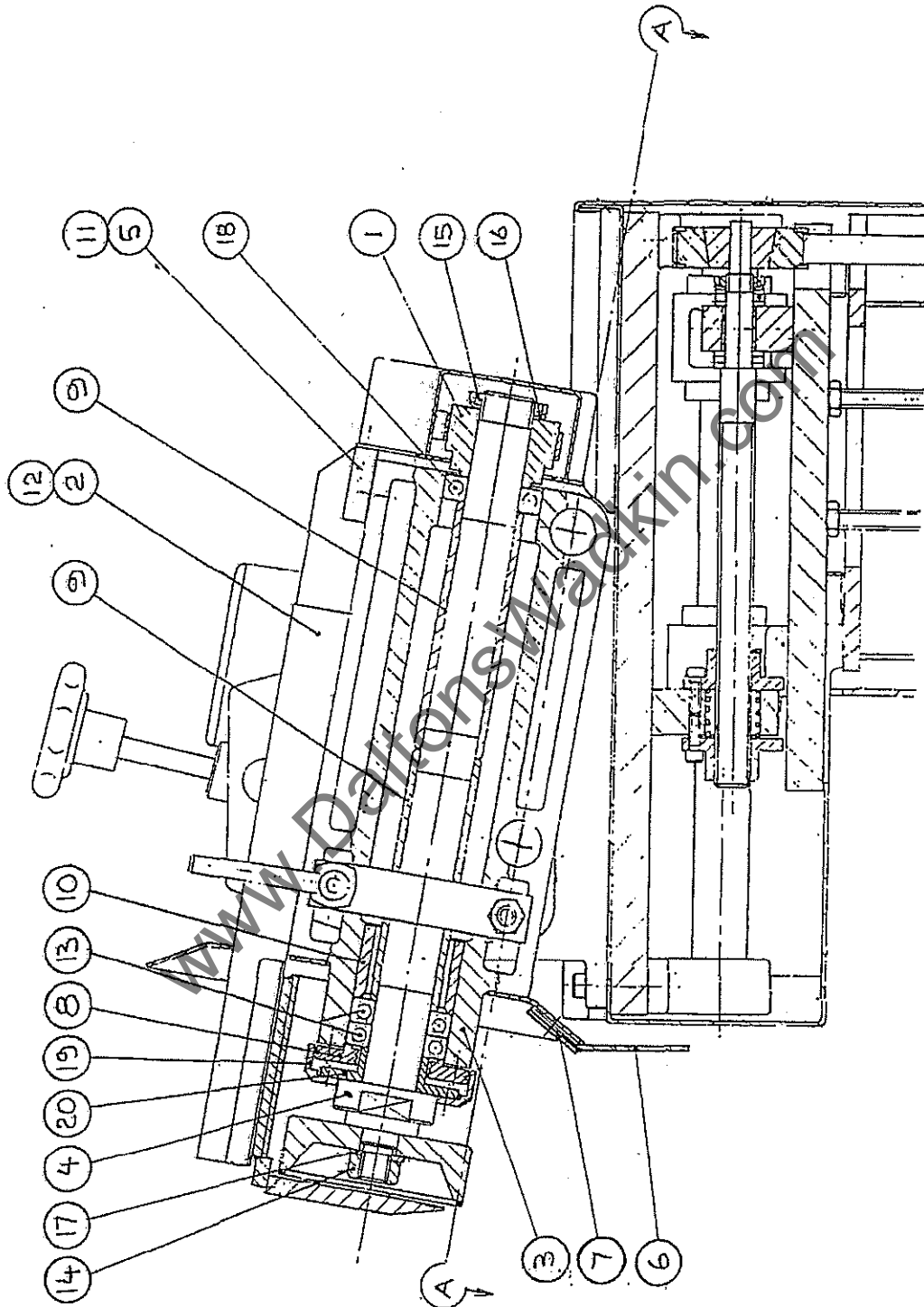



PARTS LISTS

SECTION 6

HEAD (Fig. 6f)

<u>ITEM</u>	<u>QTY</u>	<u>PART No.</u>	<u>DESCRIPTION</u>
1	1	NHP 124	Spindle pulley
2	1	NHP 137	Mounting bar for wheelguard
3	1	NHP 402	Spindle housing
4	1	NHP 470	Spindle
5	1	NHP 406	Strap
6	1	NHP 461	Flap for splashplate
7	1	NHP 462	Backing strip for s/plate
8	1	NXU 466	End_cap (inner)
9	2	NXU 326	Bearing spacer
10	1	NXU 327	Bearing shoulder
11	2	T0525165	Hex skt capscrew M6 x 16 mm
12	4	T0525171	Hex skt capscrew M6 x 45 mm
13	1	T3005305	Pair of angular cont:bearings
14	1	T3053104	Full nut M16 x 2 pitch LH
15	1	K0527207	Notch nut M30 x 1.5
16	1	K0527256	Tab lock washer 30 mm
17	1	K0528106	Washer 16 mm
18	1	K0601126	6006-2RS RHP & SKF bearing
19	1	NHP 467	Outer cap
20	1	NHP 468	Cap mounting ring



PARTS LISTS

SECTION 6

Fig. 6g Head

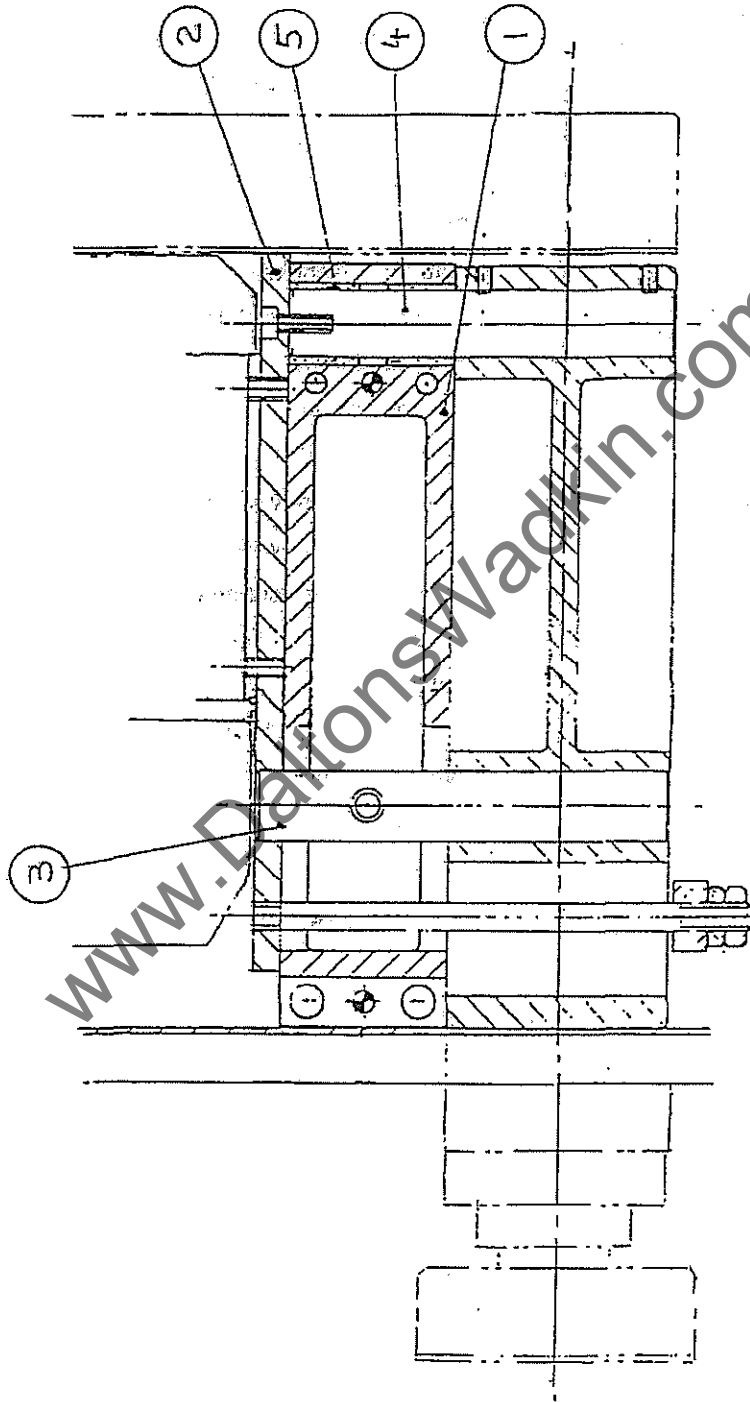

SECTION 'AA'



PARTS LISTS

SECTION 6

HEAD (Fig. 6g)

<u>ITEM</u>	<u>QTY</u>	<u>PART No.</u>	<u>DESCRIPTION</u>
1	1	NHP 401	Head mounting
2	1	NHP 404	Motor plate
3	1	NHP 408	R & F nut
4	1	NHP 409	Pivot shaft
5	2	T3005124	Bush 25 ID x 30 OD x 25 lg

www.DaltonsWadkin.com



PARTS LISTS

SECTION 6

Fig. 6h Head

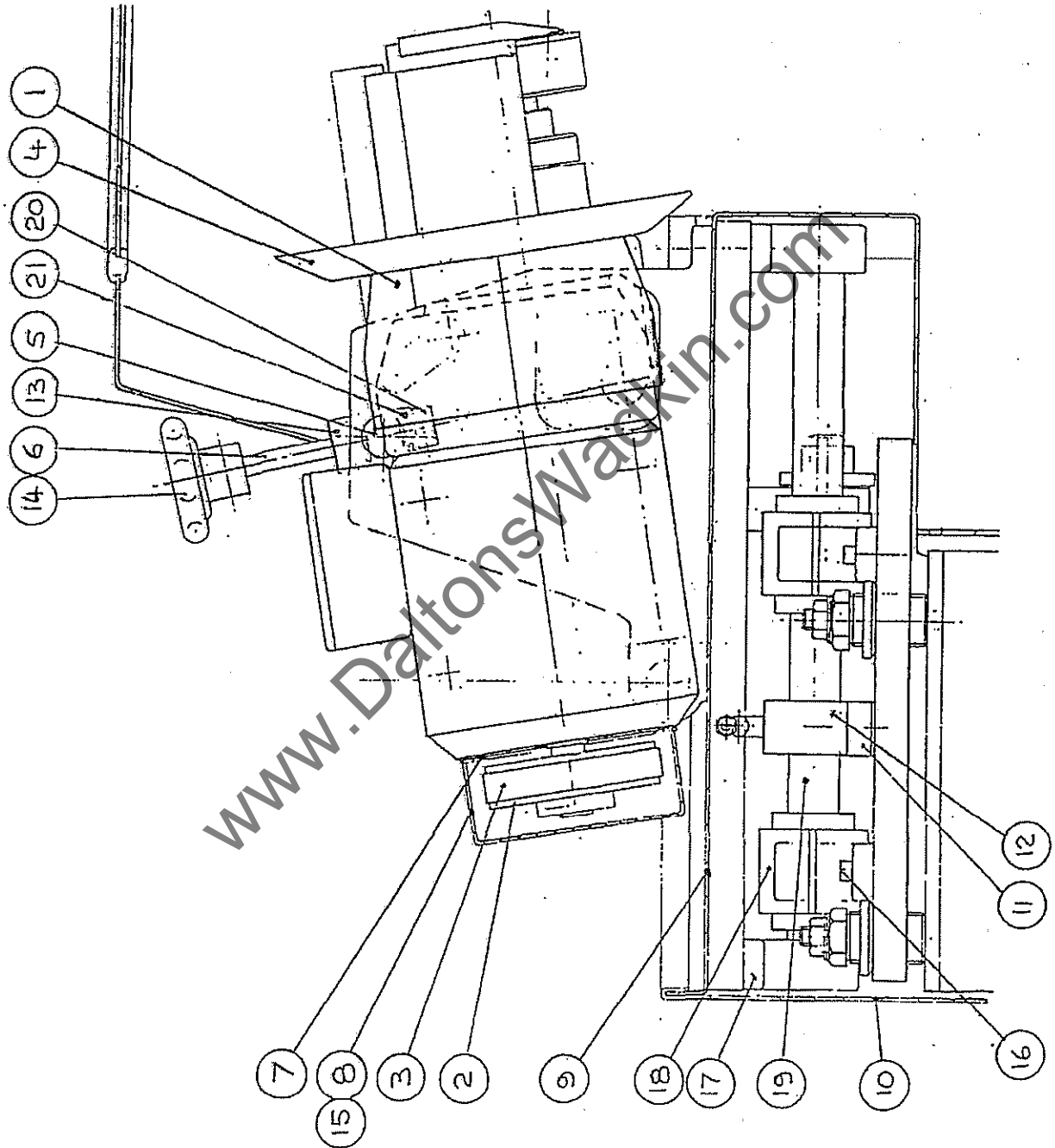



PARTS LISTS

SECTION 6

HEAD (Fig.6h)

<u>ITEM</u>	<u>QTY</u>	<u>PART No.</u>	<u>DESCRIPTION</u>
1	1	NHP 26	Motor cowl
2	1	NHP 110	Motor pulley (50 Hz)
3	1	NHP 134	Flat drive belt (50Hz)
4	1	NHP 405	Splash plate
5	1	NHP 410	Screw mounting
6	1	NHP 411	R & F screw
7	1	NHP 418	Back plate for belt guard
8	1	NHP 419	Belt guard
9	1	NHP 424	Cover tray
10	1	NHP 425	Rear cover for head
11	1	NHP 440	Limit switch bracket
12	1	NXUS0033	Telem L/switch with brg.
13	1	NXU 316	Collar with brg. guard
14	1	NXU 424	Handwheel plastic 13 mm square
15	2	T0525163	Hex skt capscrew M6 x 10 mm
16	8	T0525166	Hex skt capscrew M6 x 20 mm
17	4	T3005304	Shaft support block GW30
18	4	T3005322	INA brg. ref KGBS 3068 PP
19	2	T3005357	Shaft 30 dia. 435 lg
20	1	K0528207	Collar 12 mm dia.
21	2	K0604133	51101 RHP & SKF thrust bearing



PARTS LISTS

SECTION 6

Fig. 6i Head

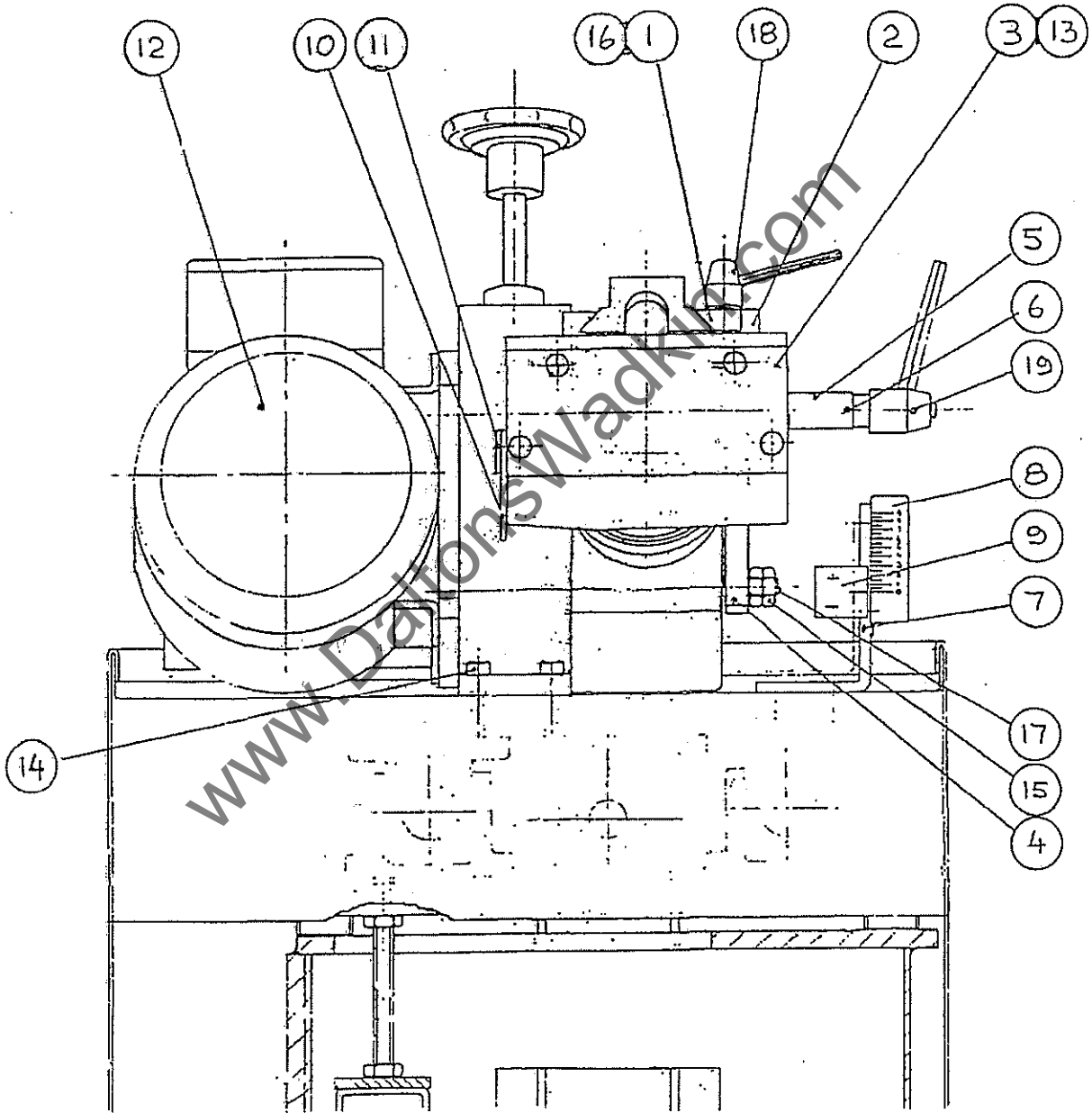



PARTS LISTS

SECTION 6

HEAD (Fig. 6i)

<u>ITEM</u>	<u>QTY</u>	<u>PART No.</u>	<u>DESCRIPTION</u>
1	1	NHP 111	Locking strip
2	1	NHP 139	Straight knife wheelguard
3	1	NHP 140	No 4 knife guide
4	1	NHP 407	Locking bar
5	1	NHP 412	Lock spacer
6	1	NHP 413	Locking stud
7	1	NHP 446	Scale bracket
8	1	NHP 447	Scale - head rise and fall
9	1	NHP 448	Scale indicator
10	1	NHP 459	Flap for wheel guard
11	1	NHP 460	Backing strip for guard
12	1	NX S0202	Motor 380 / 415 v 50 Hz
13	4	T0525164	Hex skt capscrew M6 x 12 mm
14	2	T0525188	Hex skt capscrew M8 x 25 mm
15	2	T0527103	M10 nut
16	2	T0573805	Coil spring 9 mm x 25 mm
17	2	K0526285	Screwed stud 10 mm x 185 mm
18	1	K0530241	Ratchet l/handle M8 x 12.5
19	1	K0530243	Locking handle M10



PARTS LISTS

SECTION 6

Fig. 6j Infeed mechanism

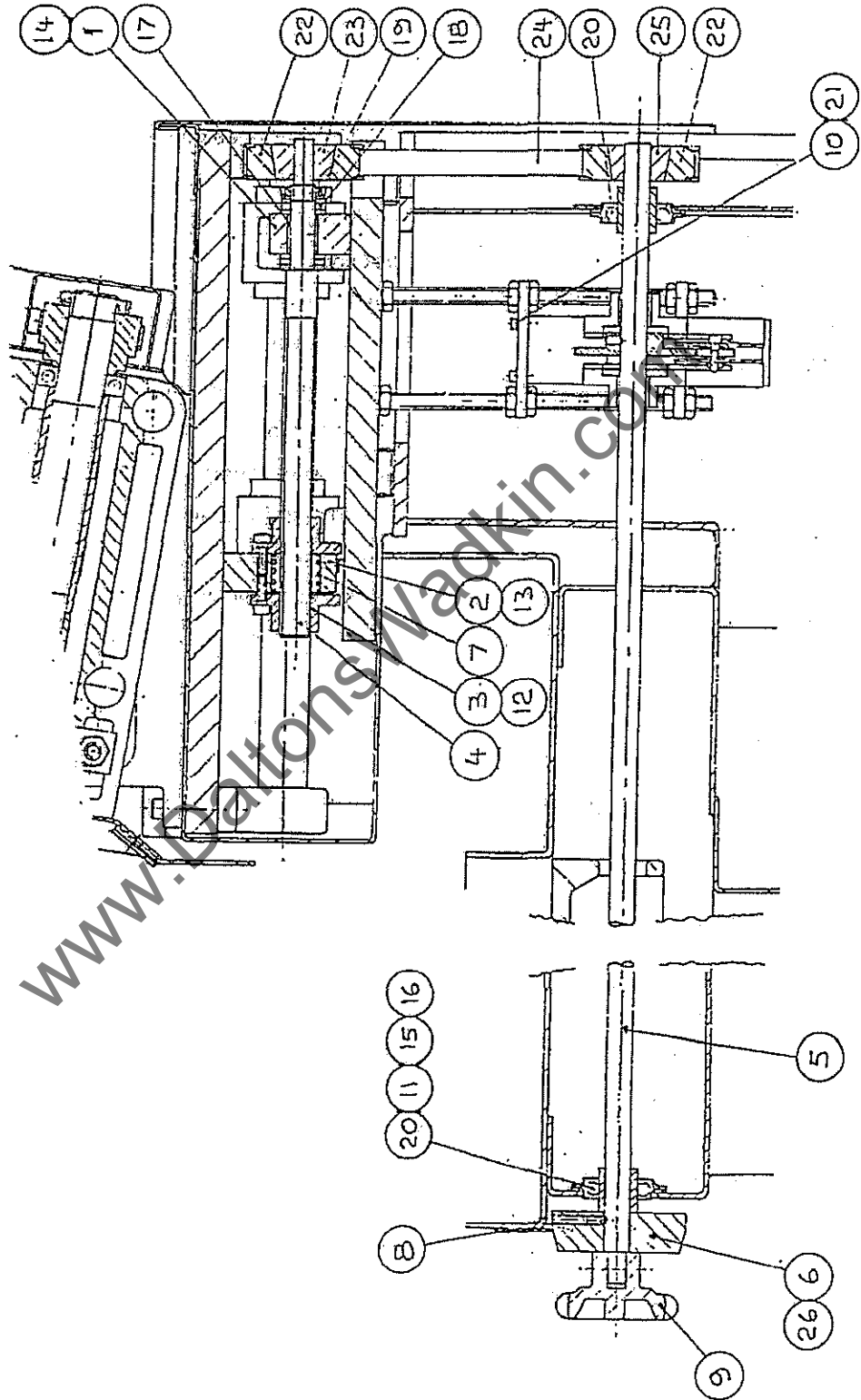



PARTS LISTS

SECTION 6

INFEED MECHANISM (Fig. 6f)

<u>ITEM</u>	<u>QTY</u>	<u>PART No.</u>	<u>DESCRIPTION</u>
1	1	NHP 415	Screw mounting
2	1	NHP 416	Nut mounting
3	2	NHP 417	Adjusting nut
4	1	NHP 420	Adjusting screw
5	1	NHP 421	Adjustment shaft
6	1	NHP 426	Graduated dial
7	1	NHP 435	Spring
8	1	NHP 453	Pointer plate for head
9	1	NXU 424	Handwheel plastic 13 mm square
10	2	T0525121	Hex skt capscrew M4 x 10 mm
11	4	T0525164	Hex skt capscrew M6 x 12 mm
12	6	T0525166	Hex skt capscrew M6 x 20 mm
13	2	T0525190	Hex skt capscrew M8 x 35 mm
14	2	T0525196	Hex skt capscrew M8 x 65 mm
15	4	T0527101	Nut M6
16	4	T0528102	Washer 6 mm
17	1	T3005107	Bush 15 ID x 19 OD x 25 lg
18	2	T3005321	SKF thrust bearing ref 51102
19	1	T3053109	Fuji locknut M15 x 1.0
20	2	T3005358	Flange bearing units SLFL.16
21	2	T3073158	Spring washer M4
22	2	T3077104	Timing pulley - 043F0044
23	1	T3077110	T/lock bush 1108
24	1	T3077355	Timing belt 128 tooth
25	1	T3077360	Taper lock bush 1108 - 16 mm
26	1	K0526611	Hex skt grubscrew M6 x 12 mm



PARTS LISTS

SECTION 6

Fig. 6k Infeed mechanism

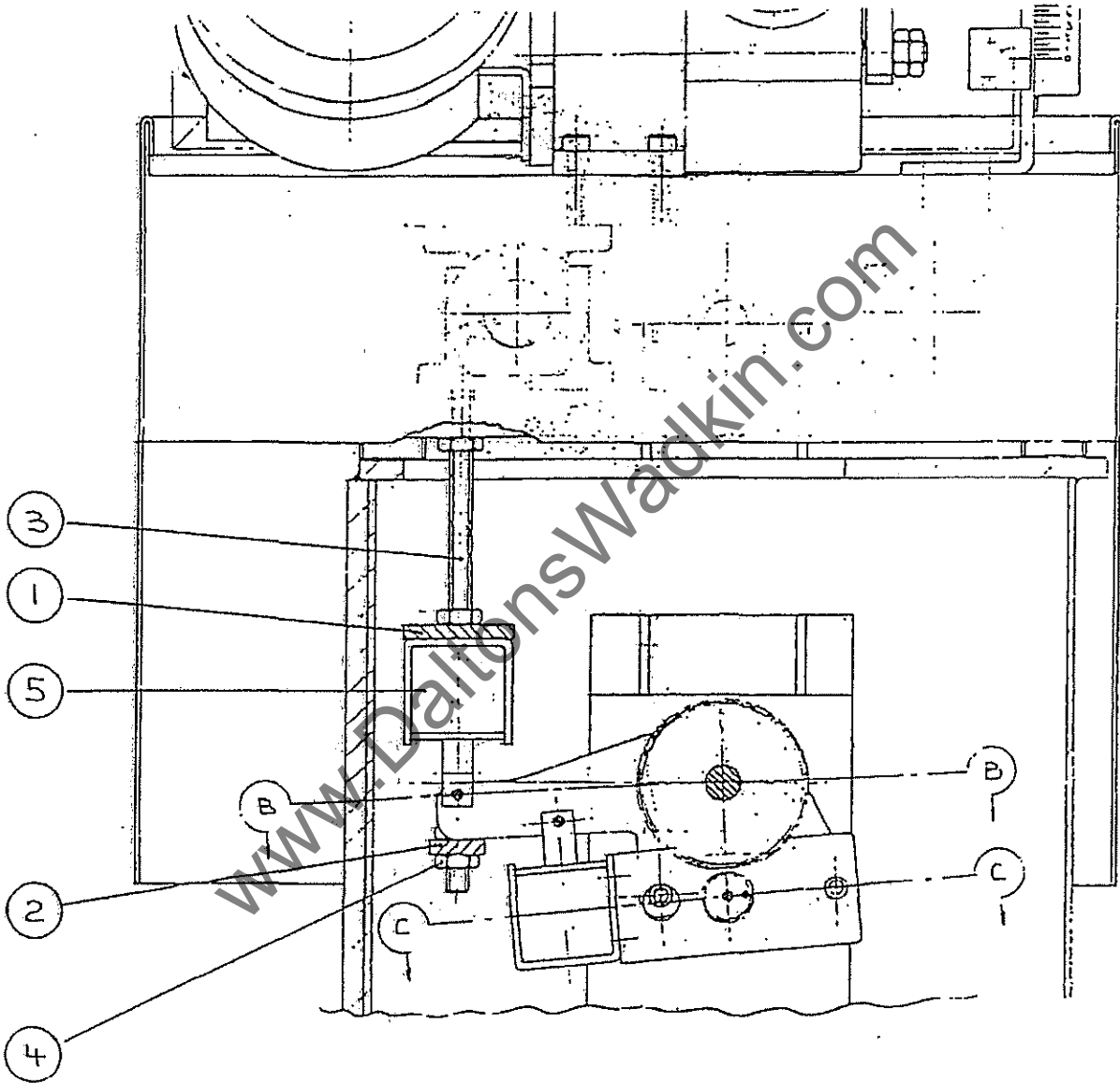



PARTS LISTS

SECTION 6

INFEED MECHANISM (Fig. 6k)

<u>ITEM</u>	<u>QTY</u>	<u>PART No.</u>	<u>DESCRIPTION</u>
1	1	NHP 430	Mount plate for solenoid
2	1	NHP 431	Stop plate
3	2	NHP 432	Stud
4	10	T0527103	Hex full nut M10
5	1	T3017165	Solenoid RS346-340

www.DaltonsWadkin.com



PARTS LISTS

SECTION 6

Fig. 61 Infeed mechanism

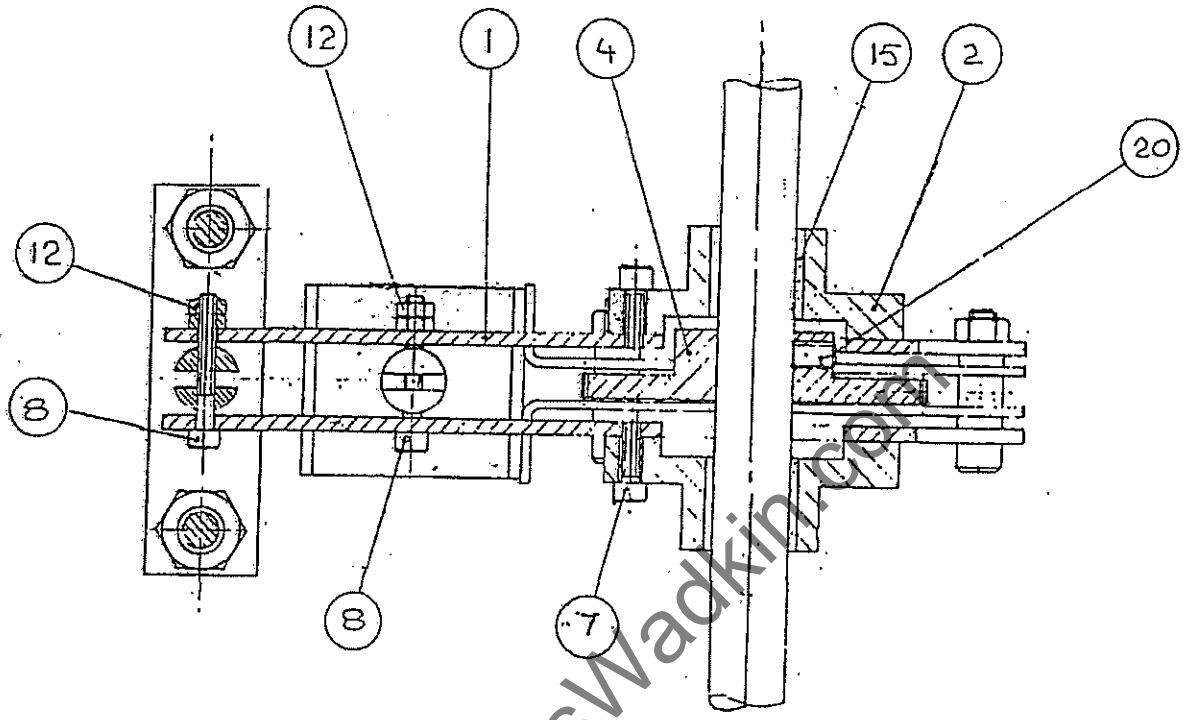

SECTION 'BB'

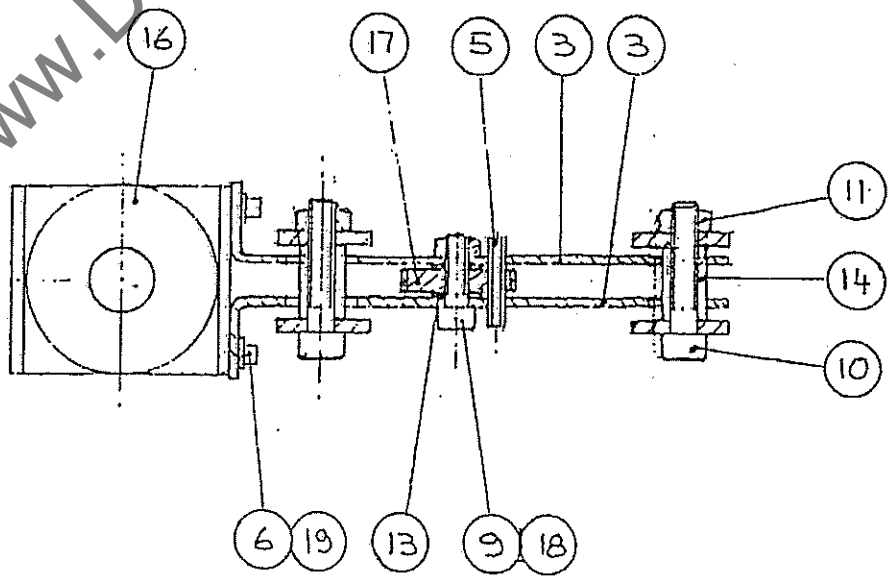

SECTION 'CC'



PARTS LISTS

SECTION 6

INFEED MECHANISM (Fig. 6f)

<u>ITEM</u>	<u>QTY</u>	<u>PART No.</u>	<u>DESCRIPTION</u>
1	2	NHP 427	Side plate for solenoid
2	2	NHP 428	Pivot boss
3	2	NHP 429	Side plate for lock gear
4	1	NHP 433	150T gear
5	1	T0520482	Tension pin 4 mm x 20 mm
6	2	T0525121	Hex skt capscrew M4 x 10 mm
7	6	T0525122	Hex skt capscrew M4 x 12 mm
8	2	T0525126	Hex skt capscrew M4 x 30 mm
9	1	T0525144	Hex skt capscrew M5 x 16 mm
10	2	T0525168	Hex skt capscrew M6 x 30 mm
11	2	T0527101	Hex full nut M6
12	4	T0527115	M4 full nut
13	2	T0528101	Washer 5 mm
14	2	T3005103	Bush 6 ID x 10 OD x 16 lg
15	2	T3005123	Bush 16 ID x 20 OD x 20 lg
16	1	T3017165	Solenoid RS346-340
17	1	T3025209	Spur gear 48T 0.5 mods
18	1	T3073138	Full nut M5
19	2	T3073158	M4 spring washer
20	1	K0526611	Hex skt screw cp 6 mm x 12 mm



PARTS LISTS

SECTION 6

Fig. 6m Table Assembly (NZ 350)

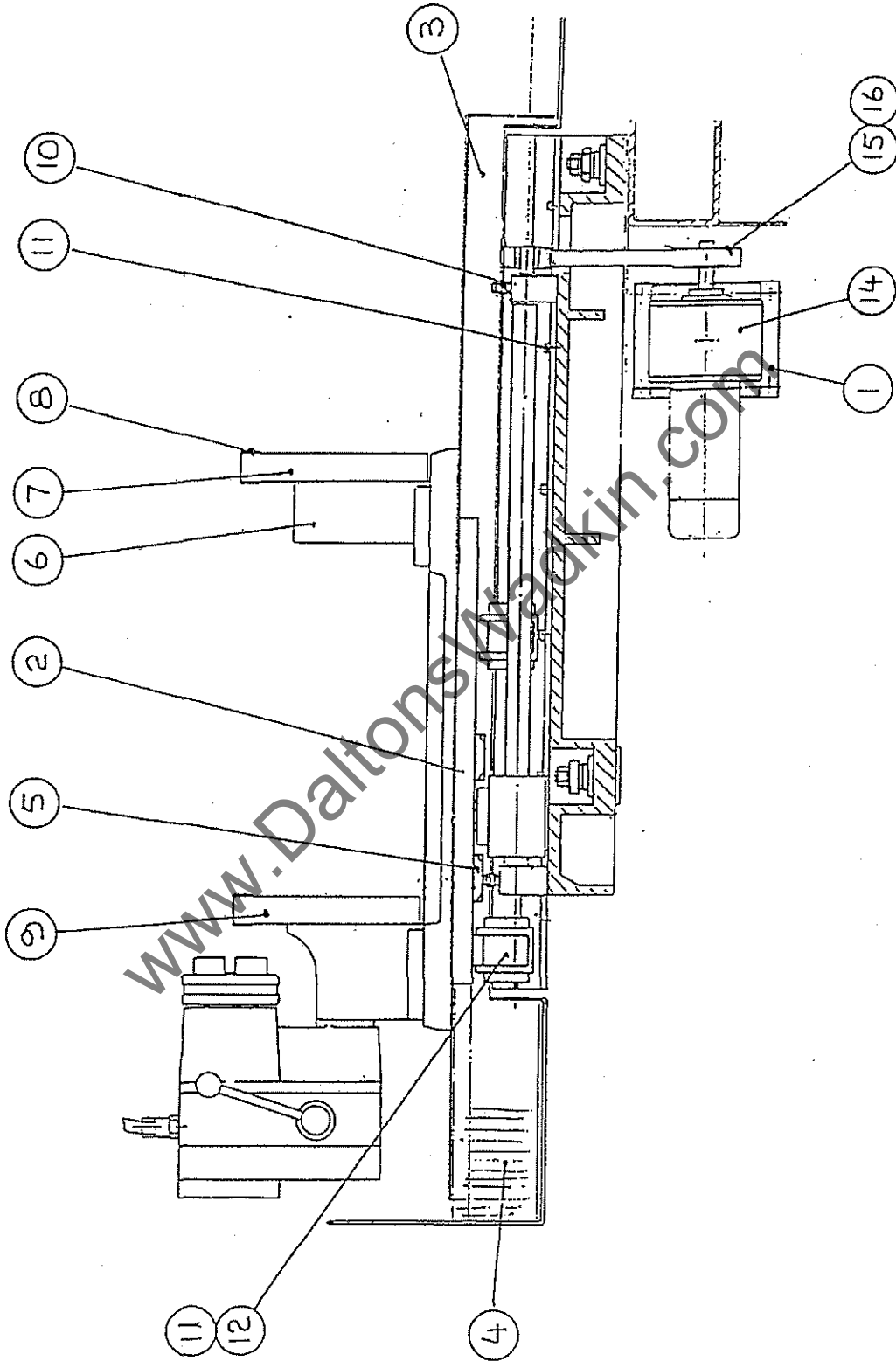



PARTS LISTS

SECTION 6

TABLE ASSEMBLY (NZ 350) (Fig. 6m)

<u>ITEM</u>	<u>QTY</u>	<u>PART No.</u>	<u>DESCRIPTION</u>
1	1	NHP 205	Mount plate for STM motor
2	1	NHP 246	Carriage plate
3	1	NHP 209	Carriage cover
4	1	NHP 210	Carriage bellows
5	2	NHP 218	Cam plate for limits
6	1	NHP 303	Arbor support
7	1	NHP 329	Arbor post RH
8	1	NHP 346	Arbor shell
9	1	NHP 347	Arbor post LH
10	2	NXUS0033	Limit switch
11	30	k0525144	Hex skl capscREW M5 x 16 mm
12	2	k0607179	Linear bearing assy (compriss 1 rail + 2 brgs)
13			
14	3	T3051110	MCP 63 6:1 gearbox
15	1	T3077104	Timing pulley - 043F0044
16	1	T3077539	Taper lock bush

NOTE : SEE Fig 6a FOR NZ 300 TABLE ASSEMBLY



APPENDIX

A1

APPROVED LUBRICANTS

Wadkin	B.P.	Caltex	Castrol	Esso	Gulf	Mobil	Shell
L1	Energol HLP 32	Rando	Hyspin AWS 32	Nuto H32 43 AW	Harmony Oil HDA	DTE oil Light 24	Tellus 37
L2	Energol HP 150	URSA P40	Alpha ZN 150	Spartan EP 150 Heavy	Service 13	Vactra Extra	Vitrea 150 or CS 150
L4	Energol HP 68	URSA P20	Magna 68	Nurray 68 Heavy Medium	Service 51	Vactral Oil	Vitrea 68 or CS 68
L6	Energol LS 3	Regal Startak Premium 3	Spheerol AP3	Beacon 3	Gulfcrown Grease No. 3	Mobilplex Grease No. 48	Alvania Grease No. 3

- L1 Oil Hydraulic oil with anti-corrosion, anti-oxidation, anti-wear, anti-foam performance.
- L2 Oil Gear oil (viscosity 150 centi-stokes at 40 degrees C).
- L3 Oil Plain mineral oil (viscosity 68 centi-stokes at 40 degrees C.)
- L6 Grease Grease NLG1 No.3 consistency lithium bearing grease.



APPENDIX

A2

NXT 138 GRINDING COOLANT

IMPORTANT : The following information is reproduced for reference only. When handling coolant from ANY supplier ALWAYS use the data sheets provided with the product.

APPLICATION

The recommended dilution for use on this machine is 2% by volume (i.e. 50 : 1 water to coolant ratio).

Measure (do not guess) the required volume of water into a clean coolant tank or other suitable container.

Calculate the volume of coolant concentrate required. For example 30 litres of water would require 0.6 litres of coolant concentrate.

Always mix the emulsion by introducing the concentrate gradually to water. Continuously paddle the emulsion during mixing, circulating the fluid from bottom to top. Care should be taken to ensure that the emulsion is properly formed. Failure to do so may result in an emulsion of water in oil rather than oil in water. If an emulsion of water in oil is formed then it will have none of the properties normally expected of the coolant, and will lead to rapid rusting.

POINTS TO REMEMBER :-

- Always add the coolant to water - NEVER vice versa.
- DON'T prepare coolant mixtures by guesswork - measure all quantities.
- NEVER pour the coolant concentrate into the water too quickly. It must be mixed in at a steady rate to achieve a stable emulsion.
- DON'T use dirty, saline, or hard water. Rain water is only acceptable if clean and free from debris.
- DON'T use dirty, rusted, galvanised or "old-oil" contaminated buckets etc.
- NEVER try to mix the coolant using the coolant pump.



APPENDIX

A2

TYPICAL PHYSICAL CHARACTERISTICS		
Concentrate :		
Appearance	-	Amber
Relative density at 20° C	-	1.002 gm/cm ³
Emulsion :		
Appearance	-	Translucent / white liquid.
pH at 3% concentration	-	9.1 - 9.4
Refractometer Factor	-	1.4

TOPPING UP

If it is found necessary to 'top up' the coolant tank at a later stage, allowance should be made for water evaporation. This is necessary to prevent a gradual increase in fluid concentration. An approximate dilution of 1% by volume when 'topping up' will normally achieve this.

NEVER ADD NEAT COOLANT TO STRENGTHEN, OR JUST WATER TO WEAKEN, EMULSIONS THAT ARE ALREADY IN USE IN THE MACHINE.

Incorrect coolant strength MUST ALWAYS be compensated for by adding either a stronger or weaker EMULSION to the existing mix. Failure to observe this criteria is the cause of most aspects of poor coolant performance.

Remember to multiply direct refractometer readings by the refractive index of the product to gain the true coolant concentration figure.

NOTE : If the concentration should become too high, above a maximum of 10%, not only will the emulsion become unstable, but there is also the possibility of skin complaints among operators.

NOTE : Wadkin Plc reserve the right to change the type of cutting fluid supplied to our customers at any time. However, any changes of supply will be accompanied by the necessary safety data sheets.



APPENDIX

A2



Castrol (U.K.) Limited

The Leading Lubricant Specialist

SAFETY DATA SHEET



1: IDENTIFICATION OF THE SUBSTANCE / PREPARATION AND OF THE COMPANY / UNDERTAKING

Product Name: **Hysol G** Code: **7040-UK**
 Application: Metalworking fluid - Soluble
 Company: Castrol (U.K.) Limited
 Address: Burmah Castrol House, Pipers Way, Swindon, Wiltshire, SN3 1RE
 Telephone (24 hours): 0793 512712 Fax: 0793 432872

2: COMPOSITION/INFORMATION ON INGREDIENTS

Composition: Highly refined mineral oil, emulsifiers and additives

Hazardous Ingredient(s)	Symbol	Risk Phrases	Other Information	%
-------------------------	--------	--------------	-------------------	---

This product contains ingredients classified as hazardous. However, they are NOT present in sufficient quantities to warrant classifying the product as hazardous

All constituents of this product are listed in EINECS (European Inventory of Existing Commercial Chemical Substances) or ELINCS (European List of New Chemical Substances) or are exempt.

Refer to Section 8 for Occupational Exposure Limits.

3: HAZARDS IDENTIFICATION

This product is NOT classified as hazardous

4: FIRST AID MEASURES

Eyes: Irrigate immediately with copious quantities of water for several minutes. Obtain medical attention if irritation persists.

Skin: Wash thoroughly with soap and water or suitable skin cleanser as soon as possible.

Inhalation: Remove from exposure.

Ingestion: Obtain medical attention urgently. Do NOT induce vomiting. Wash out mouth with water.

5: FIRE FIGHTING MEASURES

Suitable Extinguishing Media: Carbon dioxide, powder, foam or water fog - Do not use water jets

Special Exposure Hazards: Nitrogen compounds

Special Protective Equipment: Self-contained breathing apparatus

Issue No: 01	Date: 01/04/1994	Code: 7040-UK	Page: 1 of 4
--------------	------------------	---------------	--------------



APPENDIX

A2

6: ACCIDENTAL RELEASE MEASURES

Personal Precautions: Spilt product presents a significant slip hazard
 Environmental Precautions: Prevent entry into drains, sewers and water courses
 Decontamination Procedures: Soak up with inert absorbent or contain and remove by best available means

7: HANDLING AND STORAGE

Handling: To avoid the possibility of skin disorders, repeated or prolonged contact with products of this type must be avoided. It is essential to maintain a high standard of personal hygiene
 Avoid breathing spray mist

Storage: Protect from frost. Store out of direct sunlight. Store between (°C): 5-50

8: EXPOSURE CONTROLS/PERSONAL PROTECTION

Occupational Exposure Limits:-

Substance	8 Hr.TWA	STEL	Source/Other Information
Mineral oil (see Oil mist, mineral)	5mg/m ³	10mg/m ³	EH40

Engineering Control Measures: Local exhaust ventilation is recommended. Mechanical methods to minimise exposure must take precedence over personal protective measures.

Personal Protective Equipment: Safety glasses. Plastic apron. Wear impervious gloves (eg of PVC), in case of repeated or prolonged contact.
 Change contaminated clothing and clean before re-use

9: PHYSICAL AND CHEMICAL PROPERTIES

Physical State:	Liquid
Colour:	Amber
Odour:	Mild
pH(concentrate):	Not applicable
pH(working dilution):	9 (5%)
Boiling Point/Range (°C):	Above 100
Flash Point (closed, °C):	Above 100
Autoignition (°C):	Not determined
Relative Density (at 20°C):	Below 1.0
Water Solubility:	Emulsifiable
Fat Solubility:	Not determined

10: STABILITY AND REACTIVITY

Stability: Stable, will not polymerise

Issue No: 01

Date: 01/04/1994

Code: 7040-UK

Page: 2 of 4



APPENDIX

A2

Conditions to Avoid: Temperatures (°C) above 60
 Materials to Avoid: Strong oxidising agents. Strong acids.
 Hazardous Decomposition Products: Nitrogen compounds

11: TOXICOLOGICAL INFORMATION

The following toxicological assessment is based on a knowledge of the toxicity of the product's components.
 Expected oral LD₅₀, rat > 2g/kg. Expected dermal LD₅₀, rabbit > 2g/kg.
 Not classified as an eye or skin irritant

Health Effects

On Eyes: May cause transient irritation
 On Skin: May defat the skin
 By Inhalation: Mist and vapours may cause irritation to nose and respiratory tract
 By Ingestion: May cause nausea, vomiting and diarrhoea
 Chronic: Repeated and prolonged skin contact may lead to skin disorders
 Other: None known

12: ECOLOGICAL INFORMATION

Environmental Assessment: May cause significant ecological damage in aquatic systems and must be used and disposed of in accordance with the recommendations made in this safety data sheet.
 Mobility: Mobile liquid. Emulsifiable in water.
 Persistence and Degradability: Not readily biodegradable.
 Bioaccumulative Potential: Not determined
 Ecotoxicity: Not determined

13: DISPOSAL CONSIDERATIONS

Disposal must be in accordance with local and national legislation.
 Unused Product: Dispose of through an authorised waste contractor to a licensed site
 Used/Contaminated Product: Diluted product may be separated by chemical means before removal by an authorised waste contractor
 For further information see Section 16
 Packaging: Must be disposed of through an authorised waste contractor
 May be steam cleaned and recycled

14: TRANSPORT INFORMATION

This product is NOT classified as dangerous for transport

15: REGULATORY INFORMATION

Hazard Label Data:-

This product is NOT classified as dangerous for supply in the UK

EC Directives: Framework Waste Directive, 91/156/EEC
 Waste Oil Directive, 87/101/EEC

Issue No: 01

Date: 01/04/1994

Code: 7040-UK

Page: 3 of 4



APPENDIX

A2

Statutory Instruments:	Health & Safety at Work, etc. Act 1974 Consumer Protection Act 1987 Environmental Protection Act 1990
Codes of Practice:	Waste Management. The Duty of Care
Guidance Notes:	Occupational skin diseases: health and safety precautions (EH 26) Occupational exposure limits (EH 40) Carcinogenicity of mineral oils (EH 58) Metalworking fluids - health precautions (EH 62) Skin cancer caused by oil [MS(B)5] Save your skin! - Occupational Contact Dermatitis [MS(B)6] Dermatitis - cautionary notice [SHW 367] Effects of mineral oil on the skin [SHW 397]

The above publications are available from HMSO or HSE

16: OTHER INFORMATION

Castrol publication: Talking about Cutting Fluids
Castrol Advice Sheet: The Disposal of Used Metalworking Fluids
Castrol publication: Talking About Health and Safety - Lubricants and Allied Products

The data and advice given apply when the product is sold for the stated application or applications. The product is not sold as suitable for any other application. Use of the product for applications other than as stated in this sheet may give rise to risks not mentioned in this sheet. You should not use the product other than for the stated application or applications without seeking advice from us.

If you have purchased the product for supply to a third party for use at work, it is your duty to take all necessary steps to secure that any person handling or using the product is provided with the information in this sheet.

If you are an employer, it is your duty to tell your employees and others who may be affected of any hazards described in this sheet and of any precautions which should be taken.

Further copies of this Safety Data Sheet may be obtained from Castrol (U.K.) Limited.

Issue No: 01

Date: 01/04/1994

Code: 7040-UK

Page: 4 of 4



APPENDIX

A3

NXT 145 ANTI-BACTERIAL SOLUTION

IMPORTANT : The following information is reproduced for reference only. When handling anti-bacterial solutions from ANY supplier ALWAYS use the data sheets provided with the product.

The solution normally supplied by Wadkin is a nitrite-free, medium to heavy duty machine tool cleaner / steriliser based on a powerful detergent. It has been specially formulated to deal with a wide variety of machine tool contaminants and is easy to use, being added directly to the coolant system whilst still in operation.

- Cleans machine tool systems of a wide range of contaminants including fatty build up in pipelines and floor ducts.
- Kills bacteria and emulsifies floating tramp oil.
- Particularly useful in areas of hard water where greater amounts of insoluble material are likely to occur.
- Minimises maintenance downtime.
- Can be used whilst machines are operating normally.
- Helps keep machine tools in a clean and efficient condition.

APPLICATION

- 1) An addition of 0.5% - 2% of System Cleaner is recommended. The amount added depends on the general condition of the coolant system (1% is usually adequate).
- 2) Introduce System Cleaner where there is good coolant movement, e.g. in the main coolant tray near to the drain hole position. This ensures complete mixing with the cutting fluid.
- 3) Add System Cleaner on the day before the coolant is programmed to be discarded. The machine should then be operated normally for a minimum of eight hours.
- 4) Following this period of circulation, empty the entire coolant system and machine, and dispose of the coolant in accordance with local authority regulations.

TECHNICAL DATA

Alkalinity	Medium (contains a small amount of free caustic)
Density @ 20 ^o C	1.080
pH (1% solution)	11.25
Surface tension (1% solution at 20 ^o C)	34mN/m
Appearance	Blue liquid, moderately viscous

NOTE : Wadkin Plc reserve the right to change the type of anti-bacterial solution supplied to our customers at any time. However, any changes of supply will be accompanied by the necessary safety data sheets.



APPENDIX

A3



Castrol (U.K.) Limited

The Leading Lubricant Specialist

SAFETY DATA SHEET



1: IDENTIFICATION OF THE SUBSTANCE / PREPARATION AND OF THE COMPANY / UNDERTAKING

Product Name: **System Cleaner** Code: **7949-UK**
 Application: Machine tool coolant system cleaning
 Company: Castrol (U.K.) Limited
 Address: Burmah Castrol House, Pipers Way, Swindon, Wiltshire, SN3 1RE
 Telephone (24 hours): 0793 512712 Fax: 0793 432872

2: COMPOSITION/INFORMATION ON INGREDIENTS

Composition: Aqueous solution of alkalis, surfactants and additives

Hazardous Ingredient(s)	Symbol	Risk Phrases	Other Information	%
Sodium hydroxide	C	R35	CAS No 1310-72-2	0.5 - 2
1,3,5-Tris- (2-hydroxyethyl)-1,3,5-hexahydrotriazine	Xi	R22, 36/38	CAS No 4719-04-4	< 20

All constituents of this product are listed in EINECS (European Inventory of Existing Commercial Chemical Substances) or ELINCS (European List of New Chemical Substances) or are exempt.

Refer to Section 8 for Occupational Exposure Limits.

3: HAZARDS IDENTIFICATION

Irritating to eyes and skin



IRRITANT

4: FIRST AID MEASURES

Eyes: Irrigate immediately with copious quantities of water for several minutes
Obtain medical attention urgently

Skin: Wash immediately with soap and water or suitable skin cleanser
Obtain medical attention if irritation persists

Inhalation: Remove from exposure

Ingestion: Obtain medical attention. Do NOT induce vomiting. Wash out mouth with water.

5: FIRE FIGHTING MEASURES

Suitable Extinguishing Media: Carbon dioxide, powder, foam or water

Issue No: 01

Date: 01/04/1994

Code: 7949-UK

Page: 1 of 4



APPENDIX

A3

Special Exposure Hazards: Nitrogen compounds
 Special Protective Equipment: Self-contained breathing apparatus

6: ACCIDENTAL RELEASE MEASURES

Personal Precautions: Spilt product presents a significant slip hazard
 Wear rubber boots in addition to the recommended protective clothing

Environmental Precautions: Prevent entry into drains, sewers and water courses

Decontamination Procedures: Soak up with inert absorbent or contain and remove by best available means. Clean contaminated area with water.

7: HANDLING AND STORAGE

Handling: Handle and open containers with care. Avoid skin and eye contact. Avoid breathing spray mist.
 Storage: Protect from frost. Store only in hazard labelled containers.

8: EXPOSURE CONTROLS/PERSONAL PROTECTION

Occupational Exposure Limits:-

Substance	8 Hr. TWA	STEL	Source/Other Information
Sodium hydroxide	-	2mg/m ³	EH40
Formaldehyde (formed in solution)	2ppm (MEL)	2ppm (MEL)	EH40

Engineering Control Measures: Local exhaust ventilation is recommended. Mechanical methods to minimise exposure must take precedence over personal protective measures.

Personal Protective Equipment: Goggles. Impervious gloves (eg PVC). Plastic apron.
 Change contaminated clothing immediately and clean before re-use.
 An eye wash station must be available.

9: PHYSICAL AND CHEMICAL PROPERTIES

Physical State:	Liquid
Colour:	Blue
Odour:	Sharp
pH(concentrate):	13.3
pH(working dilution):	11.3 (1%)
Boiling Point/Range (°C):	Above 100
Melting Point/Range (°C):	Below 0
Flash Point (closed, °C):	None, as supplied
Relative Density (at 20°C):	Above 1.0
Water Solubility:	Soluble
Fat Solubility:	Not determined

10: STABILITY AND REACTIVITY

Stability: Stable, will not polymerise
 Conditions to Avoid: Temperatures (°C) above 60

Issue No: 01	Date: 01/04/1994	Code: 7949-UK	Page: 2 of 4
--------------	------------------	---------------	--------------



APPENDIX

A3

Materials to Avoid: Strong acids
 Hazardous Decomposition Products: Irritant fumes. Formaldehyde. Nitrogen compounds.

11: TOXICOLOGICAL INFORMATION

The following toxicological assessment is based on a knowledge of the toxicity of the product's components
 Classified as an eye and skin irritant. Recommended working concentrations are not classified as eye or skin irritants.

Health Effects

On Eyes: Irritating and may injure eye tissue if not removed promptly
 On Skin: Irritation
 By Inhalation: Mist and vapours may cause irritation to nose and respiratory tract
 By Ingestion: May cause irritation of mouth, throat and digestive tract
 Chronic: None known
 Other: None known

12: ECOLOGICAL INFORMATION

Environmental Assessment: May cause significant ecological damage in aquatic systems and must be used and disposed of in accordance with the recommendations made in this safety data sheet
 Mobility: Mobile liquid. Soluble in water.
 Persistence and Degradability: Inherently biodegradable
 Bioaccumulative Potential: Not determined
 Ecotoxicity: Not determined

13: DISPOSAL CONSIDERATIONS

Disposal must be in accordance with local and national legislation.
 Unused Product: Dispose of through an authorised waste contractor to a licensed site
 Used/Contaminated Product: As for Unused Product
 Diluted product may be separated by chemical means or reverse osmosis
 Packaging: Contains hazardous residues, must be disposed of through an authorised waste contractor. May be steam cleaned and recycled.

14: TRANSPORT INFORMATION

This product is NOT classified as dangerous for transport

15: REGULATORY INFORMATION

Hazard Label Data:-

Named Ingredients: Sodium hydroxide 0.5-2.0%
 Symbol(s): Xi
 Risk Phrases: Irritating to eyes and skin

Issue No: 01

Date: 01/04/1994

Code: 7949-UK

Page: 3 of 4



APPENDIX

A3

Safety Phrases:	In case of contact with eyes, rinse immediately with plenty of water and seek medical advice After contact with skin, wash immediately with plenty of soap and water Wear suitable protective clothing, gloves and eye/face protection
EC Directives:	Dangerous Preparations Directive, 83/379/EEC Safety Data Sheets Directive, 91/155/EEC Framework Waste Directive, 91/156/EEC
Statutory Instruments:	Health & Safety at Work, etc. Act 1974 Chemicals (Hazard Information and Packaging) Regs. 1993 (SI 1746) Consumer Protection Act 1987 Control of Substances Hazardous to Health Regs. 1988 (SI 1657) Environmental Protection Act 1990
Codes of Practice:	Classification & labelling of substances dangerous for supply (COP 22) Waste Management. The Duty of Care
Guidance Notes:	Storage of packaged dangerous substances [CS 17 / HS(G)71] Occupational exposure limits (EH 40) Occupational skin diseases: health and safety precautions (EH 26) Classification, Packaging & Labelling of Dangerous Substances Regs. 1984 [HS(R)22] Save your skin! - Occupational Contact Dermatitis [MS(B)6] Dermatitis - cautionary notice [SHW 367]

The above publications are available from HMSO or HSE

16: OTHER INFORMATION

Information approved for the classification, packaging and labelling of dangerous substances for supply and conveyance by road (Third Edition)
Castrol publication: Talking About Health and Safety - Lubricants and Allied Products

The data and advice given apply when the product is sold for the stated application or applications. The product is not sold as suitable for any other application. Use of the product for applications other than as stated in this sheet may give rise to risks not mentioned in this sheet. You should not use the product other than for the stated application or applications without seeking advice from us.

If you have purchased the product for supply to a third party for use at work, it is your duty to take all necessary steps to secure that any person handling or using the product is provided with the information in this sheet.

If you are an employer, it is your duty to tell your employees and others who may be affected of any hazards described in this sheet and of any precautions which should be taken.

Further copies of this Safety Data Sheet may be obtained from Castrol (U.K.) Limited.

Issue No: 01	Date: 01/04/1994	Code: 7949-UK	Page: 4 of 4
--------------	------------------	---------------	--------------



APPENDIX

A4

TOOLS AND ACCESSORIES SUPPLIED WITH THE NZ

<u>Qty</u>	<u>Part No.</u>	<u>Description</u>
1	GW 301	Borazon wheel
1	K30 41140	Allen key 2.5 mm A/F
1	K30 41141	Allen key 3 mm A/F
1	K30 41142	Allen key 4 mm A/F
1	K30 41143	Allen key 5 mm A/F
1	K30 41144	Allen key 6 mm A/F
1	K30 41145	Allen key 8 mm A/F
1	K30 41146	Allen key 10 mm A/F
1	K30 45285	Grease gun
1	K30 73724	Locknut spanner 46 mm A/F
1	K30 73785	D/ended spanner 24 x 27 A/F
1	NHP 112	Setting gauge
1	NXT 138	Grinding coolant conc. 5 litres
1	T30 29105	Crank handle - 13 mm square
1	NXT 606	40 mm dia. arbor
1	NXT 301	40 mm bore locking collar
1	NXT 302	40 mm bore threaded collar
1	NXT 303	Clamping nut for collar
1	NXT 304	Tommy bar
1	T30 41110	5mm A/F handled Allen key

Note : 40 mm diameter arbor and locking collars are supplied unless specified otherwise.



APPENDIX

A5

ACCESSORIES FOR NZ MACHINES

GRINDING WHEELS

GW	301	Borazon wheel for H.S.S. knives.
GW	303	Diamond wheel for T.C.T. knives.

Note : Straight knife grinding wheels are 100 mm diameter, 20 mm bore, and are designed for face grinding at up to 6000 rpm.

HEAVY DUTY ARBORS

NXT	606	40 mm diameter
NXT	608	45 mm diameter
NXT	610	50 mm diameter
NXT	612	60 mm diameter
NXT	632	1 1/2" diameter
NXT	634	1 5/8" diameter
NXT	636	1 3/4" diameter
NXT	638	1 13/16" diameter
NXT	640	2 1/8" diameter
NXT	642	1 13/16" diameter with keyways
NXT	644	2 1/8" diameter with keyways

Note : Each arbor includes one set of locking collars. Heavy duty arbors have a 37 mm O.D. support bearing. The standard arbor supplied with the machine is NXT 606 unless specified otherwise.

SMALLER ARBOR SIZES

NXT	602	30 mm diameter
NXT	604	35 mm diameter
NXT	626	1 1/8" diameter
NXT	628	1 1/4" diameter
NXT	630	1 3/8" diameter

Note : Each arbor includes one set of locking collars. The smaller arbors have a 28 mm O.D. support bearing. If these arbors are used, the following shell is also required.

NXU	188	Arbor shell for smaller arbors. (28 mm dia bearing.)
-----	-----	--



APPENDIX

A5

KNIFE GUIDES

NHP	141	No. 6 Knife guide for 6 mm thick knives
NHP	142	No.8 Knife guide for 8 mm thick knives
NHP	143	No. 9 Knife guide for 3/8" thick knives
NHP	144	No. 11 Knife guide for 7/16" thick knives

Note : The No. 4 knife guide supplied with the machine is suitable for 3 mm and 4 mm thick knives.

SETTING AND MEASURING

NZ	M01	Clearance angle checking guage
----	-----	--------------------------------

COOLANT SYSTEM

NXT	138	Semi-synthetic grinding fluid in concentrate form. Supplied in 5 litre containers Note : To be diluted at 50 : 1 ratio
NXT	145	Anti-bacterial solution concentrate for cleansing coolant system when replacing grinding fluid. Supplied in 5 litre containers

FULL HEALTH AND SAFETY DATA SHEETS ARE AVAILABLE FOR NXT 138 / 145 FLUIDS.

T30	49102	Hand held refractometer for measuring concentration of grinding fluid.
-----	-------	--



APPENDIX

A6

SUGGESTED SPARES FOR NZ MACHINES

Note : Consumable items such as grinding wheels and coolant fluids are included in Appendix A5.

<u>Qty</u>	<u>Part No.</u>	<u>Description</u>
<u>Table assembly</u>		
1	NHP 210	Bellows
1	NHP 217	Gasket
1	NHP 346	Arbor shell
2	NXU S0033	Limit switch
1	T30 69116	'O' ring
1	T30 77355	Timing belt
4	T30 05347	Linear bearing
2	T30 05321	Thrust bearing
2	K05 31347	FI bush 12 x 18 x 20 long
2	K06 01120	Ball bearing 6003-2RS
2	K06 01316	Ball bearing 63001-2RS
<u>Indexing unit</u>		
1	NHP 335	Torsion spring
2	NHP 343	Compression spring
1	K05 31359	Bush 25 x 32 x 25 long
2	K06 01151	Bearing 6009-2RS
1	T30 05113	Bush 25 x 32 x 25 long
1	T30 05114	Bush 30 x 38 x 25 long
1	T30 05125	Glycodur bush
1	T30 73208	Seal
2	T30 05130	Glycodur FI bush



APPENDIX

A6

Grinding head

1	NHP 134	Flat drive belt
1	NHP 140	Knife guide No.4
1	NHP 408	Rise and fall nut
1	NHP 411	Rise and fall screw
1	NHP 459	Rubber flap for wheel guard
1	NHP 461	Rubber flap for backplate
2	T30 05124	Bush 25 x 30 x 25 long
1	T30 05305	Pair of A/C bearings
4	T30 05322	Linear bearing
1	K06 01126	Bearing 6006-2RS
2	K06 04133	Thrust bearing 51101

Infeed mechanism

2	NHP 417	Adjusting nut
1	NHP 433	Gear 150T
1	NHP 435	Spring
2	T30 05103	Bush 6 x 10 x 16 long
1	T30 05107	Bush 15 x 19 x 25 long
2	T30 05123	Bush 16 x 20 x 20 long
2	T30 05321	Thrust bearing 51102
2	T30 05358	Flange bearing
2	T30 17165	Solenoid
1	T30 77355	Timing belt
1	T30 25209	Gear 48T

Coolant system

1	T30 49205	Magnet
---	-----------	--------

Electrical system

1	NX S1203	2 amp fuse
4	NX S1204	6 amp fuse
4	K12 04350	16 amp fuse
3	T30 17170	20 amp fuse
1	NXU S0105	25 v 40 w Worklamp bulb
4	T30 17220	24 v Lamp (pushbuttons)



APPENDIX

Clearance Angle Charts For Alternative Knife Guides

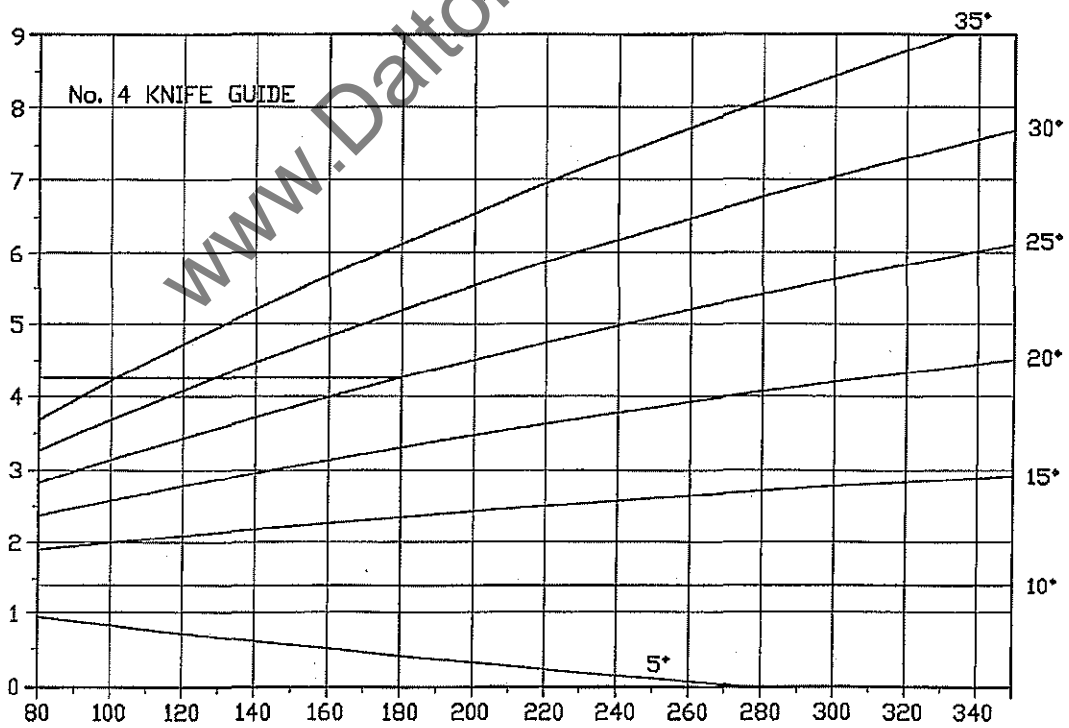
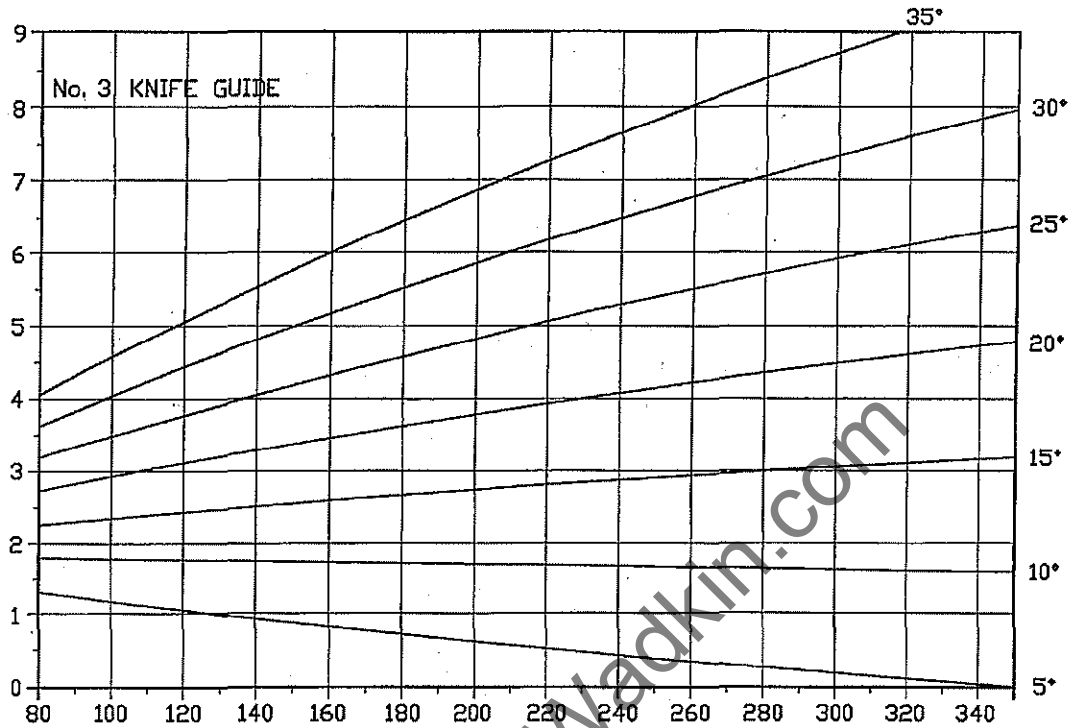



APPENDIX

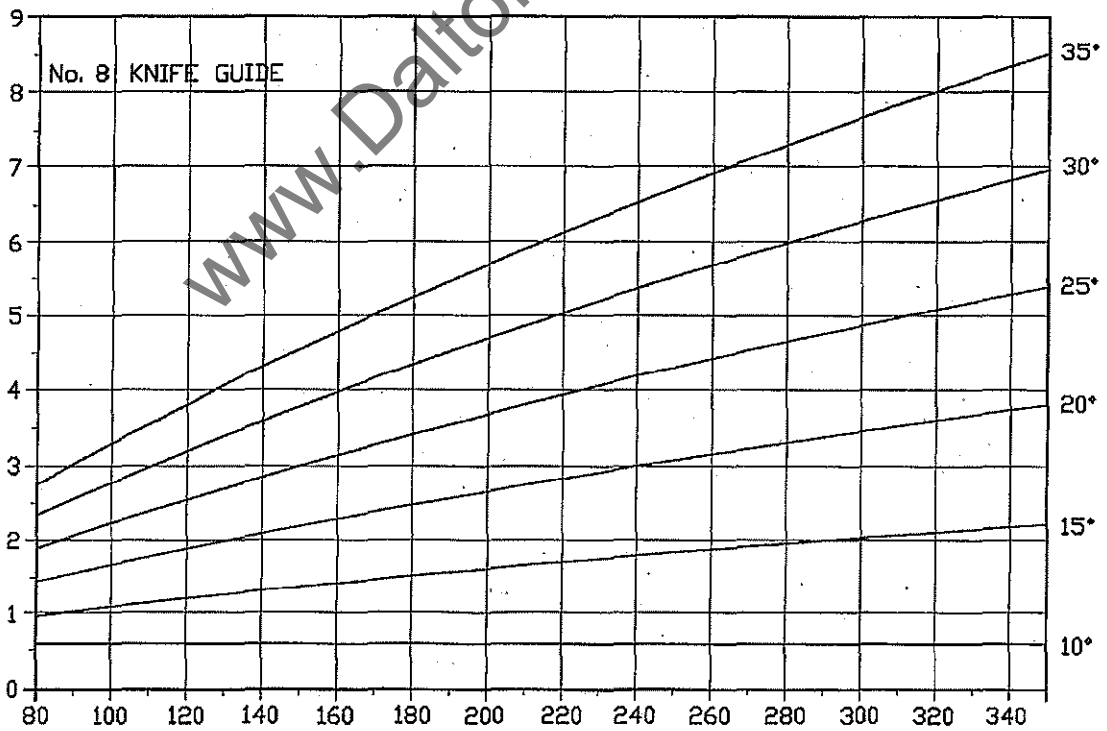
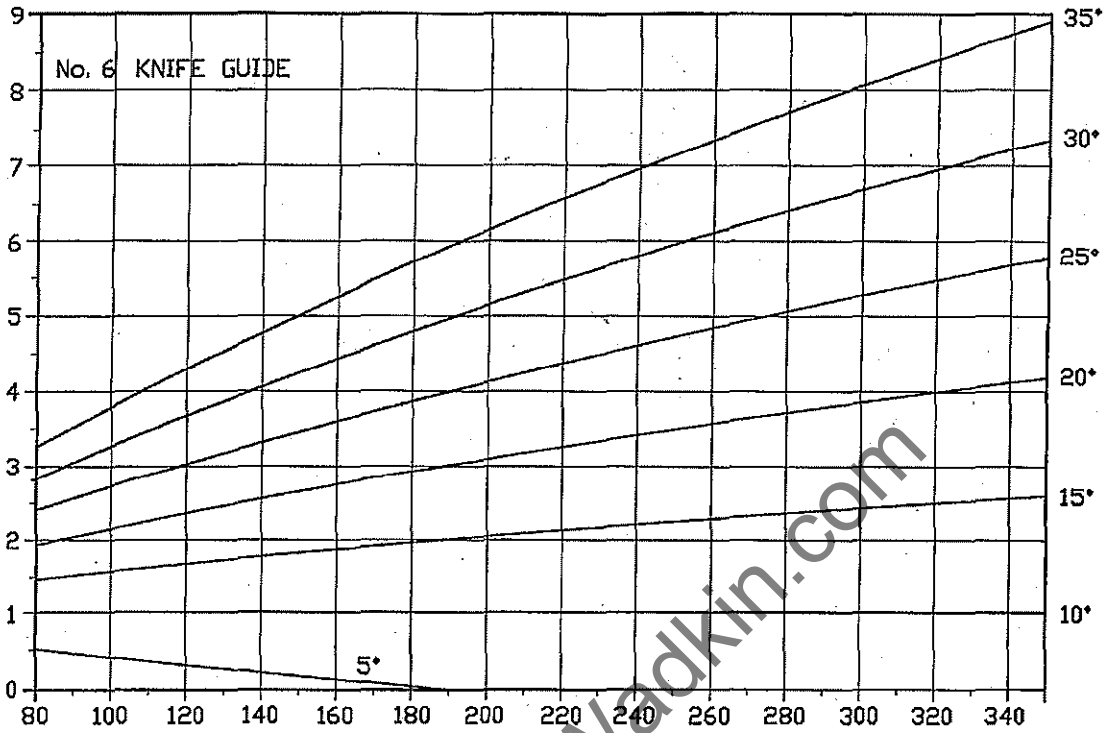



APPENDIX

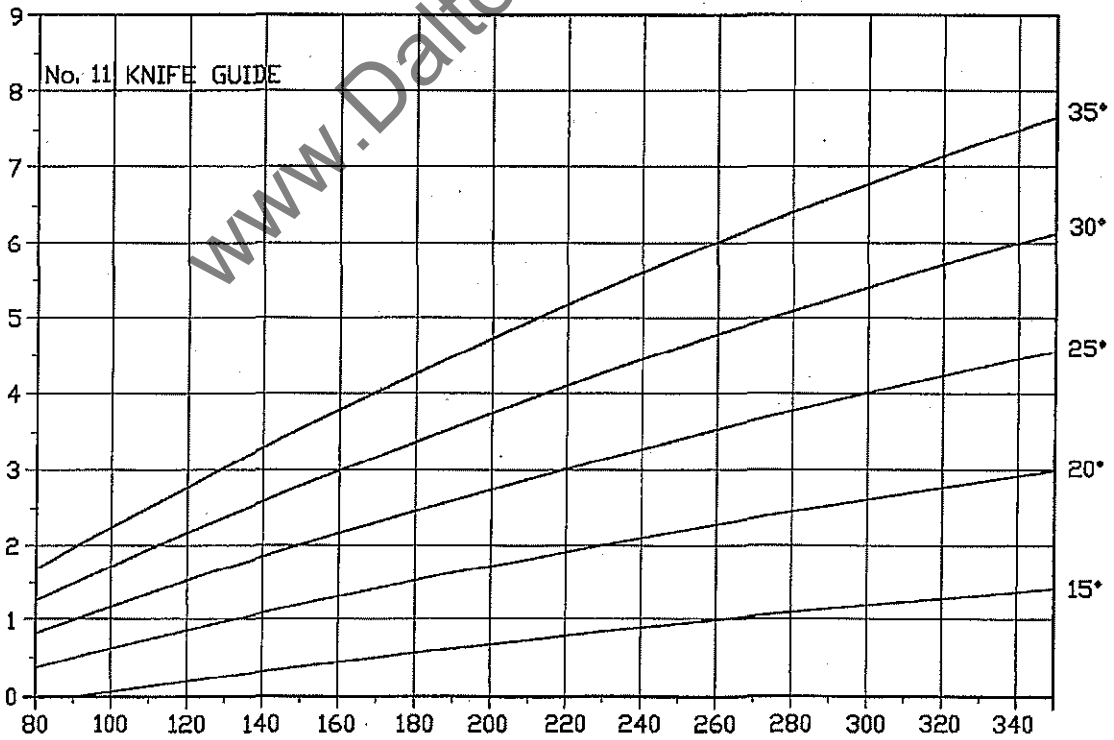
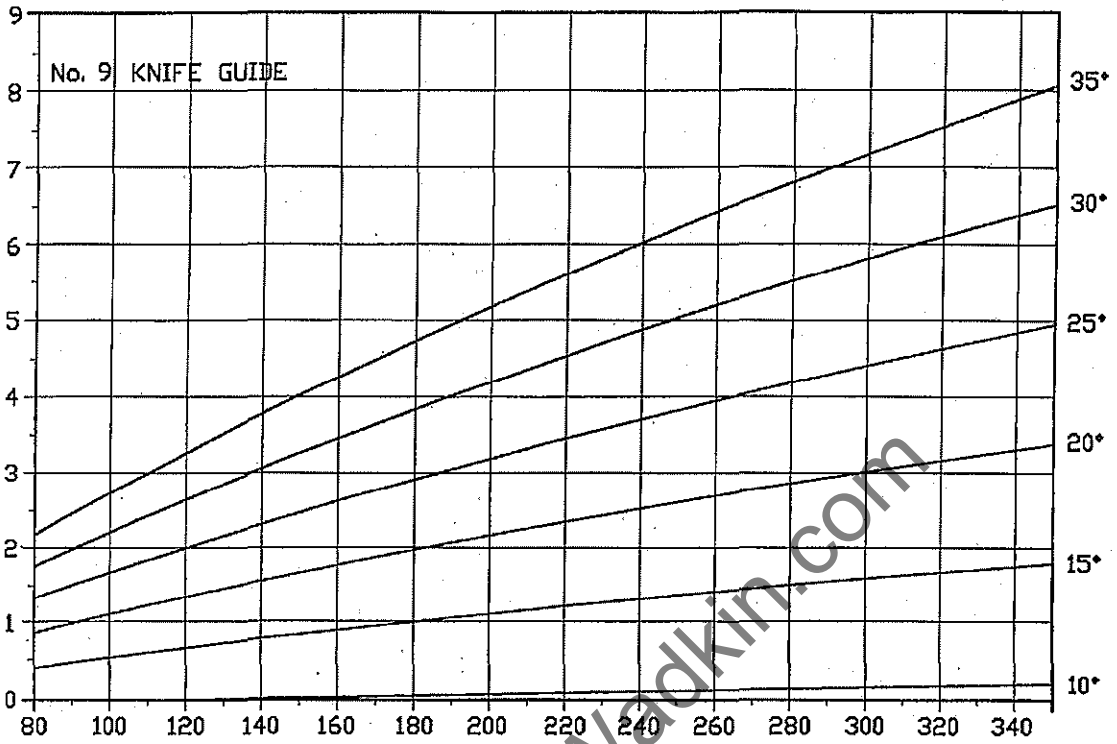



APPENDIX

ELECTRICAL CIRCUIT DIAGRAM

www.DaltonsWadkin.com

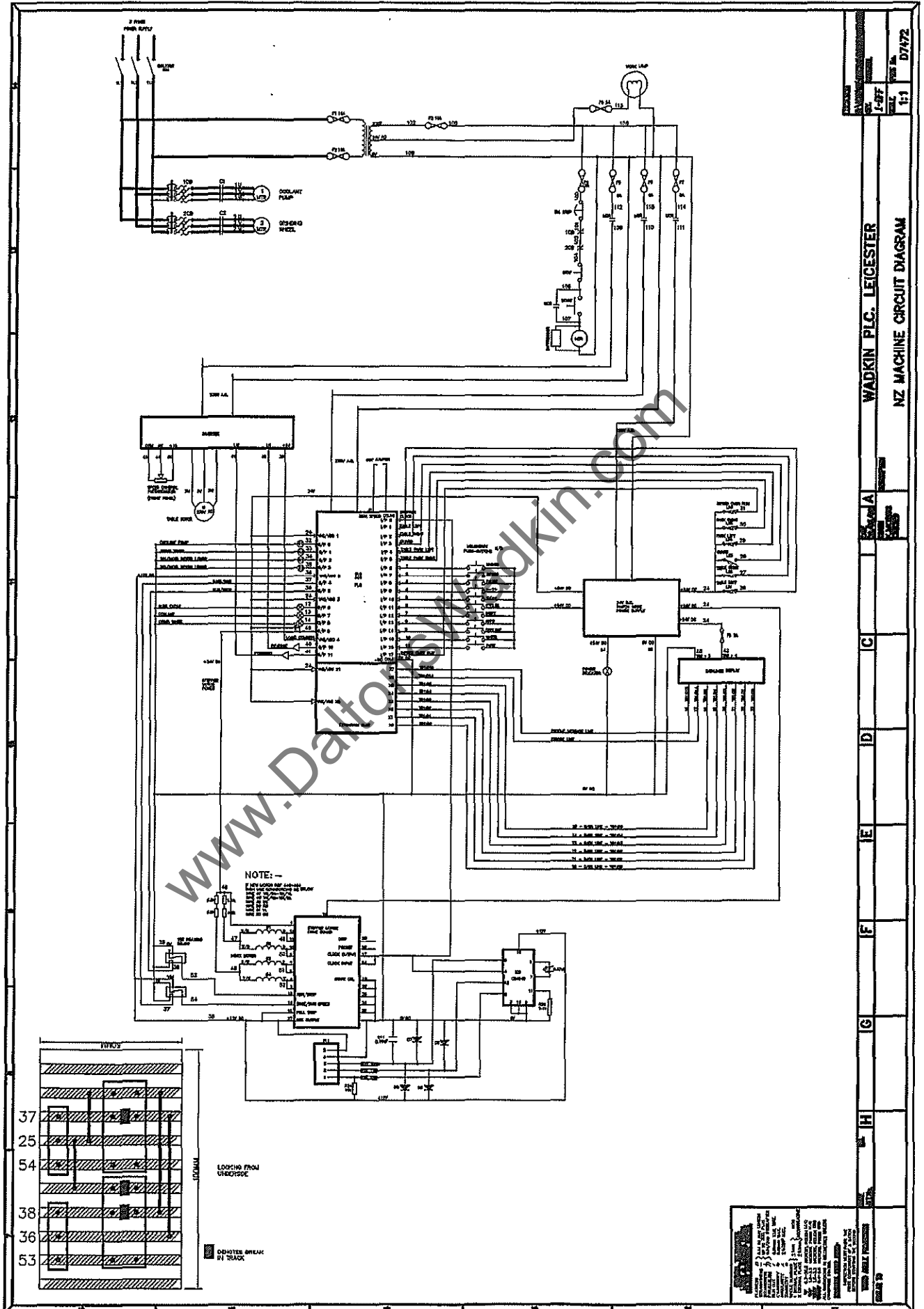

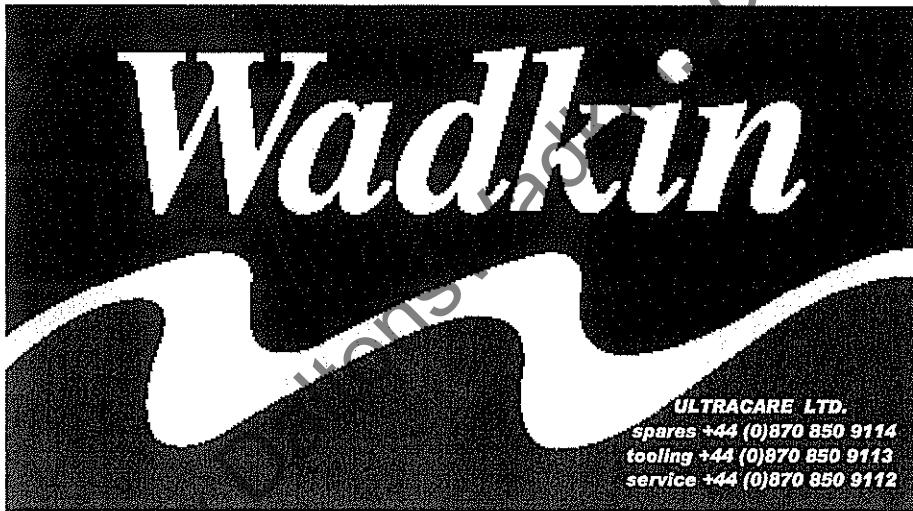

ULTRACARE LTD.
spares +44 (0)870 850 9114
tooling +44 (0)870 850 9113
service +44 (0)870 850 9112