

THROUGH FEED
STRAIGHTENING MOULDER
MODEL GA

www.DaltonsWadkin.com

INSTRUCTION BOOK 1390

"WADKIN" THROUGH FEED STRAIGHTENING MOULDER - MODEL "GA"

www.DaltonsWadkin.com

INSTRUCTION MANUAL NO: 1390

SAFETY RULES

THE SAFE OPERATION OF WOODWORKING MACHINERY REQUIRES CONSTANT ALERTNESS AND CLOSE ATTENTION TO THE WORK IN HAND.

CAREFULLY READ INSTRUCTION MANUAL BEFORE OPERATING MACHINE.

DO NOT OPERATE WITHOUT ALL GUARDS AND COVERS IN POSITION.

BE SURE MACHINE IS ELECTRICALLY EARTHED - GROUNDED.

REMOVE OR FASTEN LOOSE ARTICLES OF CLOTHING SUCH AS NECKTIES ETC, CONFINE LONG HAIR.

REMOVE JEWELLERY SUCH AS FINGER RINGS, WATCHES, BRACELETS ETC.

USE SAFETY FACE SHIELD, GOGGLES, OR GLASSES TO PROTECT EYES AND OTHER PERSONAL SAFETY EQUIPMENT AS REQUIRED.

STOP MACHINE BEFORE MAKING ADJUSTMENTS OR CLEANING CHIPS FROM WORK AREA.

BLUNT CUTTERS OFTEN CONTRIBUTE TO ACCIDENTS. AN EFFICIENT MACHINIST KNOWS WHEN RE-SHARPENING IS NECESSARY, BUT IF THERE IS RELUCTANCE TO SPEND TIME ON GRINDING AND RE-SETTING, THE CUTTERS MAYBE RUN BEYOND THEIR EFFICIENT LIMITS AND INSTEAD OF CUTTING EFFICIENTLY AND SMOOTHLY, THEY TEND TO CHOP AND SNATCH AT THE WOOD. THIS NOT ONLY INCREASES THE RISK OF ACCIDENTS BUT ALSO LOWERS THE QUALITY OF WORK.

CUSTOMERS ARE STRONGLY ADVISED TO USE AT ALL TIMES, HIGH TENSILE STRENGTH CUTTER BLOCK BOLTS WHICH SHOULD BE TENSIONED BY MEANS OF A TORQUE SPANNER.

KEEP THE FLOOR AROUND THE MACHINE CLEAN AND FREE FROM SCRAPS, SAWDUST, OIL OR GREASE TO MINIMISE THE DANGER OF SLIPPING.

ALWAYS QUOTE MODEL AND MACHINE NUMBER WHEN ORDERING SPARES

www.DaltonsWadkin.com

SPARE PARTS

SHOULD SPARE PARTS BE REQUIRED DUE TO BREAKAGE OR WEAR, FULL PARTICULARS INCLUDING MACHINE AND TEST NUMBER MUST BE GIVEN, THIS INFORMATION IS ON THE NAMEPLATE ATTACHED TO THE FRONT OF THE MACHINE AND SHOULD BE FORWARDED TO THE SERVICE MANAGER.

Wadkin PLC	
GREEN LANE WORKS, LEICESTER, ENGLAND	
MACHINE NO.	
TEST NO.	
VOLTS	3- HZ
AMPS	MAX
"GA"	

SAMPLE TYPE ORDER

MACHINE

"GA"

MACHINE NO:

TEST NO:

PARTS REQUIRED

- | | | |
|---|---|-------------------------------------|
| 1 | - | M10 x 50mm. long screwed stud |
| 1 | - | M10 size. bright mild steel washers |
| 1 | - | Raising screw |

Wadkin PLC., Green Lane Works. Leicester LE5 4PF

Telephone: 0533 769111
Cables: Woodworker Leicester
Telex: 34646 (Wadkin Leicester)

A T T E N T I O N .

THIS MACHINE CAN BE DANGEROUS IF IMPROPERLY USED.

ALWAYS USE GUARDS.

KEEP CLEAR UNTIL ROTATION HAS CEASED.

ALWAYS OPERATE AS INSTRUCTION MANUAL AND IN ACCORDANCE WITH GOOD PRACTICE.

R E A D T H E I N S T R U C T I O N M A N U A L .

N O T E :

THIS MACHINE, WHEN UNDER WORKING CONDITIONS, WILL PRODUCE A NOISE LEVEL IN EXCESS OF 90dB(A), AND IN ITS PROPER USE OPERATORS MUST WEAR EAR PROTECTORS. WADKIN PLC, ARE ABLE TO OFFER ENCLOSURES ON REQUEST, WHICH, IN ADDITION TO BEING AN OVERALL SAFETY FEATURE WILL GIVE A CERTAIN DEGREE OF SOUND ATTENUATION.

HOWEVER, WHEN USING THE MACHINE FITTED WITH AN ENCLOSURE, THE NOISE LEVELS MAY NOT BE REDUCED SUFFICIENTLY UNDER ALL CIRCUMSTANCES TO COMPLY WITH THE REQUIREMENTS OF THE WOODWORKING MACHINERY REGULATIONS 1974, AND OPERATORS OF THE MACHINE MAY BE REQUIRED TO WEAR EAR PROTECTORS.

IT IS RECOMMENDED THAT ALL PERSONNEL INVOLVED WITH THE MACHINE ARE ACQUAINTED WITH THE WOODWORKING MACHINES REGULATIONS, 1974 AND ALSO BOOKLET NO:41 - SAFETY IN THE USE OF WOODWORKING MACHINES - THE LATTER IS ISSUED BY THE DEPARTMENT OF EMPLOYMENT AND AVAILABLE FROM HER MAJESTY'S STATIONERY OFFICE.

I M P O R T A N T .

IT IS OUR POLICY AND THAT OF OUR SUPPLIERS TO REVIEW CONSTANTLY THE DESIGN AND CAPACITY OF OUR PRODUCTS. WITH THIS IN MIND WE WOULD REMIND OUR CUSTOMERS THAT WHILST THE DIMENSIONS AND PERFORMANCE DATA CONTAINED HEREIN ARE CURRENT AT THE TIME OF GOING TO PRESS, IT IS POSSIBLE THAT, DUE TO THE INCORPORATION OF LATEST DEVELOPMENTS TO ENHANCE PERFORMANCE, DIMENSIONS AND SUPPLIES MAY VARY FROM THOSE ILLUSTRATED.

ALWAYS QUOTE MODEL, MACHINE NO: AND SECTION NO: WHEN ORDERING SPARES

INDEX "GA" MACHINE

Principal Dimensions and Capacities	page 1
Universal Throughfeed Planer Moulder - Model "GA"	page 2
Illustration - Universal Throughfeed Planer Moulder - Standard Machine	page 4
Contents of Manual	page 5
Sequence of Heads	page 6
INSTALLATION OF MACHINE	
Installation of Machine	page 7
ADJUSTMENTS	
Structure of the Surfacers	page 11
Short Infeed Table	page 12
* Outfeed Rise and Fall Table	page 12a
Surfacer - First Bottom Horizontal Head	page 13
The Fence Side Vertical Spindles	page 14
The Near Side Vertical Head	page 16
Illustration - Showing Position of 'Green' indicator light / Air pressure gauge for Random Side Head	page 18
* Near Side Head with Random width selection	page 19
* Electronic Positioning - Dial - A - Size	page 20
* Electronic Positioning with Programmable Memory to Nearside and Top Head	page 21
Top Horizontal Spindle	page 22
* Outboard bearing fitted to Top / Additional Head	page 22a
Second Bottom Horizontal Spindle	page 24
Universal Head in the Near Side Vertical Mode	page 25
Universal Head as a Bottom Horizontal Spindle	page 26
Universal Head as a Top Horizontal Head	page 27
Universal Head as a Near Side Head	page 28
* Additional Bottom / Top Heads close coupled	page 28a
* Throating Head	page 28b
* The Canting Fence Side Head	page 29
* Illustration - Rear view of machine showing gear drive to Top and Bottom feed rolls	page 29a
* Illustration - View showing drive to Top and Bottom Infeed rolls	page 29b
* Illustration - View showing drive to Top and Bottom feed rolls at Universal head	page 29c
* WHERE FITTED	
January, 1985	

THE FEEDWORKS

The Feedworks	page 30
* Feedworks - Typical Pneumatic Circuit to Feedrolls	page 32
* Illustration - Intermediate Feed Rolls - Alternative Positions shown	page 32a

PUTTING THE MACHINE INTO SERVICE

Putting the Machine into Service	page 33
Surface Planing	page 34
Edge Trimming - Jointing	page 35
First Vertical Near Side Head / Second Vertical Fence Side Head	page 36
Top Horizontal Spindle / Bottom Horizontal Spindle	page 37
Universal Spindle in the Bottom Horizontal Mode / Top Horizontal Mode / Near Side Vertical Mode / Feedworks	page 38

SAFETY DEVICES AND MACHINE TEST AND TRIAL RUN

The handling of the safety devices / circular sawblades	page 39
---	---------

MACHINE TEST AND TRIAL RUN

Machine test and trial run	page 40
----------------------------	---------

MAINTENANCE OF MACHINE

Maintenance of the machine	page 41
Regular cleaning of the machine	page 42
Lubrication of the machine	page 43
Approved lubricants	page 43a
Changing the bearing of the cutterblock spindle / preparation prior to fitting the bearings	page 44
Replacement of parts associated with the motor pulleys	page 45
Re-fitting the pulleys and taper lock bushes	page 46
Maintenance of the cutters and tool holders	page 47
Elimination of vibration during works / adjustment of the belt	page 48
Maintenance of variable speed pulleys	page 49

ELECTRICAL FAULTS

Electrical faults	page 51
-------------------	---------

BELTS AND PULLEYS

Belt and pulley charts - Electrical frequency of 50 HZ.	page 54
Belt and pulley charts - Electrical frequency of 60 HZ.	page 56

* WHERE FITTED

January, 1985

* Pneumatic circuit - Sound enclosures 170 / 220 (GRP)	page 57a
BEDPLATE CHARTS	
Bedplate charts	page 58
* Air bed control unit - "170"	page 59
* Pneumatic circuit for Air Bed - "170"	page 60
* Air bed control unit - "220"	page 61
* Pneumatic circuit for Air Bed - "220"	page 62
PRESSURES AND CHIPBREAKERS	
Top head chipbreaker, pressure and extraction hood	page 63
Mounting for Top ped OR Roller pressure after Top head	page 66
Top pad pressure unit	page 67
Top roller pressure unit	page 68
Mounting for Top pad OR Roller pressure before Top head	page 69
Single side roller pressure opposite First Fence side head	page 70
Single side roller pressure before First Bottom head	page 71
Feedroll unit after Top head OR between Second Bottom head and Universal head pneumatic OR spring loaded chain driven	page 72
Drive to chain driven feedworks	page 75
Feedroll driving chains tensioning mechanism	page 77
"SIMPLABELT" variable speed drive unit - Type 11.332.16.16.2	page 79
CUTTING HEADS - PARTS AND ILLUSTRATIONS	
First Bottom Head	page 81
Non-Canting Fence side Head carriage unit adjusting mechanism - including dust extraction hood	page 83
Non-Canting Near side head carriage unit adjusting mechanism - including dust extraction hood	page 85
Top Head - Including power rise and fall	page 87
Adjustments for Second Bottom Head and Third Bottom Head	page 90
Universal Head - Adjusting Mechanism	page 93
SPINDLE UNITS	
Bottom Head spindle unit - 40mm. dia. Square Shoulder	page 95
Fence Side Head spindle unit - 40mm. dia. Square Shoulder	page 97
Near Side Head spindle unit - 40mm. dia. Square Shoulder	page 99
Top Head spindle unit - 40mm. dia. Square Shoulder	page 101
Universal Head spindle - 40mm. dia. Square Shoulder	page 103
* WHERE FITTED	

January, 1985

SPARES

Variable speed drive (with right angled adjuster) Size 16 (gear driven feed works / Intermediate vee belt drive - Gear driven feedworks)	page 105
Variable speed drive - Size 20 (Gear driven feedworks) / intermediate vee belt drive - Gear driven feedworks	page 106
Bearings and seals	page 107
Procedure for fitting safety drive collars for hydrofix cutterblocks and hydrogrip sleeves	page 108

PRECISION SPINDLES (9000 RPM) OR AS SPECIFIED

Bottom Head Spindle Unit 40 mm. dia. Square Shoulder	page 111
Fence Side Head Spindle Unit 40 mm. dia. Square Shoulder	page 113
Near Side Head Spindle Unit 40 mm. dia. Square Shoulder	page 115
Top Head Spindle Unit 40 mm. dia. Square Shoulder	page 117
Top Head Spindle Unit 40 mm. dia. Square Shoulder	page 118
Stock Recorder *	page 119

* WHERE FITTED

January, 1985

PRINCIPAL DIMENSIONS AND CAPACITIES

"WADKIN" Universal Through Feed Planer Moulder - Model "GA"		4 to 7 spindles
Maximum size of timber admitted	180mm. x 130mm.)	GA 170
Maximum size of finished work	170mm. x 120mm.)	
Maximum size of timber admitted	230mm. x 130mm.)	GA 220
Maximum size of finished work	220mm. x 120mm.)	
Feed speed infinitely variable	6.0 to 28m/min.	OPTIONAL 6.0 to 36m/min.
Control adjustment of Feed rolls and all pressures.		
Limit switch at the extremities of the raise and fall beam.		
Diameter of feed rolls	140mm. maximum width 50mm. sectional - 2 x 20mm. + 1 x 10mm.	
Diameter of cutterblock spindles	40mm.	
Speed of cutterblock spindles	6000 RPM.	
Maximum diameter of cutterblock	180mm. (Second fence side head 190mm.)	
Minimum diameter of cutterblock	100mm.	
All cutterblock spindles have vertical and horizontal adjustments with the exception of the First bottom horizontal head which has only vertical adjustment.		
Maximum vertical adjustment of side heads	40mm.	
Maximum horizontal adjustment of horizontal heads	30mm.	
Maximum straightening	10mm.	
Maximum cut on first bottom horizontal head	10mm.	
Maximum cut on first fence side vertical head	10mm.	
Length of infeed table	2 metres. (STD) OPTIONAL 2.5 METRES	
OUTPUT OF MOTORS		
* Feed motor Models 1 - 1S 2 - 2S 5 & 6	} Chain driven feedworks	4.0KW
* Feed motor Models 1U - 2U 1SU - 2SU 5U - 6U		
* Gear driven feedworks	2.2KW OR 4.0KW	
Rise and fall motor for beam	0.37KW	
All head motors	4.0KW (STD) OPTIONAL 5.5KW 7.5KW 11.0	

Machine complete with control gear, wiring and motors. Included with the machine dust hoods, set of spanners and Instruction Book.

NOTE: EXTRA CUTTER SPINDLES ARE AVAILABLE.

UNIVERSAL THROUGHFEED PLANER MOULDER - MODEL "GA"

1. Adjustable Infeed Table.
2. Adjustable Infeed Fence.
3. Infeed Fence Adjustment Lever.
4. Electrical Control Gear Cavity.
5. Electrical Push Button Control Console.
6. Infeed Table Adjustment Lever.
7. Hand Lubricating Pump. (if fitted).
8. Locking Lever for First Bottom Horizontal Head Vertical Adjustment.
9. Handwheel for Vertical Adjustment of First Bottom Horizontal Head (Surfacing).
10. Square Shaft Extension for Lateral Adjustment of First Fenceside Vertical Head.
11. Square Shaft Extension for Vertical Adjustment of First Fenceside Vertical Head.
12. Locking Levers for Lateral and Vertical Adjustment of First Fenceside Vertical Head.
13. Square Shaft Extension for Lateral Adjustment of Nearside Vertical Head.
14. Square Shaft Extension for Vertical Adjustment of Nearside Vertical Head.
15. Locking Levers for Lateral and Vertical Adjustment of Nearside Vertical Head.
16. Square Shaft Extension for Lateral Adjustment of second Fenceside Vertical Head.
17. Locking Levers for Lateral and Vertical Adjustment of Second Fenceside Vertical Head.
18. Square Shaft Extension for Vertical Adjustment of Second Fenceside Vertical Head.
19. Side Pressure Adjustment.
20. Lock Lever for Vertical Adjustment of First Top Horizontal Head.
21. Handwheel for Lateral Adjustment of First Top Horizontal Head.
22. Clutch Operating Lever for Automatically raising and lowering First Top Horizontal Head.
23. Handwheel for Vertical Adjustment of First Top Horizontal Head.
24. Handwheel for Lateral Adjustment of Second Bottom Horizontal Head.
25. Handwheel for Vertical Adjustment of Second Bottom Horizontal Head.
26. Locking Lever for Vertical Adjustment of Second Bottom Horizontal Head.
27. Locking Lever for Vertical Adjustment of Universal Head.
28. Square Shaft Extension for Lateral Adjustment of Universal Head.
29. Square Shaft Extension for Canting Adjustment of Universal Head.
30. Square Shaft Extension for Vertical Adjustment of Universal Head.

UNIVERSAL THROUGHFEED PLANER MOULDER - MODEL "GA".....CONTD

31. Locking Lever for Lateral Adjustment of Universal Head.
32. Handwheel for Vertical Adjustment of Outfeed Table.
33. Locking Lever for Vertical Adjustment of Outfeed Table.
34. Side Pressure Adjustment for Outfeed Table.
35. Outfeed Table.
36. Feedroll.
37. Pneumatic pressure Cylinder for Feedroll. (Optional extra).
38. Hand Operated Height Screws for Feedroll.
39. Overhead beam carrying Feedrolls.
40. Top Roller Pressure over Universal Head.
41. Hand Operated Height Screws for Feedrolls.
42. Push Button Control Station containing Raise and Lower Buttons for Overhead Beam and Top Horizontal Head, Feed Button and Master "STOP" Button.
43. Top Pad Pressure after Top Horizontal Head.
44. Chipbreaker for Top Horizontal Head.
45. Top Roller Pressure after Second Fenceside Vertical Head.
46. Top Roller Pressure between Side Vertical Heads.
47. Infinitely Variable Speed Feed Motor and Gear Reduction Unit.
48. Screw for Feedroll.
49. Air Pressure Gauges and Air Inlet and Outlet Unions.
50. Feedrolls before First Bottom Horizontal Head.

May, 1987

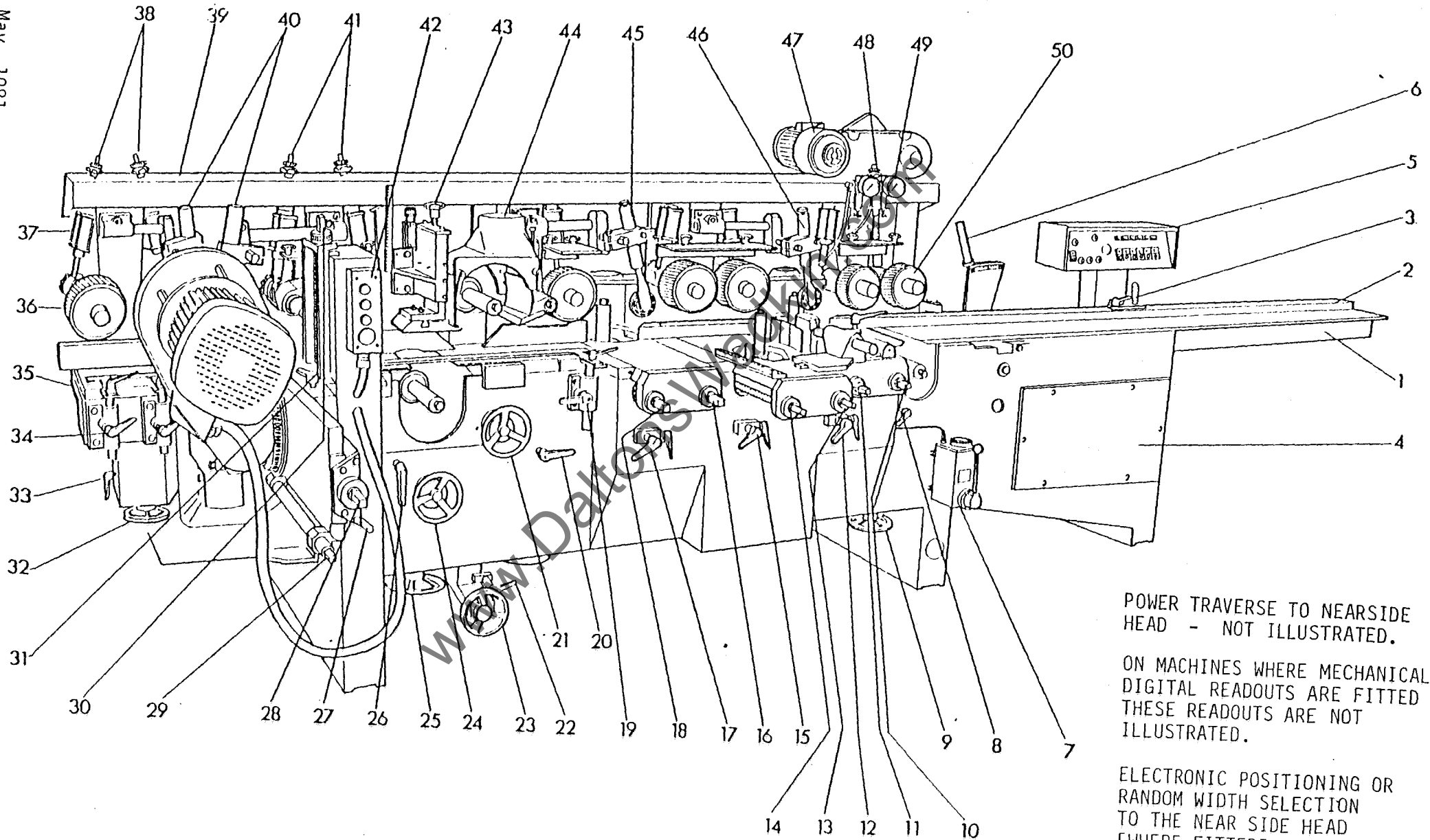

POWER TRAVERSE TO NEARSIDE HEAD - NOT ILLUSTRATED.

ON MACHINES WHERE MECHANICAL DIGITAL READOUTS ARE FITTED THESE READOUTS ARE NOT ILLUSTRATED.

ELECTRONIC POSITIONING OR RANDOM WIDTH SELECTION TO THE NEAR SIDE HEAD [WHERE FITTED] IS NOT ILLUSTRATED.

UNIVERSAL THROUGHFEED PLANER MOULDER MODEL GA.
 (STANDARD MACHINES)

CONTENTS OF MANUAL

www.DaltonsWadkin.com

1.	Principal Dimensions and Capacities	page 1
2.	Delivery and Siting of the Machine	page 7
2.1	Loading and unloading: Details of the weight.	page 7
2.2	Method of transport (mounting of machine for shipping).	page 7
2.3	Method of unpacking, the cleaning and assembling and resiting	page 7-8
2.4	Foundation Plan.	page 8
2.5	Space required for Machine.	page 8
2.6	Service supplies.	page 8
2.6.1	Electrical supply.	page 8-9
2.6.2	Pneumatic Supply.	page 9
2.6.3	The Exhaust (Dust Extraction) Connections.	page 9
2.7	The Schematic Diagrams for Electrics, Pneumatics.	page 9
2.8	Information of regulations, against accidents, rules of conduct for safety and B.S.S. and Electrical Standards.	page 9
3.0	Placing the Machine in Service	page 10
3.1	Service Instructions	page 10
3.2	Lubrication procedure before putting into service	page 33
3.3	Control of speeds to movements	page 33
3.4	Fitting and Adjusting the cutterblocks.	page 33
3.5	Machine adjustments.	page 34
3.6	The use of the Safety Guards.	page 39
3.7	Machine Test and Trial Run.	page 40
4.0	Maintenance of the Machine.	page 41
4.1	Cleaning of the Machine	page 42
4.2	Lubrication of the Machine.	page 43
4.3	Replacement of parts associated with the Motor Pulleys.	page 45
4.4	Maintenance of the cutterblocks and tool holders (cutterblock spindles)	page 47
4.5	Elimination of Vibration.	page 48
4.6	Maintenance of variable speed pulleys.	page 49
4.7	Electrical faults.	page 51-53

SEQUENCE OF HEADS

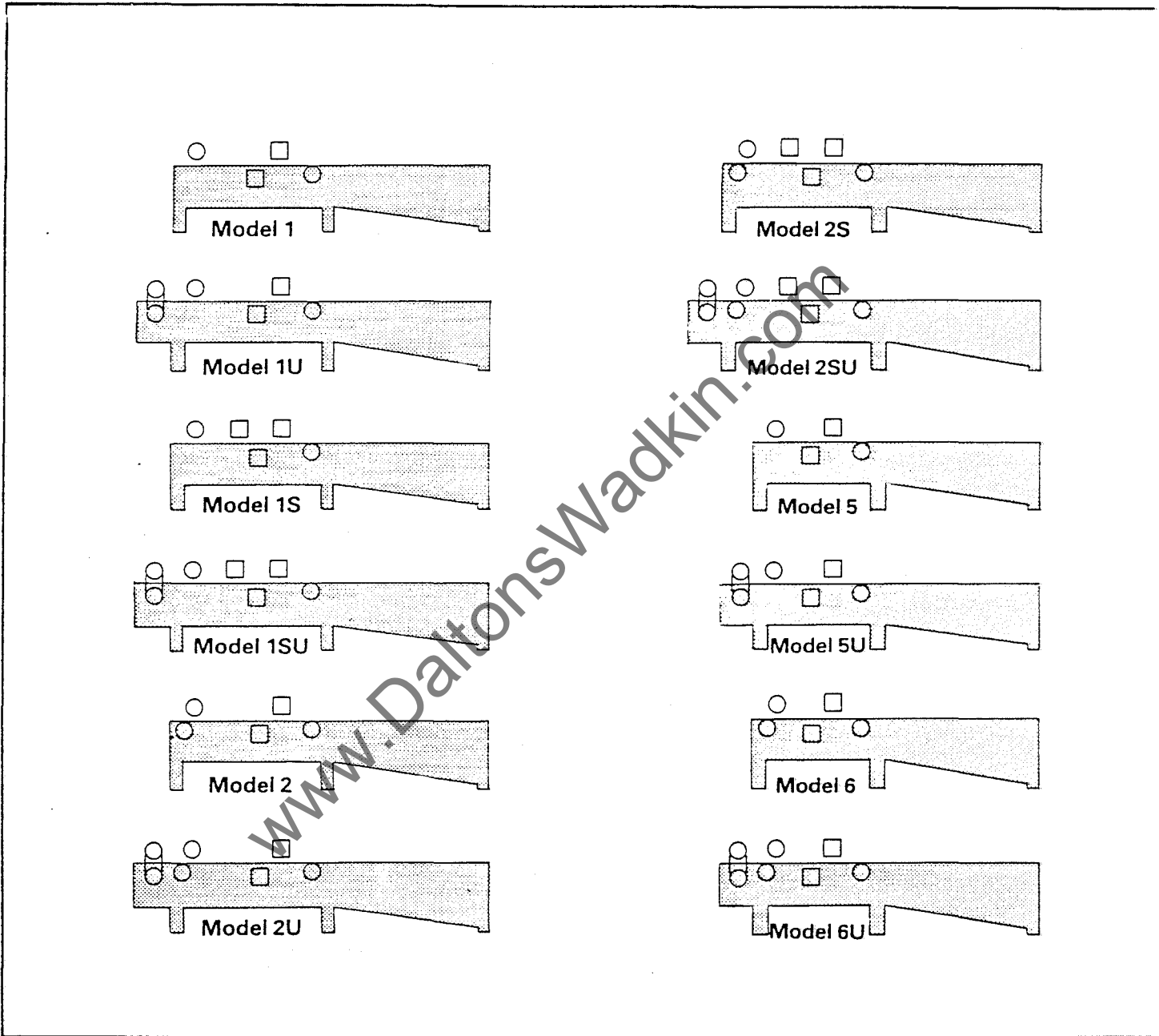

2. Delivery and Location of the Machine

2.1 Loading and unloading Instructions. Take careful note of the weight.

UNLOADING BY CRANE

Having verified the weight of the machine.

To lift the machine, place two 45mm. diameter steel rods 1.2 metres long in the holes provided in the machine body. To gain access to one of the holes it will be necessary to remove the cover (illustrated) from the rear of the machine.

Carefully place two short slings on the crane hook. Keep these as wide apart as possible by inserting wooden chocks between the machine body and the slings to avoid damaging the machine.

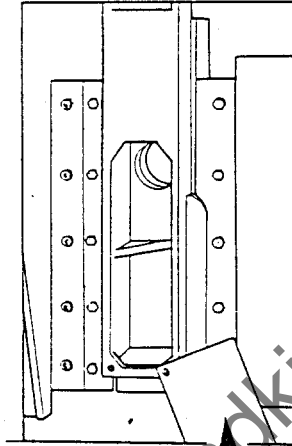

Remove this cover at rear of the machine to gain access to one of the lifting holes.

2.2 Moving Instructions

In the process of moving the machine avoid jolting OR vibrating it. The machine can be located on wooden plinths if the ground is flat and moved by rollers instead of lifting.

IMPORTANT:

IN THE COURSE OF MOVING THE MACHINE HAS A TENDENCY TO TILT TOWARDS THE BACK (TOWARDS THE ELECTRIC MOTORS AND THE ATTENDANT MOTOR MOUNTING BRACKETS).

2.3 Method of Unpacking, cleaning, assembling and re-siting.

Undo the packing and make sure that damage has not occurred during transit, undo the case of accessories and ascertain that the machine is complete.

CLEANING.

Before levelling the machine, carefully remove the anti-rust material particularly from the bright parts.

Clean with petrol and soft rag.

Do not use a substitute - it may precipitate an explosion.

Smear a light coat of grease on the bright parts.

2.3 Method of Unpacking, cleaning, assembling and re-siting contd

LOCATION OF THE MACHINE

To obtain the best results from the machine it is important that the floor on which the machine is to stand has been prepared and is dry. Level the machine from the middle of the bed between the adjustable screw supports by the help of a spirit level.

Place under the adjustable screws the steel plates supplied with the machine.

SUGGESTED LEVELLING AIDS

A straight edge 2 metres long.

Feelers (thickness gauges) 0.05, 0.10, 0.15 and 0.2mm.

An Engineer's Spirit Level

A rule 0.2mm to 1 metre long.

LEVELLING LONGITUDINALLY

Rest the straight edge on the table. Check any variation of level and move the level lengthwise. Set the machine level by utilising the adjusting screws in the feet of the machine. Check with 'Feelers'.

The difference in the level longitudinally along the length of the table should not deviate more than 0.2mm. The table of the surfacer should be aligned with the machine bed and can be adjusted slightly in front of the planing spindle. Maximum tolerance 0.1mm. in 1600mm.

LEVELLING TRANSVERSELY

Place the spirit level across the table at right angles to the fence and repeat this action at intervals of 800mm. Total variation should not exceed one graduation on the scale along the whole length of the machine.

2.4 The Foundations

The size of the foundations depends upon the specific machine model, format of the heads and disposition of the exhaust outlets.

If the floor consists of 100mm - 150mm. (4 to 6 inches) solid concrete, no special foundation is necessary. M12 "HILTI" type holding down bolts may be used (these are not supplied with the machine).

NOTE: MACHINE MUST BE BOLTED DOWN

2.5 The floor area

See foundation Plan.

2.6 The supply system

2.6.1 The electrical supply

The Customer is responsible for an adequate electrical supply.

The machine is delivered with its complete electrical equipment. The electrical connection diagram and the schematic diagram are found in the electrical control cubicle of the machine.

All that is required is to connect the power supply to the disconnect (Isolator) switch at the electrical control cubicle.

2.6.1 The electrical supply.....contd

POINTS TO NOTE WHEN CONNECTING THE POWER SUPPLY

- 1) Check the voltage, phase and frequency with those on the machine nameplate.
- 2) Check that the main fuses are of the correct capacity in accordance with the machine nameplate.
- 3) Connect the incoming supply leads to the appropriate terminals.
- 4) Check that all connections are sound.
- 5) Check that the spindle rotation is correct (when looking from the front of the machine the feed rolls should rotate in a clockwise direction). To reverse the rotation - reverse any two of the line lead connections at the incoming supply.

IMPORTANT: ANY MODIFICATIONS SHOULD BE CARRIED OUT BY AN ELECTRICIAN.

2.6.2 Pneumatic Branch Circuits (special equipment)

The machine is equipped with feedrolls with pneumatic pressures. The number of outlets are shown on the pneumatic circuit diagram and foundation plan. Make the connections by linking up the union nuts of the air pipes.

Size of Air Inlet connection is 1/4 B.S.P. FEMALE

The size of the air pipes is 8mm. O.D. x 5mm. I.D.

Pressure = 6 bar (atm)..See....Page 30....For feedroll pressures.

The air consumption is approximately 200 dm³/h (7cu.feet).

2.6.3 The Exhaust (Dust Extraction) Connections.

The size of the connections are given on the Foundation and Dust Extraction Plan.

The part of the air pipe fitted to the Dust Hood should be flexible and detachable. The length of the flexible part is dependent on the way the pipe is used and on the adjustment required on the work spindle. As a guide one can employ a flexible pipe one metre long for the lower and fixed spindles and of 2 metres for the upper, left and canting spindles.

The flow of air to be at 25 - 30 metres per second.

THE VOLUME OF AIR REQUIRED.

For a Horizontal Spindle 17 - 20 metres³/min. (600 - 700cu.ft/min.)

For a Universal Spindle 17 - 20 metres³/min. (600 - 700cu.ft/min.)

For a Vertical Spindle 17 - 20 metres³/min. (600 - 700cu.ft/min.)

The Total Volume of air required for the Dust Extraction is directly related to the total number of spindles.

2.7 The Schematic Diagrams for Electrics, Pneumatics.

The electricians wiring diagram and the schematic diagram will be found in the electrical control cubicle of the machine.

2.8 When using the machine without a sound insulated booth - use ear muffs.

If required we can give you information on insulated sound booths and will also undertake to give you the Name and Address of a Supplier.

3.0 Placing the Machine in Service.

3.1 Service Instructions.

The "GA" is a high output automatic moulder of modular construction. It is equipped with a continuous feed works. The arrangement and the number of spindles are specified during manufacture.

These service instructions cover all the possible arrangements of the "GA" rendering it unnecessary to provide special instructions for a specific machine.

www.DaltonsWadkin.com

3.1.1 Structure of the Surfacer

The surfacer table and the fence guide are mounted on the framework of the surfacer. Both can be quickly adjusted by hand to accommodate the timber.

The maximum adjustment is 10mm.

To adjust the height of the surfacer table (1) first, unclamp the table by turning handle (2) in an anti-clockwise direction. Set the height required to a direct reading on the graduated scale (3) by moving handle (2) either to the left OR to the right. Re-clamp the table (1) by turning handle (2) in a clockwise direction.

The fence (4) is adjusted with handle (5) reading directly from the graduated scale (6) - clamping is carried out by handle (6a).

The adjustable guard (7) must be set to within 5mm. from the cutter-block. Slacken star handwheel (8), set guard and re-tighten handwheel.

The surface table and the fence are fitted with eccentric bolts. If for example after a period of prolonged operation the alignment of the table and the guide requires altering, it is possible to re-adjust the surfacer table OR the fence guide. Re-adjustment may also be necessary if the nature of the work demands a very precise finish.

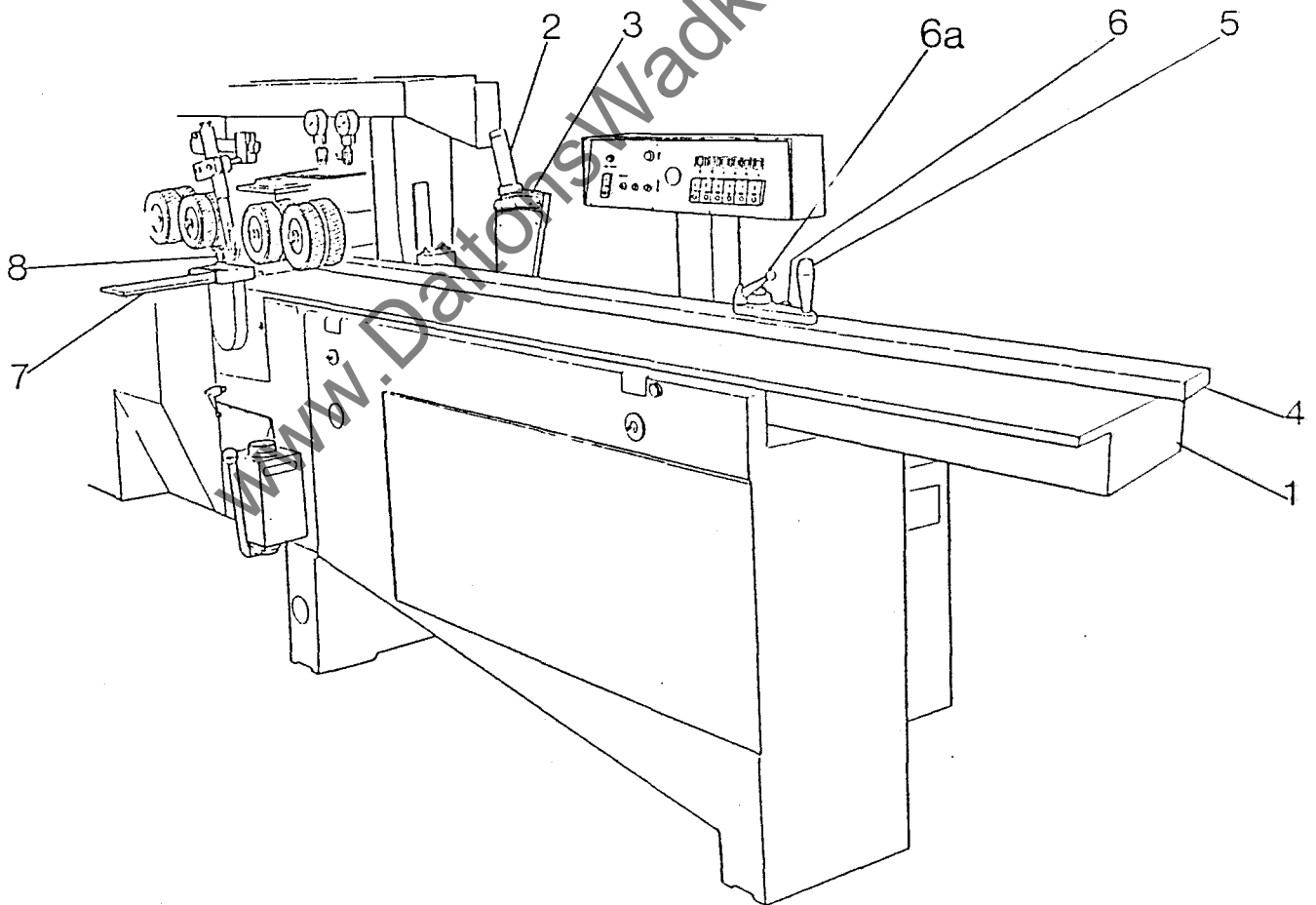

SURFACER TABLE AND INFEED FENCE GUIDE

3.1.2. Short Infeed Table.

A Short infeed table can be supplied instead of the Surfacer Table.

The procedure for accommodating the workpiece is made as follows:-

The adjustment of table (72a) is made by ratchet spanner (73) in conjunction with the calibrated scale (74) and locking lever (75). Locate the bedplate (72) approximately 5mm. from the cutterblock. To adjust the bedplate unfasten bolts (76), ascertain that the bedplate is free from dirt OR any other foreign matter, set bedplate then re-tighten.

The fence (77) is adjusted by hand lever (78).

The adjustment of the fence before the fence side vertical head is as described in paragraph.....3.1.1.

NOTE: ON MACHINES WITH GEAR DRIVEN FEEDROLLS THE SHORT INFEEED TABLE CAN BE SUPPLIED WITH A DRIVEN FLOATING BEDROLL TO GIVE CONSTANT FEED.

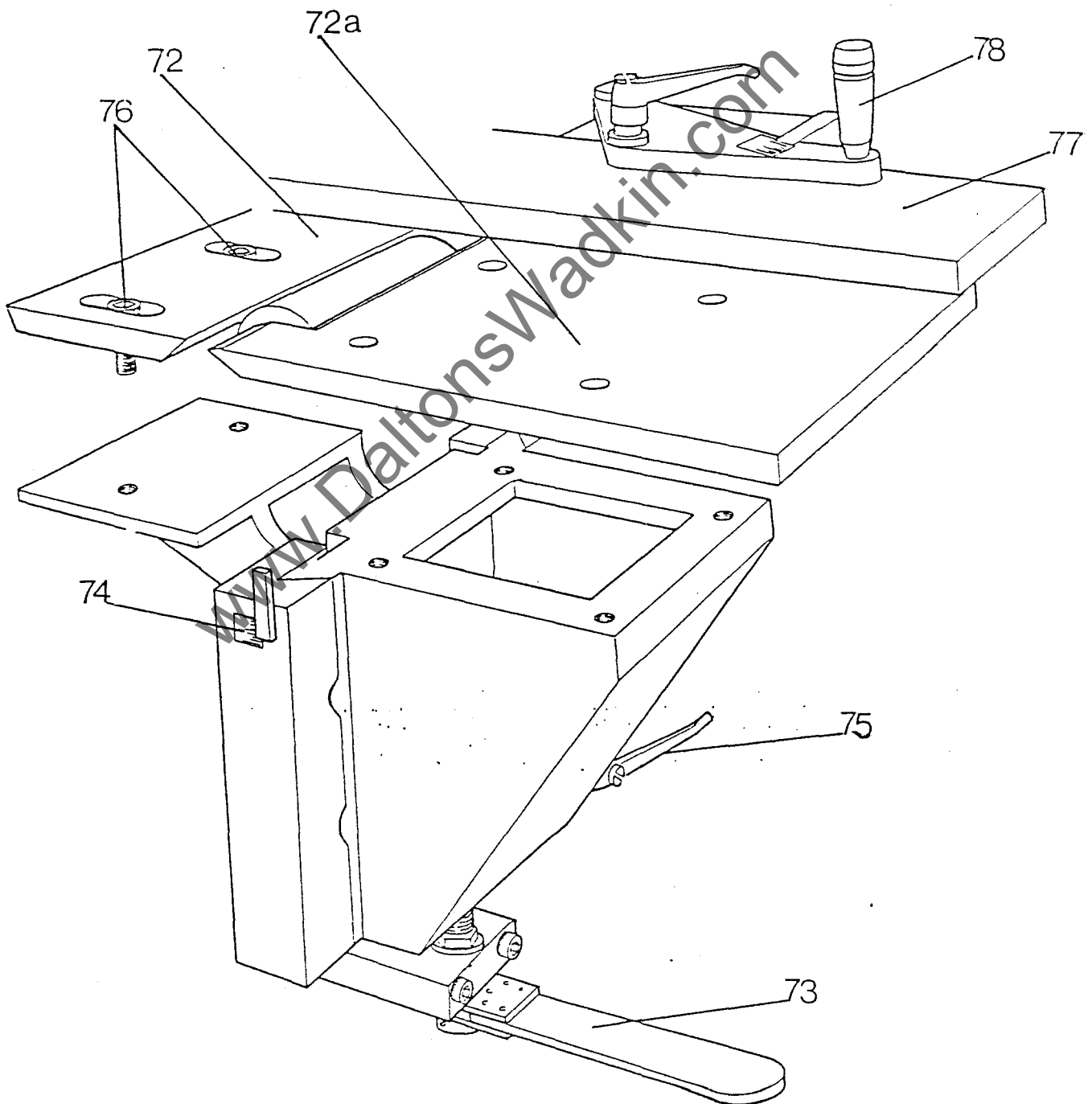

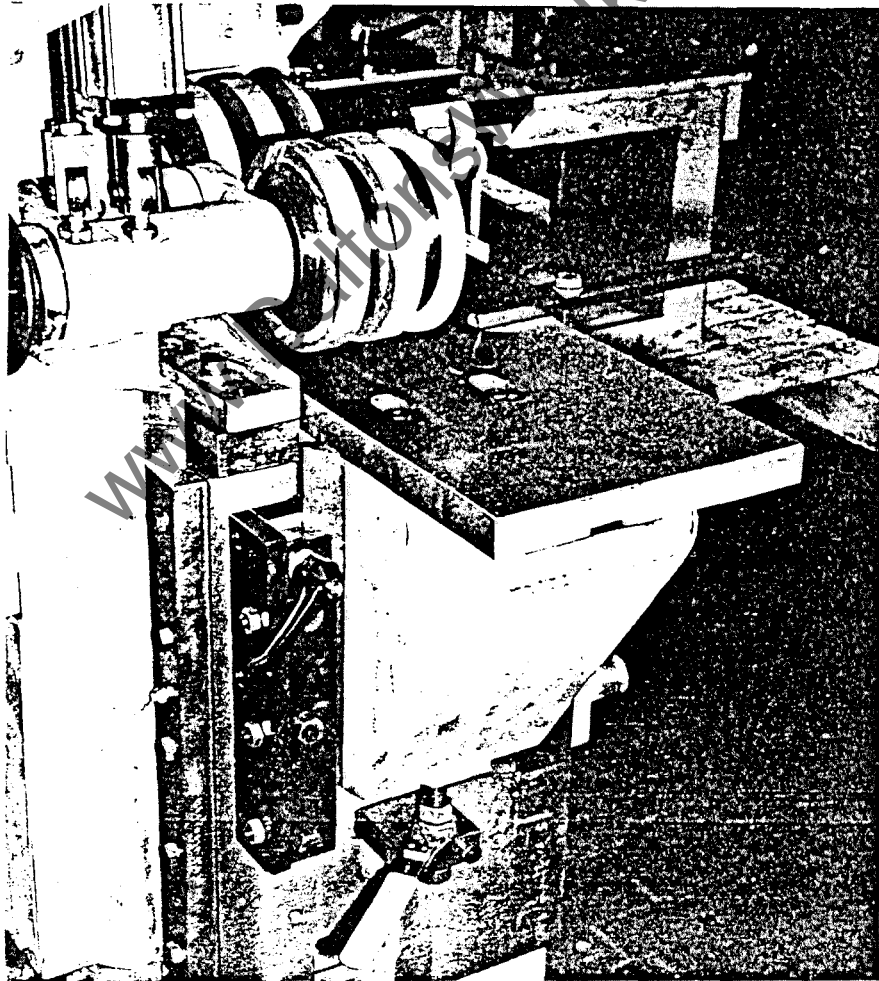
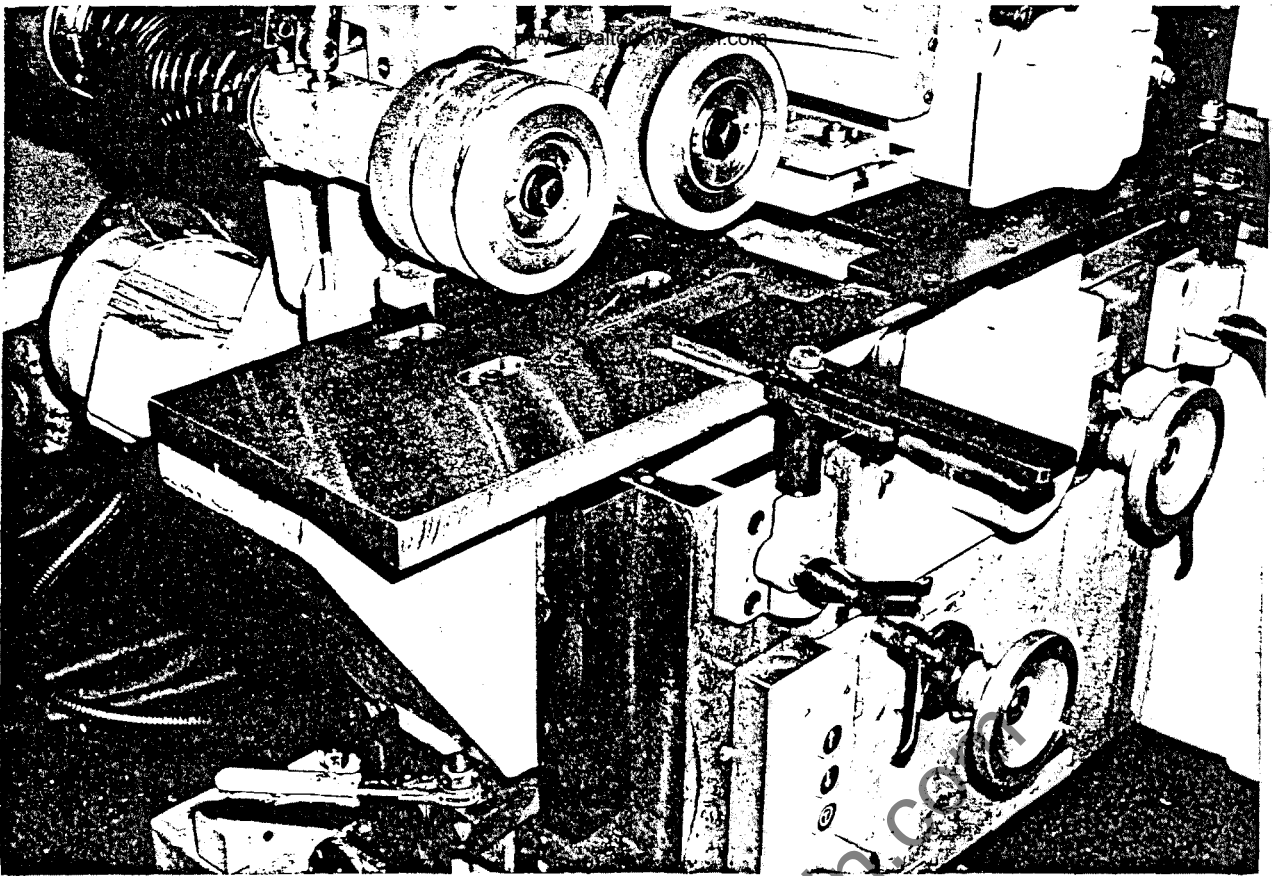

January, 1985

OUTFEED RISE AND FALL TABLE
(WHERE FITTED)

page 12a

3.1.3 Surfacers (First Bottom Horizontal Head).

The Surfacers spindle will accept a 125mm. diameter cutterblock. There is only vertical adjustment of the surfacer. For adjusting the spindle (1) vertically - unfasten the locking lever (9). To raise turn the handwheel (10) anti-clockwise to lower turn the handwheel (10) clockwise. After adjusting re-fasten the locking lever (9). Maximum obtainable cut 10mm.

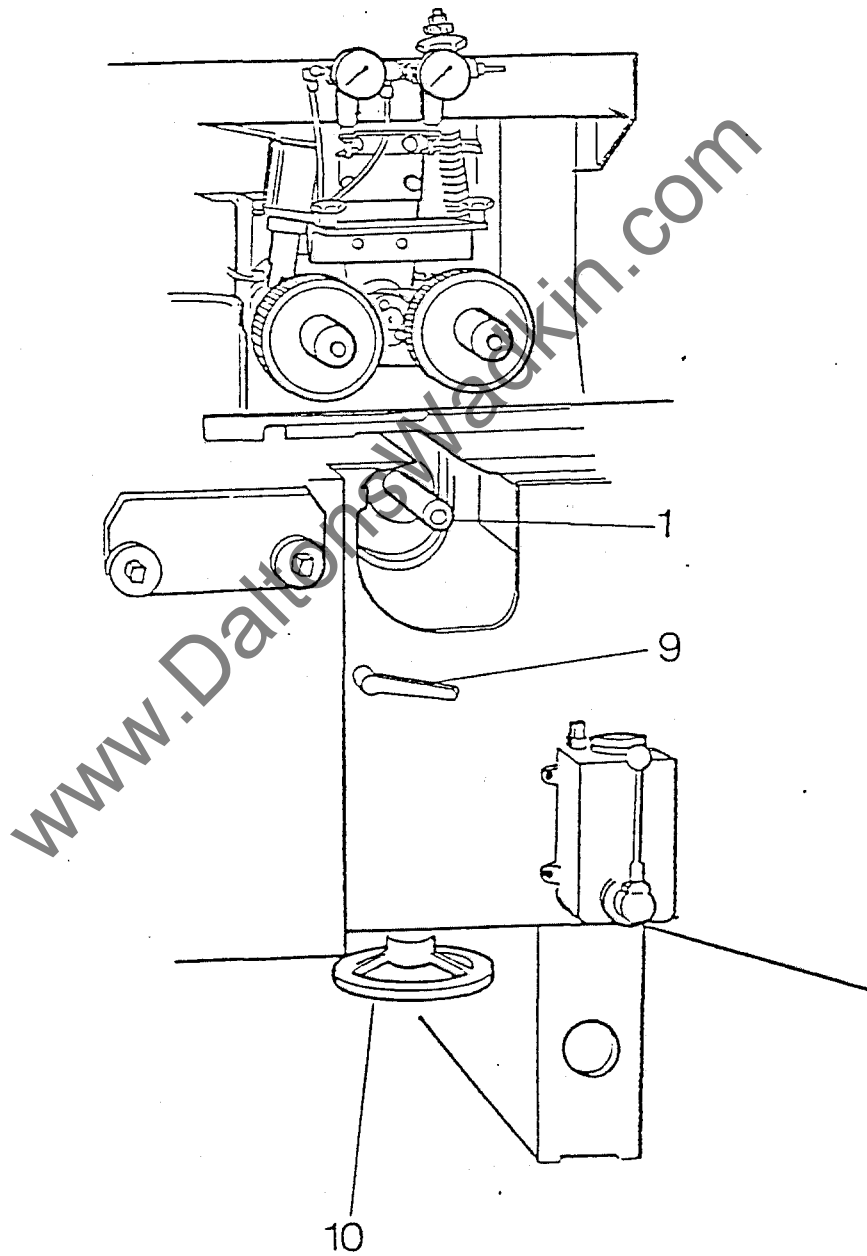

3.1.4 The Fence Side Vertical Spindles

The First Fence Side head has a cutting circle of 100mm. to 180mm. the maximum cutting circle of the Second Fence Side Head is 190mm.

The spindles can be adjusted vertically and laterally. The spindles can be lowered 40mm. below the table. The total lateral adjustment behind the fence line is 65mm. The lateral adjustment can be set from a dial graduated in increments of 1/10mm.

To adjust the spindles (2) and (4) vertically - unfasten the locking handles (11) and (12), having first unlocked handles (11a) and (12a). To raise the spindles (2) and (4). Place the crank handle on the squares (13) and (14) and turn clockwise. To lower turn anti-clockwise. After adjusting re-fasten the locking handles (11) and (12) then handles (11a) and (12a).

To adjust the spindles (2) and (4) laterally unfasten the locking handles (11a) and (12a). Place the crank handle on squares (15) and (16) and move the spindles forward by turning clockwise OR to move back by turning anti-clockwise. After making the adjustment re-fasten the locking handles (11a) and (12a).

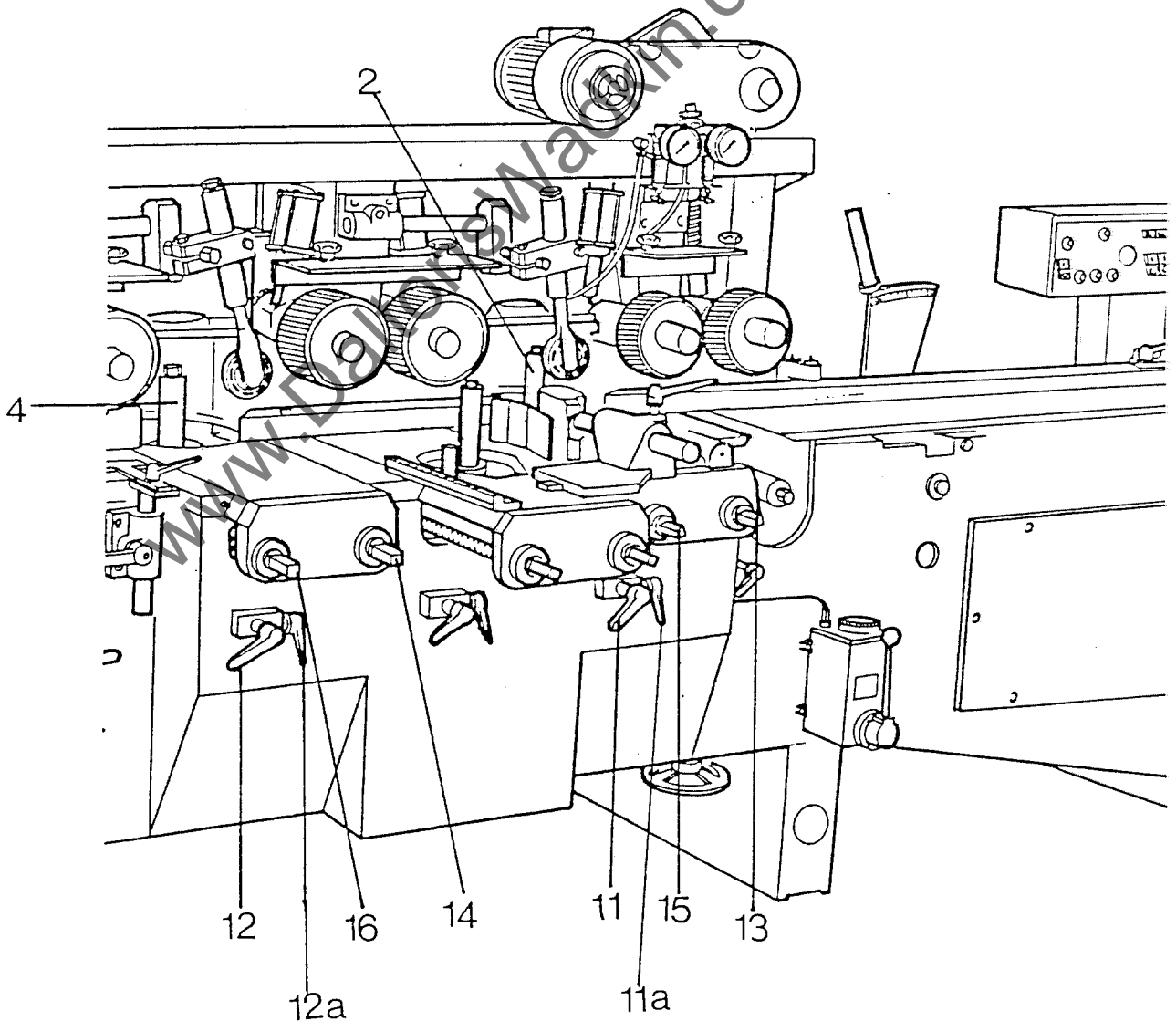

3.1.4 The Fence Side Vertical Spindles.....contd

Before mounting the cutterblocks of the Fence Side Heads (2) and (4). Adjust the fence (17) to suit the workpiece. Slacken the screws (18) with a 10mm. hexagon key.

Adjust the fence by turning the eccentric bolt (19) to the left to remove the least amount of timber OR increase cut to a maximum of 2mm. by turning to the right. After adjusting the fence (17) tighten the screws (18).

The adjustable nose pieces (20) of the fence (17) must be set about 5mm. from the cutterblock. To adjust the nose pieces (20) unscrew the hexagon bolts (21). Move the nose pieces then tighten the bolts.

When adjusting the nose pieces make sure that these and the fence supports are free from wood shavings.

The correct alignment of the fences has a great influence on the finish and quality of the work.

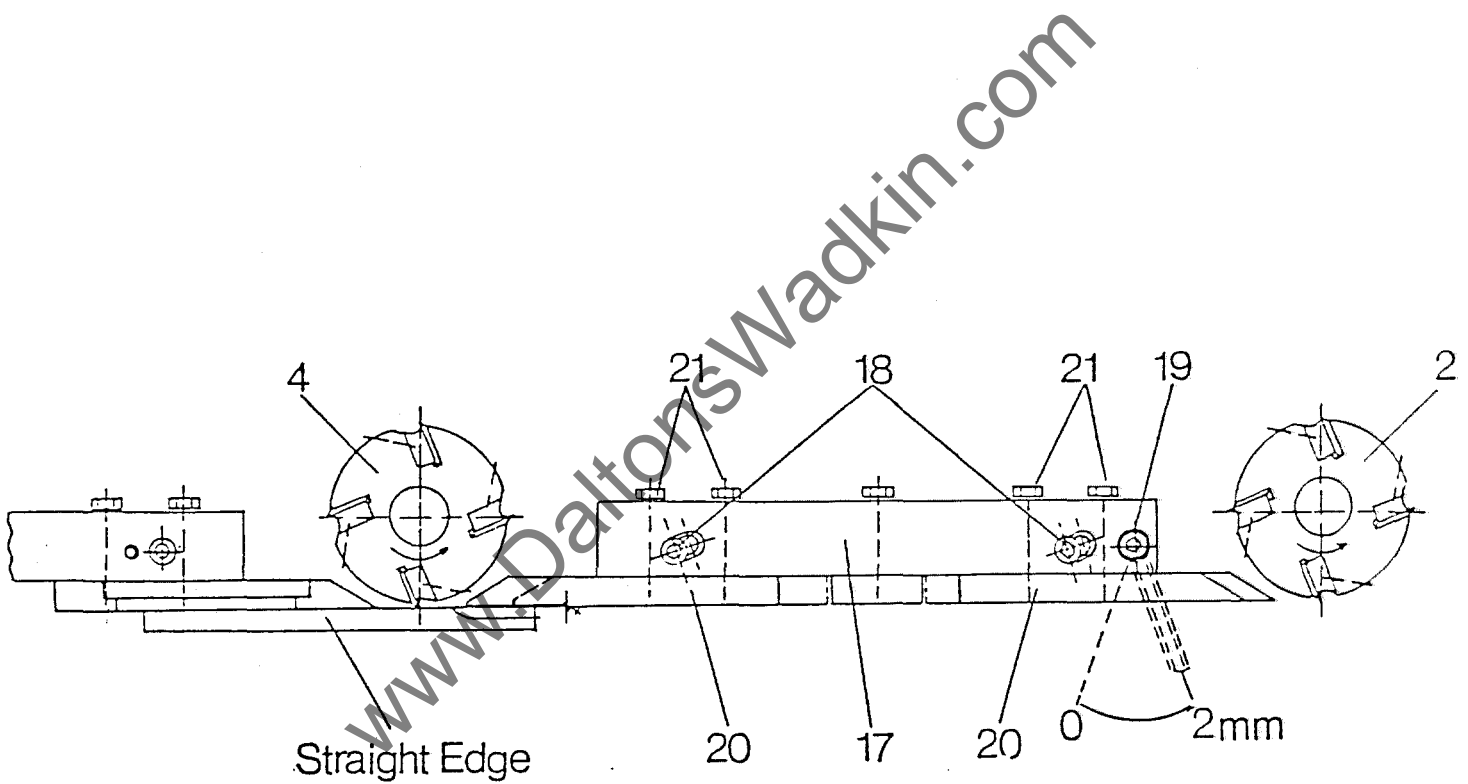

3.1.5 The Near Side Vertical Head.

The Near Side vertical head has a cutting circle of 100mm. to 180mm. the spindle can be adjusted vertically and laterally. The cutter-block can be lowered 40mm. below the table. With a 125mm. dia. cutterblock fitted the lateral adjustment will accept a workpiece of 0 - 170mm. wide. on Model (170) and 0 - 220mm. wide on Model (220).

The lateral adjustment can be set from a dial graduated in increments of 1/10mm. To adjust the spindle (3) vertically. Unfasten the locking handles (22), having first unlocked handle (22a). To raise the spindle (3) place the crank handle on square (23) and turn clockwise. To lower turn anti-clockwise. After adjusting re-fasten locking handles (22) and (22a).

To adjust the spindle (3) laterally. Unfasten the locking handle (22a). Place the crank handle on square (24) and move the spindle forward by turning clockwise OR to move back by turning anti-clockwise. After making the adjustment re-fasten the locking handle (22a).

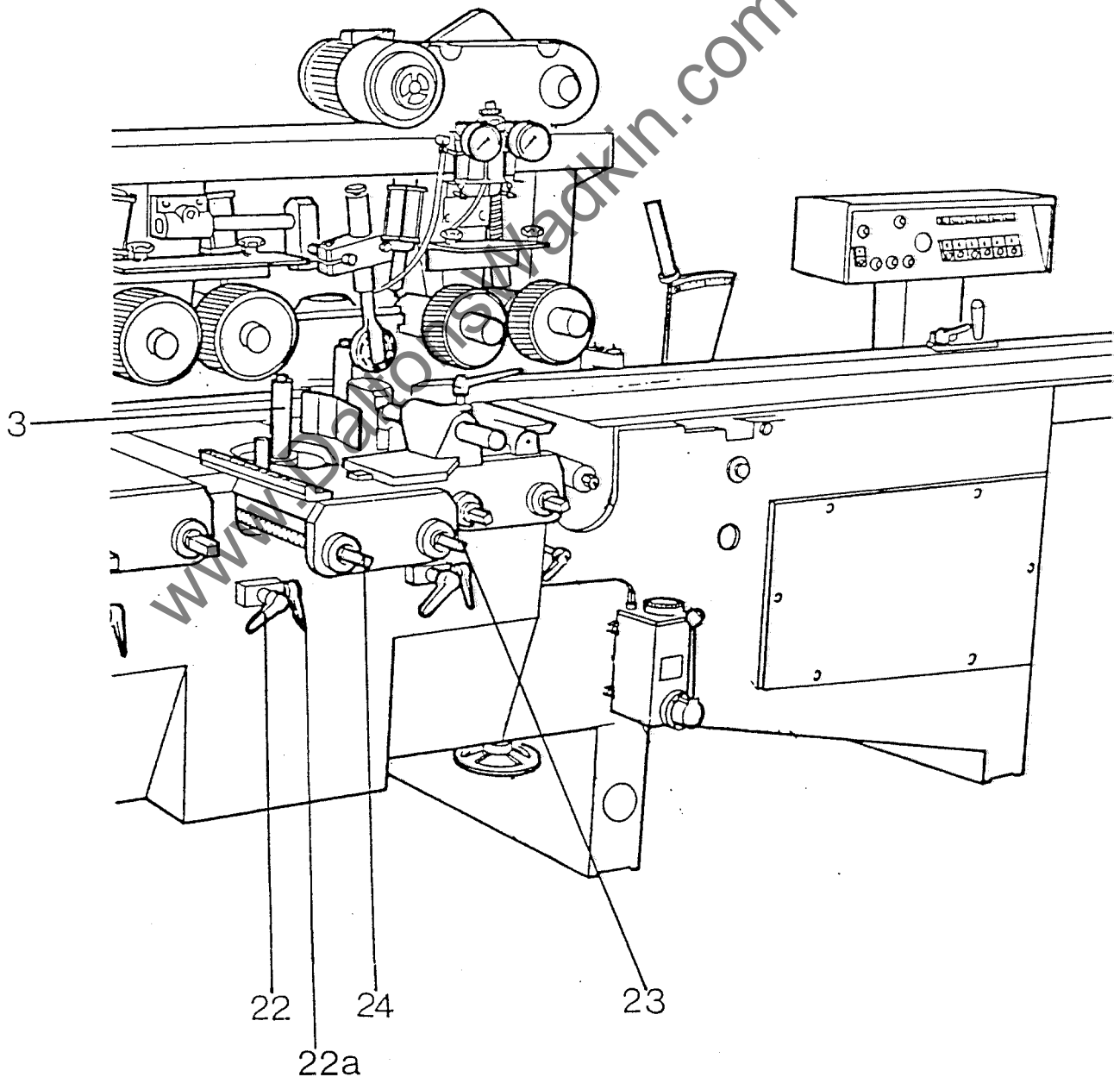

3.1.5 The Near Side Vertical Head.....contd.

Adjusting the Chipbreaker.

Remove the cover of the Dust Hood. Unfasten the locking handle (25). Adjust the chipbreaker (26) so that it clears the smallest cutting circle by about 2mm. Re-fasten the locking handle (25). Then unscrew the bolts (27) and adjust the chipbreaker (26) to suit the cutterblock diameter so that it clears the cutterblock by 20mm.

Re-tighten the bolts (27).

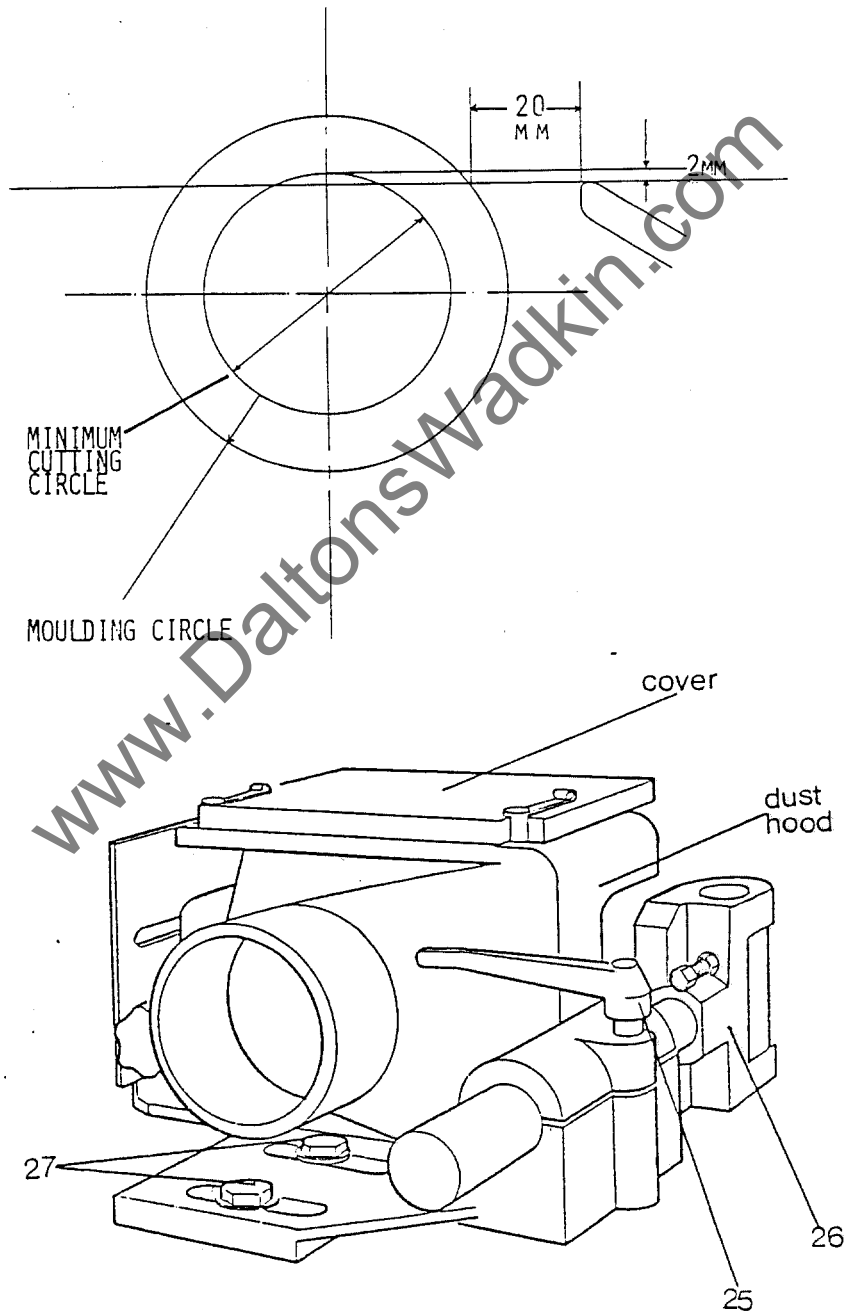

POSITION OF AIR
PRESSURE GAUGE
FOR CYLINDER.

POSITION OF "GREEN"
INDICATOR LIGHT

INFEED GATE

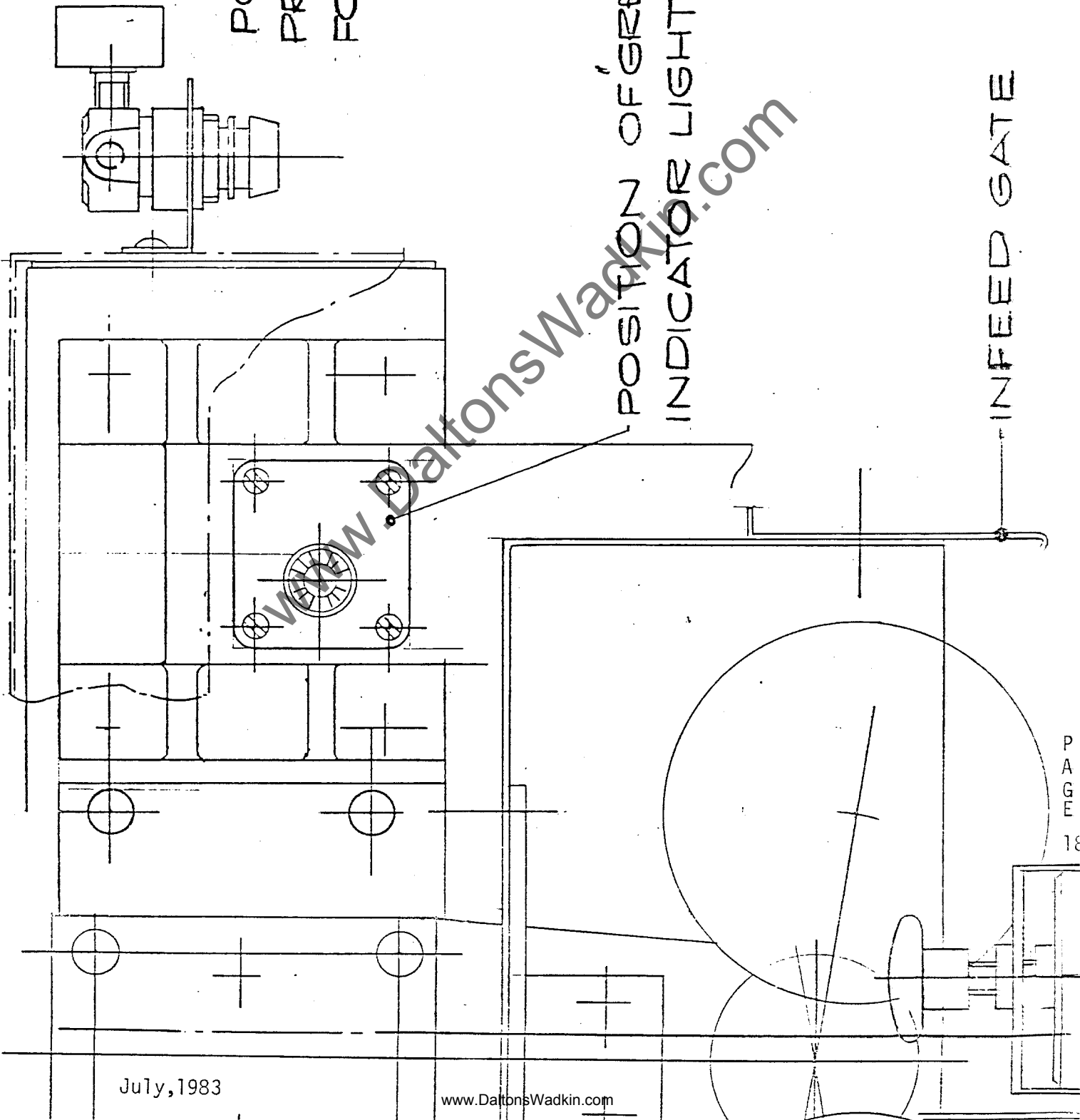

NEAR SIDE HEAD WITH RANDOM WIDTH SELECTION (WHERE FITTED)

Maximum feed speed	15m/min.
Maximum cut on any piece	15mm.
Minimum length	400mm.
Minimum width	50mm. (finished)
Maximum width	220mm. (finished)
Maximum variation in timber width	100mm.
Maximum height	100mm. (finished)

This device will accept any width of timber within the above sizes fed in any order.

An automatic illuminated lamp is provided to indicate when timber may be fed into the machine.

On no account should an attempt be made to feed timber whilst the lamp is not lit.

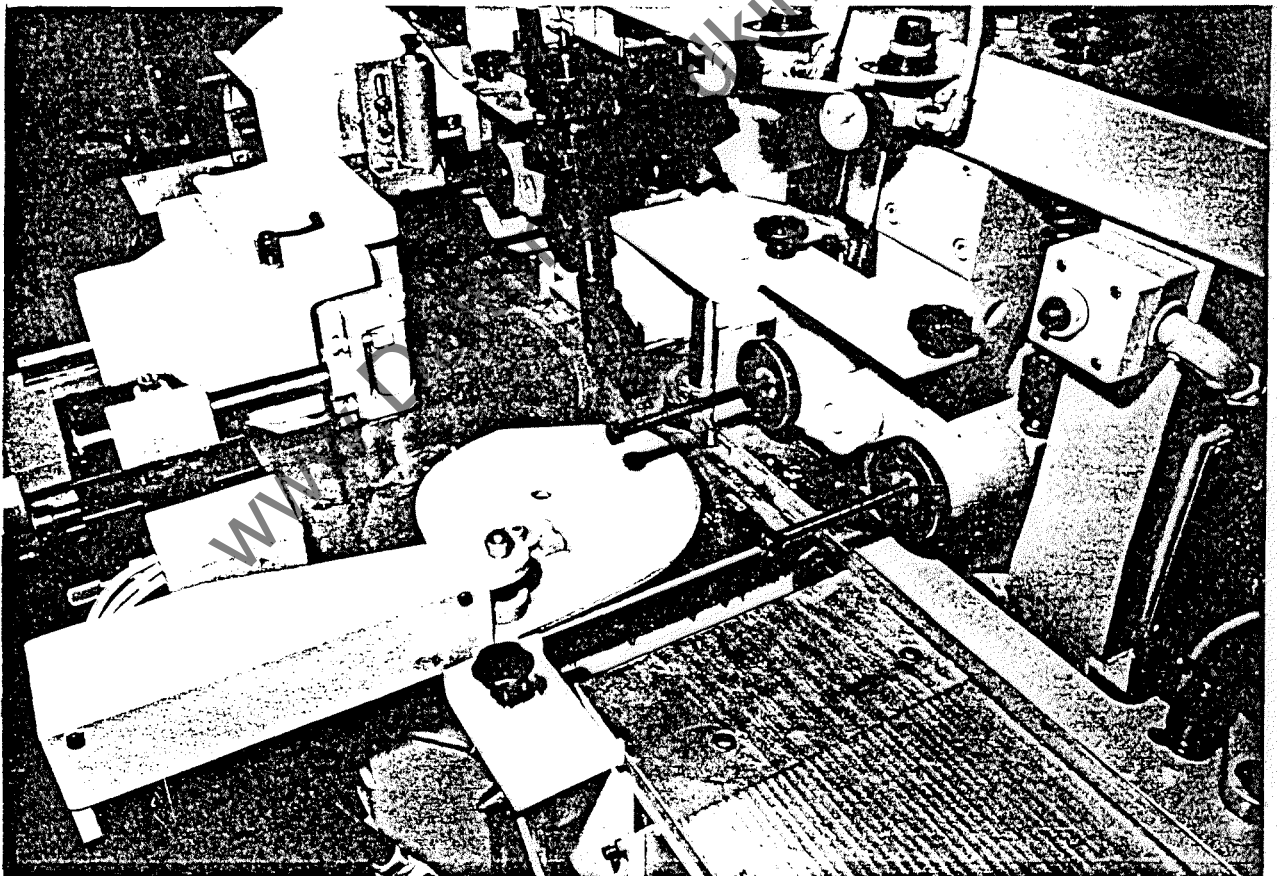

DIAL - A - SIZE ELECTRONIC POSITIONING - WHERE FITTED
TO THE NEAR SIDE HEAD AND TOP HEAD.

The powered traverse movement to the Near side head is by a "KEMO" geared motor.

The traverse movements of the heads are each connected to an 'encoder' which sends pulse signals to its respective "Elgo" digital read-out controller situated in the electrical control console.

The traverse of the heads re-acts to figures put into the "Elgo" controller which displays the cutter block position in relation to its datum face.

The datum face for the near side head is the fence and for the top head the bed-plate.

A switch is provided so that the head movements may be hand traversed OR power traversed.

Two manual setting devices are fitted on the rear face of each "Elgo" unit.

- 1) A coding switch which can be pre-set between 0.1 and 9.9mm. (Decimal digit is white on red, whole digit white on black).

This device is to compensate for traverse over-run due to the time delay thro' the electronic switching system.

(This will be set by "WADKIN" and would not normally need to be interfered with).

- 2) A coding switch which can be set between 1 and 99mm. (Both digits white on black). This device sets the length of a built-in over-run to eliminate the effects of backlash inherent in the traverse parts when moving away from datum.

This ensures that the displayed position is always determined when the traverse is moving in one direction only i.e. towards the datum face.

(This will also be set by "WADKIN" and would only need to be re-set if excessive backlash should develop).

METHOD OF OPERATION - TO SET DATUM

- A) Switch to hand operation. 
- B) Determine the distance between the cutterblock and either the fence OR bedplate by use of a known thickness setting block OR piece of timber - by hand winding the spindle up to the setting block.

Set this figure on the coding switches.

Press datum pushbutton (Blue).

These figures will now be displayed on the readout.

The datum figure is now set.

NOTE: These need only be re-set at machine switch-on OR if the cutterblocks are changed).

DIAL - A - SIZE ELECTRONIC POSITIONING CONTD

TO MOVE THE HEADS TO A PRE-DETERMINED POSITION

- C) Switch to "ELGO"
- D) Set coding switched to give the required position.
Press "START" push button.

Head will now move automatically to this position and the figures will be displayed on the read-out.

To move to a new position - repeat step (C) and (D).

NOTE: 1) THE FEED CAN ONLY BE INCHED IN THIS MODE.

NOTE: 2) TO HAND SET THE HEIGHT OF THE TOP HORIZONTAL SPINDLE INDEPENDENTLY OF THE BEAM DIS-ENGAGE CLUTCH (I.E. OPERATE CHANGE-OVER HAND LEVER (30)).

..... See paragraph 4 & 5 * Section 3.1.6 Page 22.

TO RUN THE MACHINE

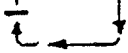
- E) Switch to automatic 
- F) The feed can now run continuously OR inched.

TOP HEAD
CODING SWITCHES

SIDE HEAD
CODING SWITCHES

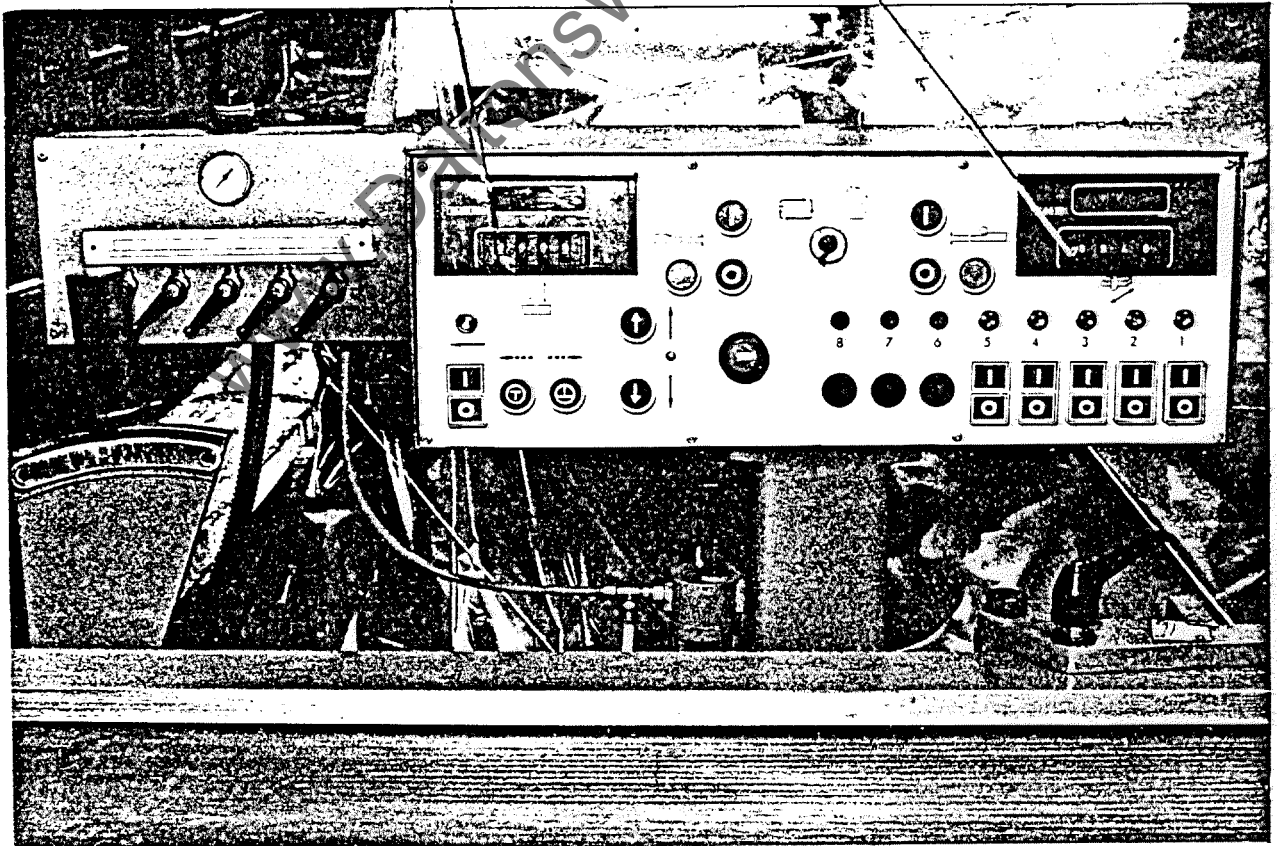

ELECTRONIC POSITIONING WITH PROGRAMMABLE MEMORY TO NEARSIDE AND TOP HEAD (WHERE FITTED)

The powered traverse movement to the Nearside Head is by a "KEMO" geared motor.

The traverse movements of the heads are each connected to an 'encoder' which sends pulse signals to its respective "ELGO" digital read-outs controller situated in the electrical control console.

The traverse of the heads re-acts to Figures put into the "ELGO" controller which displays the cutterblock position in relation to its datum face.

The datum face for the Nearside Head is the Fence and for the Top Head the Bedplate.

A switch is provided so that the head movements may be hand traversed OR power traversed.

NOTE: TO HAND SET THE HEIGHT OF THE TOP HORIZONTAL SPINDLE
INDEPENDENTLY OF THE BEAM DIS-ENGAGE CLUTCH (I.E.
OPERATE CHANGE-OVER HAND LEVER (30)).

..... See paragraph 4 & 5 * Section 3.1.6Page 22.

METHOD OF OPERATION TO SET DATUM

- A) Switch to hand operation.
- B) Determine the distance between the cutterblock and either the Fence OR Bedplate by use of a known thickness setting block OR piece of timber - by hand winding the spindle up to the setting block.

TO SET DATUM

Press N.R. then press 01, E1 will now appear in Register N.R. then press C.

Now enter known datum using key pad.

This figure will appear in the bottom register.

Then press datum button (Blue) the figures will now appear in top register (note figure X should always read 01 for the application of this machine).

Then press E. The datum is now set. The datum will need to be re-set when the cutterblocks are changed.

NOTE: FIRST DIGIT ENTERED WILL APPEAR TO RIGHT OF DECIMAL POINT.

For example to enter 101mm.

Press 1010 read-out will show 101.0.

To enter 96.7 press 967 and read-out will show 96.7.

The first programme will now appear in the bottom register. (These programmes will have been set by "WADKIN" during the machine test).

ELECTRONIC POSITIONING WITH PROGRAMMABLE MEMORY CONTD

FOR THE CUSTOMER TO SET THEIR OWN PROGRAMME PROCEED AS FOLLOWS:-

PARA

1 First press N.R. then C (N.R. digits will now read 00). Enter desired programme (for example 01) N.R. digits will now read 01 then press = then press C.

Then enter dimension required - then press X.

NOTE

'A' If Fig X does not read 01 then press C and enter 01.

EXAMPLE 1.

To set 250mm. from Fence OR Bedplate in programme NO:1. - press N.R. then C then enter 01 then press = then press C then 2500 then press X(See Note 'A') the dimension 250.0 will now appear in bottom register and figures in N.R. will read the programme number 01.

TO CONTINUE TO ENTER FURTHER PROGRAMMES REPEAT ABOVE FUNCTIONS COMMENCING WITH PARA 1.

EXAMPLE 2.

To enter programme No: 02. at dimension 137.5 Press N.R. then C then enter 02 then press = then enter dimension 1375 then press X (See Note 'A'). The dimension 137.5 will now appear in the bottom register and N.R. will read 02.

Continue in this manner up to and including programme 13.

When the entry of programme 13 is completed i.e. after X is pressed press E. the bottom register will now show programme 01.

To check complete programme depress T and the next programme will be displayed on the bottom register - repeat for each successive programme.

PARA

2 TO IMPLEMENT CHOSEN PROGRAMME.

SELECT AUTO (MAIN PANEL)

Press T in succession until the selected programme appears in the N.R. register. Then press "START" button (Green) - Main Panel. The head will move automatically to the chosen dimension, the chosen dimension will now appear in the top register. The following programme will be displayed in the bottom register.

Should it be necessary to stop the head moving whilst the automatic positioning is taking place, depress "STOP" button (Red) - Both Unit and Main Panel.

NOTE: THE HEAD WILL STOP IMMEDIATELY BUT THE BOTTOM REGISTER WILL SHOW THE NEXT PROGRAMME.

To re gain the interrupted programme See Para 2.

ELECTRONIC POSITIONING WITH PROGRAMMABLE MEMORY CONTD

TO CHANGE A GIVEN PROGRAMME

Depress T as above until selected programme number appears. Then repeat the normal programming procedure See Para 1. When the change is completed press N.R. and 02 then E.

THE PROGRAMMING SEQUENCE FOR PROGRAMMES (1 - 13) IS SHOWN IN A SIMPLIFIED FORM AS UNDER :-

- 1) Press N.R.
- 2) Press C.
- 3) Enter programme No:
- 4) Press =
- 5) Press C.
- 6) Enter dimension
- 7) Press X (if X reads 01; ignore steps 8 and 9).
- 8) Press C.
- 9) Enter 01.

To continue programming - recommence at No: 1.

- 10) To end programme - press E.

Programmes 14 and 15 are purely incremental and would not normally be used on Woodworking Machinery.

TO CHANGE A GIVEN PROGRAMME; SIMPLIFIED FORM.

- 1) Press N.R.
- 2) Press C.
- 3) Enter programme No:
- 4) Press =
- 5) Press C.
- 6) Enter dimension
- 7) Press X (if X reads 01; ignore steps 8 and 9).
- 8) Press C.
- 9) Enter 01.
- 10) Press N.R.
- 11) Press 02.
- 12) Press E.

WARNING: DO NOT USE POSITIONING SYSTEM WHEN TIMBER IS IN THE MACHINE.
WHEN THE MACHINE IS SWITCHED ON OR A CUTTERBLOCK CHANGED THE DATUM FIGURE MUST BE CHECKED.

With this unit it is possible to bypass the programme and set in any desired value. On activating start, the machine runs to this position. This selection and return to programme is available at all times.

3.1 To select

Press NR (cursor point illuminates in Address Display)

Press E (cursor point extinguishes)

Press 0 (EO appears in Address Display)

3.2 The desired position can now be given directly from the Numerical Keypad.

Press C

Key in desired position.

(The controller now operates like a "Dial-a-Size" and could be left in this mode if desired).

3.3 To return to programme mode, two options are available.

3.3.1 Press PROG (EO is extinguished)

The first address in the preset programme is selected.

3.3.2 Press E (EO is extinguished)

The address that had previously been indicated, before selection to "Single Position", will once more be indicated.

3.1.6 Top Horizontal Spindle www.DaltonsWadkin.com

The Top Horizontal head is arranged for a cutting circle of 100 - 180mm. The spindle can be adjusted vertically and laterally. With a 125mm. diameter cutterblock fitted the adjustment will allow for a workpiece from 0 to 130mm. high.

The lateral adjustment is 50mm.

The vertical adjustment is provided with a calibrated dial graduated in increments of 1/10mm. this is located behind handwheel (29).

* To adjust the spindle (5) vertically. Unfasten the slide locking lever (28) 1/4 to 1/2 a turn (to unlock top head slide and to close rear limit switch (35)). To raise the spindle turn the handwheel (29) anti-clockwise and to lower turn clockwise.

* To use the automatic vertical adjustment, engage the changeover hand lever (30). Keep the hand on the changeover lever until the clutch is engaged. If the clutch does not readily engage operate the handwheel (29) by slightly turning to the right OR left until engagement is made. To raise OR lower top horizontal spindle press appropriate button at (31). The vertical adjustment of the feed only works in conjunction with the top horizontal head. After positioning the spindle lift the changeover lever (30) and thus disengage the automatic vertical adjustment.

Finally adjust with the handwheel (29). Re-fasten slide locking lever (28).

To adjust the spindle (5) laterally. Unfasten the locking lever (32) at the rear of the machine.

To move the spindle (5) forward turn the handwheel (33) clockwise OR to move back turn the handwheel (33) anti-clockwise. The adjustment is provided with a calibrated dial graduated in 1/10mm. After adjusting re-fasten the locking lever (32).

The bedplate under the top horizontal head can be replaced by one of wood so that a saw OR saws can be used if required.

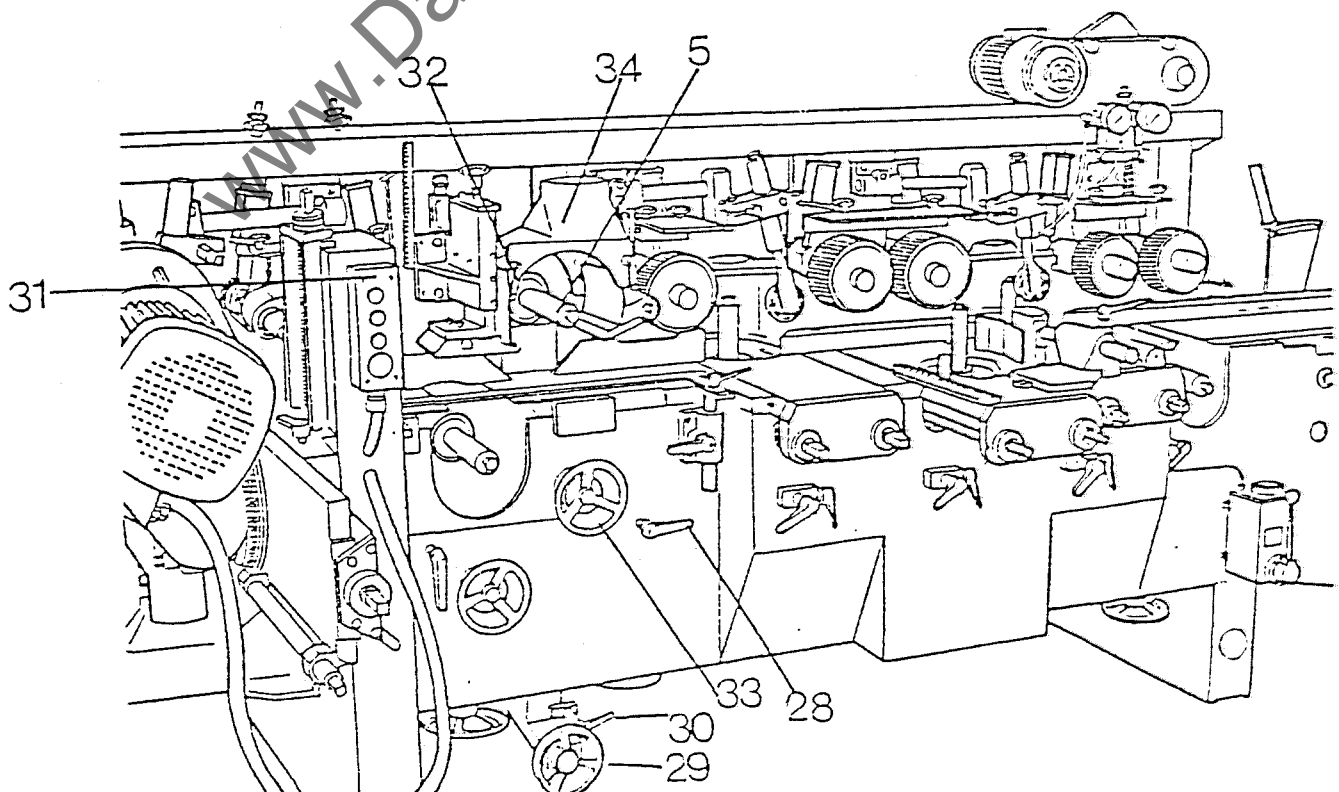

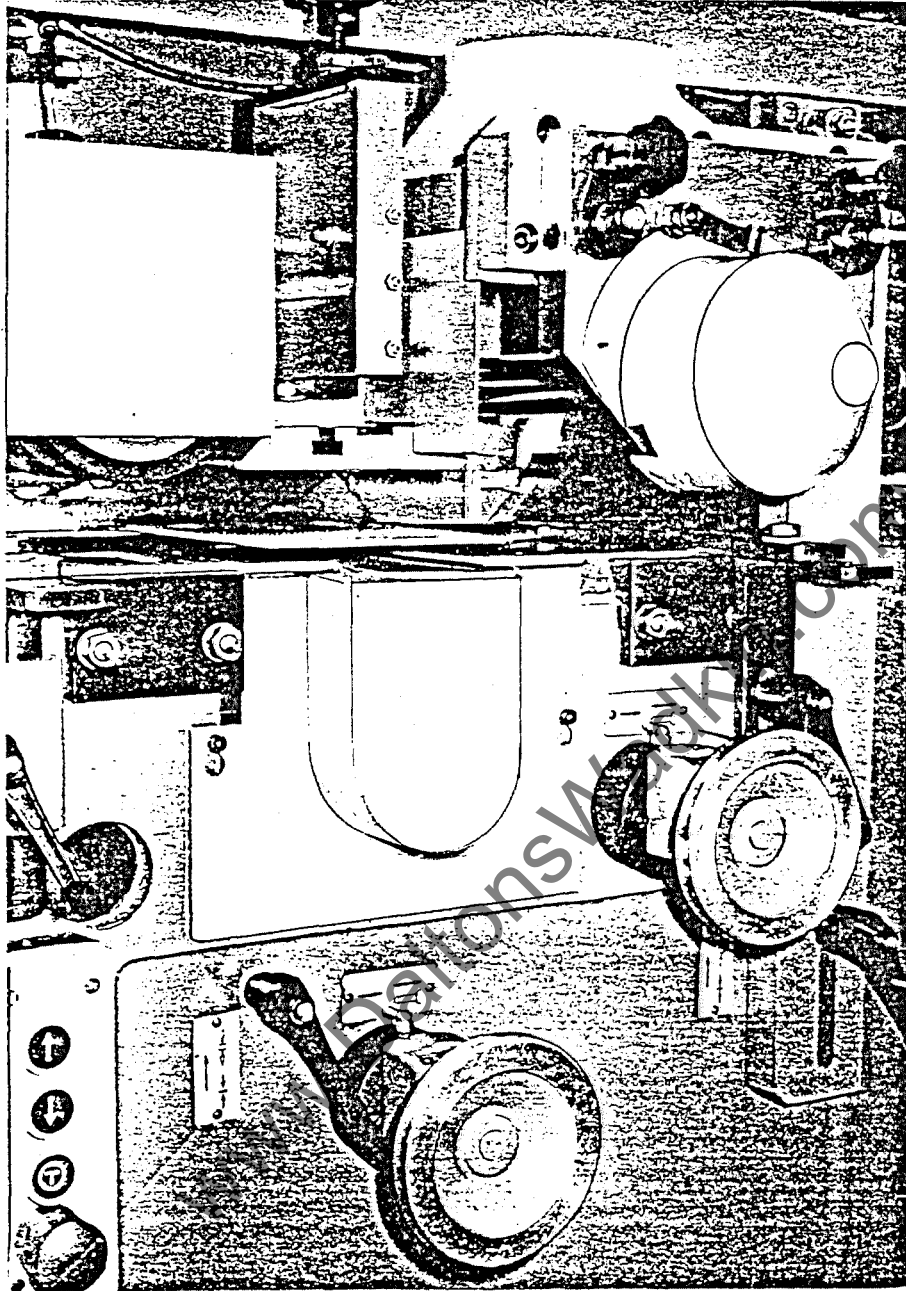

28

WHEN OUTBOARD BEARING FITTED TO TOP HEAD

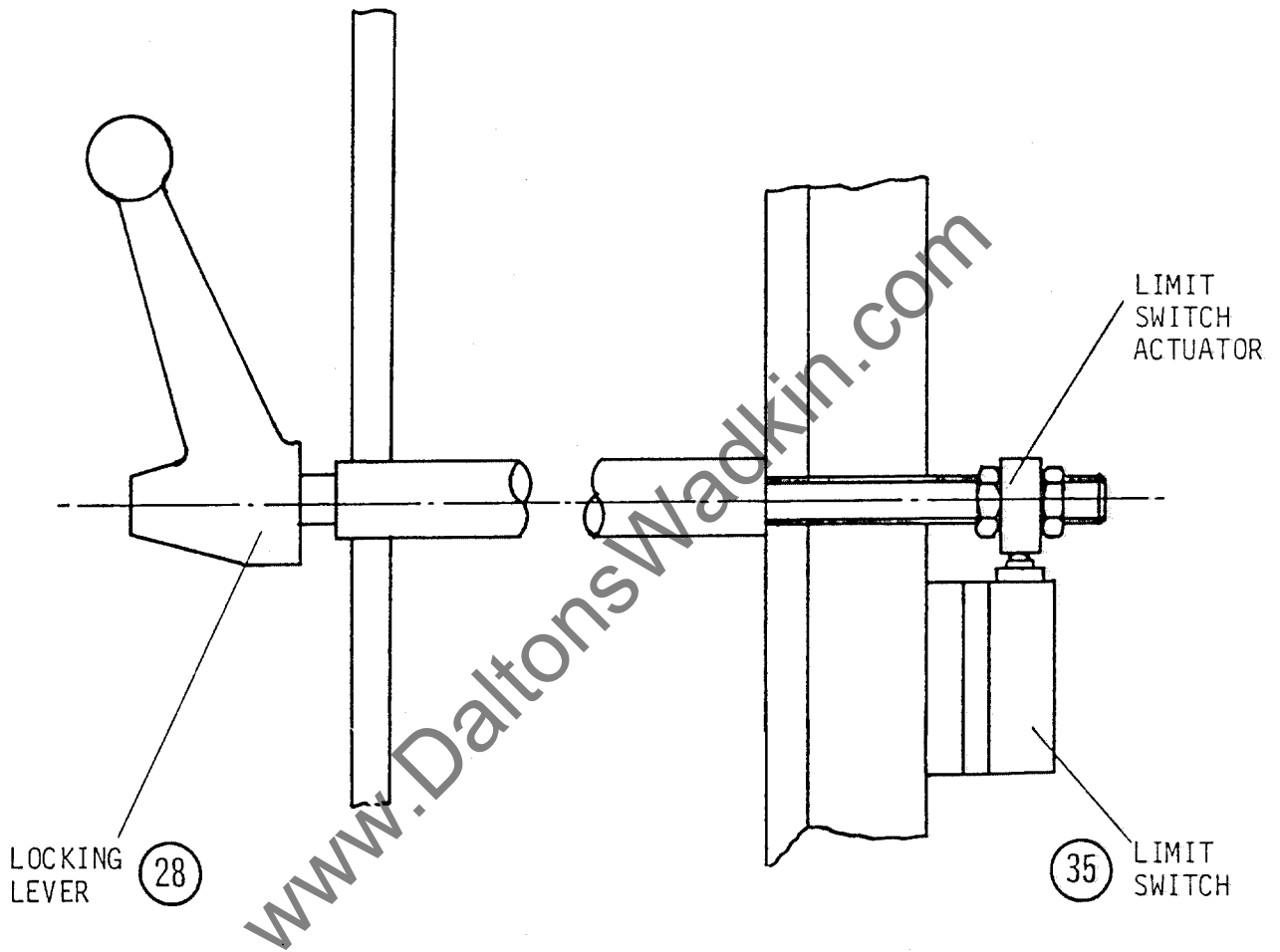

ARRANGEMENT OF LIMIT SWITCH FOR TOP HEAD SLIDE LOCKS

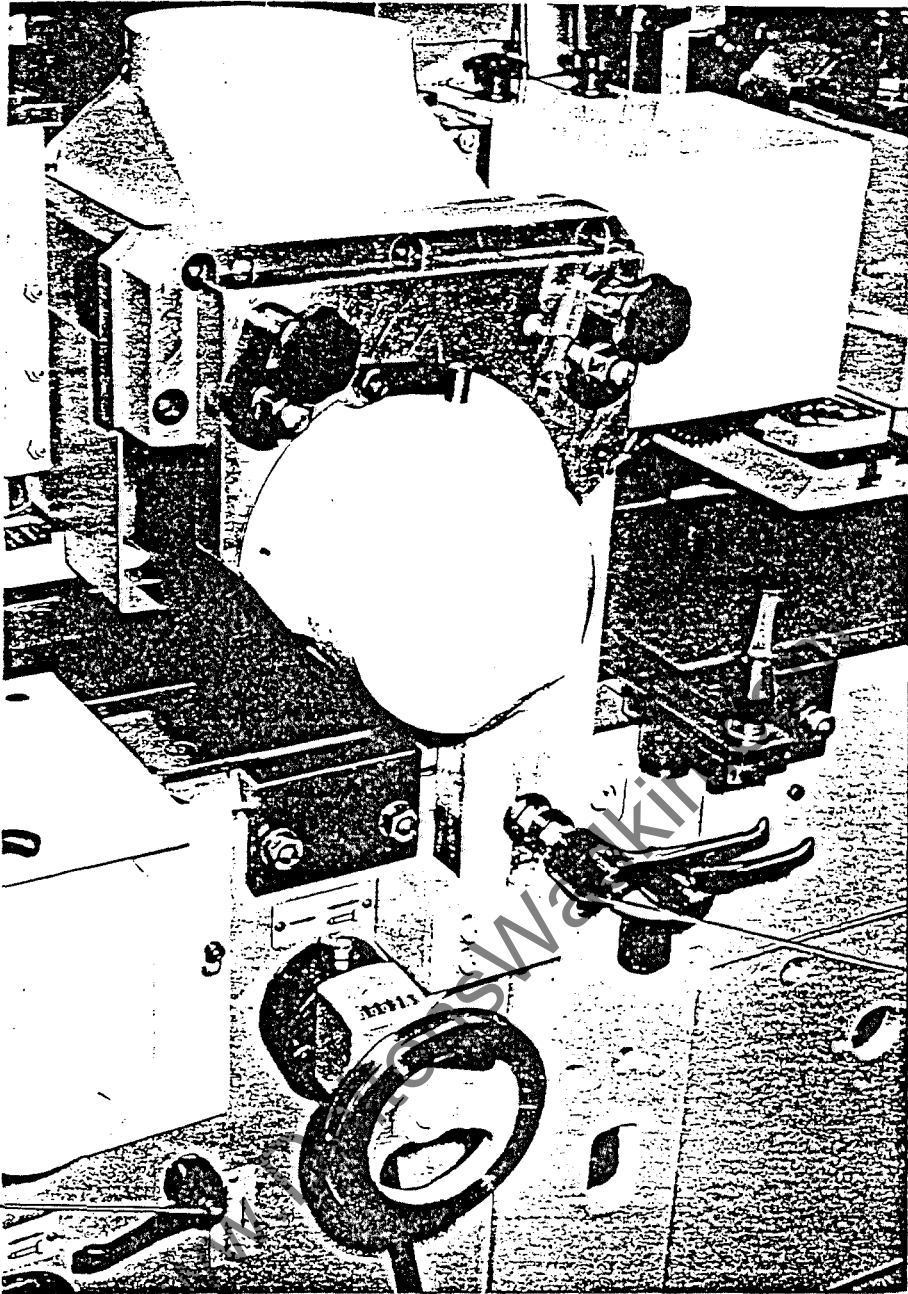

28
LOCKING
LEVER

28
LOCKING
LEVER

WHEN OUTBOARD BEARING FITTED TO ADDITIONAL TOP HEAD

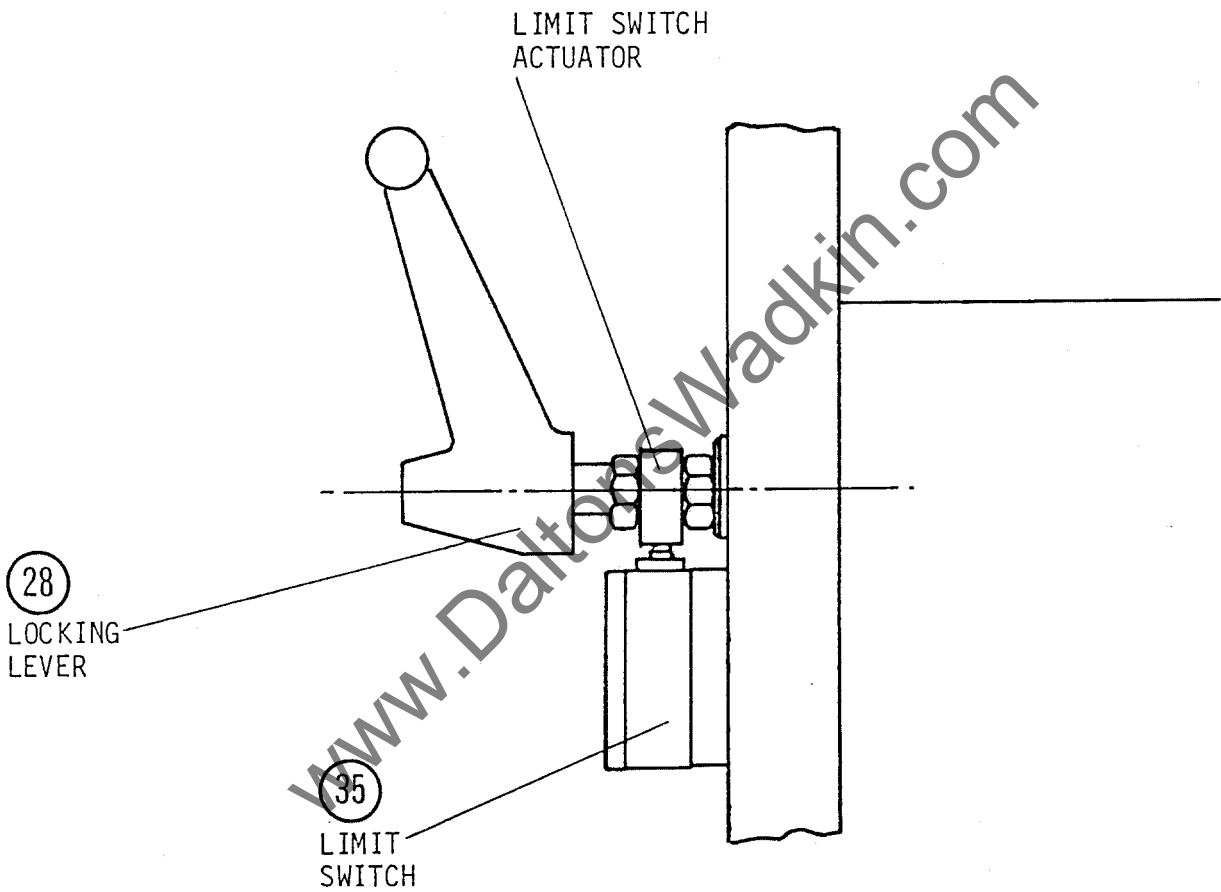

ARRANGEMENT OF LIMIT SWITCH FOR OUTBOARD BEARING LOCK ON ADDITIONAL HEADS ONLY

3.1.6 Top Horizontal Spindle.....contd.

To adjust the chipbreaker (35) for height. Unscrew the screws (36). Adjust the chipbreaker so that the lower edge is about 5mm. lower than the smallest cutting circles. Re-tighten the screws.

To adjust chipbreaker to suit a different cutting circle - open the cover. Unfasten the nut (37). Withdraw the chipbreaker and exchange it with an alternative chipbreaker to suit the cutting circle. Re-fasten the nut (37). Raise the chipbreaker to the maximum and check that the cutterblock is free to rotate. Adjust the tension of the chipbreaker by bolt (38).

Adjust the outfeed pressure shoe (39) with star shaped handle (41) so that it is located 1mm. higher than the smallest cutting circle. Unfasten the screws (40) and place the outfeed pressure about 5mm. from the cutterblock. Re-tighten screws (40). Adjust the pressure on the screw with hexagon nuts (42).

Adjust the pressure shoe (39) with star shaped handle (41) after inserting the workpiece.

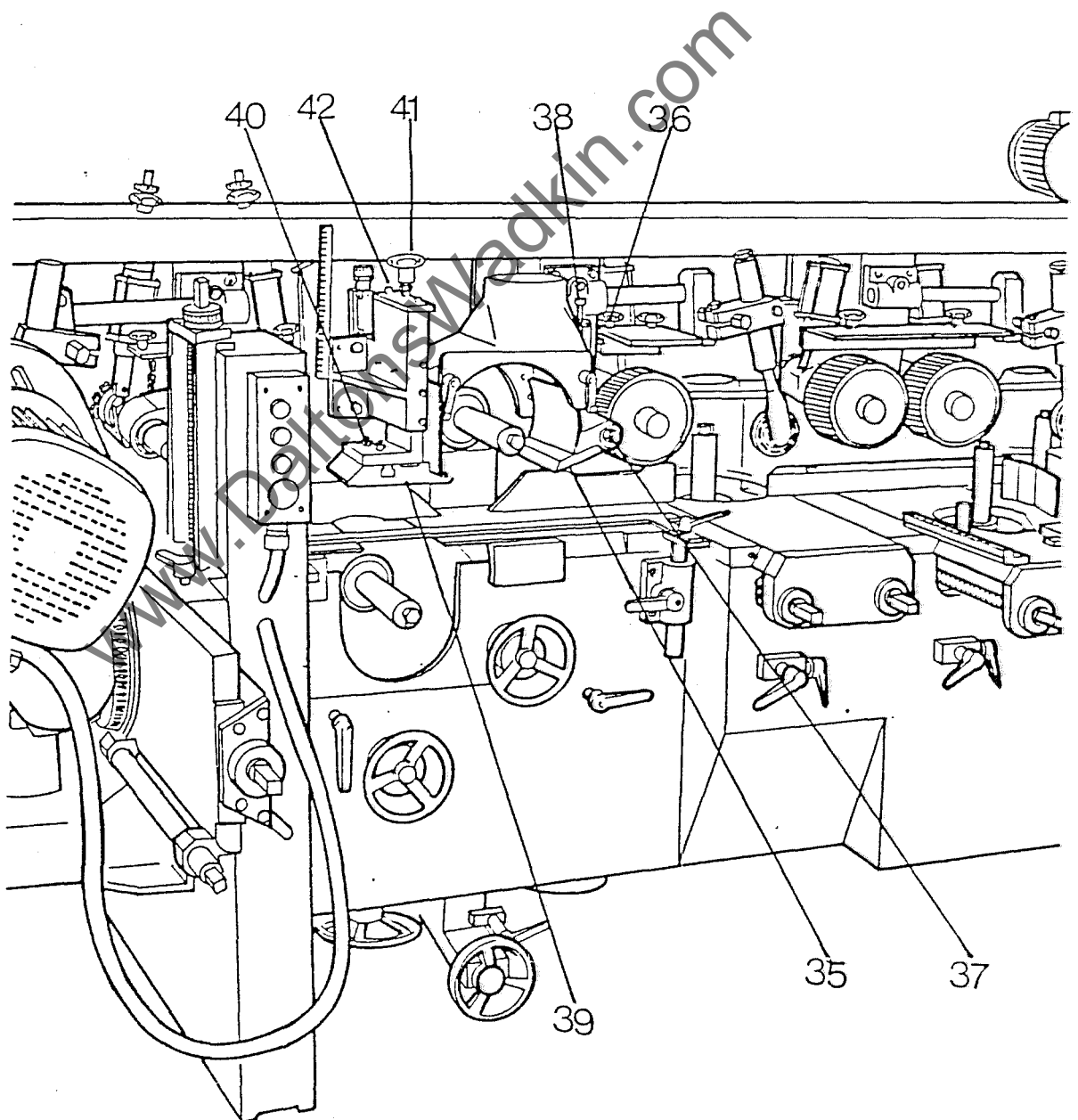

3.1.7 The Second Bottom Horizontal Spindle

The second bottom horizontal spindle is arranged to accept a cutting circle diameter of 100 to 180mm.

The spindle can be adjusted vertically and laterally. The vertical adjustment is such that a 180mm. diameter saw can be accommodated below a wooden bedplate 10mm. thick. The amount of lateral adjustment is 50mm. The vertical adjustment can be made in increments of 1/10mm.

The adjustable bedplates before and after the spindle can be arranged to suit the required diameter of the cutterblock. Under the bedplate after the spindle a 0.5mm. sheet steel plate of uniform gauge can be inserted to give a 0.5mm. cut.

To adjust the spindle (6) vertically. Unfasten locking lever (43) and turn handwheel (44) clockwise to raise the spindle and anti-clockwise to lower the spindle. After making adjustments re-tighten locking lever (43).

To adjust the spindle (6) laterally unfasten locking nut (45) at rear of machine and turn handwheel (46) at the front of the machine. Turn handwheel clockwise to move the spindle forward and anti-clockwise to move the spindle back.

After making adjustment re-tighten locking nut (45).

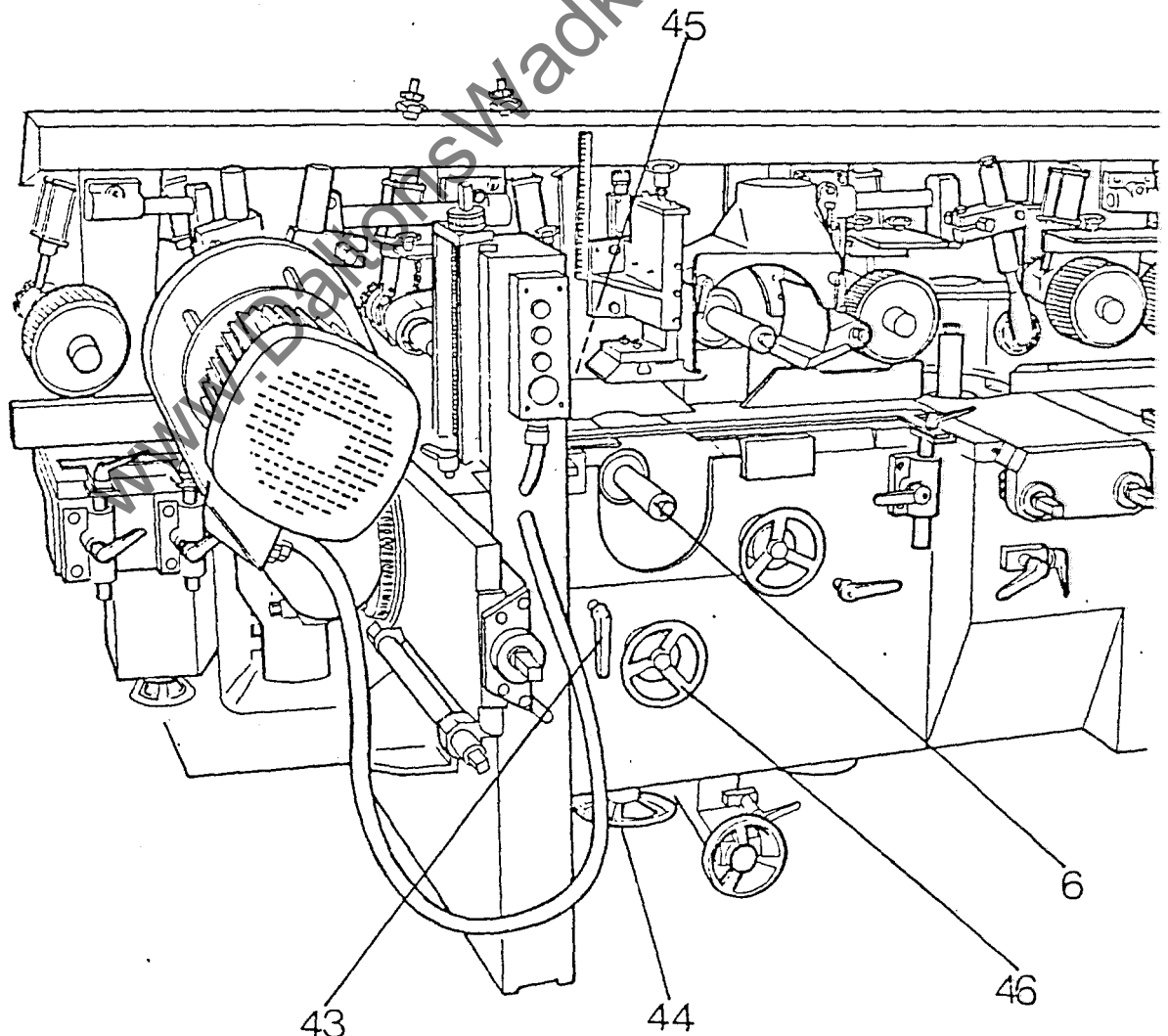

UNIVERSAL HEAD

REVERSING SWITCH

There are two types of switch used. A 25amp switch for all motor sizes up to 15HP.(11KW). situated at the Infeed end of the Control Console, and a 60amp heavy duty switch for a 20HP.(15KW) motor, situated on Infeed wall of Electrical Cabinet.

With switch turned to right looking towards Outfeed end of machine the Universal Head motor rotates clockwise when viewed on Fan end of motor, making it suitable for use as a Bottom Head, or Fence Side Head if 4 position Universal Head is fitted.

With switch turned to left the motor rotates in a counter-clockwise direction for use in Top Head or Nearside Head positions.

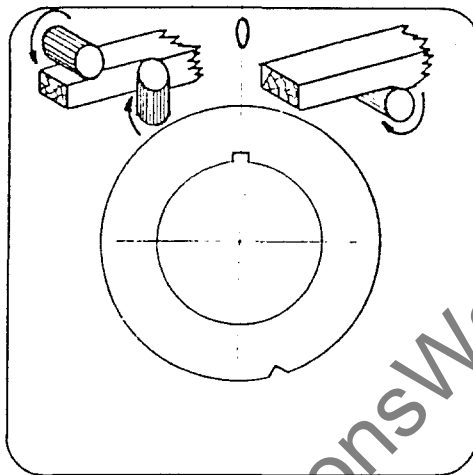

3 POSITION UNIVERSAL HEAD

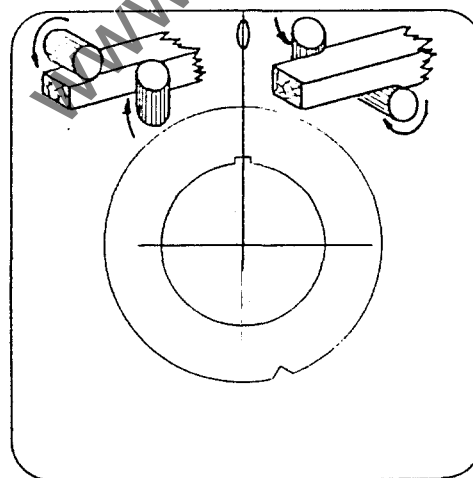

4 POSITION UNIVERSAL HEAD

3.1.8 Universal Head in the Near Side Vertical Mode. www.DaltonsWadkin.com

The Universal head in the Near Side Vertical mode will accommodate a cutterblock having a cutting circle diameter of 100 - 180mm.

The spindle can be canted between the horizontal and vertical modes.

The vertical and lateral movements can be precisely adjusted, from readings on a calibrated dial graduated in increments of 0.1mm.

Before and after the spindle the two adjustable bedplates are arranged to suit the cutting circle of the cutterblock in use when the spindle is in the bottom position.

If the spindle is in the canting position OR in the top horizontal position, metal rails are provided as bedplates. The forward rail is fixed by means of two square headed bolts. In this case the outfeed table is adjusted vertically to the same height as the bedplate after the Second Bottom Head. To adjust the spindle vertically - loosen the locking handle (49). Place crank handle on square (48) and turn clockwise to raise spindle OR anti-clockwise to lower. After adjusting re-tighten the locking handle (49).

To adjust the spindle laterally - loosen locking handle (47). Place the crank handle on square (50) and turn clockwise to move forward OR anti-clockwise to move back. After the adjustment re-tighten the locking handle (47).

To cant the Universal spindle unscrew the two hexagon nuts (51) at the spindle carriage and turn the square (52). The angle of cant is measured on graduated scale (53). Adjust the canting position of the spindle by means of this scale. Re-tighten the two hexagon nuts (51).

To reverse the direction of rotation of the Universal head operate the rotary switch at the electrical control station. The choice of rotation depends upon the position of the spindle. Before commencing to work, momentarily run the spindle to check the direction of rotation.

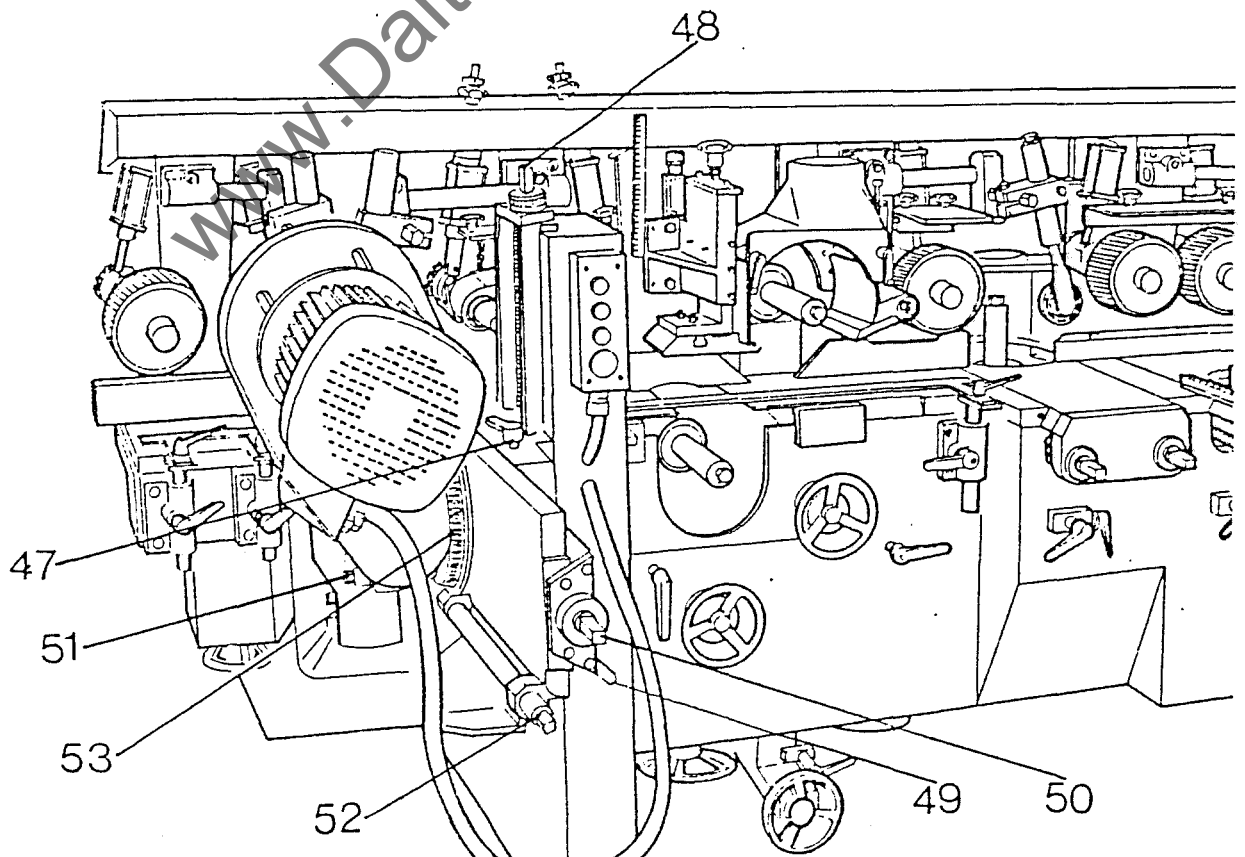

3.1.8 Universal Head as a Bottom Horizontal Spindle

Remove the dust hood which covers the spindle, by unscrewing the fixing screws with the assistance of a 5mm. hexagon key.

Fix the extractor hood (54) on the frame support of the machine by means of two hexagon bolts size M8.x 12mm. long and connect the extraction pipe. Place the spindle in the required position under the table. In this position always change the cutterblock from the rear of the machine.

The adjustment of the cutterblock in relation to the bedplate (55) is the same method as used for the spindle in a vertical mode.

When working grooved, rabbet OR warped timber the infeed table may not grip the work, in consequence adjust the outfeed table (56) to the same level as the preceding table.

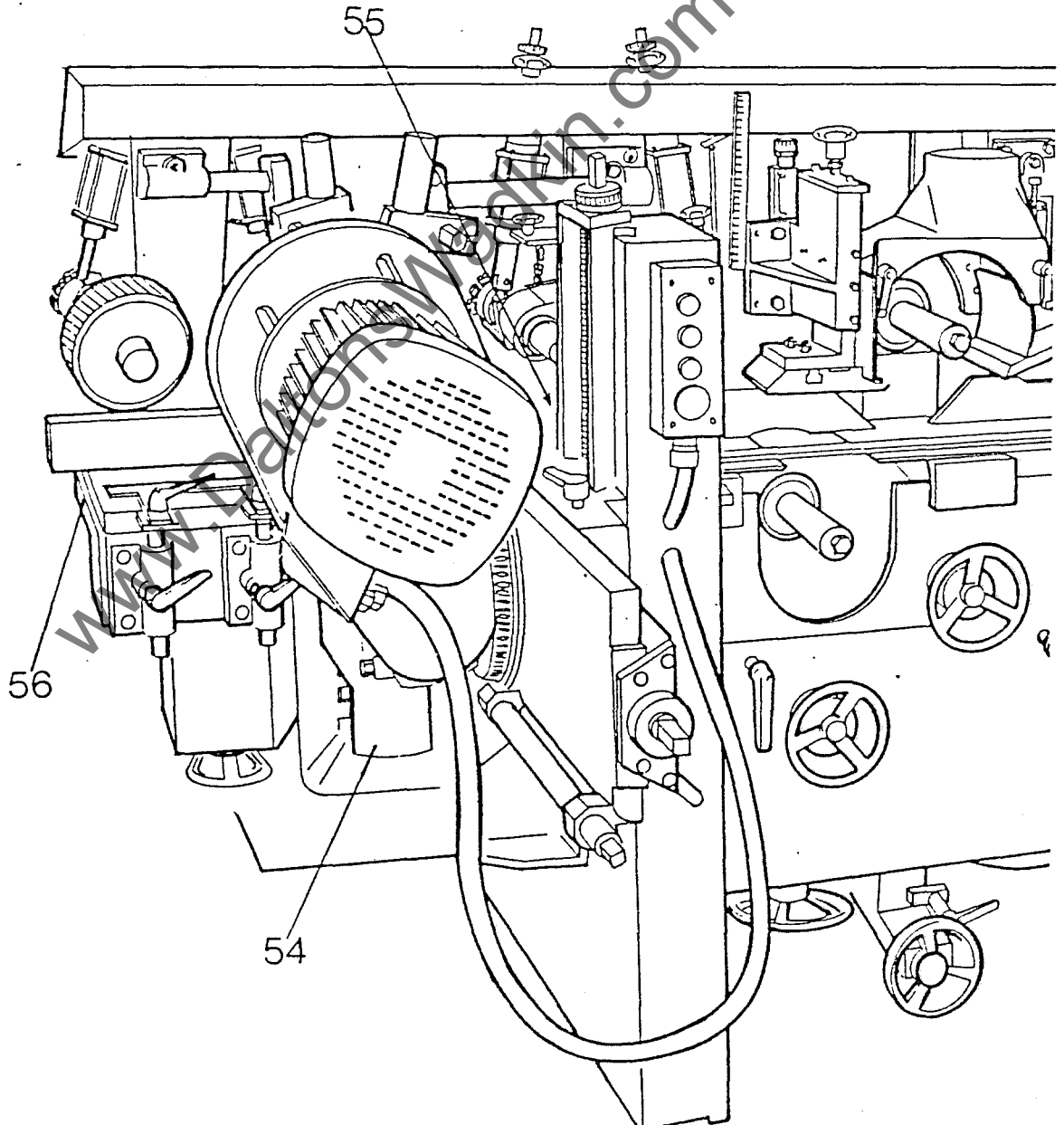

3.1.8 The Universal Head as a Top Horizontal Head. www.DaltonsWadkin.com

Fit the dust Hood (57). Remove the pressure rollers and the pressure shoes as well as their clamps and the support bars.

In raising OR canting the spindle take care that it does not come into contact with any part of the machine. Rotate the spindle each time and check the direction of rotation. Replace bedplates with the metal rails. The metal rails are placed side by side and the last one prevents the sideways movement of the others.

The metal rails ensure the transfer between the infeed and out-feed bedplates and guarantees a continuous feed.

Before feeding the timber make sure that the dust hood is not set too low and that there are no fouling points.

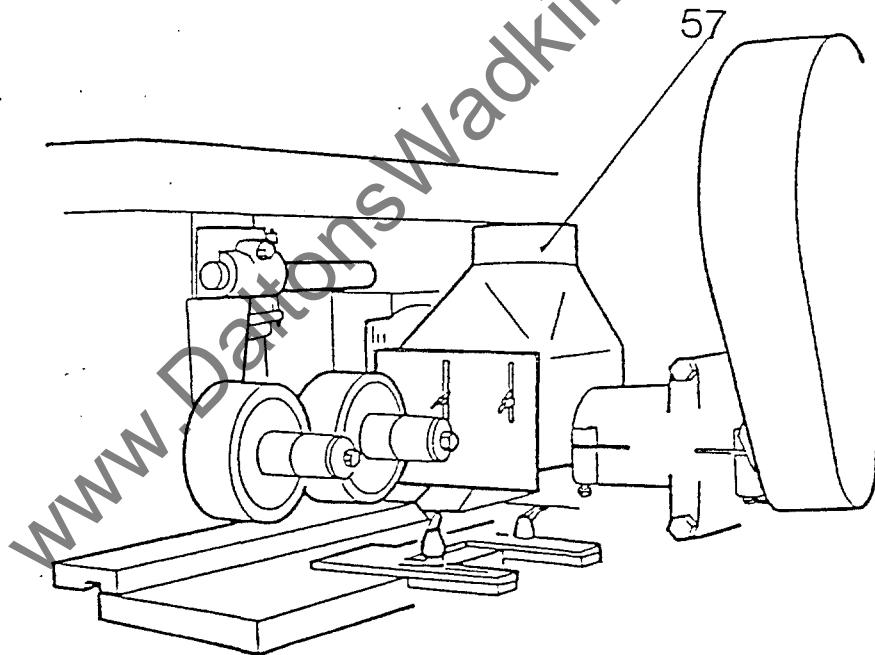

3.1.8 Universal Head as a Near Side Head.

In the Near Side vertical position including the canting position when the spindle is raised to the top horizontal position it is only necessary to remove the dust hood (54). * Place the metal rails wide enough to accept the widest piece of timber.

Accurately adjust the roller pressure, the wooden pressure shoes and the side guides on the first piece to ensure a smooth feed. Rotate the spindle in each mode and check the direction of rotation.

*.....See page...26

3.1.9 Universal Head as Fence Side Head.

Set spindle in a vertical position as for near side head.

Remove intervening bedplates and dust hood.

Move spindle across to fence side position.

Replace dust hood.

Replace metal rails as for top head.

NOTE:

Cut-out in side of rail to be positioned opposite the spindle.

Clamp rails side ways with outside rail (GA 393).

Set fence noses to suit cutterblock. Add side and top pressures as required.

Check rotation of cutterblock - ensure that it does not foul the bedplates and that it also rotates in the correct direction.

Controls of spindle are similar to those used for near side head.

NOTE:

Either a 3 position OR 4 position Universal Head is offered as an optional extra.

NOTE:

A driven bottom outfeed roll can be fitted to machines with gear driven feedworks.

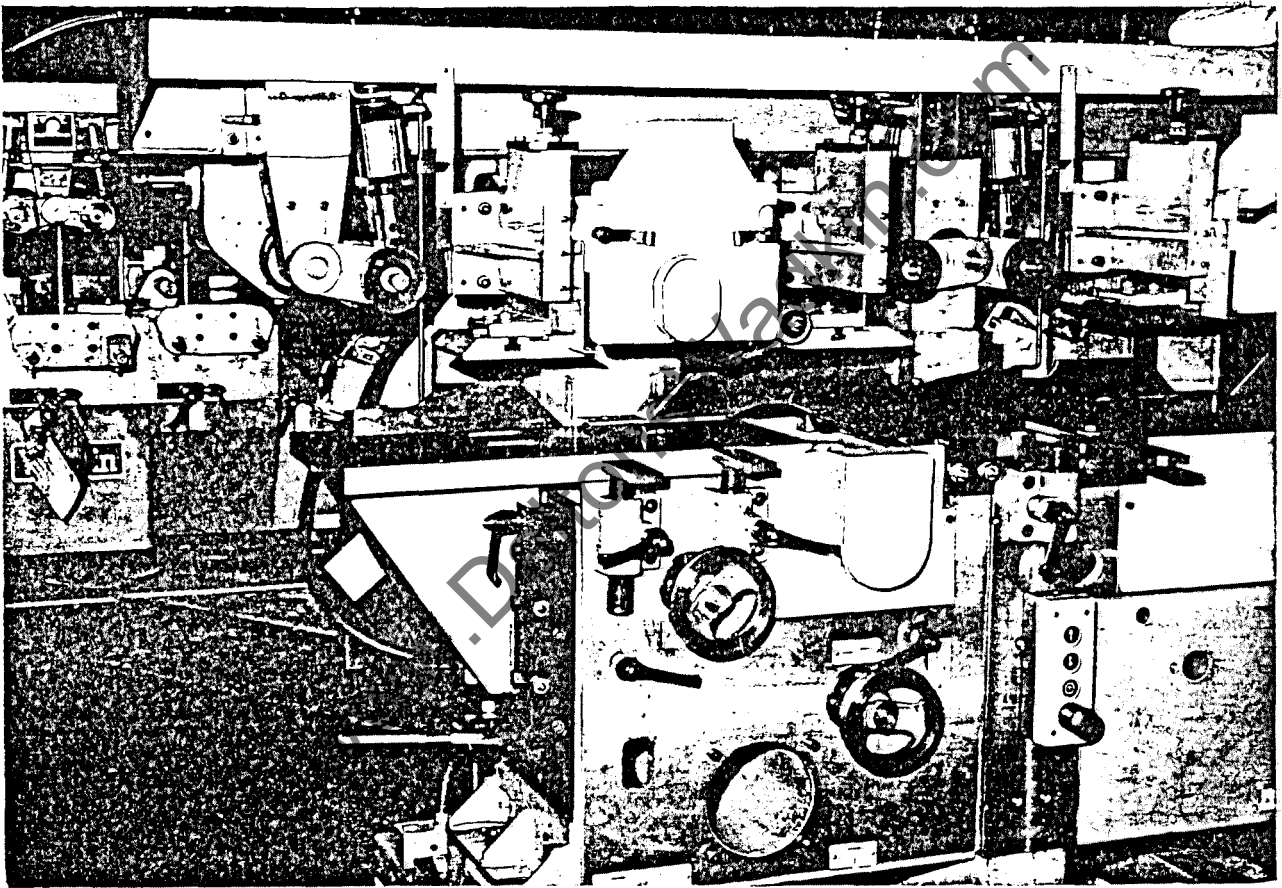

ADDITIONAL BOTTOM / TOP HEADS CLOSE COUPLED - WHERE FITTED

THROATING HEAD - WHERE FITTED

The throating head can be used in either Top OR Side head cutting mode. A switch for setting direction of rotation is provided on the Control Panel.

When converting mode of operation remove the flexible hose and hood, slacken nuts on motor mounting and rotate motor through 90°. Slacken nuts on radial clamps - rotate pulley belt housing to re-position cutter towards either Fence (side head) Bedplate (Top head). Re-tighten nuts.

After slackening slide nuts - the rise and fall and transverse adjustments can be made, using the appropriate screw. Re-tighten slide nuts and refit hood and flexible hose.

BEFORE CUTTING ENSURE CUTTING TOOL HAS BEEN CORRECTLY MOUNTED FOR DIRECTION OF ROTATION.

www.DaltonsWadkin.com

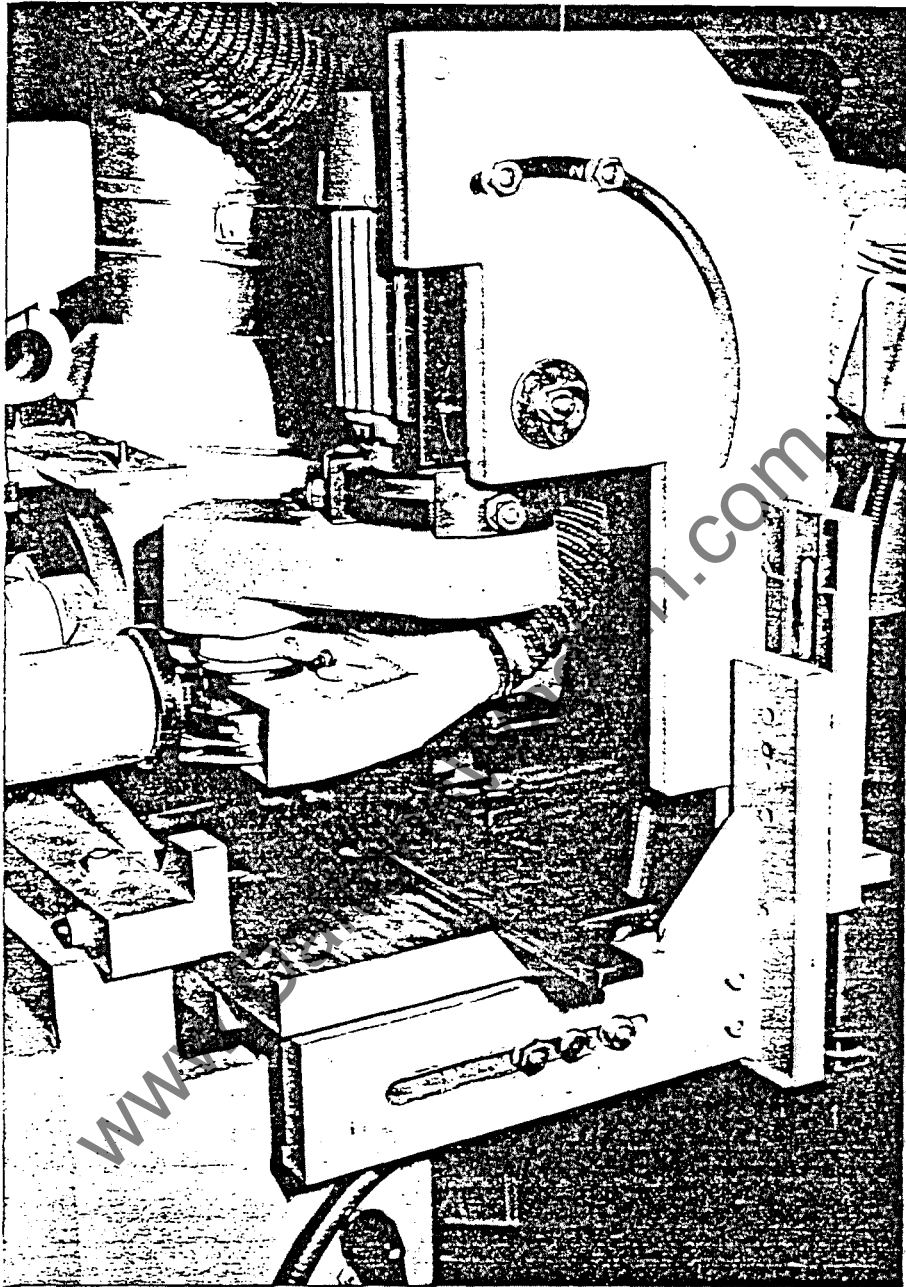

THROATING HEAD
(WHERE FITTED)

3.1.10 The Canting Fence Side Head. (WHEN REQUIRED)

The mounting and the location of the adjustments of the canting fence side head (4) are the same as the fence side head.....See 3.1.4.

The vertical head can cant up to 45°, unscrew the hexagon nut and cant the spindle by ratchet.

Tighten the hexagon nut in the new position.

After loosening the bolt, bring the bedplate forward to about 5mm. from the cutterblock.

Tighten bolt.

Cheek plates for the Fence Side Canting head exhaust hoods are supplied as blanks for the Customer to modify to suit the working angle of the canting head.

Right Hand Cheek Plate - GA. 745

Left Hand Cheek Plate - GA. 746

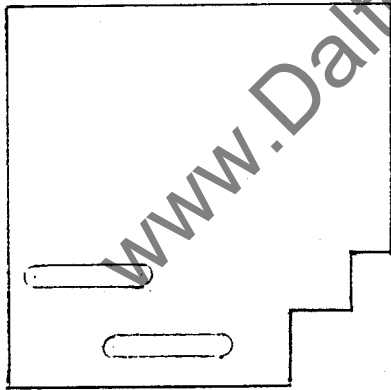

GA 746

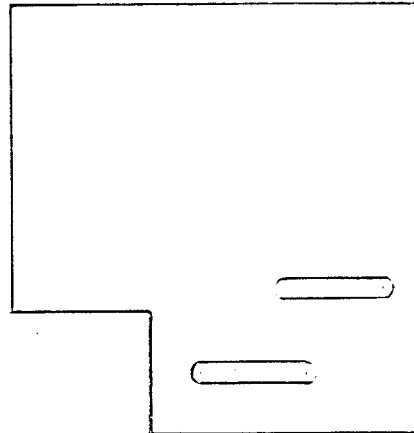

GA 745

ILLUSTRATION OF CHEEK PLATES

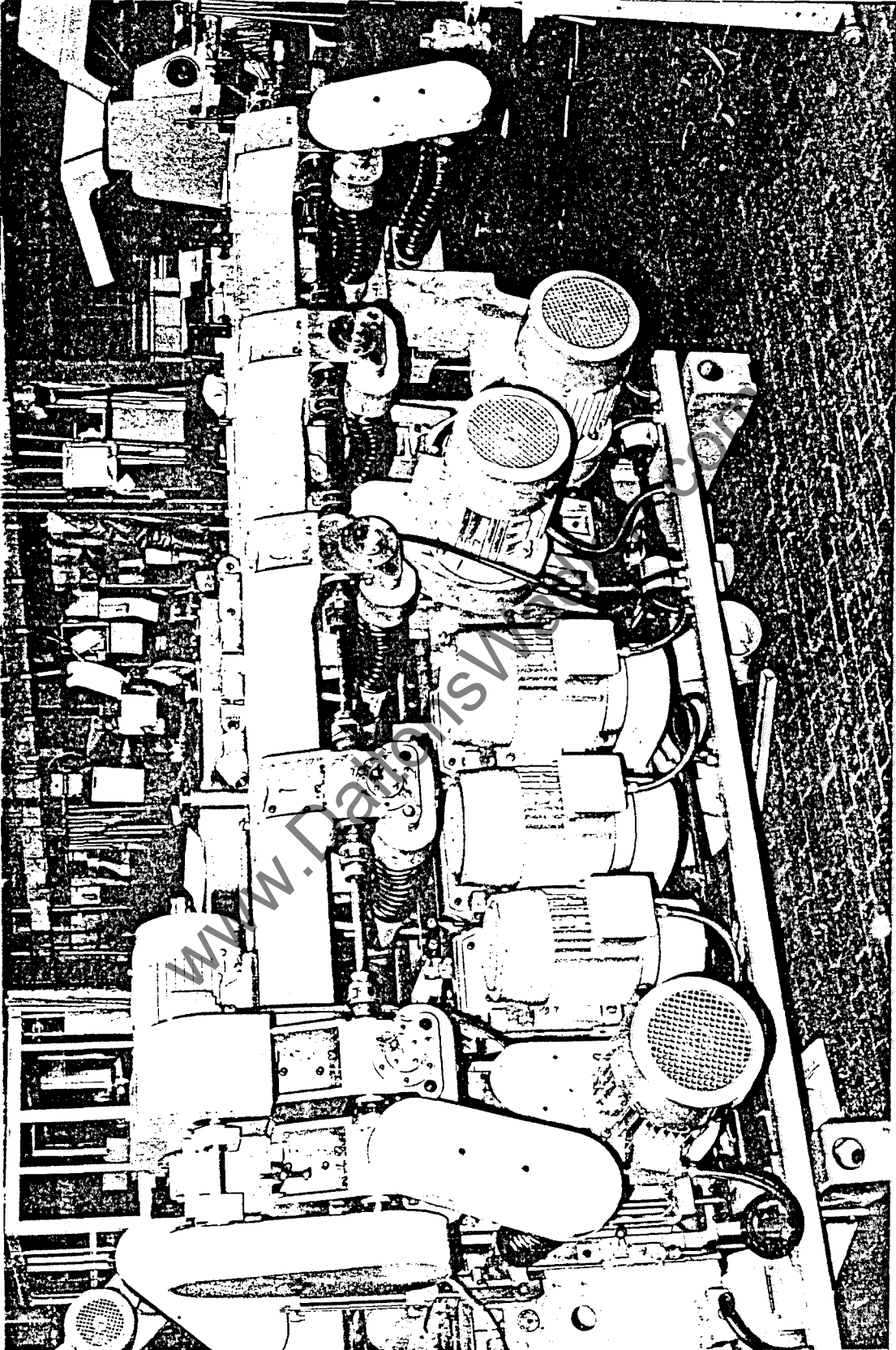

REAR VIEW OF MACHINE SHOWING GEAR DRIVE TO TOP AND BOTTOM FEED ROLLS (WHERE FITTED)

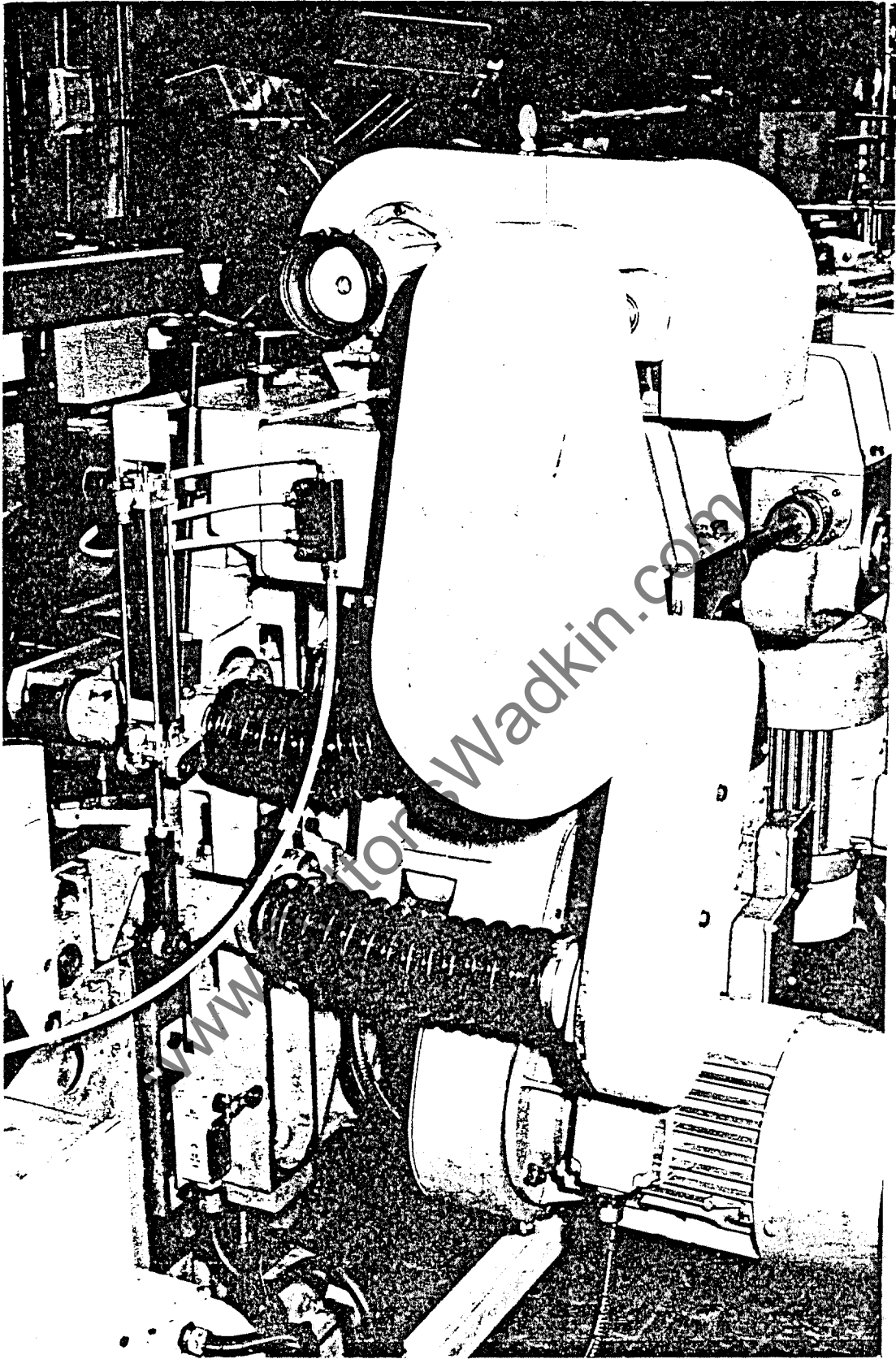

VIEW SHOWING DRIVE TO TOP AND BOTTOM INFEEED ROLLS (WHERE FITTED)



VIEW SHOWING DRIVE TO TOP AND BOTTOM FEED ROLLS AT UNIVERSAL HEAD (WHERE FITTED)

3.1.11 The Feedworks.

The automatic moulder has a continuous feedworks.

The short space between the feed rolls ensures a perfect path for the feed.

The speed of the feed is infinitely variable, adjusted by means of a handwheel (63) to give speeds between 6.0 to 28m/min. (6.0 to 36)m/min.

NOTE: DO NOT ADJUST WHILST STATIONARY.

The diameter of the feed rolls is 140mm., are available in widths of 50mm, 20mm. and 10mm. and can have spiral teeth, diamond knurled teeth for hardwoods OR can be rubber covered.

Spring pressure. The roller pressure can be adjusted by means of the knurled screw at the top of the pressure. If the screw is turned through a distance of 5mm. the pressure on the roller is about 250 N. (25kg). if the screw is turned to its maximum limit of 16mm. then the pressure at the roller is about 500 N. (50kg).

Pneumatic pressure can be supplied to special order. The feed rolls before the First Bottom Horizontal head, together with those after the First Top Horizontal head and at the Outfeed table can be adjusted independently by hand. This permits the rolls to be adjusted to give optimum results.

The air pressure should be adjusted to give

3 - 4 atm	for steel rolls
2 atm	for rubber covered rolls



1 atm corresponds to a pressure of 64 N. (6.5kg).

Raise the feed rolls to avoid any difficulties before surfacing.

All the feed roll driving shafts are arranged for quick changeover of the feed rolls and packing spacers. To change the feed roll (64). Unscrew the screw (65) at the end of the drive shaft with a 10mm. hexagon key, remove the washer (66) change the intermediate spacers and the feed rolls, replace the washer (66) and the screw (65) at the end of the drive shaft.

Do not remove the roll safety guard (67). The sheet metal safety protector (68) must be set about 20mm. higher than the lowest edge of the feed roll.

The serrated feed rolls must be adjusted 5mm. lower than the thinnest workpiece.

Adjust by pressing the push button marked  for raising OR  for lowering, these are located at the Electrical Control Station (70) at the infeed end of the machine. Read the height of the adjustment direct from the scale (69). The height of the adjustment of the rubber covered rolls is made independently. The rubber cover rolls must be adjusted to rise by not more than 3mm. On each swing support there is a clamp for fixing the complementary telescopic pressure (71) OR wooden pressure shoes.

The feed transmission drive is varied by mechanical means.

NOTE: THE DRIVE TO THE FEEDROLLS IS EITHER BY A CHAIN DRIVEN SYSTEM OR A GEAR DRIVEN SYSTEM.

NOTE: A DRIVEN INFEED BOTTOM BEDROLL CAN BE FITTED TO THE MACHINES WITH GEAR DRIVEN FEEDWORKS AND AN OUTFEED DRIVEN BEDROLL CAN BE FITTED TO THE 3 POSITION UNIVERSAL HEAD.

3.1.11 The Feedworks.....contd.

The Pedestal mounted control station at the infeed end of the machine contains the following:-

Push Button START and STOP - indicator lamp for each spindle arbor.

START and STOP Feed Button - indicator light.

Forward and reverse (inch) Feed buttons (optional extra)

Raise and lower buttons for beam.

Master "STOP" button

Reversing switch (for universal head when supplied).

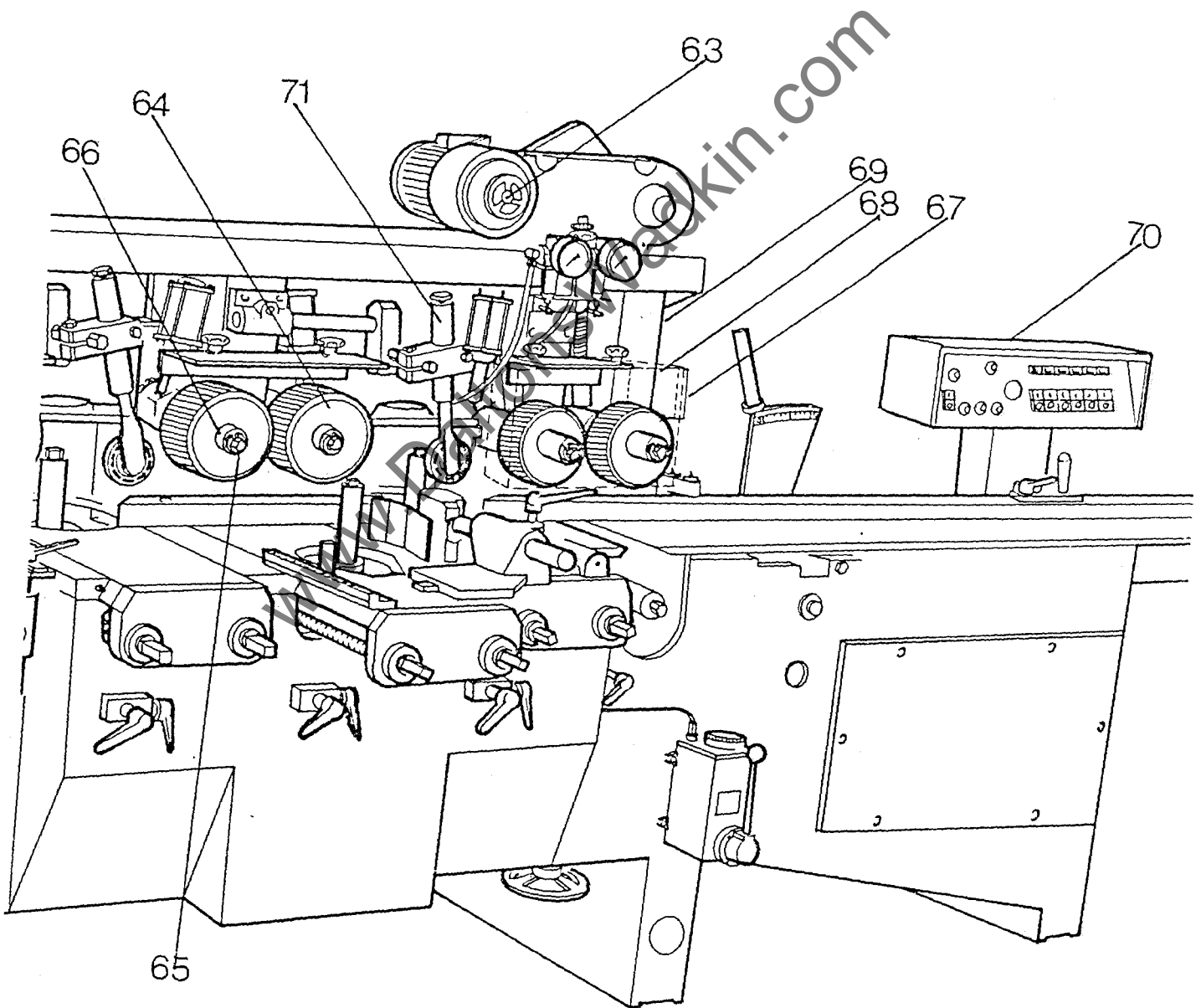

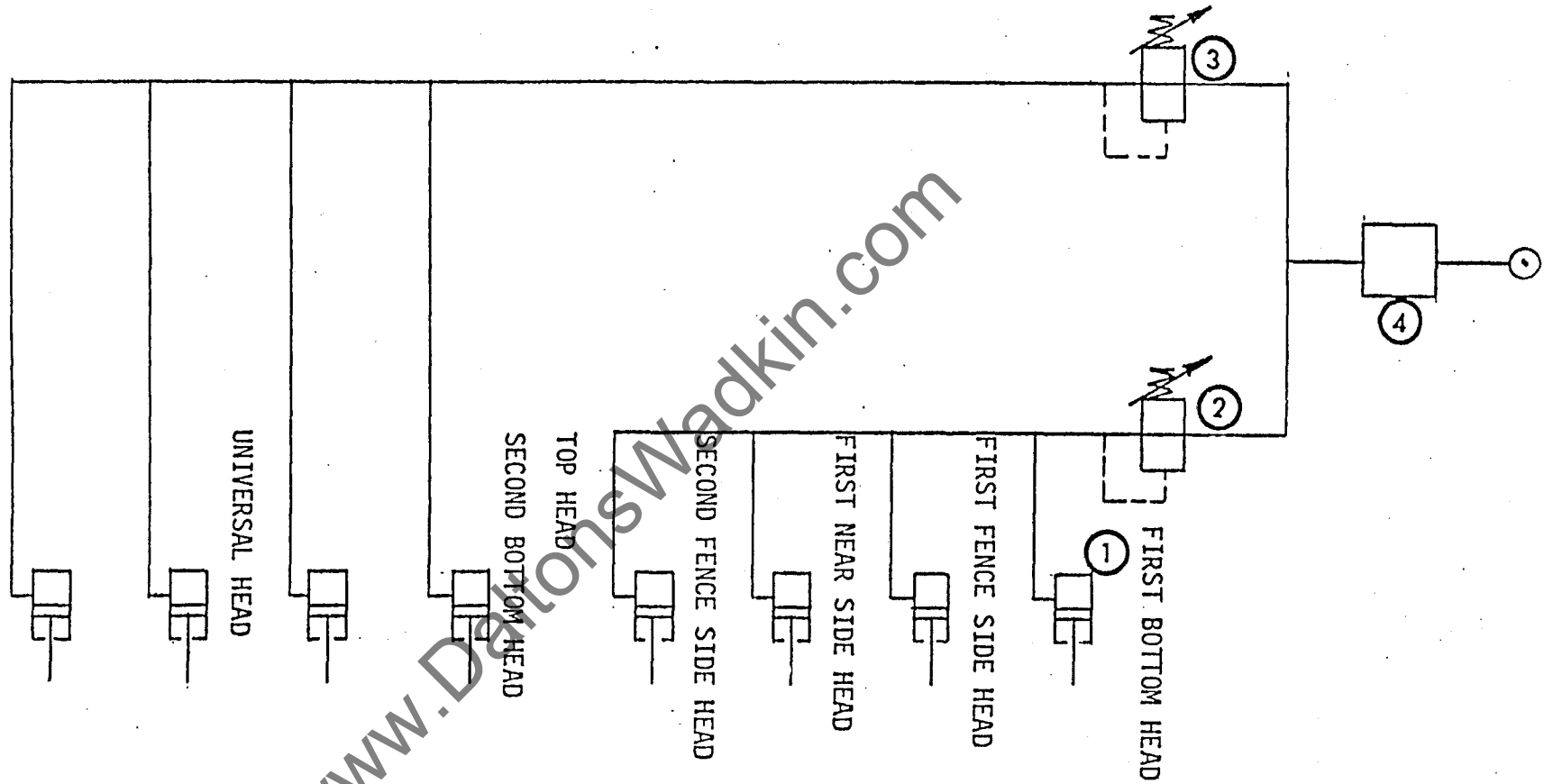

- ① INFEEED ROLLS
- ② PRESSURE REGULATOR FOR FEED ROLLS BEFORE TOP HEAD
- ③ PRESSURE REGULATOR FOR FEED ROLLS AFTER TOP HEAD
- ④ FAIL SAFE SWITCH (OPERATES WHEN PRESSURE DROPS BELOW 20 P.S.I.)

FEEDWORKS - TYPICAL PNEUMATIC CIRCUIT TO FEEDROLLS

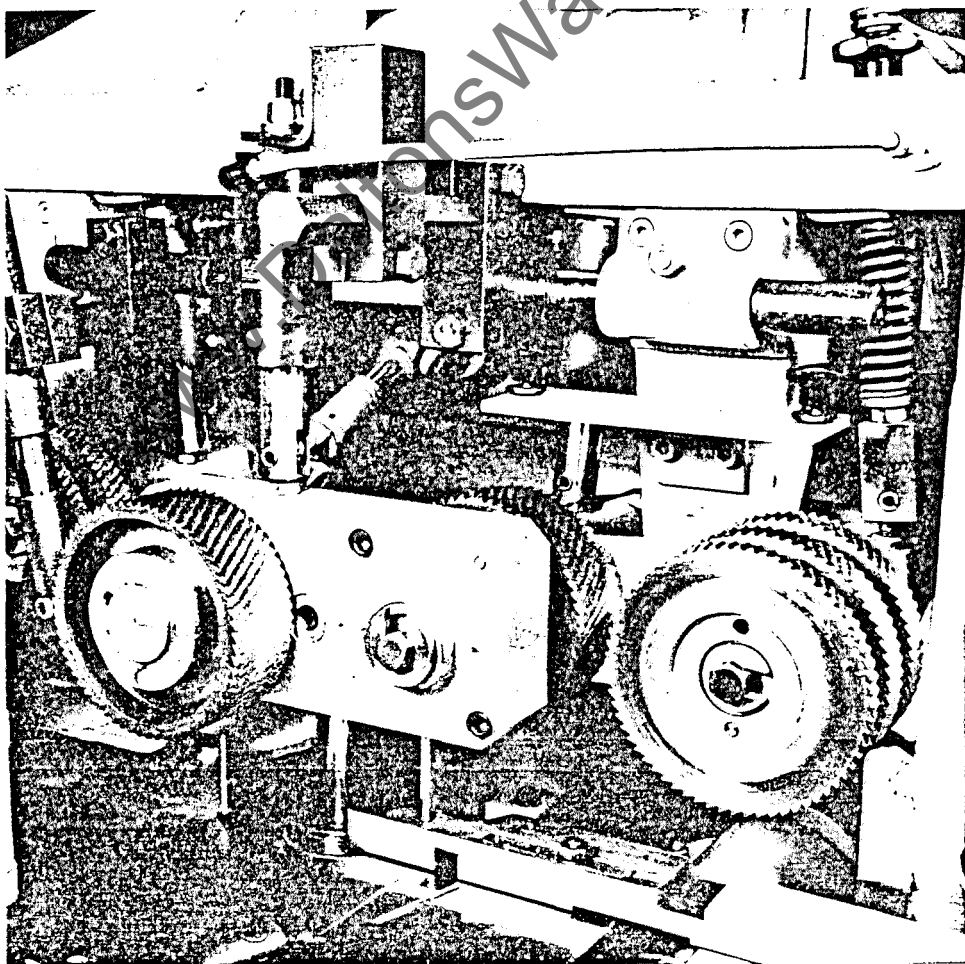
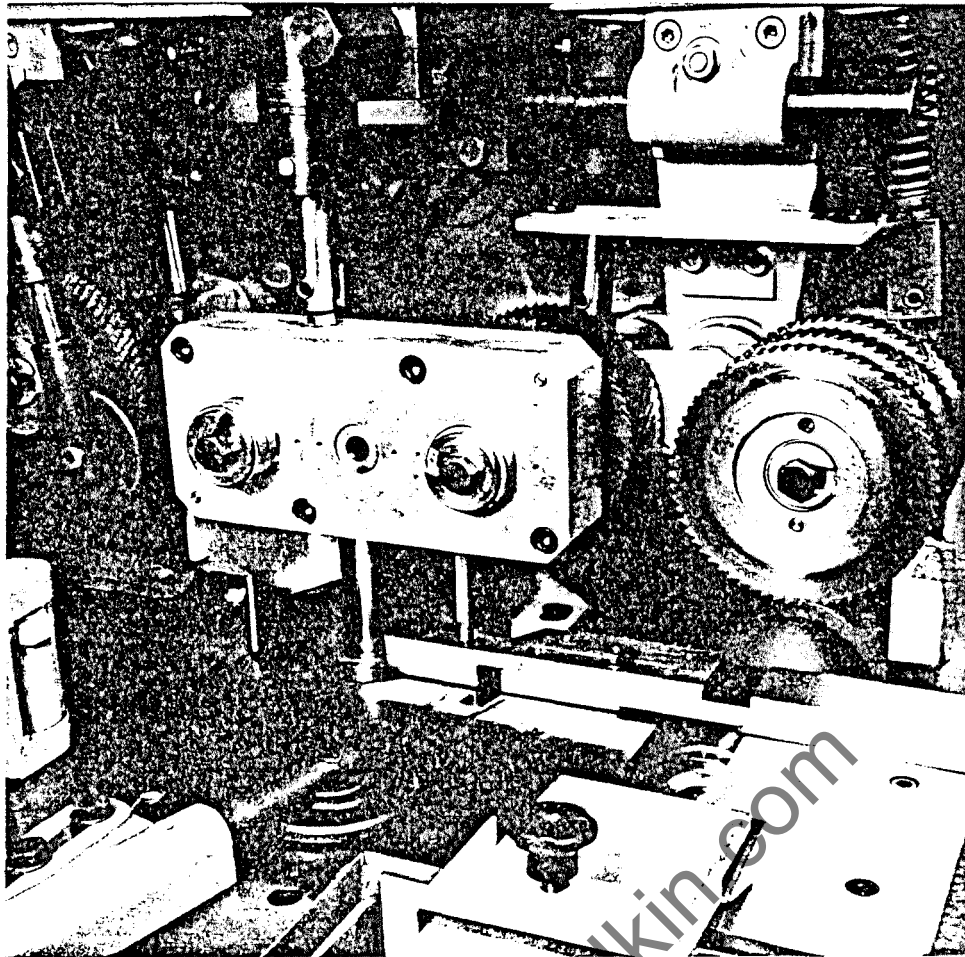

INTERMEDIATE FEED ROLLS - ALTERNATIVE POSITIONS SHOWN
(WHERE FITTED)

3.2 Putting the Machine into service.

Lubricate the machine thoroughly before putting into service. All the important particulars of maintenance and lubrication are documented in Paragraph 4.

After becoming familiarized with all the various controls and making certain that all the spindles rotate normally, start the machine.

3.3 Check the direction of rotation and the position of the heads.

Start each motor separately and check the direction of rotation of the spindles.

Also check the direction of movement of the beam raise and lower motor and the feedworks motor.

3.4 Fitting and Adjusting the Cutterblocks.

To change the cutterblocks, remove the cover of the dust hoods. Unscrew the nut of the spindle with the combination spanner supplied with the machine.

For this purpose place the combination spanner on the hexagon of the spindle and on the two flat faces of the spindle nut. Hold the spanner firmly from the bottom and unscrew the nut with the spanner from the top. All the bottom horizontal spindles and all the near side vertical head spindles have left hand threads. All the top horizontal and fence side vertical heads have right hand threads.

Before fitting the new cutterblocks, carefully clean the spindles, their sleeves, the cutterblocks and the intermediate spacers.

Carefully place the cutterblocks on the spindle and add the intermediate spacers if necessary. Do not overlook the locking collar of the universal head spindle. Screw the spindle nut and tighten thoroughly with the double end spanner. Do not use a box spanner. Do not use an extension spanner on this spindle.

Do not use any form of percussion tools.

Turn the spindle by hand to check that the cutterblock is free running. Close the cover.

Operate the spindle for a short time and check that it freely rotates.

The spindle must rotate free of vibration.

To avoid damaging the ball bearings - take care not to allow the cutterblock to fall on the shank of the spindle.

3.5 Putting the Machine into Service

After familiarizing yourself with the machine from the preceding paragraphs, commence to make adjustments of the machine.

We describe the operation of a machine with seven spindles in the following sequence:-

Surface Planing

Edge Trimmer

Vertical Left Near Side.

Vertical Right Fence Side.

Top Horizontal Spindle.

Bottom Horizontal Spindle.

Universal Spindle.

In the case of other spindle positions, the adjustments are made relative to these.

3.5.1 Surface Planing.

Fit the cutterblock. Place the straight edge on the table after the surfacer (1). Set the cutterblock to the point where the rotating knives lightly touch the straight edge. Decide on the required chip thickness.

For rough planing set the infeed roll before the surface planer. For working large section OR short pieces it is best to set the feed roll in the middle of the piece and apply a light pressure.

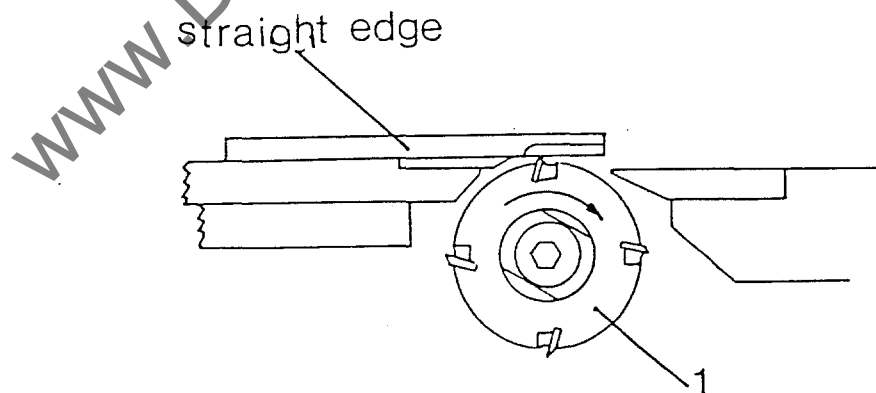

3.5.2 Edge Trimming - (Jointing)

Before proceeding with the setting of the edge jointing (fenceside) spindle (2), set the thickness of chip (cut) at the Second Fenceside head (4).

Place a straight edge on the fence after the Second Fenceside head, rotate the spindle so that the knives lightly touch the straight edge. * Set the cut by adjusting the fence between the edge jointing spindle and the second fence side head, as in.....3.5.4.

Place the straight edge on the fence nose piece (20) after the edge jointer, set the spindle so that when rotated the knives lightly touch the straight edge.

Set the thickness of cut.

Adjust the fence nosepieces, before and after the edge jointing spindle to about 5mm. clear of the cutting circle.

Adjust the top pressure roller.

*.....See page 36

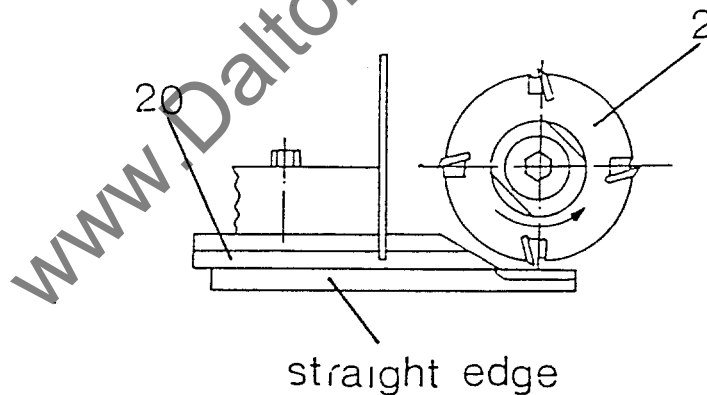

3.5.3 First Vertical Near Side Head.

Fit the cutterblock. Adjust the Chipbreaker in front of the spindle. Adjust the fence after the spindle. To do this place the straight edge on the fence and adjust the cutterblock so that the knives lightly touch the straight edge. (If the profile knives are required, adjust to the smallest cutting circle). Place the nosepiece about 5mm. from the cutting circle of the knives. Set the height of the spindle as a reference to a known datum. For example to the middle of the cutterblock locking ring. Use the calibrated dial to set the width. Provide a wide feed roll to suit the width of the work both before and after the vertical spindle.

3.5.4 Second Vertical Fence Side Head.

Fit the cutterblock. Place the straight edge on the fence after spindle (4). and adjust the cutterblock in such a way that the rotating knives lightly touch the straight edge. In the case of profile cutters adjust to the smallest cutting circle. Adjust the height on the graduated dial to a given dimension. Set the fence nosepiece before and after the second vertical head at about 5mm. from the maximum cutting circle of the cutterblock. Adjust the top roller pressure.

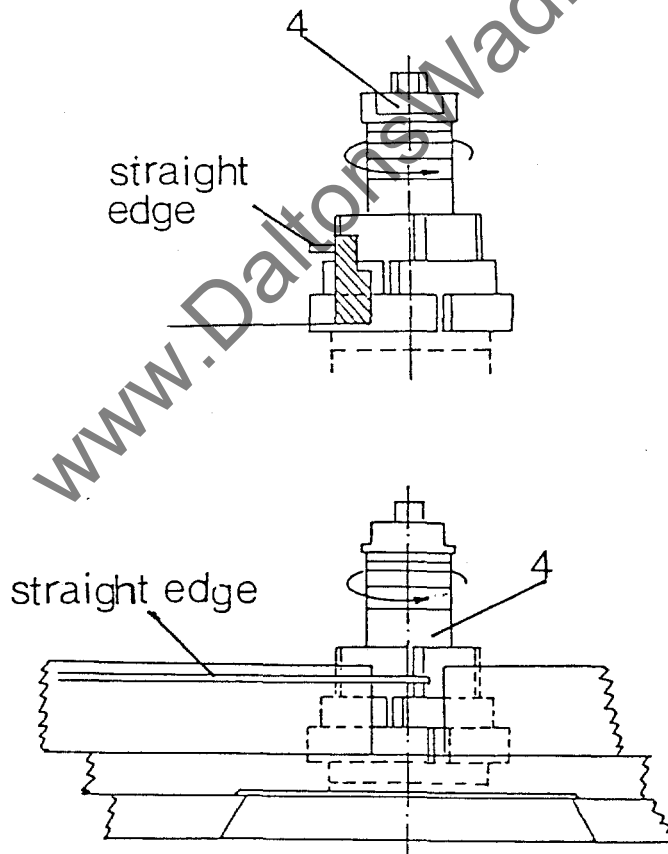

3.5.5 Top Horizontal Spindle.

Fit the cutterblock. Adjust the height of the infeed chipbreaker to suit the cutting circle of the cutterblock. Adjust the pressure shoes after the spindle to the smallest cutting circle of the cutterblock. Place the straight edge under the pressure shoes, so that the rotating knives of the cutterblock lightly touches the straight edge. A profile guide can be made to suit the workpiece. Engage the automatic adjuster - loosen the locking lever of the clamp and position the spindle by the aid of the calibrated dial.

Disengage the automatic adjuster.

Adjust the spindle laterally.

3.5.6 Bottom Horizontal Spindle.

Fit the cutterblock. Locate the bedplates before and after the spindle to suit the diameter of the cutterblock. Adjust the infeed bedplate to suit the timber. Then adjust the spindle (6) for height so that the rotating knives of the cutterblock lightly touch the straight edge. Adjust the lateral movement of the spindle. For small thicknesses of work it is best to adjust the bedplate and the spindle before adjusting the bottom spindle for thickness.

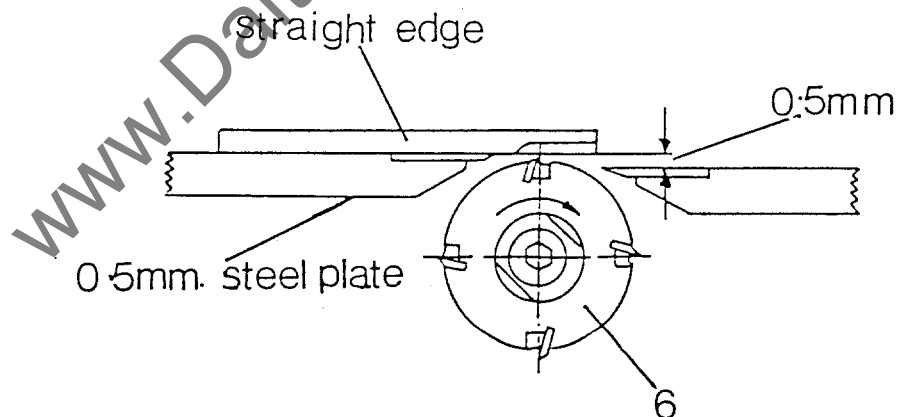

3.5.7 Universal Spindle in the Bottom Horizontal Mode.

Place the spindle in the working position.

Fit the cutterblock. Adjust the bedplates, the outfeed table to suit the spindle see.....3.5.6. Mount the pressure shoe above the Universal cutterhead spindle.

3.5.8 Universal Spindle in the Top Horizontal Mode

Place the spindle in the working position.

Put the outfeed table at the same height as the infeed bedplate and change the bedplates for the metal rail, mount the safety hood.

Fit the cutterblock. Adjust the spindle both laterally and vertically by reading off the calibrated dial. Mount the pressure shoes before and after the cutterblock arbor.

3.5.9 Universal Spindle in the Near Side Vertical Mode

The same adjustments as.....3.5.8. Only put the metal rails to suit the width of the work.

3.5.10 Feedworks.

Adjust to suit the thickness of the work, the feed speed and the air pressure for the rolls.

www.DaltonsWadkin.com

The covers of the dust hoods must be closed during the time in which the machine is running. Cover the non-used part of the cutterblock of the planing machine.

Only remove the feed roller guard when about to change the rollers. The sheet steel guard should be about 20mm. higher than the lower edge of the drive rollers.

Spindles which run in two directions should be fitted with a locking collar to avoid unforeseen unlocking.

Do not work the spindles when the spindle nuts OR intermediate collars are not tightened.

Only remove the cover of the belt housing when changing the belts OR to re-tighten them.

THE USE OF CIRCULAR SAWBLADES.

When a single circular sawblade is being used on a work spindle, a wood splitting wedge is sufficient protection to avoid the kick backs of the wood being sawn.

When several circular sawblades are being used on a work spindle, a protective clamp must be fitted in front of the sawblades, to avoid the kick back movement of the wood being sawn, and this should cover the whole gang of saws.

These safety devices to prevent kick back movement of the wood can be supplied for all machines.

ATTENTION:

All slides, all separate devices and the whole of the safety equipment and accident prevention guards found on our machines should be left in position. They should under no circumstances be taken off! If you remove these standard parts before OR during the use of the machines, you run the risk of causing accidents. In this case, we do not accept any responsibility for damage OR accidents which occur.

STUDY YOUR OWN SAFETY!

3.7

Machine Test and Trial Run.

The machine is adjusted as in.....3.5 for a given profile. Set all the spindles that are required to work. Put in the first piece of wood and slowly move it forward up to the near side (left) vertical head using the inch forward feed pushbutton. Ascertain that the side pressure rollers (if fitted) and the top roller pressures are in the normal position. From the near side head onwards, it is easier to observe the piece of timber from the end of the machine.

Continue to move the piece of timber slowly forward and gradually place the side fence against the timber and tighten.

Adjust the pressure shoe after the first top horizontal head spindle on the first piece of wood by moving the shoe about 0.5mm. measured at the opening underneath the cross shaped knob. (varies according to the amount of tension) See also.....3.1.6.

Adjust the rubber rollers to a height of 3mm. maximum. Check the timber after it has been through the machine. If necessary make dimensional corrections by the aid of the graduated scales of 1/10mm. increments from the spindles concerned.

www.DaltonsWadkin.com

The rollers in the table (To special order).

The rollers in the table should protrude by about 0.1 to 0.15mm. from the tables. This measurement is made when the machine is under load. To achieve this, place the workpiece 100mm. thick and 50mm. wide and move it to the middle of the rollers by means of the feed rolls. Measure and adjust the height of the rollers in the table.

Faults in the Workpieces and their causes.

Scars in the loading end of the stock - the cutterblock is too low in relation to the outfeed table. Adjust the cutterblock correctly.

Scars on the far rear end (Trailing) of the stock the cutterblock is too high in relation to the outfeed table. Adjust the cutterblock correctly.

The top side of the trailing end of the stock shows scars and lacks cleanliness of cuts, the pressures are badly adjusted, adjust the pressures correctly and check the varying thicknesses encountered in the run.

Nicks in the wood during Planing.

The cutterblock is too low in relation to the outfeed table. The rear end of the stock is lifting from the table during planing. Raise the cutterblock slightly.

Hollows form in the stock during planing.

The cutterblock is too high in relation to the outfeed table. The rear end of the stock is sinking during planing. Lower the cutterblock slightly. To do this adjust the cutterblock lower than necessary and carry out the final adjustment from bottom to top to compensate for the play of the spindle adjustment.

Twisted OR Warped Stock after Planing.

The cutters are not parallel to the outfeed table OR they are badly ground. Adjust OR sharpen the tools carefully.

Faults caused by Tools.

Burn marks on the stock - Tools are blunt and need re-grinding.

Nicks in the cutting edges (especially carbide).

Generally these are caused by removing too much metal when re-grinding the knives. This results in undue stresses and subsequent cracking of the cutting edge and the metal breaks away when machining to cause nicks. To obviate this trouble take greater care when re-grinding knives.

Vibrating Tool Heads.

The tools have not been ground evenly and are not running true. Re-balance the tools.

4.1 Regular Cleaning of the Machine.

Our machines need a minimum of maintenance and care. We recommend that the machine be cleaned thoroughly once a week. In the case of cleaning with compressed air - take care not to direct the jet onto the spindle bearing housings, the moving shafts etc. Clean the spindles and remove all remains of resin and grease; do the same with the cutterblock collars and the machine tables (bedplates) and lightly lubricate them. Check that the parts slide well at the friction points and lubricate often as indicated in the lubricating instructions. This is absolutely essential for working on hardwood, such as Sipo (Utile) OR the like. Adjust the forward feed device once a week to avoid jamming the feed motor pulley sheaves.

www.DaltonsWadkin.com

4.2. Lubrication of the Machine.

In designing the "WADKIN" "GA" Moulders much attention has been given to the question of maintenance and every endeavour has been made to keep lubrication maintenance to a minimum. In consequence of which "sealed for life" bearings and "oilite" bushes have been widely used.

However, there are exceptions which are as follows:-

In electric motors where "sealed for life" bearings have not been fitted these are provided with grease nipples.

DAILY

Grease lubricate the Machine slideways and raise and lower and cross traverse screws with "WADKIN" Grade L6 grease.

The cutterblock spindles have been fitted with permanently lubricated bearings and should give trouble free service.

A hand operated lubricating pump is fitted to the machine to provide oil lubrication to the machine bed. The hand operated lever should be pulled outwards to eject the required jets of oil to the bed. At each pump a tap has been fitted so as to control the rate of oil flow.

The oil reservoir holds 1 litre (1.76 pints) of oil this should be re-plenished with "WADKIN" Grade L4 oil.

There is no requirement for periodic lubrication of the feed rolls motor driven variable speed unit.

NOTE: ON MACHINES FITTED WITH CHAIN DRIVEN FEEDWORKS, THE CHAINS SHOULD BE LUBRICATED AT LEAST WEEKLY WITH OIL CAN. ACCESS TO THE HORIZONTAL CHAINS IN THE TOP BEAM IS GAINED BY REMOVING COVERS ON TOP OF THE BEAM.

ON MACHINES FITTED WITH GEAR DRIVEN FEEDWORKS, THE UNIVERSALLY JOINTED DRIVE SHAFTS SHOULD BE GREASED AT THREE MONTHLY INTERVALS.

THE LEVEL OF THE OIL IN THE GEARBOXES SHOULD BE INSPECTED AT REGULAR INTERVALS AND TOPPED UP WITH GRADE L.2. GEAR OIL WHEN NECESSARY.

APPROVED LUBRICANTS

WADKIN	CASTOL	B.P.	SHELL	MOBIL	ESSO	GULF	CALTEX
L.1.	HYSPIN AWS 32	ENERGOL HLP 32	VITROL 32	DTE OIL LIGHT 24	NUTO 44 OR ESSTIC H44	HARMONY 43 AW	RANDO OIL HDA
L.2.	ALPHA ZN 150	ENERGOL HP 150 OR CS 150	VITREA 150	VACTRA EXTRA HEAVY	ESSTIC 65	SERVICE 13	URSA P40
L.4.	MAGNA 68	ENERGOL HP 68 OR CS 68	VITREA 68	VACTRA OIL HEAVY MEDIUM	ESSTIC 50	SERVICE 51	URSA P20
L.6.	SPHEEROL AP 3	ENERGREASE LS 3	ALVANIA GREASE NO.3	MOBILPLEX GREASE NO.48	BEACON 3	GULFCROWN GREASE NO.3	REGAL STARTAK PREMIUM 3

- L.1. OIL Hydraulic oil with anti-corrosion, anti-oxidation, anti-wear, anti-foam performance.
- L.2. OIL Gear oil (Viscosity 150 centi-stokes at 40°C.)
- L.4. OIL Plain mineral oil (Viscosity 68 centi-stokes at 40°C.)
- L.6. GREASE Grease NLGI NO.3. consistency Lithium bearing grease.

4.2.1 Changing the Bearing of the Cutterblock Spindle.

The bearings have been fitted to the cutterblock spindles (2) in an orthodox manner, however at the non-drive end of the spindle a liquid engineering adhesive "LOCTITE" Grade 241 has been applied to the internal diameter of the bearing nut (3).

NOTE:- This can be either a left hand OR right hand thread dependent upon the spindle location.

To disassemble the parts jointed by "LOCTITE" no special tools are necessary, use normal tools and methods. If, however, the holding force of the "LOCTITE" joint is too great then apply a gentle heat and break the bond whilst the parts are still hot, sometimes the bond is left as a powder. This powder must be removed before applying further adhesive.

PREPARATION PRIOR TO FITTING THE BEARINGS.

Before fitting the new bearing the protective lubricant must be meticulously removed with petroleum spirit, triethanolamine OR other volatile solution.

In order to prevent the moving parts from being damaged by over cleansing add a small amount of the new lubricant to the cleansing agent at the second bath. The film of grease which remains after the solvent has evaporated will provide a good protection for the bearing.

At this stage the new bearings should be changed with "KLUBER" LUBRICANT TYPE "ISOFLEX" NBU.15. It is very important that the correct amount of grease be applied to the bearing preferably the amount by applying the formula:-

$$G \text{ (weight in grams)} = d \times B \times 0.01.$$

where

d = bore of the bearing in mm.

and

B = width in mm.

OR approximately sufficient to fill one third of the bearing volume.

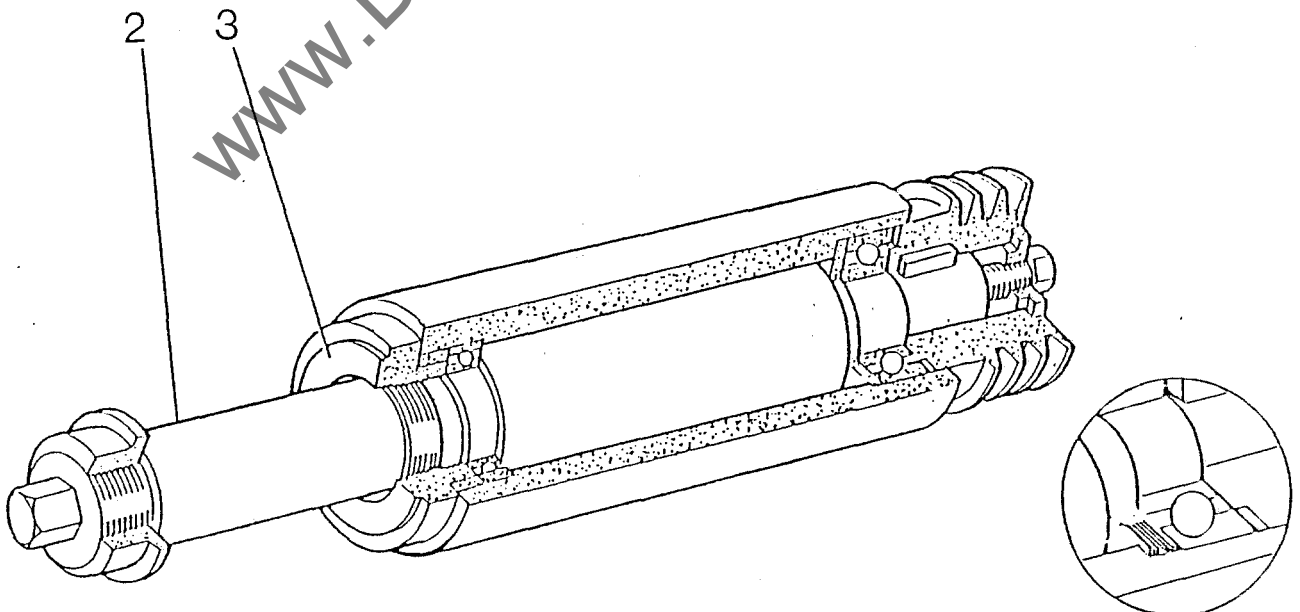

BOTTOM HEAD SPINDLE UNIT 40mm DIAMETER SQUARE SHOULDER

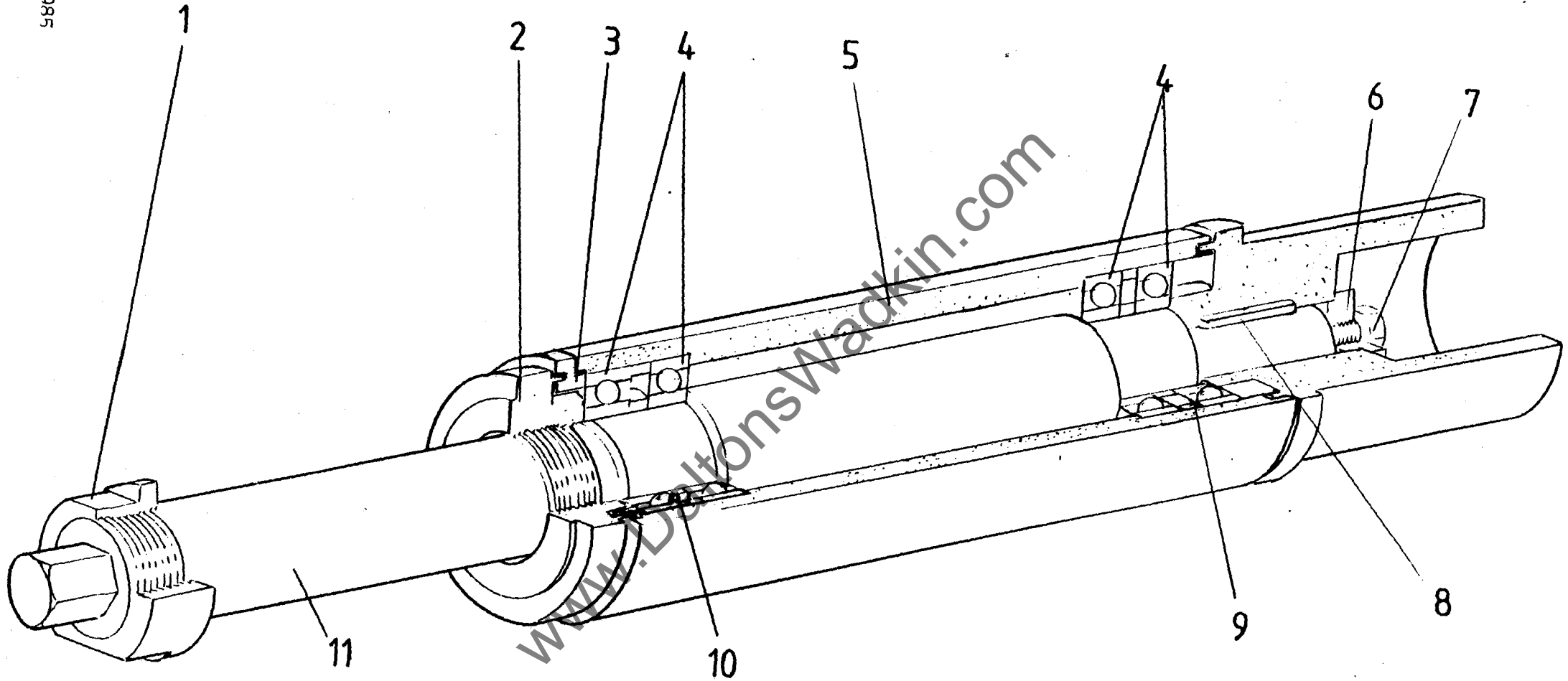

FENCE SIDE HEAD SPINDLE UNIT 40mm DIAMETER SQUARE SHOULDER
WITH PRECISION BEARINGS
1500 RPM.

SEE PAGE 119 FOR INDEX OF COMPONENTS.

REPLACEMENT OF PARTS ASSOCIATED WITH THE MOTOR PULLEYS

- 1) Before access can be made to any belt OR pulley it will be necessary to remove the guard covers.
- 2) Slacken off the tension of motor pulley driving belt. This is effected by loosening the motor fixing bolts on the attendant motor bracket OR the motor tensioner bolts whichever apply. The belts can then be removed.
- 3) The cutterblock spindles are fitted with Vee belt pulleys with keys and the motor shafts are fitted with pulley having taper lock bushes instead of orthodox key.

TO REMOVE THE TAPER LOCK BUSH FROM THE PULLEYS

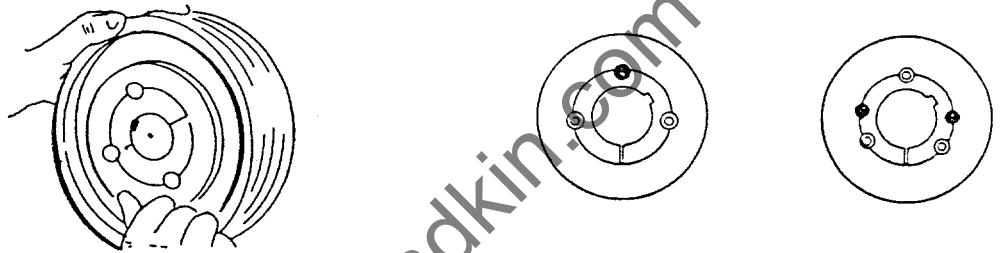

- 1) Slacken all screws by several turns, remove one OR two according to number of jacking off holes shown thus ● in diagram. Insert screws in jacking off holes after oiling thread and point of grub screws OR thread and under head of cap screws.
- 2) Tighten screws alternately until bush is loosened in hub and assembly is free on shaft.
- 3) Remove assembly from shaft.

RE-FITTING THE PULLEYS AND TAPER LOCK BUSHES

- 1) After ensuring that the mating tapered surfaces are completely clean and free from oil OR dirt, insert bush in hub so that holes line up.
- 2) Oil thread and point of grub screws OR thread under head of cap screws. Place screws loosely in holes threaded in hub, shown thus \odot in diagram.

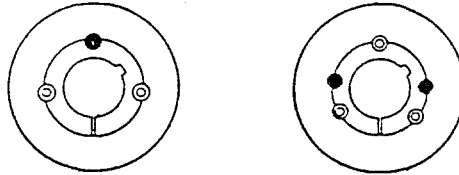

- 3) Clean shaft and fit hub and bush to shaft as one unit and locate in position desired, remembering that bush will nip the shaft first and then hub will be slightly drawn on to the bush.
- 4) Using a hexagon wrench, tighten screws gradually and alternately until all are pulled up very tightly. Use a piece of pipe on wrench to increase leverage.
- 5) After the bush has been tightened on to the shaft fit the parallel key which is side fitting with top clearance.
- 6) After drive has been running under load for a short time, stop and check tightness of screws.
- 7) Fill empty holes with grease to exclude dirt.

IMPORTANT:-

CHECK THE CONDITION AND TENSION OF THE CUTTER SPINDLE
DRIVE BELTS AT REGULAR INTERVALS.

4.4 Maintenance of the Cutters and Tool Holders.

When choosing the cutters make sure that they are suitable for a speed of 6000 rpm. (Dynamically balance and check for defects and cracks). The life of the cutterblock is directly related to the quality of the steel and the nature of the timber to be worked. It is practically impossible to give here the exact values. We can nevertheless quote the following as a guide.

High Speed Steel HLS 2 - 5 hours

Very High Speed Steel HSS 3 - 8 hours

Carbide Steel HM 20 - 70 hours

Circular sawblades chrome vanadium CV 1.5 - 3 hours

Honing at intervals prolongs the life of the cutters. On re-grinding it is very important to ensure that the edge does not become overheated. (If light cuts are taken overheating is prevented.)

Ensure that the knives of the multiple knife cutter are all the same, the knives should always cut the timber evenly.

Treat the circular saws in a similar manner. In many cases where the teeth of the saw are in Chrome Vanadium it will be necessary to carefully swage them. The performance of the tool depends to large extent on the care in the way that it is used. The life of the cutter and the surface finish of the workpiece are directly related to the care which is apportioned to the work.

4.5 Elimination of Vibration during Work.

IMPORTANT:- Check the condition and tension of the cutterspindle drive belts at regular intervals

Adjustment of the Belt.

The belt platforms and the vee belts do not require any particular care.

Observe the operation of the machine when it is first put into service and after one hours effective work tighten the belts. Check the remaining heads at intervals and if the occasion arises tighten the belts. Insufficient tightening (tensioning) causes slipping OR premature wear. If one OR more of the vee belts become faulty it will be necessary to change the complete set. During the fitting reduce the belt centres to enable them to be replaced without force.

To retension the belts use spanner (79).

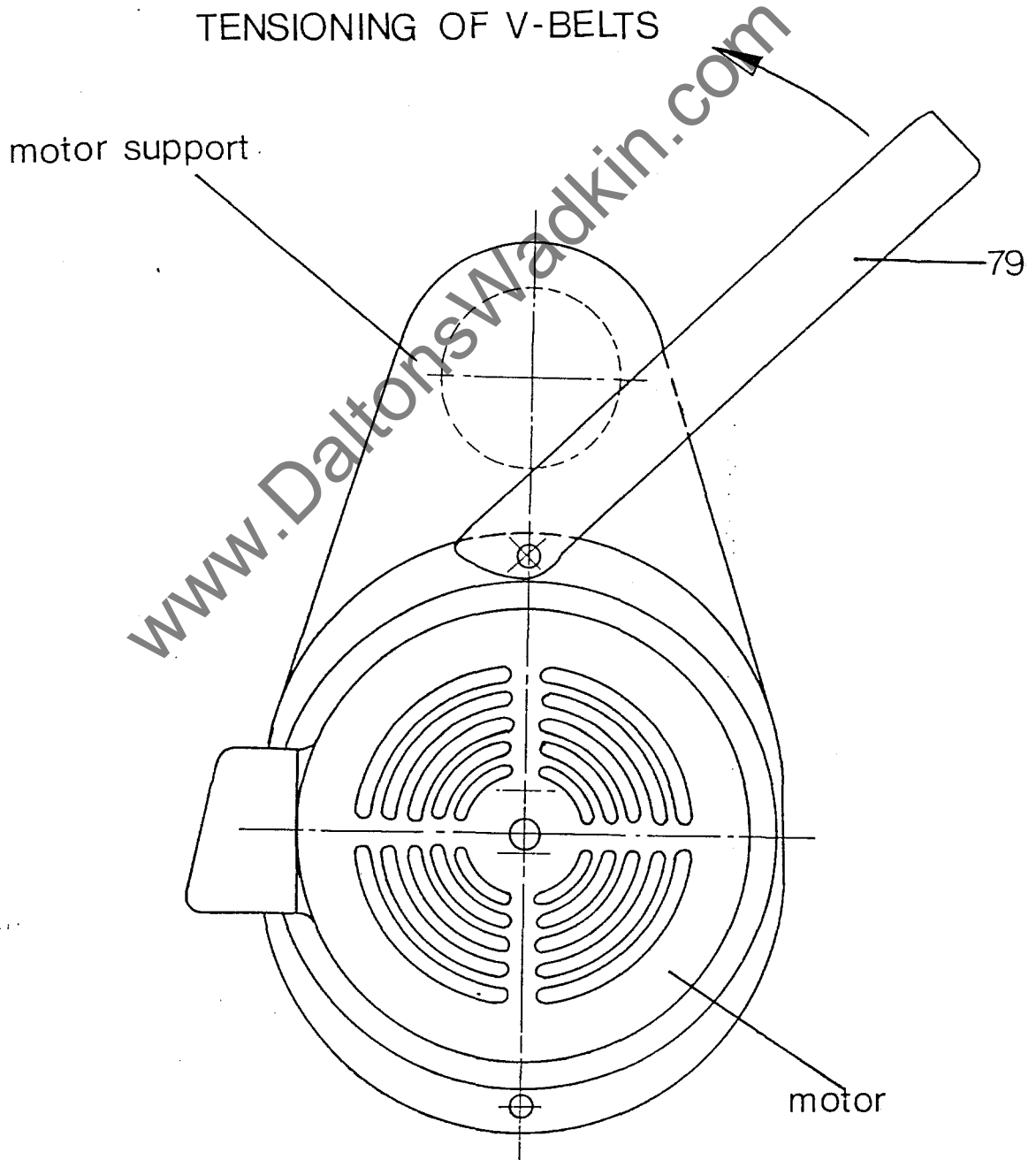

MAINTENANCE OF VARIABLE SPEED PULLEYS

The variable speed pulleys incorporated within the feed roll drive are maintenance free.

Should it be necessary to repair the feed drive proceed as follows:-

4.6 Dismantle.

4.6.1 General dismantling

Adjust the drive unit to the maximum output speed before dismantling.
Switch off drive.

1. Adjustment devices.

Unscrew socket head capscrews (23) and remove complete adjustment devices (21) (24) (25) OR (26).

2. Speed indicator.

Unscrew nut (33) and remove housing (32). Loosen nut (30) and unscrew with stud (31).

4.6.2 Removing wide section vee belt.

Unscrew socket head capscrews (20) and whilst supporting the motor (5) separate cover (18) and connecting casting (2) so that the belt (17) can be removed from the variable speed pulley (13). Remove belt (17) from the variable speed pulley (9).

4.6.3 Dismantling variable speed pulleys, motor and housing.

1. Mechanically adjustable variable speed pulley. Unscrew axial tightening screw (16) and remove end cap (14). The Disc.... See Fig.1. is a tooling aid. Assemble the disc behind the circlip of the pulley, and with an extractor remove the pulley (13) from the motor shaft.

2. Spring loaded variable speed pulley.

Unscrew axial tightening screw (12) OR screw (27) if with speed indicator, and remove end cap (10). With the aid of an extractor, gripping behind the hub flange of the pulley - remove the pulley (9) from the gearbox shaft, firstly remove the spring and spring retaining cap with a tooling aid.... See Fig.2. Then remove the pulley from the gearbox shaft as indicated in 3.1.3 point 1.

3. Motor and housing.

Unscrew hexagon head screw (7) and remove motor. Unscrew hexagon head screw (4) and remove housing.

Size	a	b	d +0.2	d ₁	d ₂
10	12	3	21.1	26	40
13	12	3	28.1	37	50
16	14	3	34.1	42	60
20	20	4	39.1	47	65
25	25	5	50.1	62	80
31	28	5	58.1	72	90

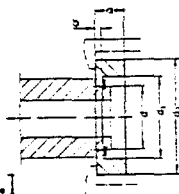

Fig.1

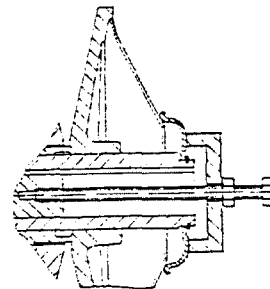

Fig.2

MAINTENANCE CONTD.

4.6.4 Assembly.

The assembly procedure is in the reverse sequence to the dismantling operation. When refitting the wide section vee belt, it must firstly be placed into the fully opened mechanical variable speed pulley (13), and then over the rim of the spring loaded variable speed pulley (9). Only original "SIMPLABELT" wide section vee belts can be used (part of the guarantee conditions).

4.6.5 SPARE PARTS LIST

When ordering spares, all the data shown on the nameplate must be quoted.

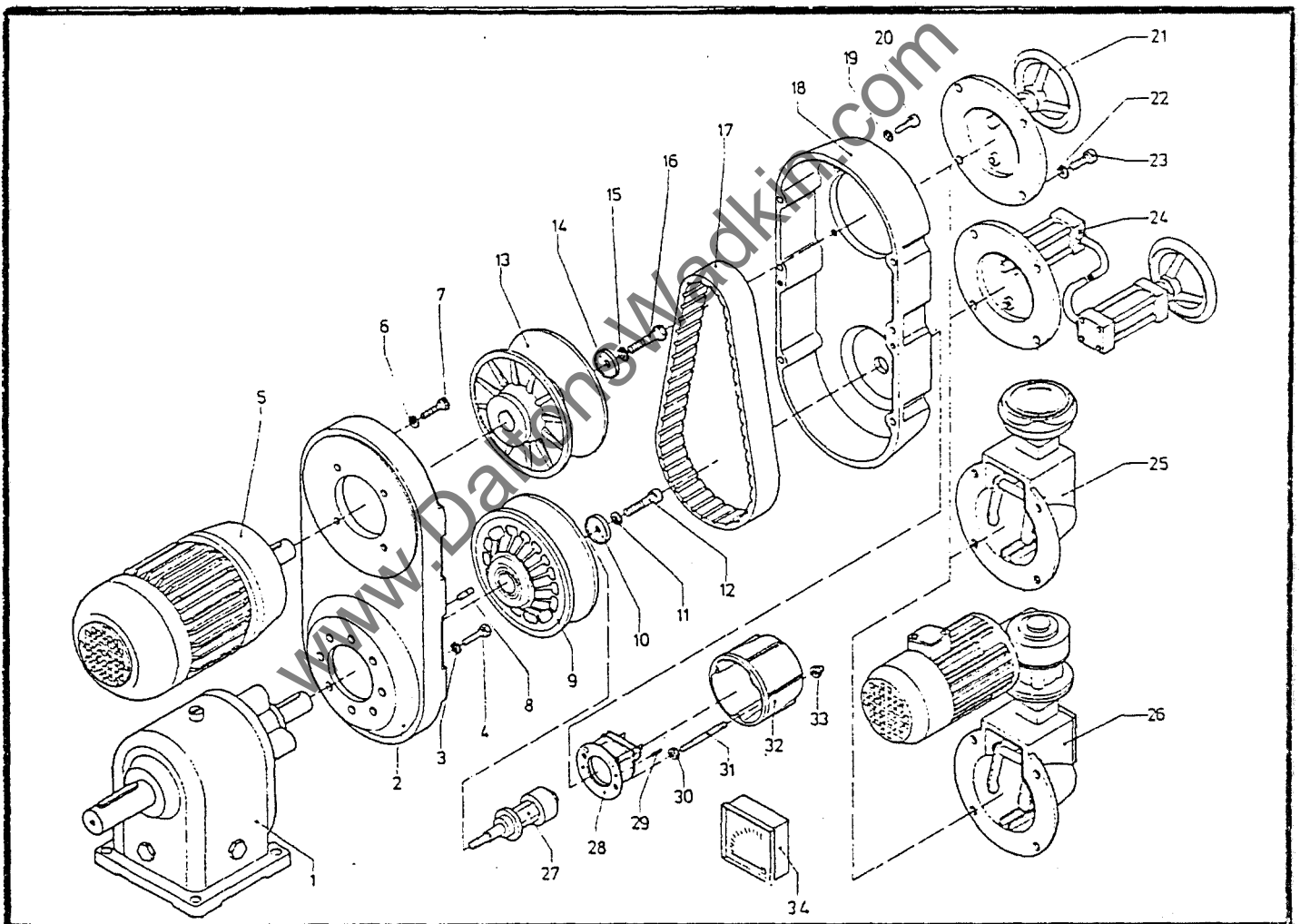

4.7 Electrical Faults.

1. The machine does not run when any "START" button is operated.

Diagnosis

- a Disconnect (isolator) switch has not been closed.
- b Main fuse OR control circuit fuse has blown.
- c Overload relay has tripped.

Remedial Action Check Symptoms a b c

2. A motor does not start - loud humming sound.

Diagnosis

- a An open circuit in at least two "line leads" of the motor.
- b The fuses of the motor has blown.

Remedial Action Check Symptoms a b

3. An air break magnetic contactor does not operate.

Diagnosis

- a The contacts are burned and make improper contact.
- b Broken connection wire.
- c An overload relay has tripped.
- d A fuse has blown.

Remedial Action Check Symptoms a b c d

4. A Star/Delta connected motor does not operate when the contactor is connected in star.

Check all the symptoms as outlined in Paragraph 3.

5. When a motor is started, the fuses blow and the overload relay trips.

Diagnosis

- a The motor does not run.
- b There is a short circuit in the wiring to the mains
- c The motor windings OR winding is earthed.

Remedial Action.

Check that the motor is free running.

Check the wiring.

Check the windings in turn for electrical continuity and also for earth faults with a "Megger".

4.7 Electrical Faults.....contd

6. The Motor overheats when running "Light" (unloaded)

Diagnosis

- a The motor windings are connected in delta instead of star.
- b The mains voltage is too high.
- c The ventilating cooling ducts of the motor frame have become blocked with wood chips, OR the cooling air passage has become impeded OR cooling fan (if fitted) is not functioning correctly.

Remedial Action Check Symptoms a b c

7. Motor overheats whilst working.

Diagnosis

- a The motor is overloading.
- b The motor is running under single phase conditions.

Remedial Action Check the line current and the wiring.

8. The motor makes an abnormal noise.

Diagnosis

- a The cause could either be of a mechanical OR electrical nature.
- b If the noise is caused by an electrical fault the noise will disappear on being switched off.
- c If the noise is caused by a mechanical fault the noise will diminish as the speed of rotation decreases.

9. The Air break magnetic starter is noisy.

Diagnosis

- a The mains voltage is too low.
- b The surfaces of the "fixed" and "moving" contacts are dirty.

Remedial Action Check Symptoms a b

10. The Air break magnetic starter remains "closed" after "STOP" button has been operated.

Diagnosis

- a The "fixed" and "moving" contacts have welded together following a short circuit.

Remedial Action: Remove the cause of the short circuit and replace the damaged contacts - however if the contacts are too damaged it may be necessary to replace the complete contactor.

4.7 Electrical faults.....contd.

11. If a fault condition arises on a motor and the overload current relay fails to operate.

Diagnosis

- a The overload relay may be incorrectly rated - it should correspond to the normal full load current of the motor (given on a motor nameplate) for Direct-on-Line starting.
- b If the overload relay is connected in a Star/Delta starter, the rating of the overload should be the normal full load current of the motor (given on the motor nameplate) multiplied by 1.1/73 (0.58).

12. A spindle motor stops - but the spindle continues to run.

Diagnosis

- a The belts are too loose.
- b Two OR three fuses have blown.

A spindle stops but the motor still runs.

Diagnosis

- c The overload relay fails to operate

Remedial Action - tighten the belts and check fuses.

13. The Rise and Fall motor does not operate.

Diagnosis

- a The limit switch on the Top Horizontal Head OR the limit switch at the end of the machine is jammed by wood chips OR are damaged.
- b The push button is faulty.

Remedial Action - Check and clean the limit switches.
- Check and change the push button.

14. If the limit switch between the Top head and the beam is operated simultaneously with either of the two beam vertical traverse limit switches, the beam will not lower.

Diagnosis

- a Disengage the clutch on top head and wind down the top head until limit switch is released - then bring beam down by normal procedure - (push button).

The foregoing observations are of a general nature and intended to be of assistance to avoid the incidence of breakdown, it does not preclude the user in call a qualified electrician in cases of electrical breakdowns.

BELTS AND PULLEYS FOR SPINDLE DRIVE TO

FIRST BOTTOM HEAD

FREQUENCY 50 HERTZ

MOTOR.			MOTOR PULLEY.		TAPER LOCK BUSH.			BELTS.			SPINDLE PULLEY.	SPINDLE SPEED.
SIZE	K.W.	H.P.	FENNER REF.	WADKIN CODE.	BORE. M.M.	FENNER REF.	WADKIN CODE.	FENNER REF.	WADKIN CODE.	QUAN.	WADKIN NUMBER.	R.P.M.
D112	4.0	5.5	031Z 0222	K30 78 237	28	2012	K30 77 114	SPZ 850	K30 78 213	2	GA 109	6000
D132	5.5	7.5)	031Z 0223	K30 78 218	38	2012	K30 77 113	SPZ 850	K30 78 213	3	GA 410	6000
	7.5	10.0)										
	11.0	15.0)										
D160	15.0	20.0	031Z 0224	K30 78 209	42	251	K30 77 101	SPZ 850	K30 78 213	4	GA 755	6000
D112	4.0	5.5	031Z 0262	K30 78 238	28	2012	K30 77 114	SPZ 900	K30 78 351	2	GA 109	7500
D132	5.5	7.5)	031Z 0263	K30 78 244	38	2012	K30 77 113	SPZ 900	K30 78 351	3	GA 410	7500
	7.5	10.0)										
	11.0	15.0)										

BELTS AND PULLEYS FOR SPINDLE DRIVE TO

FIRST FENCE SIDE HEAD

FREQUENCY 50 HERTZ

MOTOR.			MOTOR PULLEY.		TAPER LOCK BUSH.			BELTS.			SPINDLE PULLEY.	SPINDLE SPEED.
SIZE	K.W.	H.P.	FENNER REF.	WADKIN CODE.	BORE. M.M.	FENNER REF.	WADKIN CODE.	STEPHENS REF.	WADKIN CODE.	QUAN.	WADKIN NUMBER.	R.P.M.
D112	4.0	5.5		GA 415				METEOR CE 3P	K30 05 383	1	GA 413	6000
D132	5.5 7.5 11.0	7.5) 10.0) 15.0)		GA 416				METEOR CE 6P	K30 05 384	1		6000
D112	4.0	5.5		GA 1338				METEOR CE 6P	K30 05 376	1		7500
D132	5.5 7.5 11.0	7.5) 10.0) 15.0)		GA 1298				METEOR CE 6P	K30 05 366	1		7500
D112	4.0	5.5		GA 1535				METEOR CE 6P	K30 05 376	1		9000
D132	5.5 7.5 11.0	7.5) 10.0) 15.0)		GA 1498				METEOR CE 6P	K30 05 375	1	GA 1497	9000

BELTS AND PULLEYS FOR SPINDLE DRIVE TO

NEAR SIDE HEAD

FREQUENCY 50 HERTZ

MOTOR.			MOTOR PULLEY.		TAPER LOCK BUSH.			BELTS.			SPINDLE PULLEY.	SPINDLE SPEED.
SIZE	K.W.	H.P.	FENNER REF.	WADKIN CODE.	BORE. M.M.	FENNER REF.	WADKIN CODE.	STEPHENS REF.	WADKIN CODE.	QUAN.	WADKIN NUMBER.	R.P.M.
D112	4.0	5.5		GA 415				METEOR CE 3P	K30 05 387		GA 413	6000
D132	5.5 7.5 11.0	7.5) 10.0) 15.0)		GA 416				METEOR CE 6P	K30 05 388			6000
D112	4.0	5.5		GA 1338				METEOR CE 3P	K30 05 387			7500
D132	5.5) 7.5) 11.0)	7.5) 10.0) 15.0)		GA 1298				METEOR CE 6P	K30 05 367			7500
D112	4.0	5.5.		GA 1535				METEOR CE 6P	K30 05 413			9000
D132	5.5 7.5 11.0	7.5) 10.0) 15.0)		GA 1498				METEOR CE 6P	K30 05 418		GA 1497	9000

BELTS AND PULLEYS FOR SPINDLE DRIVE TO

SECOND FENCE SIDE HEAD

FREQUENCY 50 HERTZ

MOTOR.			MOTOR PULLEY.		TAPER LOCK BUSH.			BELTS.			SPINDLE PULLEY.	SPINDLE SPEED.
SIZE	K.W.	H.P.	FENNER REF.	WADKIN CODE.	BORE. M.M.	FENNER REF.	WADKIN CODE.	STEPHENS REF.	WADKIN CODE.	QUAN.	WADKIN NUMBER.	R.P.M.
D112	4.0	5.0		GA 415				METEOR CE 3P	K30 05 383	1	GA 413	6000
D132	5.5 7.5 11.0	7.5) 10.0) 15.0)		GA 416				METEOR CE 6P	K30 05 384	1		6000
D112	4.0	5.5		GA 1338					K30 05 376	1		7500
D132	5.5 7.5 11.0	7.5) 10.0) 15.0)		GA 1298				METEOR CE 6P	K30 05 366	1		7500
D112	4.0	5.5		GA 1535				METEOR CE 6P	K30 05 376	1		
D132	5.5 7.5 11.0	7.5) 10.0) 15.0)		GA 1498				METEOR CE 6P	K30 05 375	1	GA 1497	9000

BELTS AND PULLEYS FOR SPINDLE DRIVE TO FIRST TOP HEAD/SECOND BOTTOM HEAD.
ADDITIONAL TOP HEAD/ADDITIONAL BOTTOM HEAD. FREQUENCY 50 HERTZ

MOTOR.			MOTOR PULLEY.		TAPER LOCK BUSH.			BELTS.			SPINDLE PULLEY.	SPINDLE SPEED.
SIZE	K.W.	H.P.	FENNER REF.	WADKIN CODE.	BORE. M.M.	FENNER REF.	WADKIN CODE.	FENNER REF.	WADKIN CODE.	QUAN.	WADKIN NUMBER.	R.P.M.
D112	4.0	5.5	031Z 0222	K30 78 237	28	2012	K30 77 114	SPZ 850	K30 78 213	2	GA 109	6000
D132	5.5 7.5 11.0	7.5) 10.0) 15.0)	031Z 0223	K30 78 218	38	2012	K30 77 113	SPZ 850	K30 78 213	3	GA 410	6000
D160	15.0	20.0	031Z 0224	K30 78 209	42	2517	K30 77 101	SPZ 850	K30 78 213	4	GA 755	6000
D112	4.0	5.5		K30 78 238	28	2012	K30 77 114	SPZ 900	K30 78 351	2	GA 109	7500
D132	5.5 7.5 11.0	7.5) 10.0) 15.0)		K30 78 244	38	2012	K30 77 113	SPZ 900	K30 78 351	3	GA 410	7500
D160	15.0	20.0									GA 755	7500
D112	4.0	5.5		K30 78 241	28	2012	K30 77 114	SPZ 1010	K30 77 115	2		9000
D132	5.5 7.5 11.0	7.5) 10.0) 15.0)		K30 78 245	38	2012	K30 77 113	SPZ 1010	K30 77 115	3	GA 1475	9000
D160	15.0	20.0		K30 78 225	42	2517	K30 77 101	SPZ 1010	K30 77 115	4	GA 1514	9000

BELTS AND PULLEYS FOR SPINDLE DRIVE TO

UNIVERSAL HEAD.

FREQUENCY 50 HERTZ

MOTOR.			MOTOR PULLEY.		TAPER LOCK BUSH.			BELTS.			SPINDLE PULLEY.	SPINDLE SPEED.											
SIZE	K.W.	H.P.	FENNER REF.	WADKIN CODE.	BORE. M.M.	FENNER REF.	WADKIN CODE.	FENNER REF.	WADKIN CODE.	QUAN.	WADKIN NUMBER.	R.P.M.											
D112	4.0	5.5	031Z 0222	K30 78 237	28	2012		SPZ 940	K30 77 156	2	GA 109	6000											
D132	5.5	7.5)	031Z 0223	K30 78 218	38	2012		SPZ 940	K30 77 156	3	GA 410	6000											
	7.5	10.0)																					
	11.0	15.0)																					
D160	15.0	20.0	031Z 0224	K30 78 209	42	2517		SPZ 940	K30 77 156	4	GA 755	6000											
D112	4.0	5.5		K30 78 238	28	2012		SPZ 1000	K30 78 435	2	GA 109	7500											
													D132	5.5	7.5)	K30 78 244	38	2012	SPZ 1000	K30 78 435	3	GA 410	7500
														7.5	10.0)								
11.0	15.0)																						
D160	15.0	20.0									GA 755	7500											
D112	4.0	5.5		K30 78 241	28	2012						9000											
													D132	5.5	7.5)	K30 78 245	38	2012				GA 1475	9000
														7.5	10.0)								
11.0	15.0)																						
D160	15.0	20.0		K30 78 225	42	2517					GA 1514	9000											
D112	4.0	5.5						SPZ 900	K30 78 351	2	GA 109	4500											
D132	5.5	7.5)	031Z 0183	K30 77 139	38	2012	K30 77 113	SPZ 900	K30 78 341	3	GA 109	4500											
	7.5	10.0)																					
	11.0	15.0)																					

BELTS AND PULLEYS FOR SPINDLE DRIVE TO

FIRST BOTTOM HEAD

FREQUENCY 60 HERTZ

MOTOR.			MOTOR PULLEY.		TAPER LOCK BUSH.			BELTS.			SPINDLE PULLEY.	SPINDLE SPEED.
SIZE	K.W.	H.P.	FENNER REF.	WADKIN CODE.	BORE. M.M.	FENNER REF.	WADKIN CODE.	FENNER REF.	WADKIN CODE.	QUAN.	WADKIN NUMBER.	R.P.M.
D112	4.0	5.5	031Z 0202	K30 78 294	28	1610	K30 77 184	SPZ 800	K30 78 208	2	GA 109	6000
D132	5.5 7.5 11.0	7.5) 10.0) 15.0)	031Z 0203	K30 78 272	38	2012	K30 77 113	SPZ 800	K30 78 208	3	GA 410	6000
D160	15.0	20.0		K30 77 289	42	2517	K30 77 101	SPZ 800	K30 78 208	4	GA 755	6000
D112	4.0	5.5	031Z 0243	K30 78 499	28	2012	K30 77 114	SPZ 900	K30 78 351	2	GA 1494	7500
D132	5.5 7.5 11.0	7.5) 10.0) 15.0)	031Z 0243	K30 78 499	38	2012	K30 77 113	SPZ 900	K30 78 351	3	GA 1494	7500

BELTS AND PULLEYS FOR SPINDLE DRIVE TO

FIRST FENCE SIDE HEAD

FREQUENCY 60 HERTZ

MOTOR.			MOTOR PULLEY.		TAPER LOCK BUSH.			BELTS.			SPINDLE PULLEY.	SPINDLE SPEED.
SIZE	K.W.	H.P.	FENNER REF.	WADKIN CODE.	BORE. M.M.	FENNER REF.	WADKIN CODE.	STEPHENS REF.	WADKIN CODE.	QUAN.	WADKIN NUMBER.	R.P.M.
D112	4.0	5.5		GA 415				METEOR CE 6P	K30 05 384	1	GA 414	6000
D132	5.5 7.5 11.0	7.5) 10.0) 15.0)		GA 416				METEOR CE 6P	K30 05 385			6000
D112	4.0	5.5		GA 1450				METEOR CE 3P	K30 05 383		GA 1452	7500
D132	5.5 7.5 11.0	7.5) 10.0) 15.0)		GA 1451				METEOR CE 6P	K30 05 385			7500
D112	4.0	5.5		GA 1338				METEOR CE 6P	K30 05 376			9000
D132	5.5 7.5 11.0	7.5) 10.0) 15.0)		GA 1298				METEOR CE 6P	K30 05 366		GA 1483	9000

BELTS AND PULLEYS FOR SPINDLE DRIVE TO

NEAR SIDE HEAD

FREQUENCY 60 HERTZ

MOTOR.			MOTOR PULLEY.		TAPER LOCK BUSH.			BELTS.			SPINDLE PULLEY.	SPINDLE SPEED.
SIZE	K.W.	H.P.	FENNER REF.	WADKIN CODE.	BORE. M.M.	FENNER REF.	WADKIN CODE.	STEPHENS REF.	WADKIN CODE.	QUAN.	WADKIN NUMBER.	R.P.M.
D112	4.0	5.5		GA 415				METEOR CE 3P	K30 05 387		GA 414	6000
D132	5.5 7.5 11.0	7.5) 10.0) 15.0)		GA 416				METEOR CE 6P	K30 05 389			6000
D112	4.0	5.5		GA 1450							GA 1452	7500
D132	5.5 7.5 11.0	7.5) 10.0) 15.0)		GA 1451								7500
D112	4.0	5.5		GA 1338								9000
D132	5.5 7.5 11.0	7.5) 10.0) 15.0)		GA 1298				METEOR CE 6P	K30.05.367		GA 1483	9000

BELTS AND PULLEYS FOR SPINDLE DRIVE TO

SECOND FENCE SIDE HEAD

FREQUENCY 60 HERTZ

MOTOR.			MOTOR PULLEY.		TAPER LOCK BUSH.			BELTS.			SPINDLE PULLEY.	SPINDLE SPEED.
SIZE	K.W.	H.P.	FENNER REF.	WADKIN CODE.	BORE. M.M.	FENNER REF.	WADKIN CODE.	STEPHENS REF.	WADKIN CODE.	QUAN.	WADKIN NUMBER.	R.P.M.
D112	4.0	5.5		GA 415				METEOR CE 6P	K30 05 384	1	GA 414	6000
D132	5.5 7.5 11.0	7.5) 10.0) 15.0)		GA 416				METEOR CE 6P	K30 05 385	1		6000
D112	4.0	5.5		GA 1450				METEOR CE 3P	K30 05 383	1	GA 1452	7500
D132	5.5 7.5 11.0	7.5) 10.0) 15.0)		GA 1451				METEOR CE 6P	K30 05 385	1		7500
D112	4.0	5.5		GA 1338					K30 05 376	1		9000
D132	5.5 7.5 11.0	7.5) 10.0) 15.0)		GA 1298				METEOR CE 6P	K30 05 366	1	GA 1483	9000

FIRST TOP HEAD/SECOND BOTTOM HEAD
 BELTS AND PULLEYS FOR SPINDLE DRIVE TO ADDITIONAL TOP HEAD/ADDITIONAL BOTTOM HEAD. FREQUENCY 60 HERTZ

MOTOR.			MOTOR PULLEY.		TAPER LOCK BUSH.			BELTS.			SPINDLE PULLEY.	SPINDLE SPEED.
SIZE	K.W.	H.P.	FENNER REF.	WADKIN CODE.	BORE. M.M.	FENNER REF.	WADKIN CODE.	FENNER REF.	WADKIN CODE.	QUAN.	WADKIN NUMBER.	R.P.M.
D112	4.0	5.5	031Z 0202	K30 78 294	28	1610	K30 77 184	SPZ 800	K30 78 208	2	GA 109	6000
D132	5.5 7.5 11.0	7.5) 10.0) 15.0)	031Z 0203	K30 78 272	38	2012	K30 77 113	SPZ 800	K30 78 208	3	GA 410	6000
D160	15.0	20.0		K30 77 289	42	2517	K30 77 101	SPZ 800	K30 78 208	4	GA 755	6000
D112	4.0	5.5	031Z 0243	K30 78 499	28	2012	K30 77 114	SPZ 900	K30 78 351	2	GA 1494	7500
D132	5.5 7.5 11.0	7.5) 10.0) 15.0)	031Z 0243	K30 78 499	38	2012	K30 77 113	SPZ 900	K30 78 351	3	GA 1494	7500
D160	15.0	20.0										7500
D112	4.0	5.5		K30 78 238	28	2012	K30 77 114	SPZ 900	K30 78 351	2		9000
D132	5.5 7.5 11.0	7.5) 10.0) 15.0)		K30 78 244	38	2012	K30 77 113	SPZ 900	K30 78 351	3	GA 1475	9000
D160	15.0	20.0									GA 1514	9000

BELTS AND PULLEYS FOR SPINDLE DRIVE TO

UNIVERSAL HEAD

FREQUENCY 60 HERTZ

MOTOR.			MOTOR PULLEY.		TAPER LOCK BUSH.			BELTS.			SPINDLE PULLEY.	SPINDLE SPEED.
SIZE	K.W.	H.P.	FENNER REF.	WADKIN CODE.	BORE. M.M.	FENNER REF.	WADKIN CODE.	FENNER REF.	WADKIN CODE.	QUAN.	WADKIN NUMBER.	R.P.M.
D112	4.0	5.5	031Z 0202	K30 78 294	28	1610	K30 77 184	SPZ 900	K30 78 351	2	GA 109	6000
D132	5.5 7.5 11.0	7.5) 10.0) 15.0)	031Z 0203	K30 78 272	38	2012	K30 77 113	SPZ 900	K30 78 351	3	GA 410	6000
D160	15.0	20.0		K30 77 289	42	2517	K30 77 101	SPZ 900	K30 78 351		GA 755	6000
D112	4.0	5.5	031Z 0243	K30 78 499	28	2012	K30 77 114	SPZ 950			GA 1494	7500
D132	5.5 7.5 11.0	7.5) 10.0) 15.0)	031Z 0243	K30 78 499	38	2012	K30 77 113	SPZ 950	K30 78 500		GA 1494	7500
D160	15.0	20.0										7500
D112	4.0	5.5		K30 78 238	28	2012	K30 77 114					
D132	5.5 7.5 11.0	7.5) 10.0) 15.0)		K30 78 244	38	2012	K30 77 113				GA 1475	9000
D160	15.0	20.0										9000

August, 1984

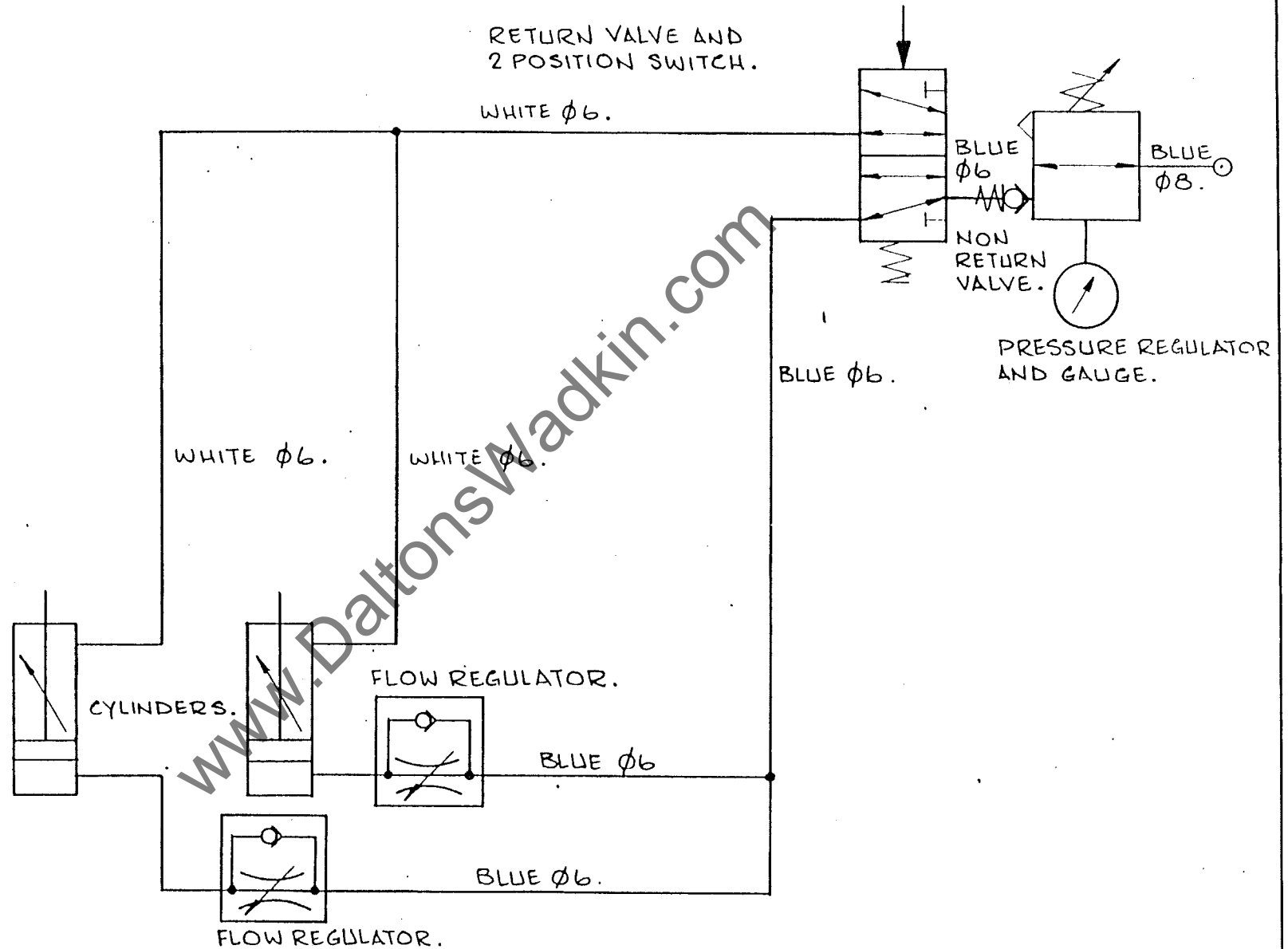

DATE 31 JAN '84	A	WADKIN PLC. LEICESTER (GRP., & WHEN FITTED.). PNEUMATIC CIRCUIT. SOUND ENCLOSURES GA170/220	QTY.	MATERIAL
DRAWN J3C	CHECKED		SCALE	PART No. GA 9090

ALWAYS QUOTE MODEL AND MACHINE NUMBER WHEN ORDERING SPARES

BEDPLATE CHARTS

www.DaltonsWadkin.com

AIR BED

Select the required air bed nozzles at the air bed control unit

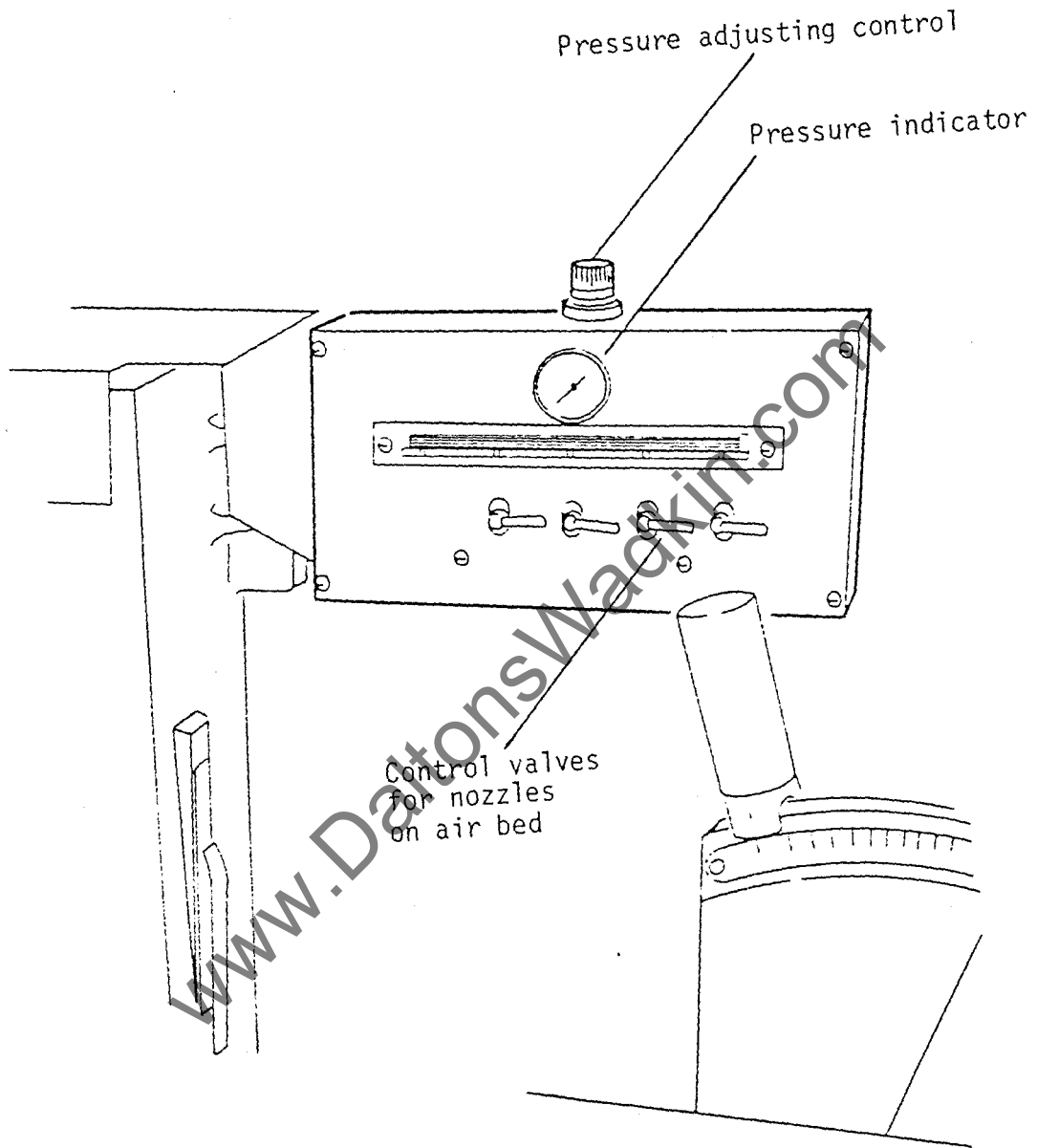

AIR BED CONTROL UNIT (WHERE FITTED)
"170"

July, 1983

NOTE:-

Ø4 YELLOW TUBING (NYLON) FOR FENCE AIR BED
(NEAREST CUTTER ON NEAR SIDE HEAD)

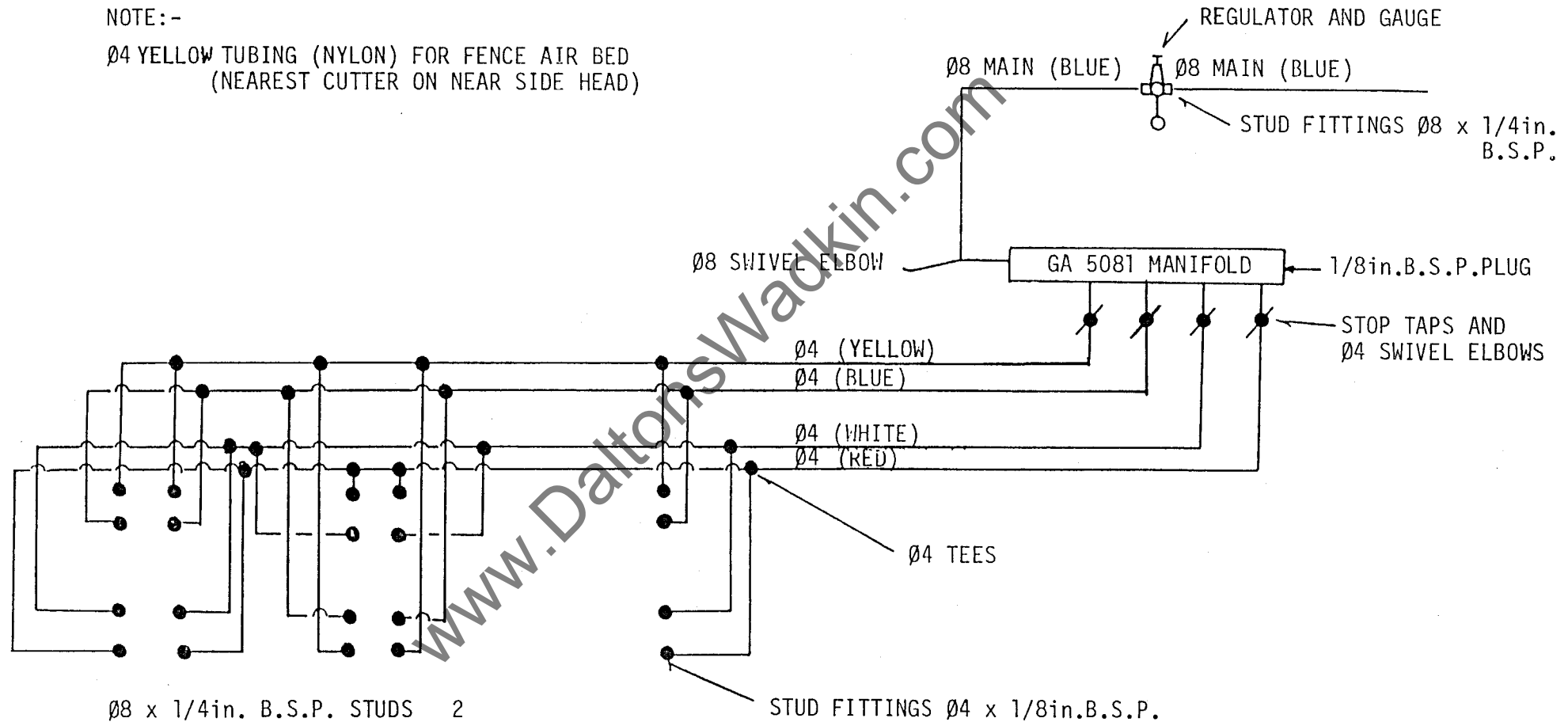

Ø8 x 1/4in. B.S.P. STUDS	2
Ø4 TEES	20
Ø4 x 1/8in. B.S.P. STUD FITTINGS	20
Ø4 x 1/8in. B.S.P. SWIVEL ELBOWS	1
STOP TAPS	5
REGULATOR AND GAUGE ASSEMBLIES	1

Ø8 x 1/8in. B.S.P. SWIVEL ELBOW	1
1/8in. B.S.P. PLUG	1

PNEUMATIC CIRCUIT FOR
AIR BED ON "GA" 170 MACHINE

WHERE FITTED

AIR BED

Select the required air bed nozzles at the air bed control unit

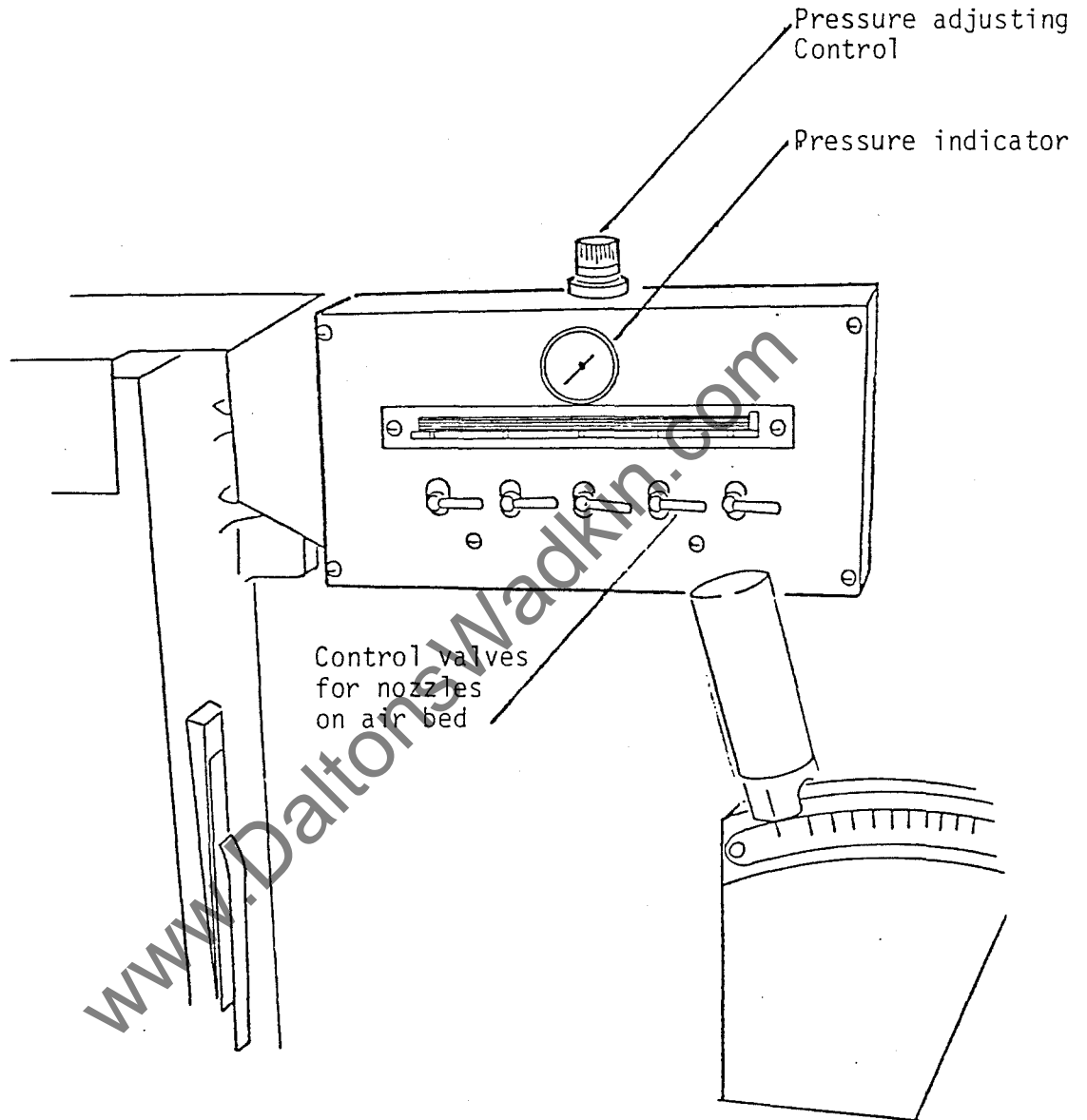

AIR BED CONTROL UNIT (WHERE FITTED)
(220)

July, 1983

NOTE:-

Ø4 GREEN TUBING (NYLON) FOR FENCE AIR BED
(NEAREST CUTTER ON NEAR SIDE HEAD)

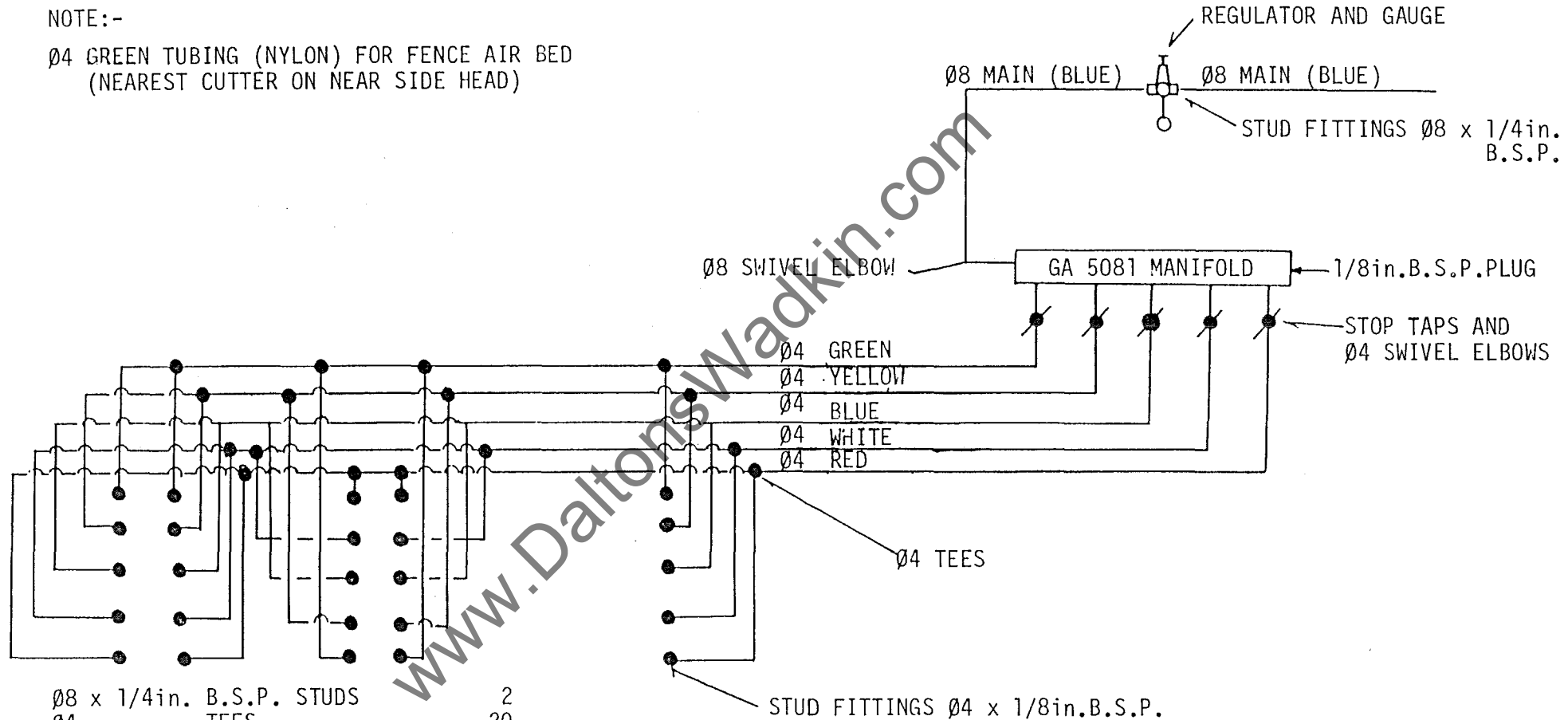

Ø8 x 1/4in. B.S.P. STUDS	2
Ø4 TEES	20
Ø4 x 1/8in. B.S.P. STUD FITTINGS	25
Ø4 x 1/8in. B.S.P. SWIVEL ELBOWS	1
STOP TAPS	5
REGULATOR AND GAUGE ASSEMBLIES	1
Ø8 x 1/8in. B.S.P. SWIVEL ELBOW	1
1/8in. B.S.P. PLUG	1

PNEUMATIC CIRCUIT FOR
AIR BED ON "GA" 220 MACHINE

WHERE FITTED

page 62

ALWAYS QUOTE MODEL AND MACHINE NUMBER WHEN ORDERING SPARES

www.DaltonsWadkin.com

TOP HEAD CHIPBREAKER, PRESSURE AND EXTRACTION HOOD

REF.NO:	DESCRIPTION	NO:OFF
1	M10. x 45mm. long screwed studs	2
2	M10. size bright mild steel washers	2
3	M10. hexagon nuts	2
4	M6. x 35mm. long hexagon socket screws - half dog point	3
5	M6. hexagon nuts	3
6 CA 142	Gib strip for rise and fall bracket Top Head pressure	1
7	Rise and fall slide for shoe, Top Head pressure	1
8	Rise and fall bracket, Top head pressure	1
9	Compression spring for Top pad pressure after Top head.	1
10	Raising screw, Top head pressure	1
11	Top Plate, Top head pressure	1
12	M8. x 20mm. long hexagon socket screws	2
13	No.'0' taper pin	1
14	M12. blind hole stud handwheel	1
15	M12. hexagon thin nuts	2
16	M12. bright mild steel washer	1
17 GA 188/5036	Exhaust hood for Top Head	1
18 KOS25546	M12. x 40mm. long hexagon head screw	1
19 GA 155	Plug for spring loading Top Head chipbreaker	1
20 CA 151	Cap for Top head chipbreaker spring	1
21 GA 154	Spring for Top head chipbreaker	1
22 KOS27103	M10. hexagon nuts	2
23 KOS26267	M10. x 50mm. long screwed studs	2
24 CA 170	Pivot bracket for Top Head chipbreaker	1
25 CA 153	Plunger for spring loading Top head Chipbreaker	1
26 KOS28104	M10. size bright mild steel washers	2
27 KOS23127	6mm. x 6mm. x 32mm. long key	1
28 GA 171	Holder for Top Head chipbreaker shoe	1
29 CA 152	Washer for Top head chipbreaker pivot shaft.	1
30 KOS27147	M12. self locking nut	1
31 GA 145	Pivot shaft for Top head chipbreaker	1
32 CA 374/5040	Shoe for Top head chipbreaker - 70mm. long	1
CA 144/5039	Shoe for Top head chipbreaker - 82mm. long	1
CA 375/6533	Shoe for Top head chipbreaker - 105mm. long	1
33 CA 143	Chip deflector for Top head chipbreaker	1
34	Cross tenon for shoe - Top head pressure	1

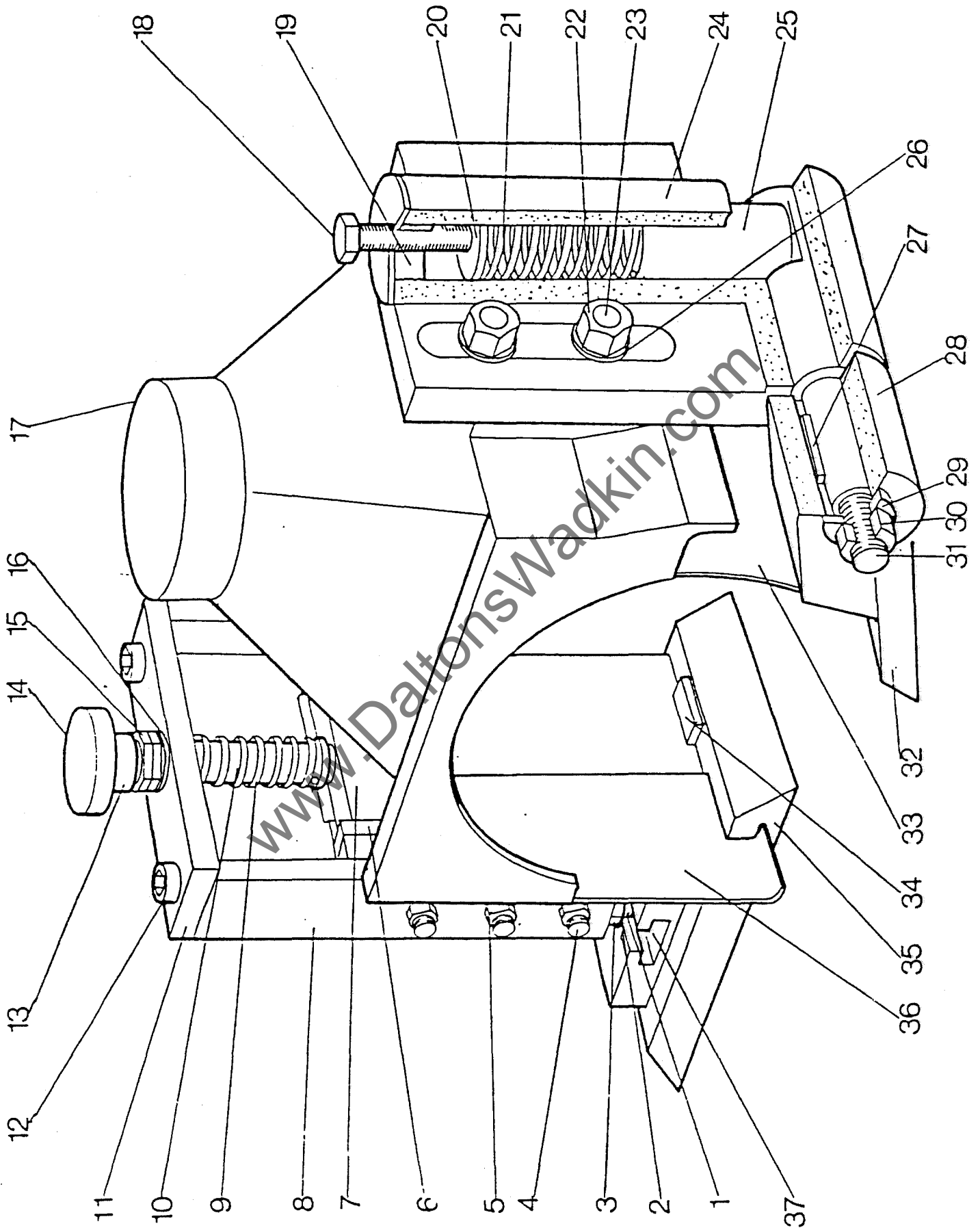

TOP HEAD CHIPBREAKER PRESSIRE & EXTRACTION HOOD

TOP HEAD CHIPBREAKER, PRESSURE AND EXTRACTION HOOD....CONTD

REF.NO:	DESCRIPTION	NO:OFF
35	Shoe Top head pressure	1
36	Cover for Top head pressure	1
37	M10. tee nuts WDS 664 203	2

1 x KO950106 : GREASE NIPPLE

2 x GA 347 : SPRING CLIP

2 x CA 346 : SPACER

2 x GA 345 : SHOULDER PIN

1 x GA 1723 : TOP HOOD FRONT COVER

1 x CA 7796 : GAP FILL RUBBER

2 x KO520520 : 6x16 TENSION PIN

(170) 4 x KO525324 : 6x12 HX SKT CSK SCREW

(220) 4 x KO525731 : 8x60

2 x GA 2147 : RETAINING WASHER

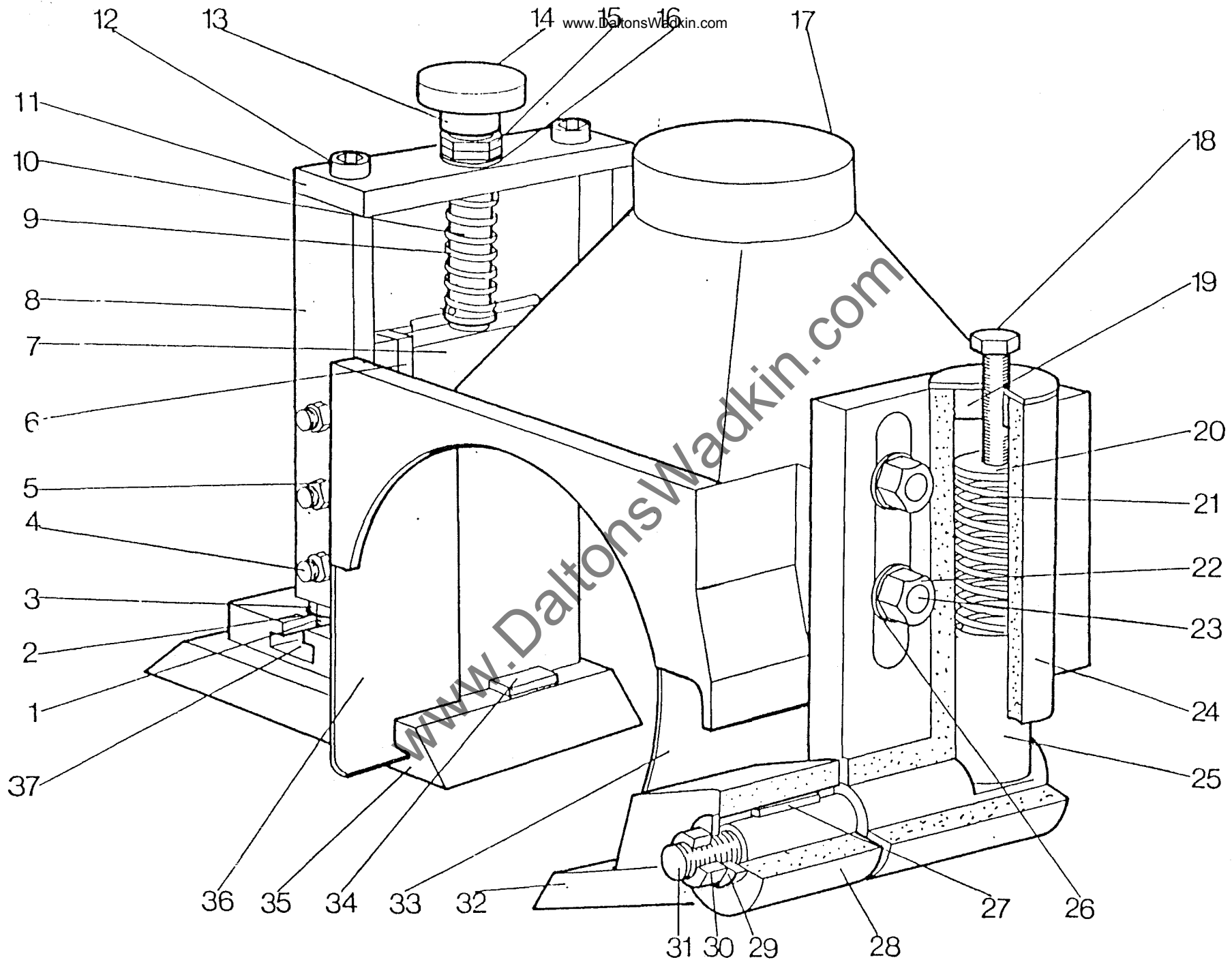

TOP HEAD CHIPBREAKER, PRESSURE & EXTRACTION HOOD

MOUNTING FOR TOP PAD OR ROLLER PRESSURE AFTER TOP HEAD

REF.NO:	DESCRIPTION	NO:OFF
1	Bracket for top pressure	1
2	Horizontal pressure bar for longitudinal adjustment	1
3	Horizontal pressure bar for transverse adjustment	1
4	Split clamp for top pressure horizontal bars	1
5	M10. x 55mm. long stud	1
6	M10. hexagon nut	1
7	M10. size bright mild steel washer	1
8	M10. x 25mm. long hexagon socket screws	2
9	M12. x 40mm. long hexagon head screws	2

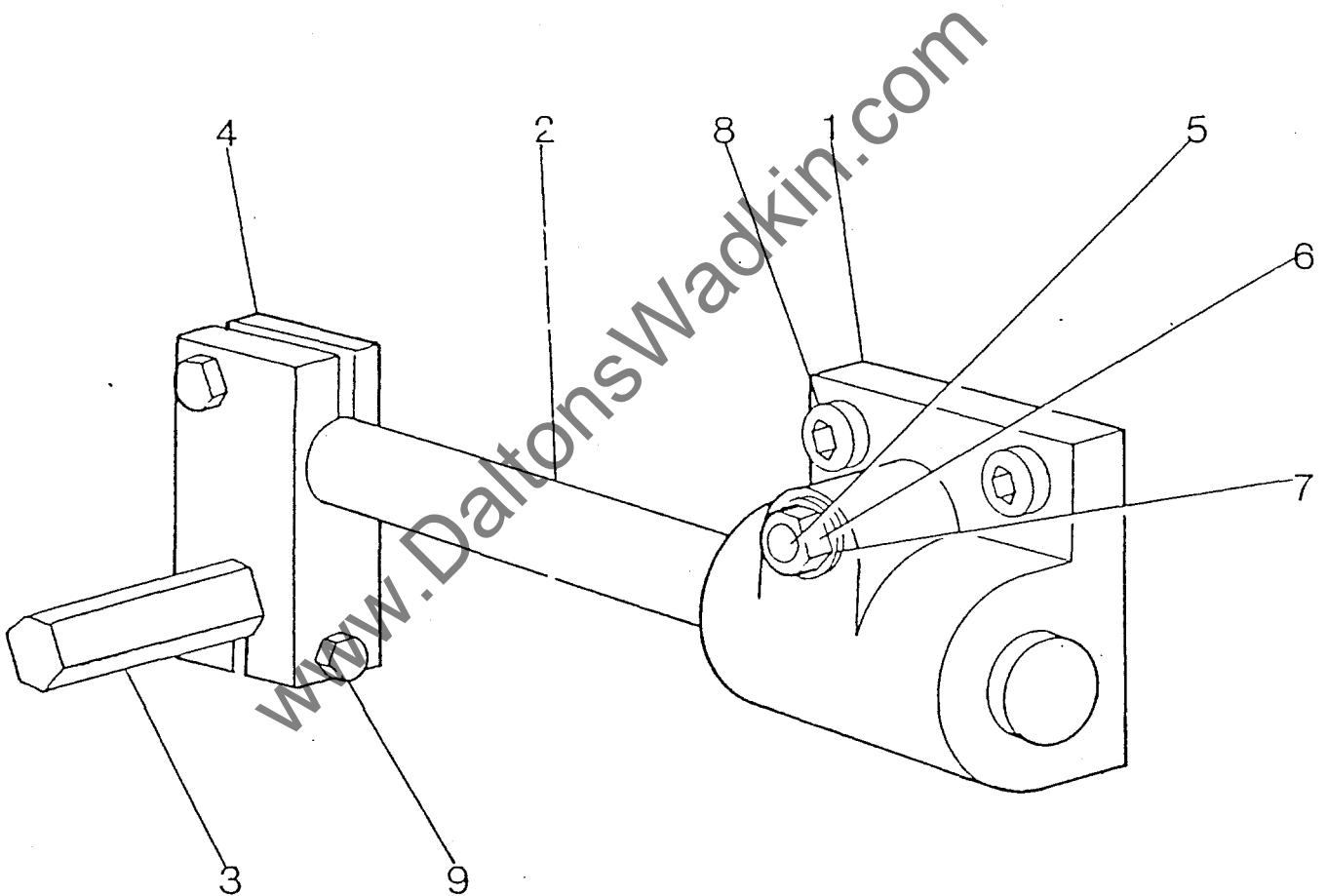

TOP PAD PRESSURE UNIT

REF.NO:	DESCRIPTION	NO:OFF
1	Holder for top pad pressure shoe	1
2	Wooden shoe for top barrel pressure	1
3	Barrel for top pressure	1
4	Spring tensioner for top pressure	1
5	Split clamp for top pressure barrel	1
6	Arm for top pad pressure	1
7	M10. x 30mm. long hexagon head screw:	1
8	M10. hexagon nut	1
9	M10. size bright mild steel washer	1
10	M8. x 35mm. long carriage bolts - including hexagon nuts	2
11	M8. bright mild steel washers	2
12	M12. x 45mm. long hexagon head screws	2
13	8mm. dia. x 24mm. long tension pins	1
14	5mm. dia. x 24mm. long tension pins	1
15	Infeed pressure spring	1

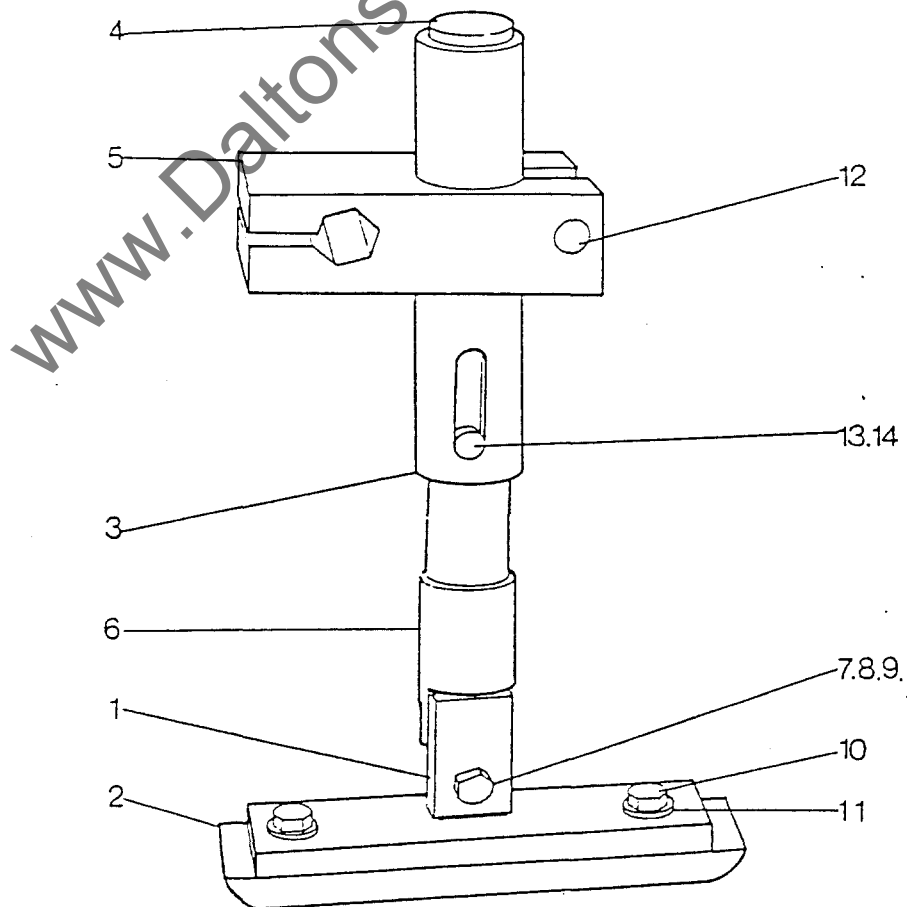

TOP ROLLER PRESSURE UNIT

REF.NO:	DESCRIPTION	NO:OFF
1	Barrel for top pressure	1
2	Spring tensioner for top pressure	1
3	Split clamp for top pressure barrel	1
4	Roller arm for top pressure	1
5	Top pressure roller	1
6	Roller pin for top pressure	1
7	Infeed pressure spring	1
8	8mm. dia. x 24mm. long tension pin	1
9	5mm. dia. x 24mm. long tension pin	1
10	M12. x 45mm. long hexagon head screws	2
11	20mm. external circlip	1
12	SKF. bearing No. 6004 2 RS	1

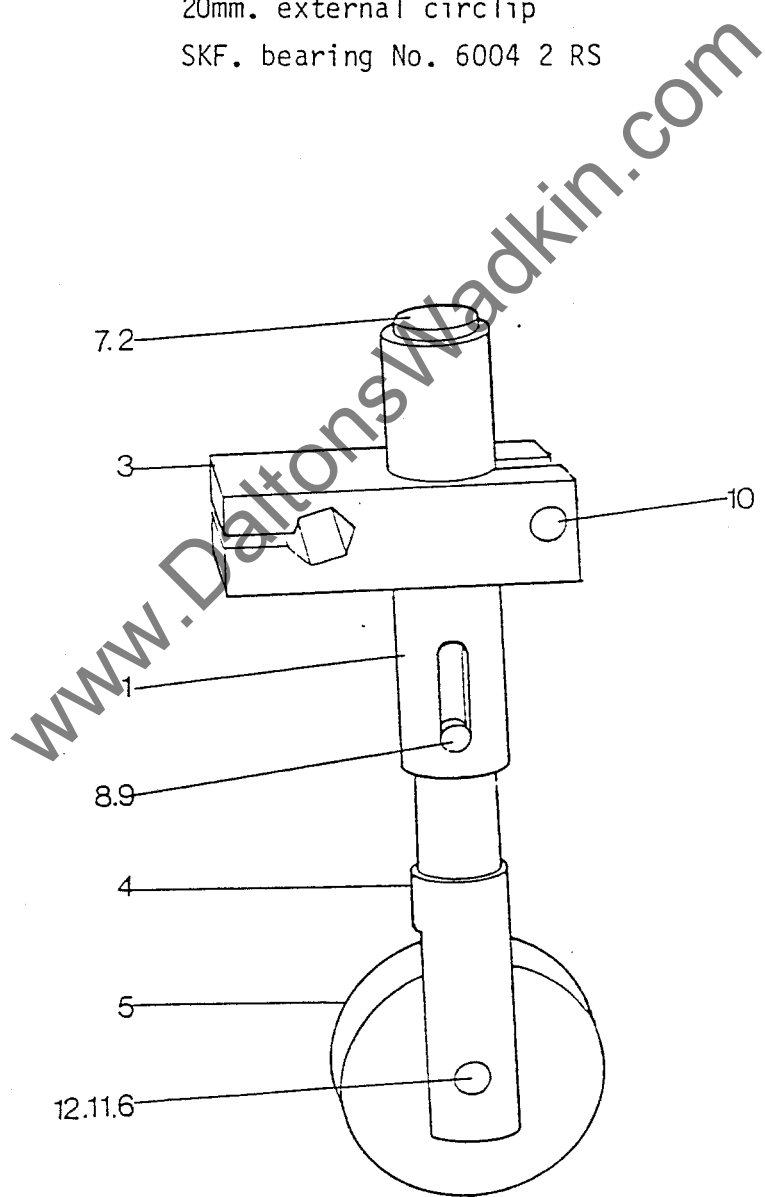

MOUNTING FOR TOP PAD OR ROLLER PRESSURE BEFORE TOP HEAD

REF.NO:	DESCRIPTION	NO:OFF
1	Bracket for top pressure	1
2	Horizontal pressure bar for longitudinal adjustment	1
3	Horizontal pressure bar for transverse adjustment	1
4	Split clamp for top pressure horizontal bars	1
5	M10. x 55mm. long screwed stud	1
6	M10. hexagon nut	1
7	M10. size bright mild steel washer	1
8	M10. x 25mm. long hexagon socket screws	2
9	M12. x 40mm. long hexagon head screws	2

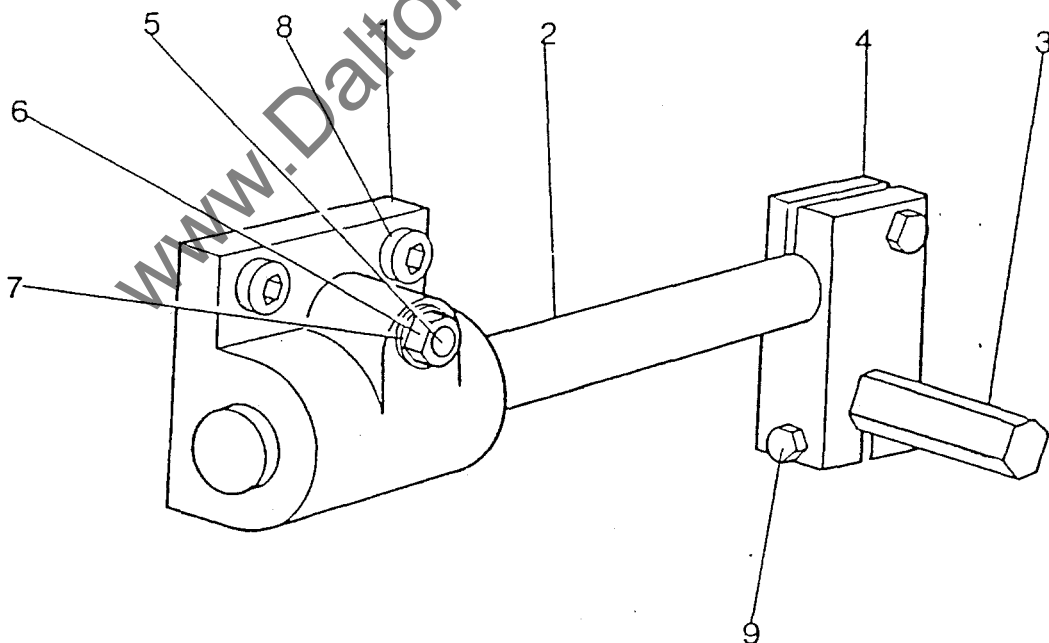

SINGLE SIDE ROLLER PRESSURE OPPOSITE FIRST FENCE SIDE HEAD

REF.NO:	DESCRIPTION	NO:OFF
1	Single roller side pressure bracket	1
2	Roller pin for side pressure	1
3	Pressure roller	1
4	Sliding shaft for pressure roller	1
5	Infeed pressure spring	1
6	M12. x 35mm. long hexagon head screws	2
7	M12. size bright mild steel washers	2
8	8mm. hole size "HEYCO" nylon domed plug - black DP 312	1
9	20mm. external circlip	1
10	SKF bearing 6004 2RS	1
11	8mm. dia. x 30mm. long tension pin	1
12	5mm. dia. x 30mm. long tension pin	1

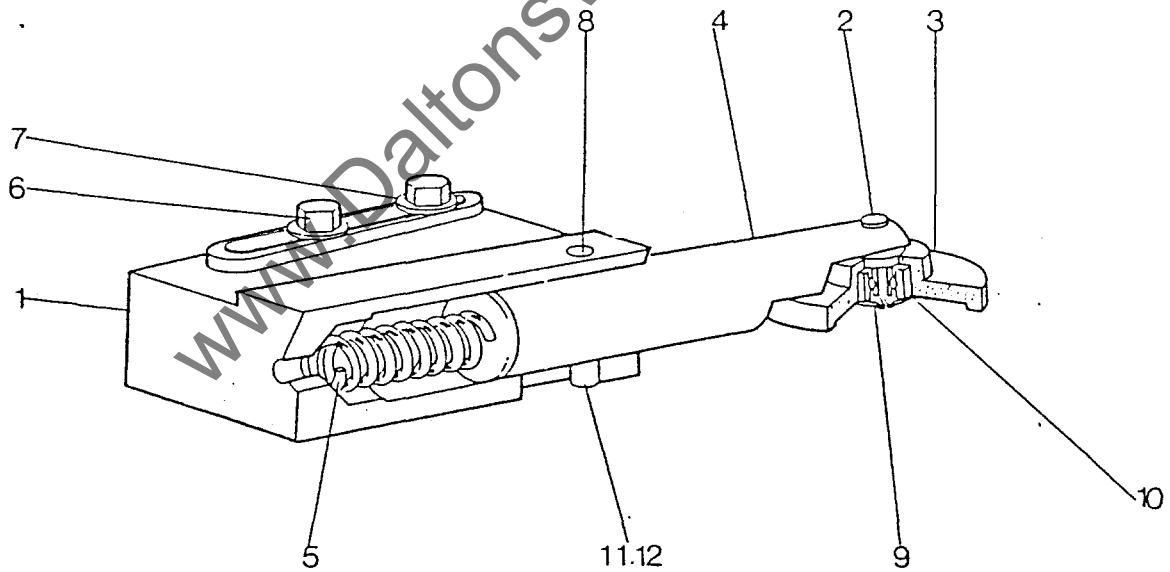

SINGLE SIDE ROLLER PRESSURE BEFORE FIRST BOTTOM HEAD

REF.NO:	DESCRIPTION	NO:OFF
1	Single roller side pressure bracket	1
2	Roller pin for side pressure	1
3	Pressure roller	1
4	Sliding shaft for pressure roller	1
5	Plate to carry single side roller pressure before First Bottom Head	1
6	Infeed pressure spring	1
7	M12. x 35mm. long hexagon screws	2
8	12mm. bore washers	2
9	8mm. hole size "HEYCO" nylon domed plug - black DP 312	1
10	20mm. external circlip	1
11	SKF. bearing 6005 2RS	1
12	8mm. dia. x 30mm. long tension pin	1
13	5mm. dia. x 30mm. long tension pin	1
14	M10. x 25mm. long hexagon socket countersunk head screws	2

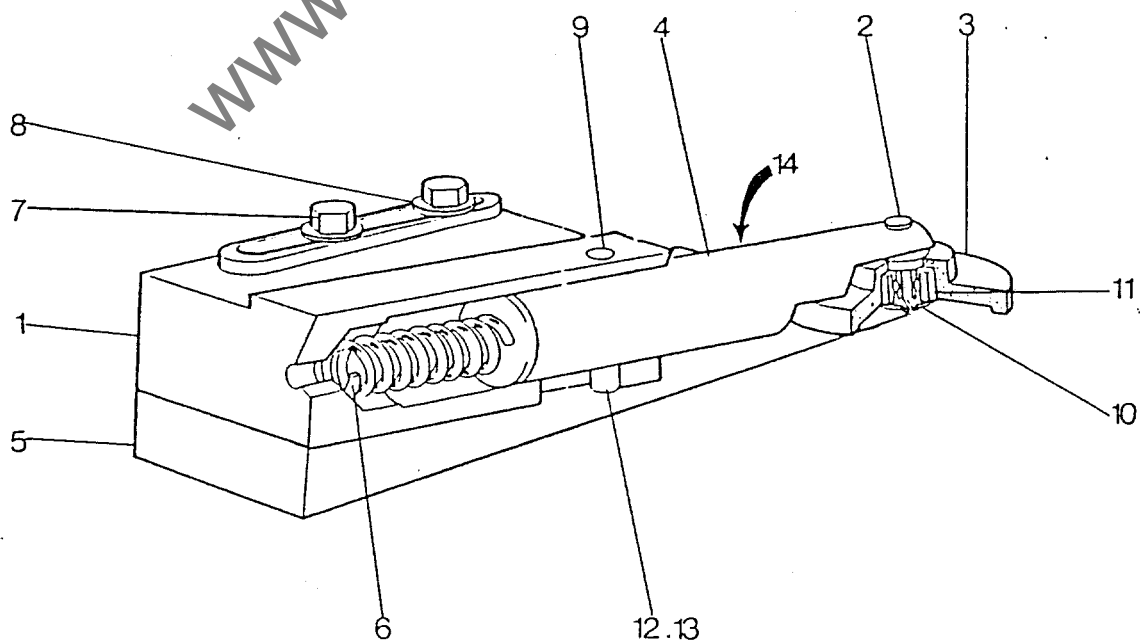

ALWAYS QUOTE MODEL AND MACHINE NUMBER WHEN ORDERING SPARES

www.DaltonsWadkin.com

FEEDROLL UNIT AFTER TOP HEAD OR BETWEEN SECOND BOTTOM HEAD AND UNIVERSAL HEAD
PNEUMATIC OR SPRING LOADED CHAIN DRIVEN.

REF.NO:	DESCRIPTION	NO:OFF
1	30mm. "SEEGER" circlip - external NO: V118	8
2	8mm. x 7mm. x 63mm. long key	1
3	Single lane sprocket for rear chain drive to feed rolls	2
4	"DUPLEX" sprocket for rear chain drive to feed rolls	1
5	Bearing 6206 2RS	2
6	Top intermediate chain drive shaft to feed rolls	1
7	8mm. x 7mm. x 20mm. long key	1
8	Top intermediate sprocket for rear chain drive to feed rolls	1
9	"RENOLD" roller chain NO; 110056 15.88mm. (5/8in.) pitch x 43 pitches	1
	No: 26 connecting link for 110056 chain	1
10	Vertical slide for feed roll beam	1
11	Eccentric bush for feed roll drive chain tensioner	1
12	Right hand feed roll swing	1
13	Left hand feed roll swing	1
14	25mm. I.D. x 30mm. O.D. x 25mm. long bronze bush	4
15	Feed roll mount flange	2
16	Top spiral feed roll - saw tooth - narrow	2
17	Top spiral feed roll - saw tooth	2
18	Feed roll spacer	2
19	Draw bolt	2
20	'C' washer	2
21	Bearing 6006 2RS	2
22	Feed roll shaft - left hand	1
23	Feed roll swing - left hand	1
24	Bearing 6205 2Z	2
25	52mm. internal circlip No: 5000/206	2
26	Spacer for feed roll shaft drive sprocket	2
	No: 26 connecting link for 110046 chain	2
27	"RENOLD" roller chain NO: 110046 12.7mm. (1/2in.) x 31 pitches	2
28	Chain sprocket for feed roll shaft	2
29	8mm. x 7mm. x 20mm. long key	2
30	M8. x 20mm. long hexagon head screws	2
31	End washer for locking feed roll shaft drive sprocket	2
32	Feed rolls drive sprocket	1
33	42mm. internal circlip	2

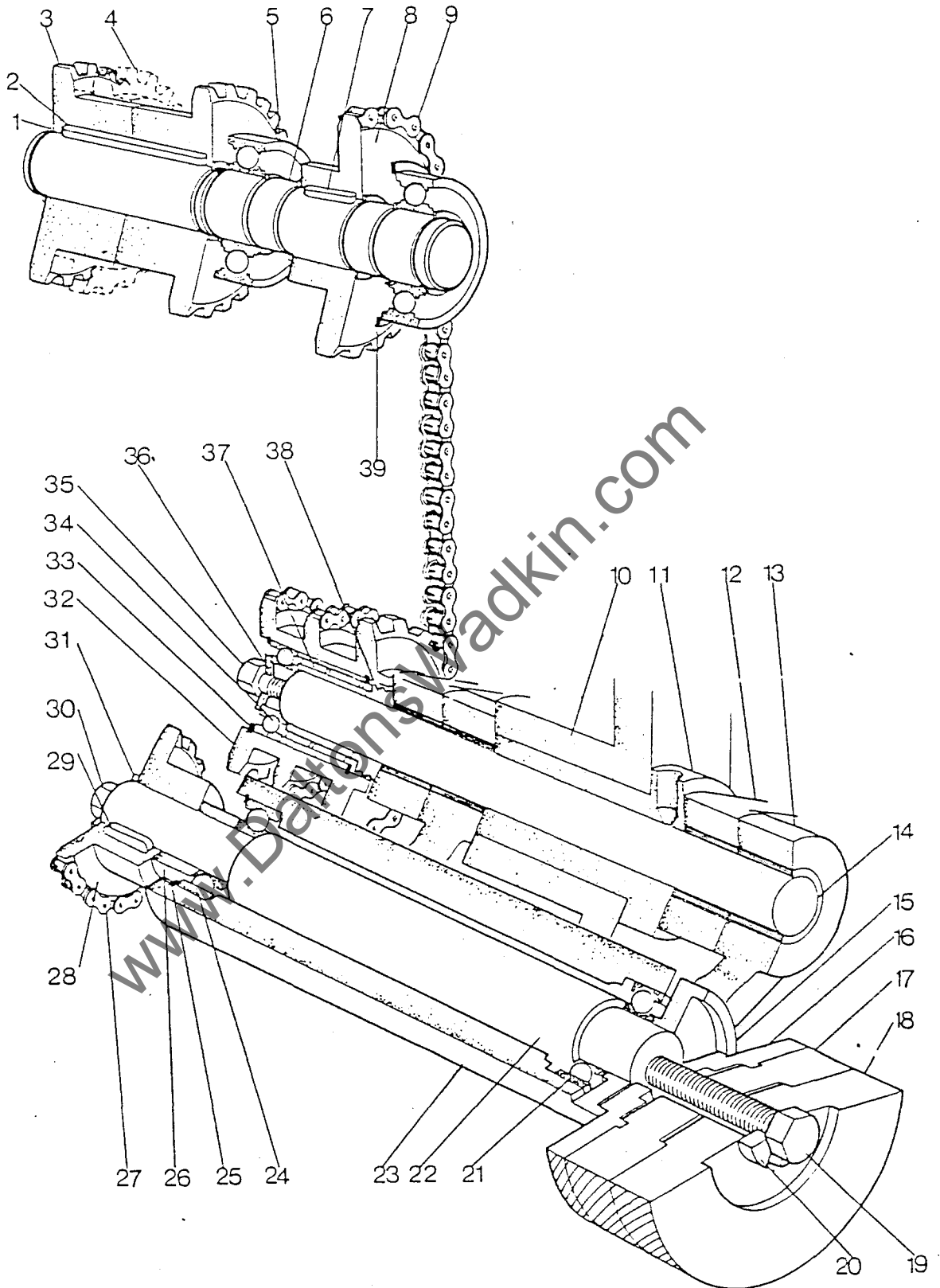

FEEDROLL UNIT AFTER TOP HEAD OR BETWEEN SECOND BOTTOM HEAD AND UNIVERSAL HEAD PNEUMATIC OR SPRING LOADED CHAIN DRIVEN,

ALWAYS QUOTE MODEL AND MACHINE NUMBER WHEN ORDERING SPARES

www.DaltonsWadkin.com

FEEDROLL UNIT AFTER TOP HEAD OR BETWEEN SECOND BOTTOM HEAD AND UNIVERSAL HEAD
PNEUMATIC OR SPRING LOADED CHAIN DRIVEN.....CONTD.

REF.NO:	DESCRIPTION	NO:OFF
34	Bearing 6004 Z	1
35	M8. x 16mm. long hexagonal head screws	1
36	Retaining washer for feed roll drive sprocket	1
37	"INA" bearing NA 6905	1
38	Grease retainer for feed roll swings	1
39	Internal circlip bore size 62	1

www.DaltonsWadkin.com

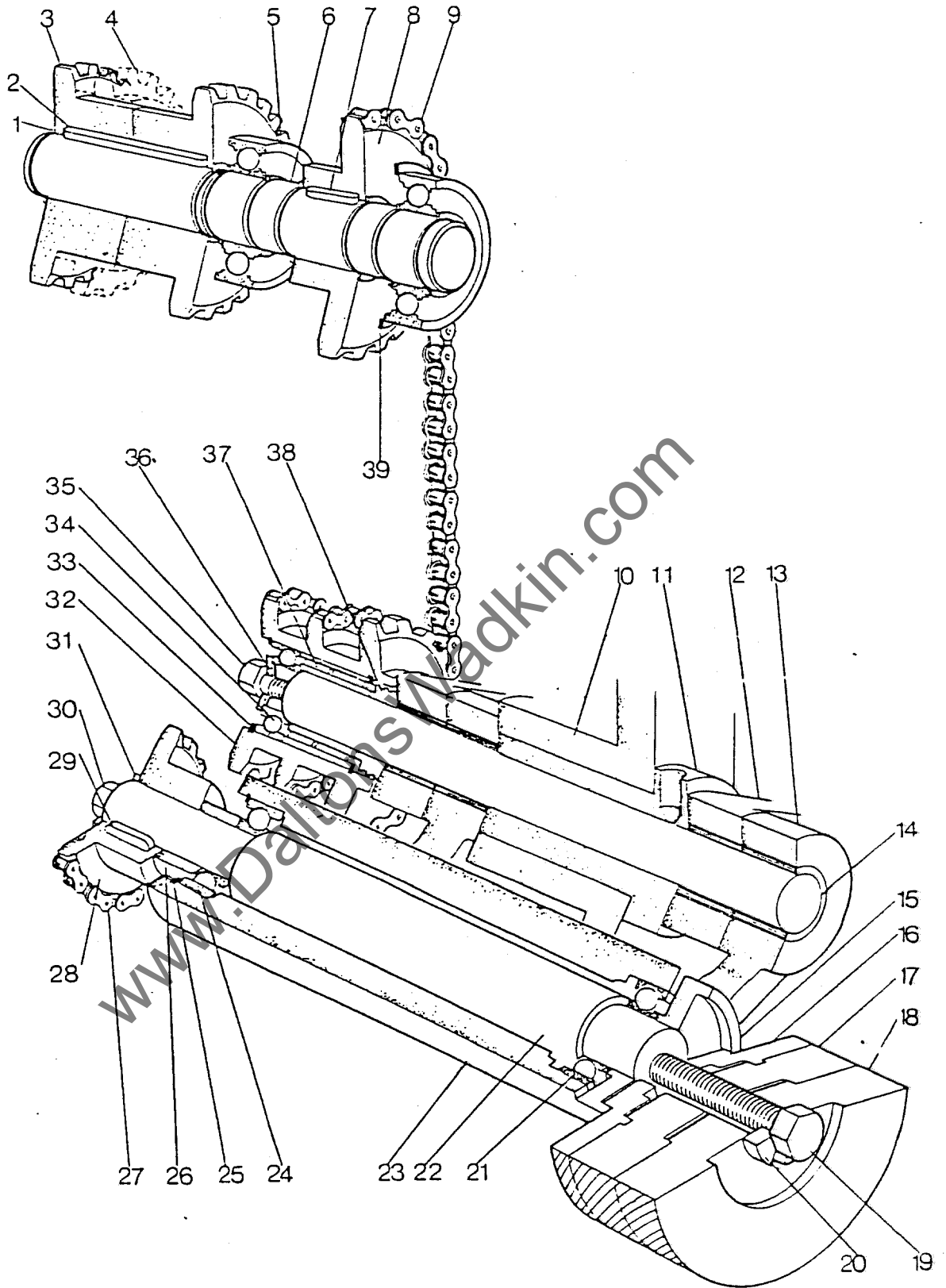

FEEDROLL UNIT AFTER TOP HEAD OR BETWEEN SECOND BOTTOM HEAD AND UNIVERSAL HEAD PNEUMATIC OR SPRING LOADED CHAIN DRIVEN.

DRIVE TO CHAIN DRIVEN FEED WORKS

REF.NO:	DESCRIPTION	NO:OFF
1	Chain guard and cover for Feed Roll Drive Unit	1
2	First "DUPLEX" sprocket for Feed Roll Drive Unit	1
3	"RENOLD" "DUPLEX" roller chain No: 114056, 15.8mm (5/8in.) pitch x 61 links	1
4	Chain connecting link No:26 for chain No:14056	1
5	Arm for chain tensioning	1
6	Chain tension wheel	1
7	Spindle for chain tensioner	1
8	Hexagon nut - size M12.	1
9	Single coil spring washer 12mm. dia.	1
10	Bright mild steel washer - M16. dia.	1
11	Bracket for chain tensioning arm on Feed Roll Unit	1
12	Washer 10mm. dia.	1
13	Hexagon head screws - M10.dia. x 30mm. long	2
14	Hexagon head screws - M8. dia. x 40mm. long	2
15	Single coil spring washers 8mm. dia.	2
16	"DUPLEX" sprocket for rear chain drive to Feed Rolls 18T.	1

www.DaltonsWadkin.com

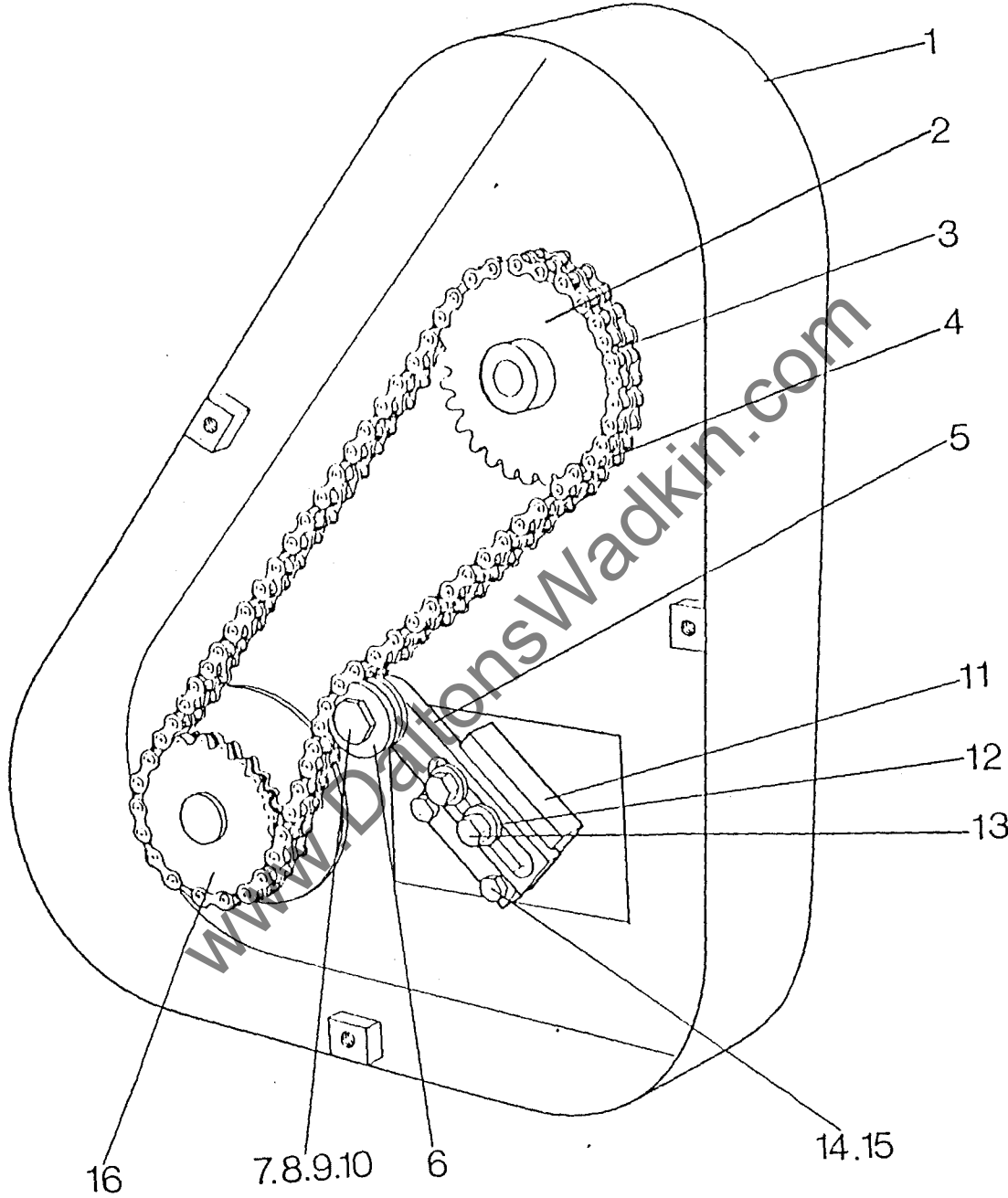

DRIVE TO CHAIN DRIVEN FEED WORKS
www.DaltonsWadkin.com
(Cover Removed)

FEED ROLL DRIVING CHAINS TENSIONING MECHANISM

REF.NO:	DESCRIPTION	NO:OFF
1	Chain tension wheel	4
2	Spindle for chain tensioners	4
3	Bright mild steel washers - size M16	4
4	Arm for chain tensioner	4
5	Hexagon head screws M10. dia. x 30mm. long	8
6	Bright mild steel washers - size M10.	8
7	Bracket for feed roll chain tensioners	2
8	Hexagon socket screws M10.dia. x 25mm. long	4
9	Spring washer - single coil 10mm. dia.	4
10	Hexagon nut - size M12.	4
11	Spring washer - single coil 12mm. dia.	4

www.DaltonsWadkin.com

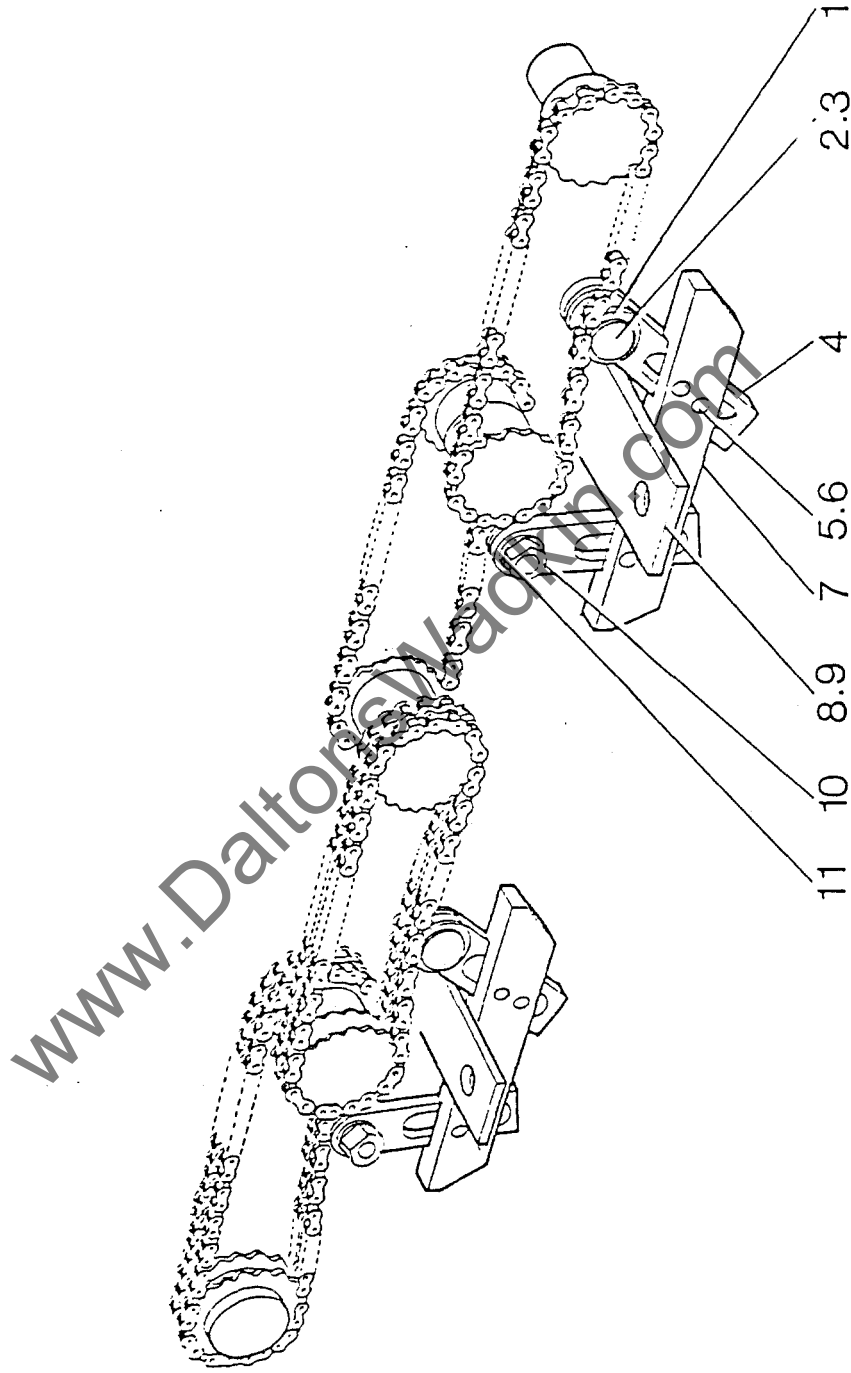

FEED ROLL DRIVING CHAINS TENSIONING MECHANISM

"SIMPLABELT" VARIABLE SPEED DRIVE UNIT - TYPE 11.332.16.16.2

REF.NO:	DESCRIPTION	NO:OFF	
1	Spur gear transmission - drive	1	
2	Housing	1	
3	Lock washer - spring ring DIN 128	1	
4	Hexagon head bolt DIN 933	1	
5	Standard three-phase motor	1	
6	Lock washer - spring ring DIN 128	1	
7	Hexagon head Bolt DIN 933	1	
8	Clamp collar - adaptor sleeve DIN 1481	1	
9	Spring loaded adjustment plate - pulley	1	
10	Locking plate - disc	1	
11	Plate - disc OR nut DIN 125	1	
12	Cheese head screw DIN 912	1	
13	Mechanically adjustable adjustment plate - disc pulley	1	
14	Locking plate - disc	1	
15	Plate - disc OR nut DIN 125	1	
16	Hexagon head bolt DIN 931	1	
17	Wide vee belt	1	
18	Protective hood - guard	1	
19	Lock washer - spring ring	1	
20	Cheese head screw DIN 912	1	
21	Hand adjustment	1	
22	Lock washer - spring ring	1	
23	Cheese head screw DIN 912	1	
≠	24		
≠	25		
≠	26		
	27	Locking screw - bolt	1
+	28		
	29	Clamping collar - adaptor sleeve DIN 1481	1
	30	Hexagon nut DIN 934	1
	31	Stud bolt - tap end stud	1
	32	Protective cap	1
	33	Hexagon nut DIN 986	1
≠	34		

≠ withdrawn

+ Not supplied

EXPLODED VIEW : "SIMPLABELT" VARIABLE SPEED DRIVE UNIT - TYPE 11.332.16.16.2

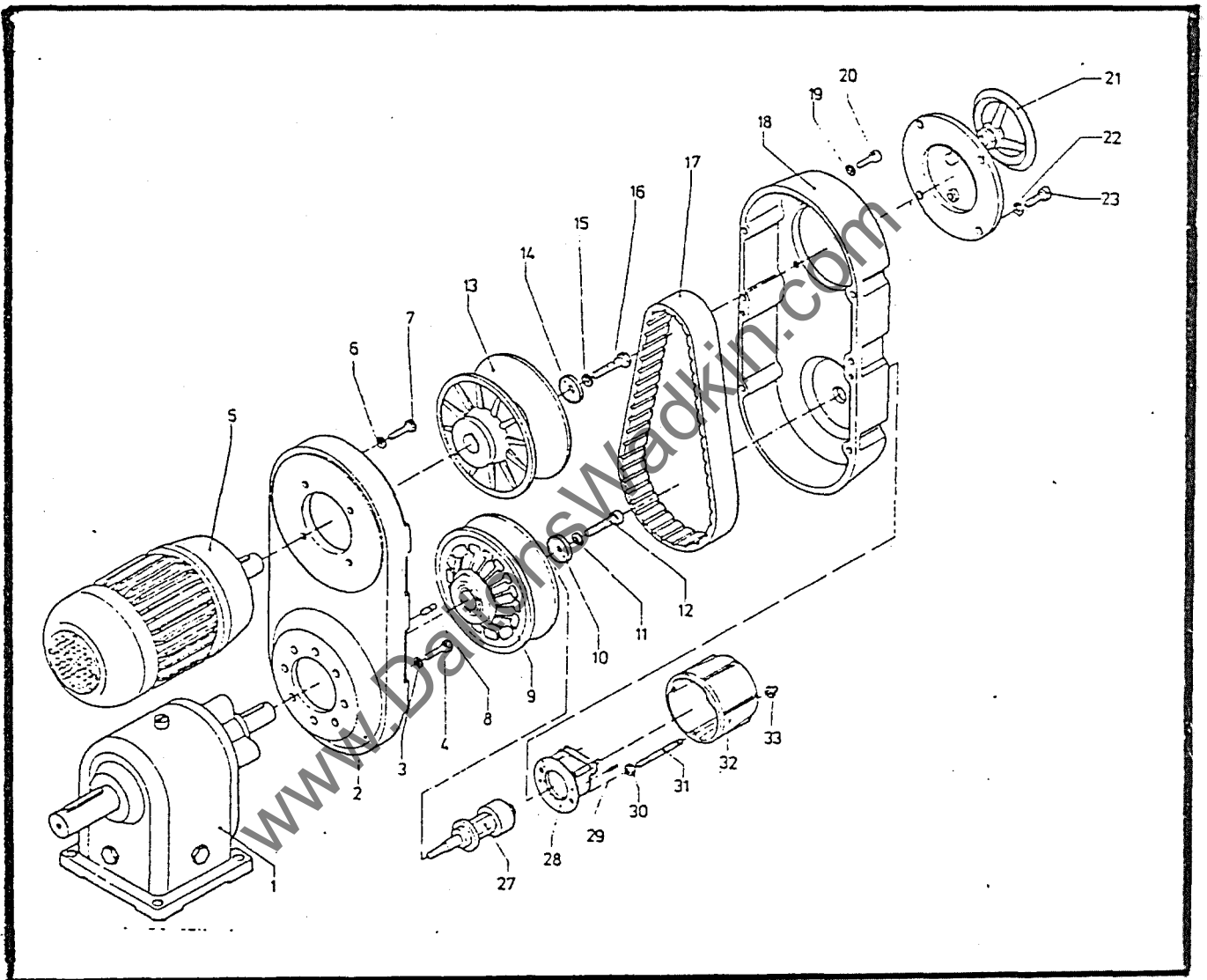

FIRST BOTTOM HEAD

REF.NO:	DESCRIPTION	NO:OF.
1	M12. blind hole standard handwheel - black plastic moulding	1
2	Locking screw for guard for First Bottom Head cutterblock	1
3	Locking pad for guard for First Bottom Head cutterblock	1
4	Top sliding guard over First Bottom Head spindle	1
5	Slide strip	1
6	Bottom Head spindle housing vertical slide	1
7	Pulley belt housing for horizontal heads	1
8	Spindle pulley for Bottom Heads and Top Head spindles - using D 132 MD Motor - 15 HP.	1
9	"FENNER" vee belts	3
10	"FENNER" vee belt motor pulley	1
11	"FENNER" taper lock bush No.2012 38mm. bore	1
12	M10. x 30mm. long hexagon head screws	4
13	10mm. dia. spring washers - single coil	4
14	Bracket nut for Second Bottom Head - vertical adjustment	1
15	Vertical adjustment screw for Horizontal heads	1
16	M10. x 30mm. long hexagon head screws.	2
17	Bearing bracket for vertical adjustment on Horizontal heads	1
18	Bearing No. 51104	2
19	Handwheel for rise and fall of Bottom Heads	1
20	No.5. taper pin	1
21	10mm. dia. spring washers - single coil	2
22	Main frame	1
23	M12. x 25mm. Male "BRISTOL" type "KIPP" type handle	1
24	Extension for vertical lock to horizontal heads	1
* 25	Front guard for First Bottom Head spindle	1

* Not shown

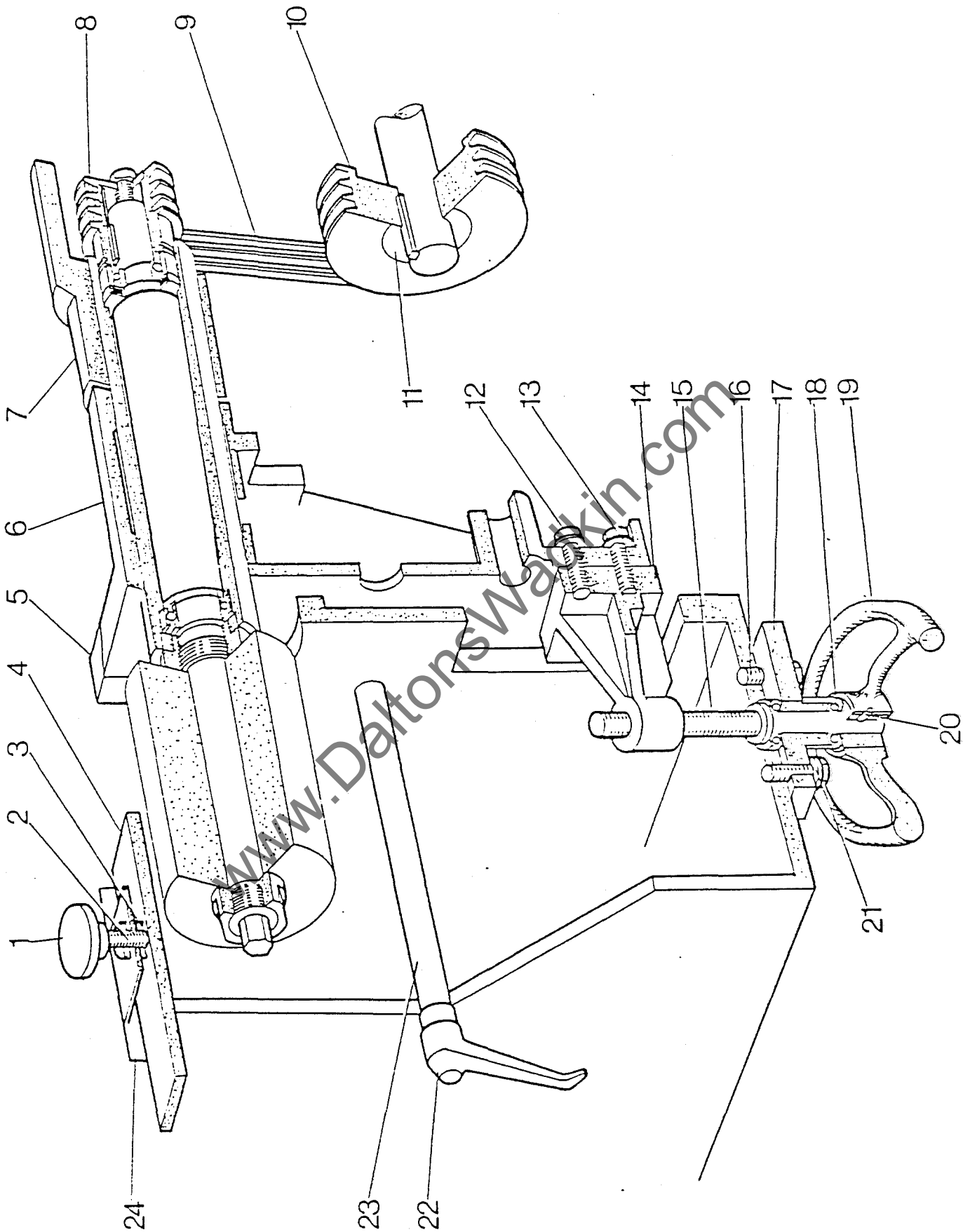

FIRST BOTTOM HEAD

ALWAYS QUOTE MODEL AND MACHINE NUMBER WHEN ORDERING SPAPES

www.DaltonsWadkin.com

NON-CANTING FENCE SIDE HEAD CARRIAGE UNIT ADJUSTING MECHANISM - INCLUDING DUST EXTRACTION HOOD.

REF.NO:	DESCRIPTION	NO:OFF
1	Exhaust Hood	1
2	Fence Side Head spindle carriage	1
3	Nut for lateral movement	1
4	Hexagon head screws M8. dia. x 25mm. long	2
5	Horizontal shaft for lateral movement	1
6	Front horizontal shaft for vertical movement	1
7	Nut for vertical adjustment	1
8	Hexagon head screws M10. dia. x 80mm. long	1
9	Bright mild steel washer size M10.	2
10	Hexagon nuts size M10.	1
11	Rear horizontal shaft for vertical adjustment	1
12	Collar for horizontal shaft for vertical adjustment	1
13	Mitre gear bracket for side head vertical adjustment	1
14	Straight mitre bevel gear (16T 2.5MOD)	1
14a	Straight mitre bevel gear (16T 2.5MOD)	1
15	Hexagon socket screw - cup point M6. dia. x 6mm. long	1
16	"INA" bearing AXK 2542 M6. dia. x 6mm. long	2
17	"INA" bearing AS 2542 M6. dia. x 6mm. long	2
18	"INA" bearing LS 2542 M6. dia. x 6mm. long	2
19	Chamfered notch nut M24 x 1.5	2
20	Vertical screw for side head vertical adjustment	1
21	Large dia. Mild steel washer size M10.	1
22	Hexagon head screw M10. x 20mm. long	1
23	Locking shaft for fence side head spindle barrel	1
24	Clamping block for side head horizontal movement	1
25	Hexagon socket screws M8. dia. x 35mm. long	2
26	Legend plate	1
27	'U' type drive screws No.6 - 3/8in. long	2
28	Male "BRISTOL" type "KIP" handle M12. x 25mm.	1
29	M12. self locking nut	1

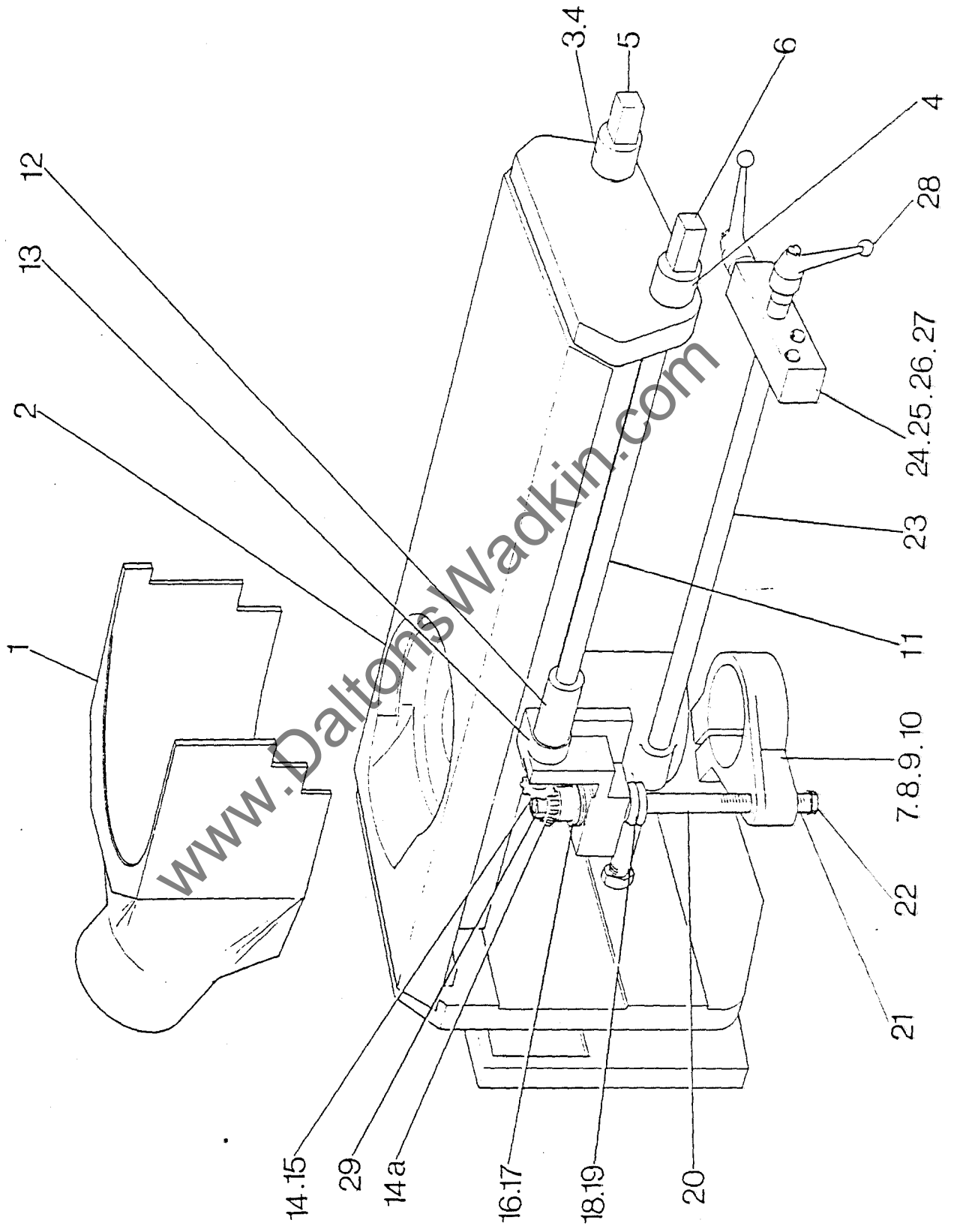

NON - CANTING FENCE SIDE HEAD CARRIAGE UNIT ADJUSTING MECHANISM

ALWAYS QUOTE MODEL AND MACHINE NUMBER WHEN ORDERING SPAPES

www.DaltonsWadkin.com

NON-CANTING NEAR SIDE HEAD CARRIAGE UNIT ADJUSTING MECHANISM - INCLUDING DUST EXTRACTION HOOD.

REF.NO:	DESCRIPTION	NO:OFF
1	Exhaust hood	1
2	Near Side Head spindle carriage	1
3	Nut for lateral movement	1
4	Hexagon head screws M8. dia. x 25mm. long	2
5	Horizontal shaft for lateral movement	1
6	Front horizontal shaft for vertical movement	1
7	Nut for vertical adjustment	1
8	Hexagon head screws M10. dia. x 80mm. long	1
9	Bright mild steel washer size M10.	2
10	Hexagon nuts size M10.	1
11	Rear horizontal shaft for vertical adjustment	1
12	Collar for horizontal shaft for vertical adjustment	1
13	Mitre gear bracket for side head vertical adjustment	1
14	Straight mitre bevel gear (16T 2.5MOD)	1
14a	Straight mitre bevel gear (16T 2.5MOD)	1
15	Hexagon socket screw - cup point M6.dia. x 6mm. long	1
16	"INA" bearing AXK 2542 M6. dia. x 6mm. long	2
17	"INA" bearing AS 2542 M6. dia. x 6mm. long	2
18	"INA" bearing LS 2542 M6. dia. x 6mm. long	2
19	Chamfered notch nut M24. x 1.5	2
20	Vertical screw for side head vertical adjustment	1
21	Large dia. mild steel washer size M10.	1
22	Hexagon head screw M10. x 20mm. long	1
23	Locking shaft for near side head spindle barrel	1
24	Clamping block for side head horizontal movement	1
25	Hexagon socket screws M8. dia. x 35mm. long	2
26	Legend plate	1
27	'U' type drive screws No.6 - 3/8in. long	2
28	Male "BRISTOL" type "KIP" handle M12. x 25mm.	1
29	M12. self locking nut	1

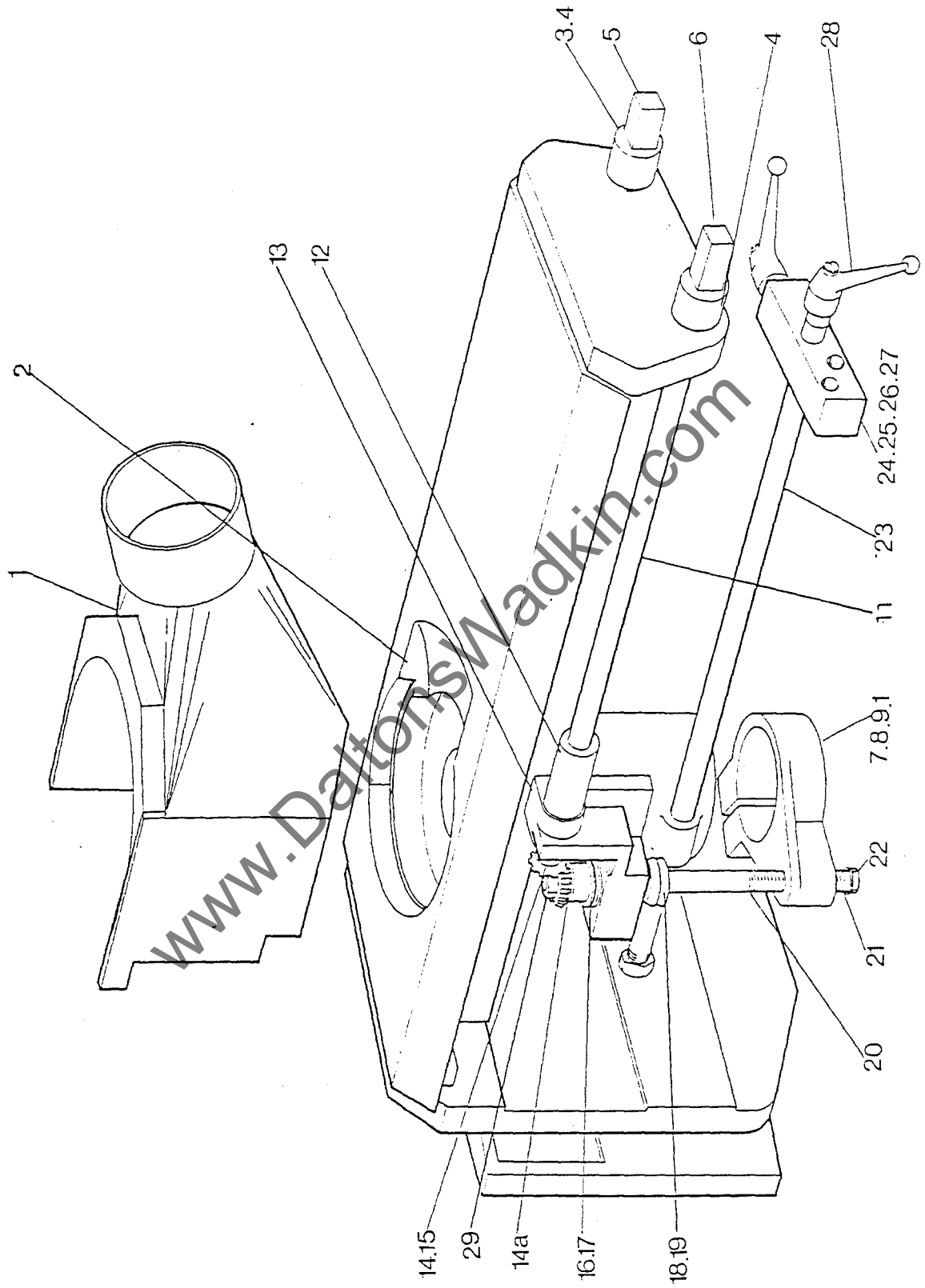

NON - CANTING NEAR SIDE HEAD CARRIAGE UNIT ADJUSTING MECHANISM

ALWAYS QUOTE MODEL AND MACHINE NUMBER WHEN ORDERING SPARES

www.DaltonsWadkin.com

TOP HEAD - INCLUDING POWER RISE AND FALL

REF.NO:	DESCRIPTION	NO:OFF
1	Nut for horizontal head adjustment - Axial	1
2	Shaft for horizontal head adjustment - Axial	1
3	M24. x 1.5 chamfered notch nuts	2
4	Bearing bracket for horizontal adjustment	1
5	"INA" bearings AXK 2542	2
6	"INA" bearings AS 2542	4
7	Sprocket for horizontal head axial adjustment	1
8	"FENNER" vee belt motor pulley	1
9	"FENNER" vee belt	3
10	"RENOLD" Roller chain No. 111046 12.9mm.(1/2in.) pitch, 40 pitches including connecting link	1
11	No.4. taper pin	2
12	Shaft for horizontal head cross adjustment	2
13	20mm. I.D. x 25mm. O.D. x 20mm. long bronze bush	2
14	Slide strip	1
15	Top head vertical slide	1
16	Screw for top head rise and fall	1
17	Nut for top head rise and fall	1
18	M8. x 25mm. long hexagonal head screws	2
19	Top cover to worm gear housing rise and fall for top beam	1
20	25mm. I.D. x 30mm. O.D. x 20mm. long bronze bush	1
21	Worm rise and fall to top beam and top head	1
22	Bearing 6204	2
23	Clutch for top head rise and fall	1
24	6mm. dia. x 32mm. long tension pin	1
25	M6. x 6mm. long hexagonal socket screw - cup point	1
26	16mm. dia. bore 'F' series 2 loose collar	1
27	"INA" bearing AS 2035	1
28	"INA" bearings AXK 2035	1
29	"INA" bearing WS 81104	1
30	"INA" bearing AS 1730	2
31	"INA" bearing AXK 1730	1
32	Straight mitre bevel gear (16T 2.5 Mod)	2
33	5mm. x 5mm. x 20mm. long key	2
34	M6. x 6mm. long hexagonal socket head screws	2
35	"INA" bearing AS 2035	1
36	"INA" bearing AXK 2035	1
37	M6. x 10mm. long hexagonal socket screw - cup point	1

GA 274

www.DaltonWadkin.com

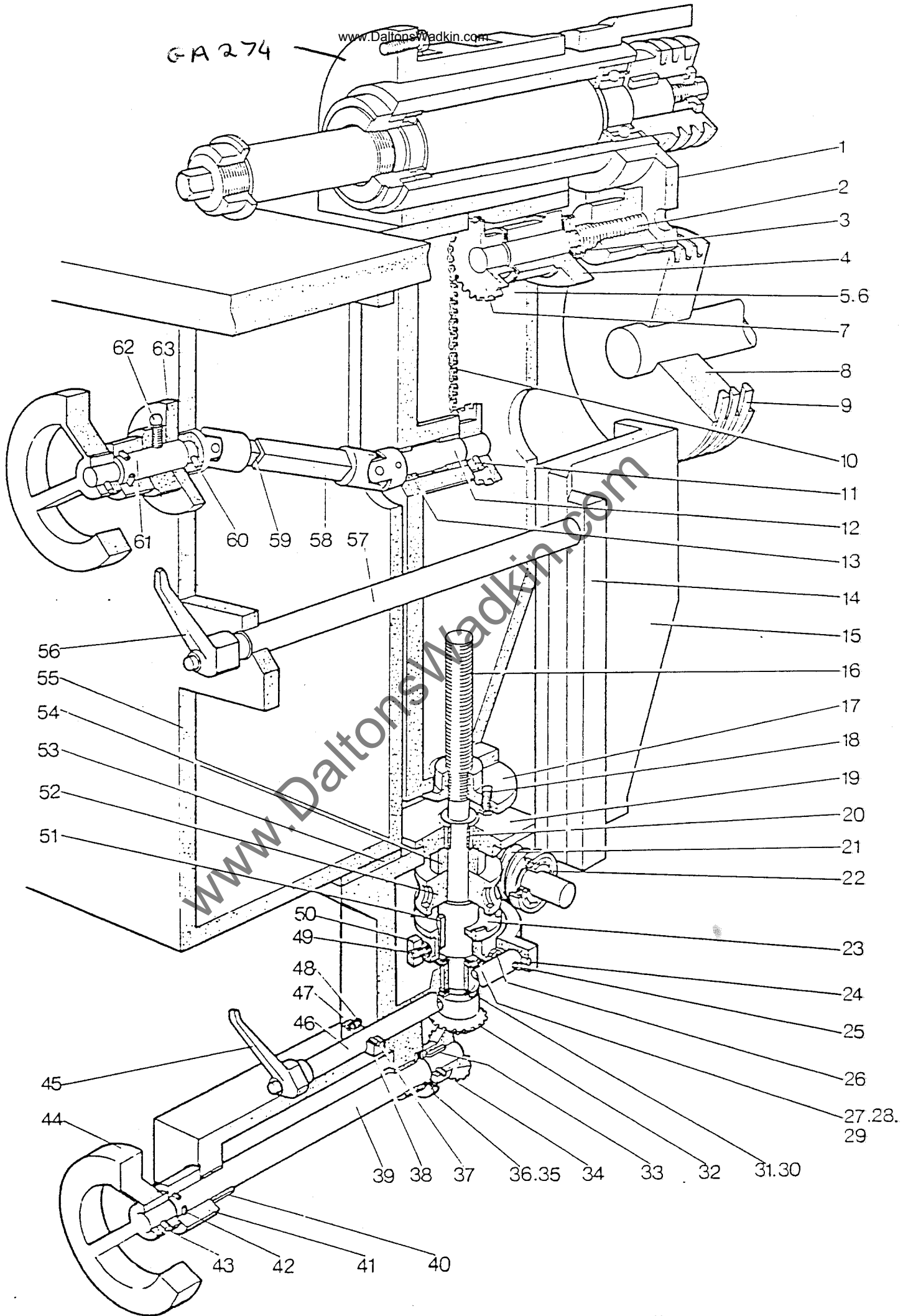

ALWAYS QUOTE MODEL AND MACHINE NUMBER WHEN ORDERING SPARES

www.DaltonsWadkin.com

TOP HEAD - INCLUDING POWER RISE AND FALL.....CONTD

REF.NO:	DESCRIPTION	NO:OFF
38	Clutch location arm for top head rise and fall	1
39	Handwheel shaft for top head rise and fall	1
40	20mm. I.D. x 25mm. O.D. x 20mm. long bronze bush	3
41	Calibrated dial for adjusting screws	2
42	'O' Ring "GACO" RM 0196 - 24	2
43	No.4. taper pin	1
44	16mm. O.D. bore "RENCOL" handwheel (cast iron) spoked pattern without handle - Patt. No: 4125	2
45	M10. x 25mm. Male Bristol type "KIPP" handle	1
46	Clutch adjusting shaft for Top Head Rise and Fall	1
47	Spring for spindle lock	1
48	10mm. dia. steel ball	1
49	M6. x 10mm. long hexagonal socket screws	2
50	Clutch yoke for Top Head Rise and Fall	1
51	8mm. x 7mm. x 32mm. long key	1
52	Worm wheel for Top Head Rise and Fall	1
53	Packing plate for worm housing Top Head Rise and Fall	1
54	Spacer for Top Head Rise and Fall screw	1
55	Main Frame	1
56	M12. x 25mm. male Bristol type "KIPP" handle	1
57	Extension for vertical lock to horizontal heads	1
58	Universal coupling and square tube assembly for horizontal head adjustment	1
59	Universal coupling and square tube assembly for horizontal head cross adjustment	1
60	6mm. dia. x 32mm. long tension pin	1
61	Shaft for horizontal head cross adjustment (handwheel and sprocket)	2
62	1/8in. B.S.P. grease nipple 67.1/2 ⁰ NA 5799	1
63	Handwheel bearing block for horizontal headcross adjustment.	1

GA 274

www.DaltonsWadkin.com

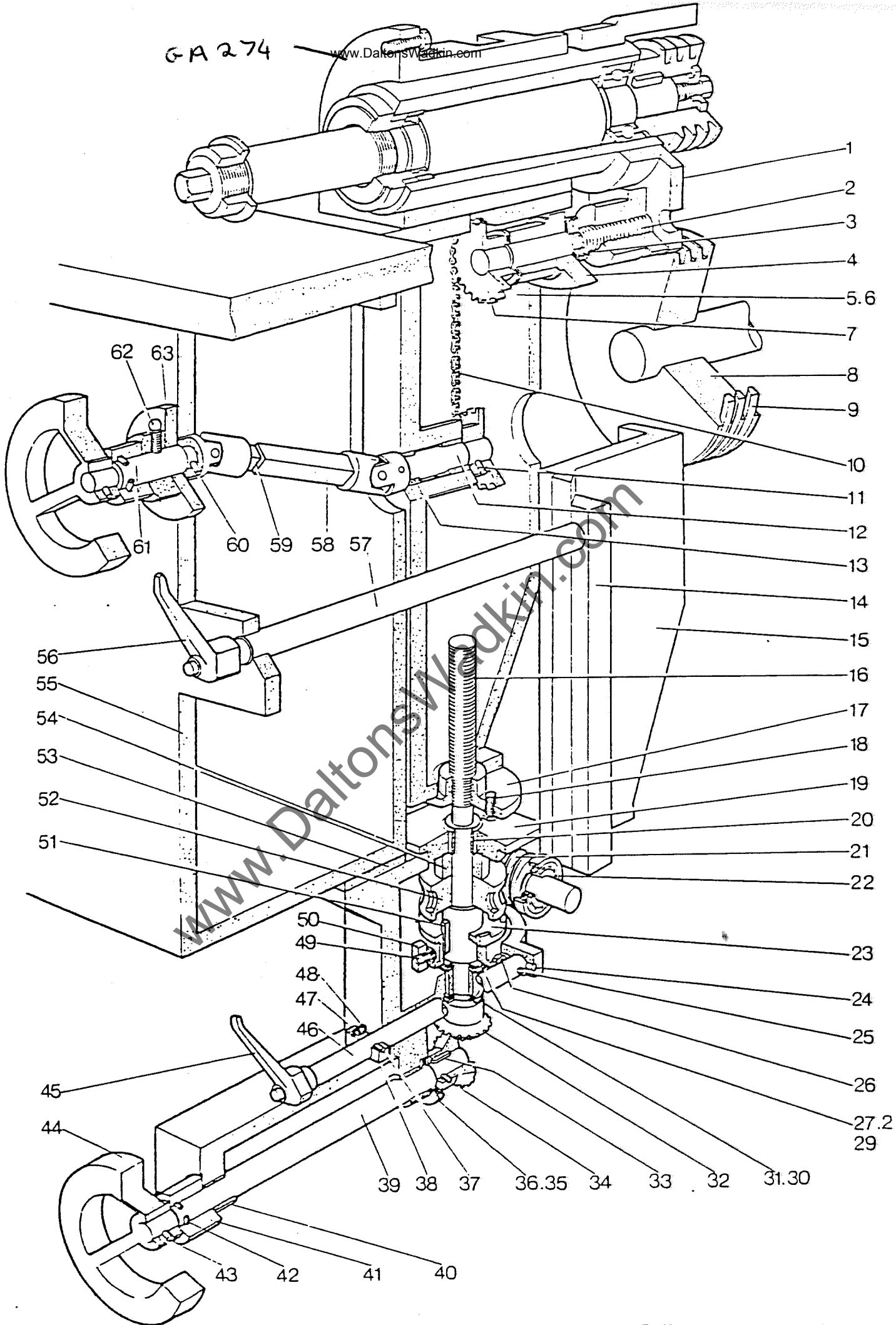

ALWAYS QUOTE MODEL AND MACHINE NUMBER WHEN ORDERING SPARES

www.DaltonsWadkin.com

ADJUSTMENTS FOR SECOND BOTTOM HEAD AND THIRD BOTTOM HEAD

REF.NO:	DESCRIPTION	NO:OFF
1	Slide strip	1
2	Bottom Head spindle housing vertical slide	1
3	Pulley belt housing for horizontal heads FOR 7.5HP, 10HP, 15HP Motor	1
	FOR 5.5HP Motor only	1
4	Spindle pulley for Bottom Heads and Top Head spindles - using D 132 MD Motor - 15 HP.	1
5	"FENNER" vee belts	3
6	"FENNER" vee belt motor pulley	1
	FOR 5.5HP Motor only	1
7	"FENNER" taper lock bush No.2012 38mm. bore FOR 7.5HP, 10HP, 15HP Motor	1
	FOR 5.5HP Motor only	1
8	Nut for horizontal head adjustment - Axial	1
9	Shaft for horizontal head adjustment - Axial	1
10	M24. x 1.5 chamfered notch nuts	2
11	"INA" bearing AXK 2542	2
	"INA" bearing AS 2542 - washers	4
12	Bearing bracket for horizontal adjustment - Axial	1
13	Sprocket for horizontal head Axial adjustment	2
14	"RENOLD" roller chain No. 111046 12.7mm. (1/2in.) pitch x 40 pitches - including connecting link	1
15	Shaft for horizontal head cross adjustment (handwheel / sprocket)	2
16	M10. x 30mm. long hexagon head screws	4
17	10mm. dia. spring washers - single coil	4
18	Bracket nut for second bottom head - vertical adjustment	1
19	Vertical adjustment screw for horizontal heads	1
20	M10. x 30mm. long hexagon head screws	2
21	Bearing bracket for vertical adjustment on horizontal heads	1
22	Bearing No. 51104	2
23	Handwheel for rise and fall of Bottom heads	1
24	No.5. taper pin	1
25	10mm.dia. spring washers - single coil	2
26	Universal coupling diameter square tube assembly for horizontal head cross adjustment	1
27	Universal coupling diameter square shaft assembly for horizontal head cross adjustment	1
28	Handwheel bearing block for horizontal head cross adjustment	1

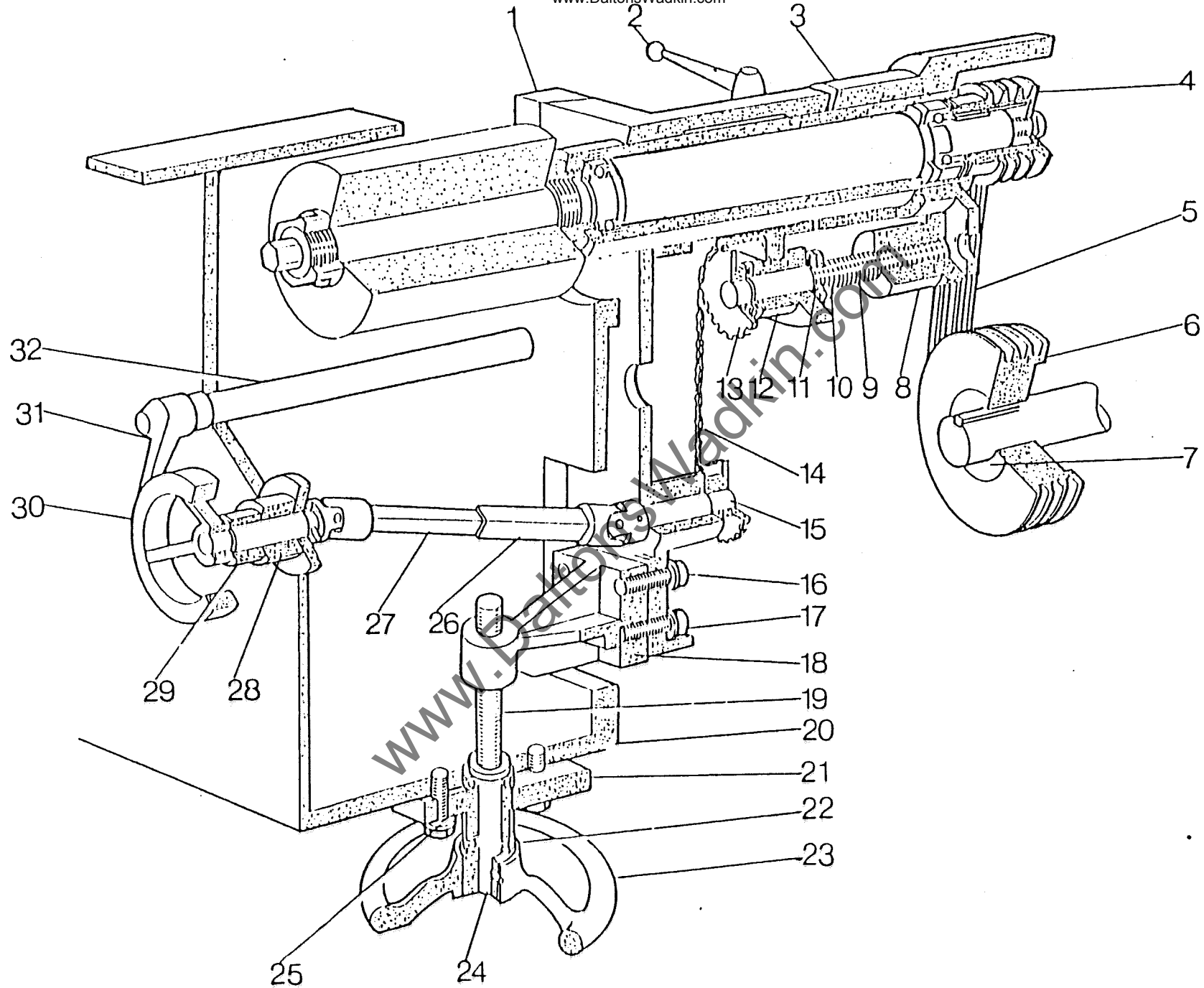

ADJUSTMENTS FOR SECOND BOTTOM HEAD AND THIRD BOTTOM HEAD

ADJUSTMENTS FOR SECOND BOTTOM HEAD AND THIRD BOTTOM HEADCONTD

REF.NO:	DESCRIPTION	NO:OFF
29	Calibrated dial for adjusting screws	1
30	16mm. bore "RENCOL" handwheel (cast iron) spoked pattern - without handle Part.NO.4125	1
31	Main frame	1
32	M12. x 25mm. Male "BRISTOL" type "KIPP" type handle	1

www.DaltonsWadkin.com

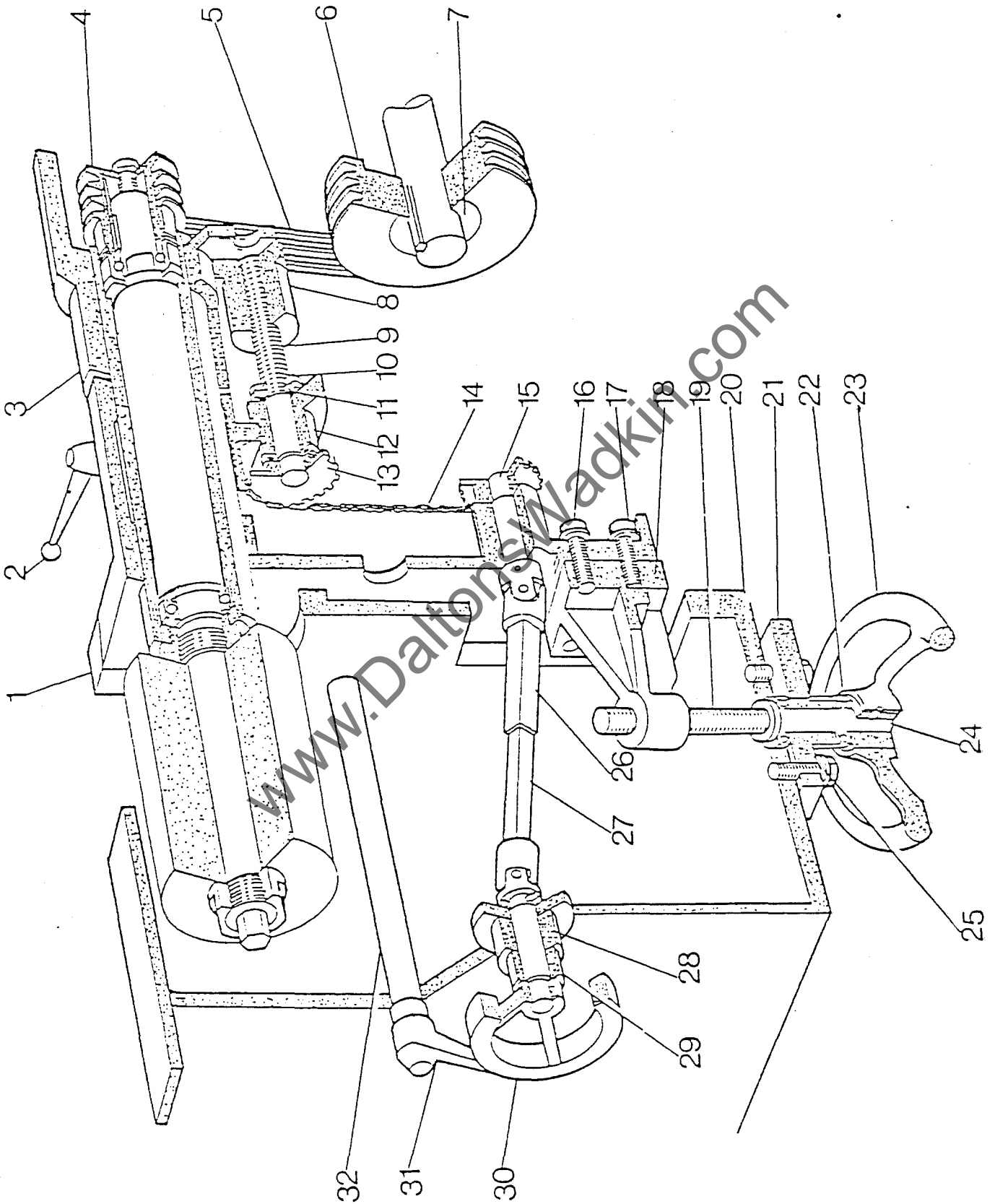

ADJUSTMENTS FOR SECOND BOTTOM HEAD AND THIRD BOTTOM HEAD

UNIVERSAL HEAD - ADJUSTING MECHANISM

REF.NO:	DESCRIPTION	NO:OFF
1	Universal head spindle 40mm. dia. square shoulder	1
2	Locking nut	1
3	Locking collar assembly	1
4	Traverse screw for vertical movement	1
5	Calibrated dial for traverse screw	1
6	Vertical slide stand	1
7	Male "BRISTOL" type "KIP" handle M10. x 50mm.	1
8	Saddle for universal head	1
9	Calibrated dial for traverse screw	1
10	Traverse screw for horizontal movement	1
11	Cross slide for universal head	1
12	Worm gear shaft	1
13	D.112 OR D.132 Electric Motor	1
14	See 54 - 57 } Pulley	1
15	See 54 - 57 } Belts	
16	GA 363 OR GA 42 Pulley belt housing to size of motor	1
17	GA 360 OR GA 37 Pulley belt housing cover to size of motor	1
18	Spindle carriage for universal head	1
19	Bolt for spindle carriage	1
20	Bolt for spindle carriage	1
21	Worm wheel for universal head	1

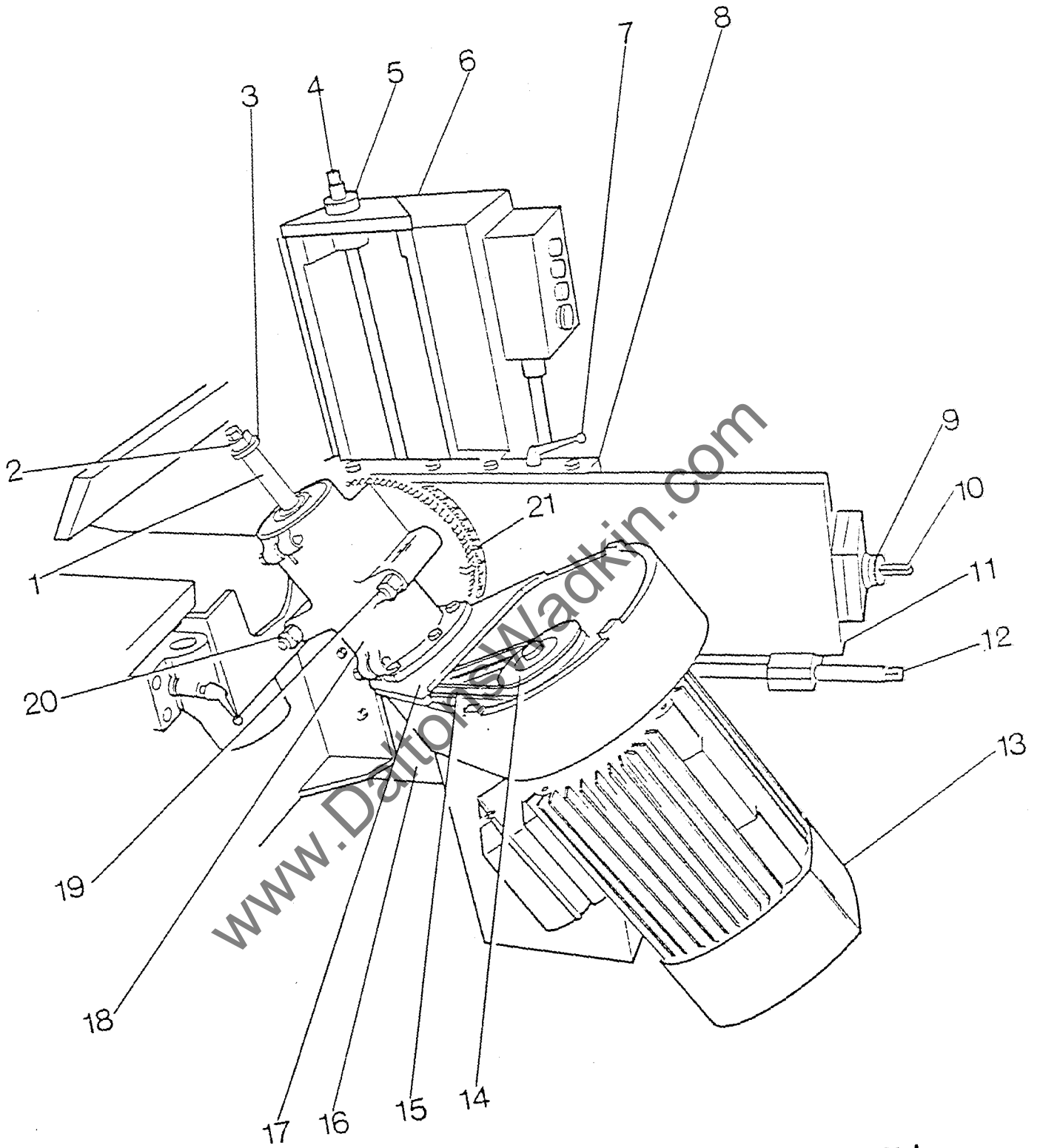

UNIVERSAL HEAD ADJUSTING MECHANISM

ALWAYS QUOTE MODEL AND MACHINE NUMBER WHEN ORDERING SPARES

www.DaltonsWadkin.com

BOTTOM HEAD SPINDLE UNIT 40MM. DIA. SQUARE SHOULDER

REF.NO:	DESCRIPTION	NO:OFF
1	Locking nut for Bottom Head and Near Side head spindles	1
2	40mm. dia. square shoulder Bottom Head Spindle	1
3	Bearing nut for Bottom Head and Near Side head spindles	1
4	Bearing nut for spindle housing	1
∅ 5	R.H.P. OR SKF. Bearing 6009	1
6	Barrel for Horizontal and Side Head spindle	1
∅ 7	R.H.P. OR SKF. Bearing 6306	1
8	8mm. x 7mm. x 40mm. long key	1
9	Pulley spigot for spindle	1
10	M12. x 45mm. long hexagonal head screw	1
11	"BELLEVILLE" SERIES 'K' disc spring for bearing 6306 71.5 O.D. x 45.5 I.D. x 0.7	6

∅ "KLUBER" Grease packed

www.DaltonsWadkin.com

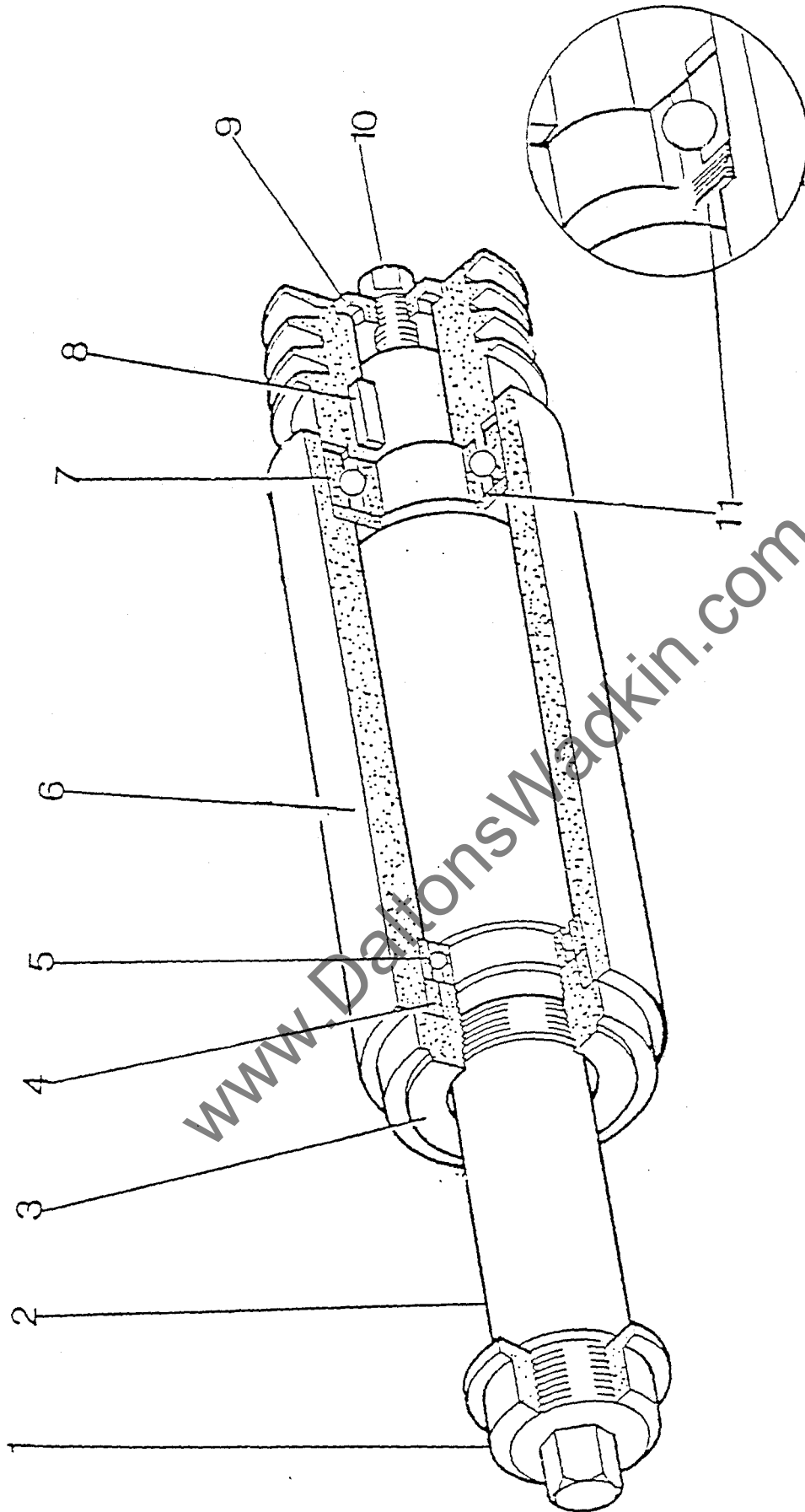

BOTTOM HEAD SPINDLE UNIT 40mm DIAMETER SQUARE SHOULDER

ALWAYS QUOTE MODEL AND MACHINE NUMBER WHEN ORDERING SPARES

www.DaltonsWadkin.com

FENCE SIDE HEAD SPINDLE UNIT 40MM. DIA.SQUARE SHOULDER

REF.NO:	DESCRIPTION	NO:OFF
1	Locking nut for Fence Side head, Top head and Universal head spindles	1
2	Bearing nut for Fence Side head, Top head and Universal head spindles	1
3	Bearing nut for spindle housing	1
∅ 4	R.H.P. OR SKF. bearing 6009	1
5	Barrel for Horizontal and Side head spindle	1
∅ 6	R.H.P. OR SKF bearing 6306	1
7	Pulley spigot for spindle	1
8	M12. x 35mm. long hexagon head screw	1
9	8mm. x 7mm. x 40mm. long key	1
10	"BELLEVILLE" SERIES 'K' disc spring for bearing 6306 7.5mm. O.D. x 45.5mm. I.D. x 0.7	6
11	40mm. dia. square shoulder Fence Side head spindle	1
∅	"KLUBER" grease packed	

www.DaltonsWadkin.com

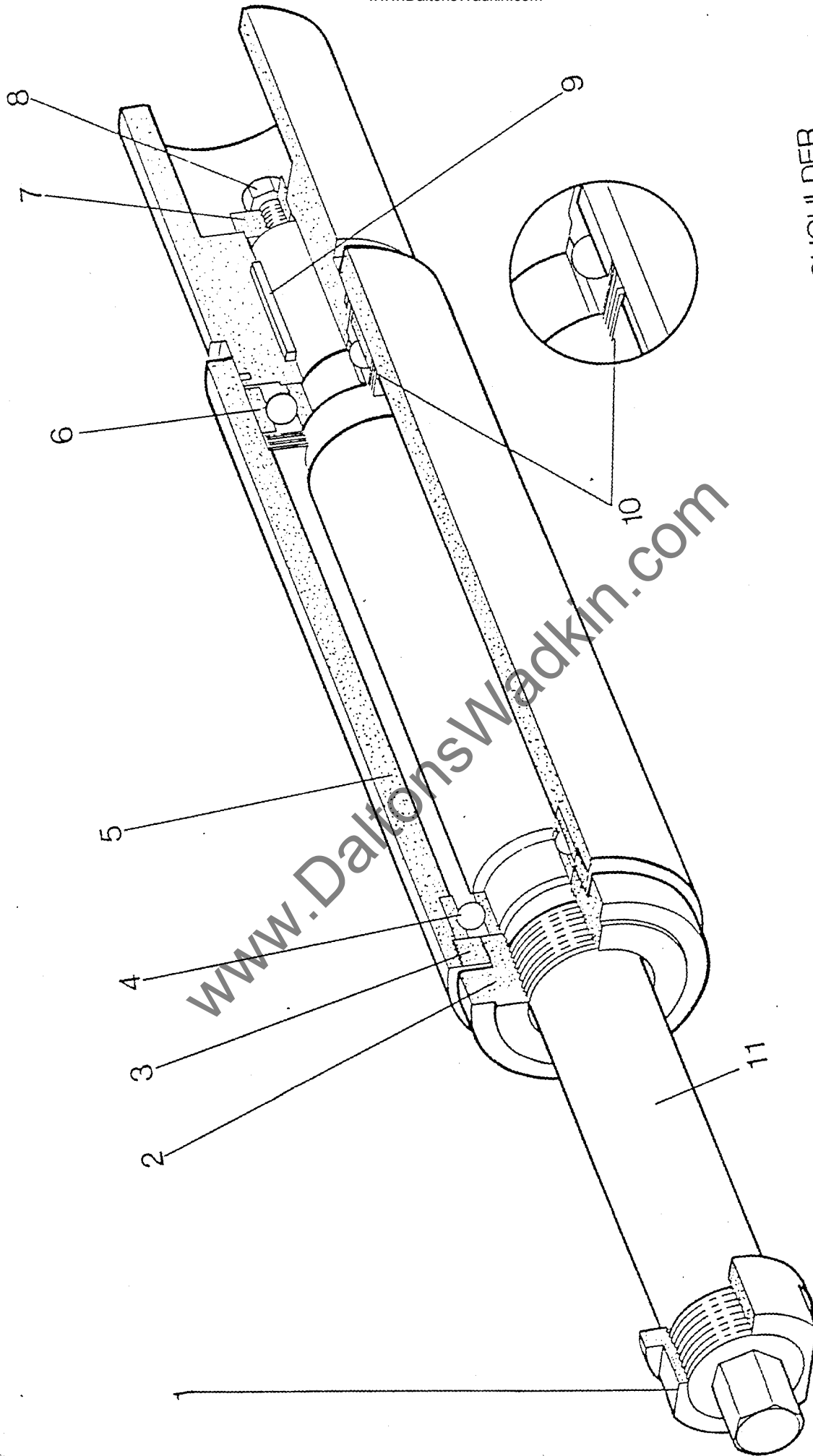

FENCE SIDE HEAD SPINDLE UNIT 40mm DIAMETER SQUARE SHOULDER

ALWAYS QUOTE MODEL AND MACHINE NUMBER WHEN ORDERING SPARES

www.DaltonsWadkin.com

NEAR SIDE HEAD SPINDLE UNIT 40MM. DIAMETER SQUARE SHOULDER

REF.NO:	DESCRIPTION	NO:OFF
1	Locking nut for Bottom head and Near Side head spindles	1
2	Bearing nut for Bottom head and Near Side head spindles	1
3	Bearing nut for spindle housing	1
∅ 4	R.H.P. OR SKF. Bearing 6009	1
5	Barrel for Horizontal and side head spindle	1
∅ 6	R.H.P. OR SKF. Bearing 6306	1
7	Pulley spigot for spindle	1
8	M12. x 35mm. long hexagonal head screw	1
9	8mm. x 7mm. x 40mm. long key	1
10	"BELLEVILLE" SERIES 'K' disc spring for bearing 6306 71.5 O.D. x 45.5 I.D. x 0.7	6
11	40mm. dia. square shoulder Near Side head spindle	1
∅	"KLUBER" grease packed	

www.DaltonsWadkin.com

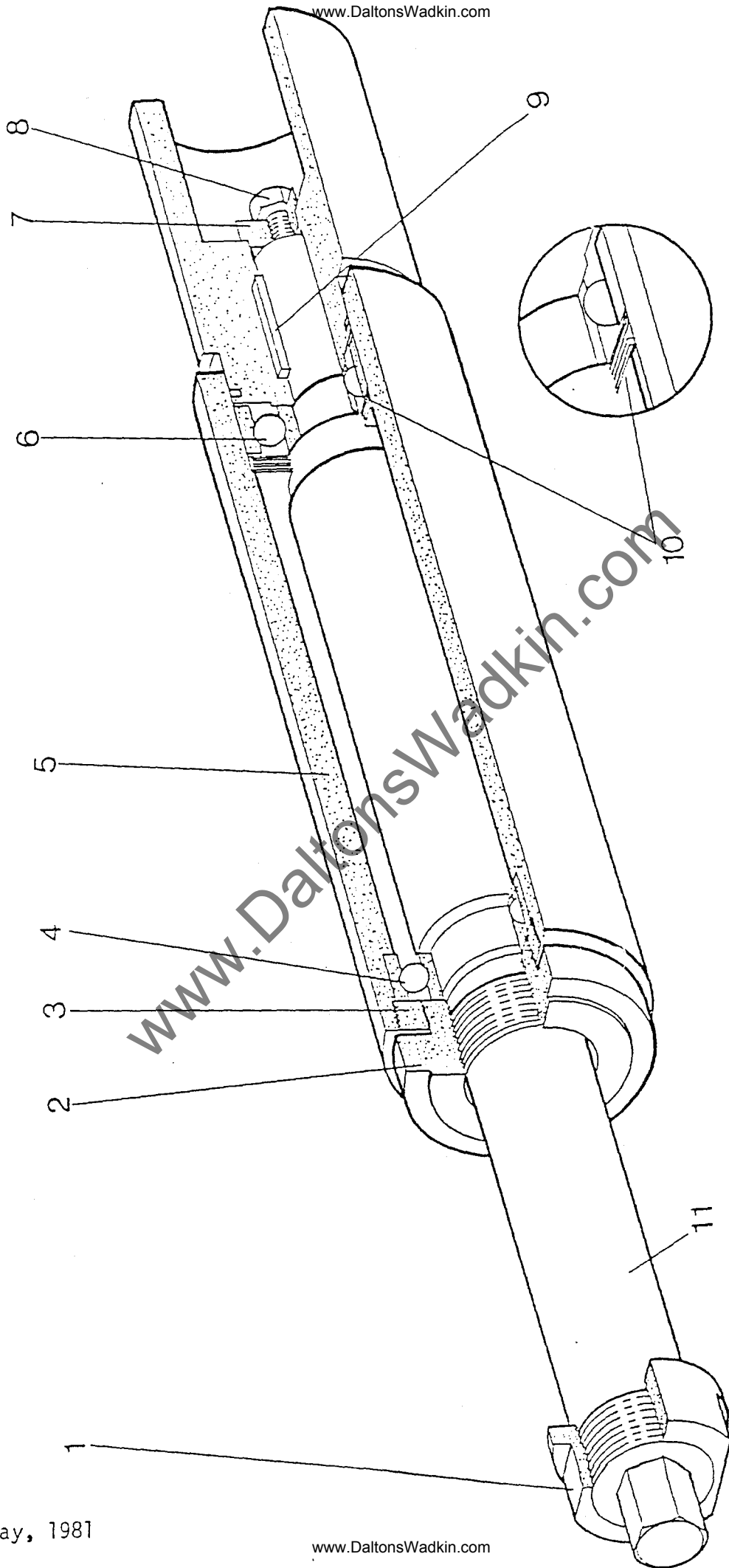

NEAR SIDE HEAD SPINDLE UNIT 40mm DIAMETER SQUARE SHOULDER

TOP HEAD SPINDLE UNIT 40MM. DIA. SQUARE SHOULDER

REF.NO:	DESCRIPTION	NO:OFF
1	Locking nut for Fence Side head, Top head, Universal head spindles	1
2	40mm. dia. square should top head spindle	1
3	Bearing nut for Fence Side, Top head and Universal head spindles	1
4	Bearing nut for spindle housing	1
∅ 5	R.H.P. OR SKF bearing 6009	1
6	Barrel for Horizontal and Side head spindle	1
∅ 7	R.H.P. OR SKF bearing 6306	1
8	8mm. x 7 mm. x 40mm. long key	1
9	Pulley spigot for spindle	1
10	M12. x 45mm. long hexagonal head screw	1
11	"BELLEVILLE" SERIES 'K' disc spring for bearing 6306 71.5 O.D. x 45.5 I.D. x 0.7	6
∅	"KLUBER" grease packed	

www.DaltonsWadkin.com

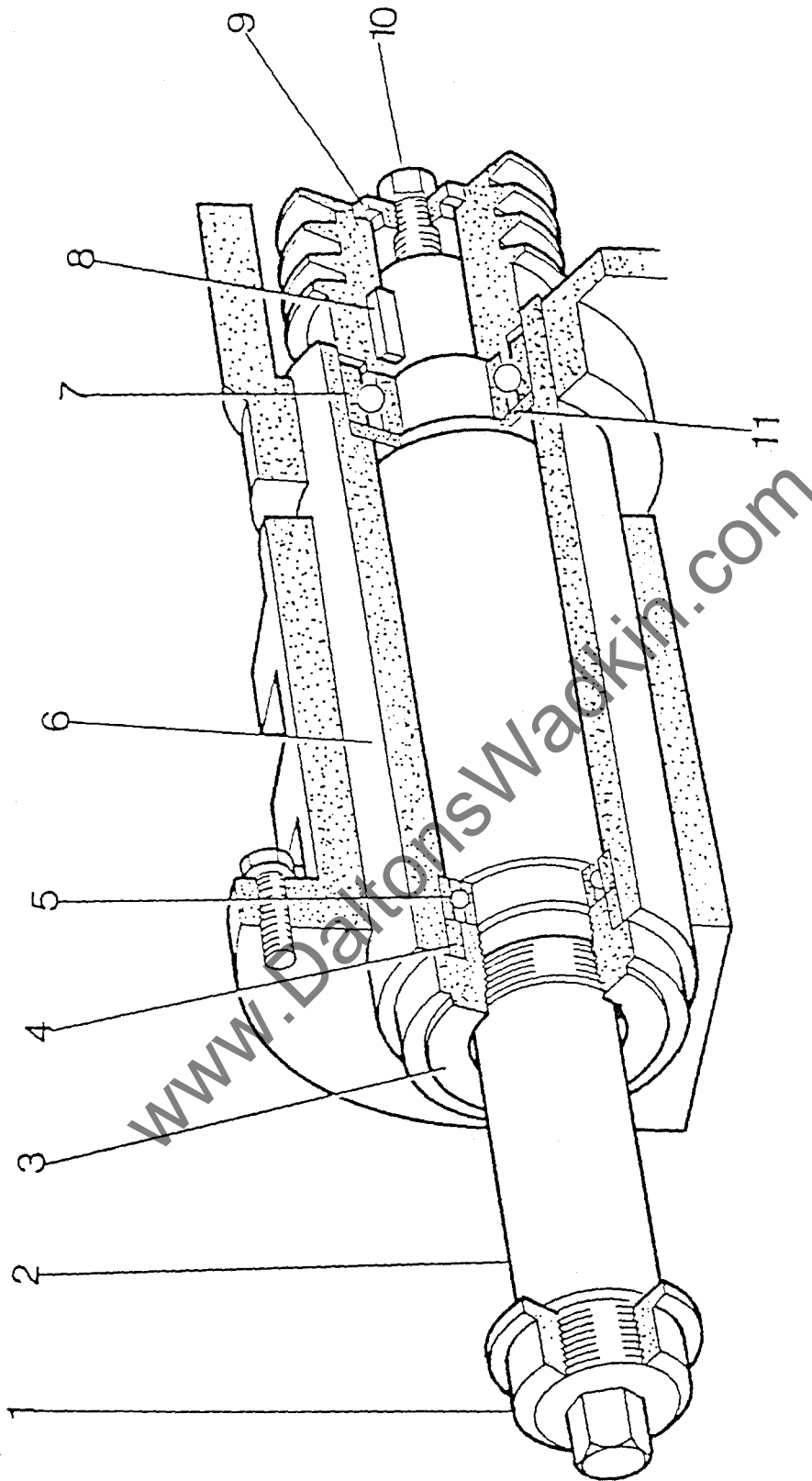

TOP HEAD SPINDLE UNIT 40mm DIAMETER SQUARE SHOULDER

UNIVERSAL HEAD SPINDLE 40MM. DIA. SQUARE SHOULDER

REF.NO:	DESCRIPTION	NO:OF
1	Locking nut for Fence side head, Top head and Universal head spindles	1
2	Locking collar assembly for 40mm. dia. Universal head spindle	
3	Supplied as a complete unit	1
4		
5	Bearing nut for Fence Side head, Top and Universal head spindles	1
6	Bearing nut for spindle housing	1
∅ 7	R.H.O. OR SKF. bearing 6009	1
8	Barrel for Universal head spindle	1
9	"BELLEVILLE" SERIES 'K' disc spring for bearing 6306 71.5 O.D. x 45.5 I.D. x 0.7	6
∅ 10	R.H.P. OR SKF bearing 6306	1
11	Pulley spigot for spindle	1
12	M12. x 45mm. long hexagon head screw	1
13	8mm. x 7mm. x 40mm. long key	1
14	40mm. dia. square shoulder universal head spindle	1
∅	"KLUBER" grease packed	

www.DaltonsWadkin.com

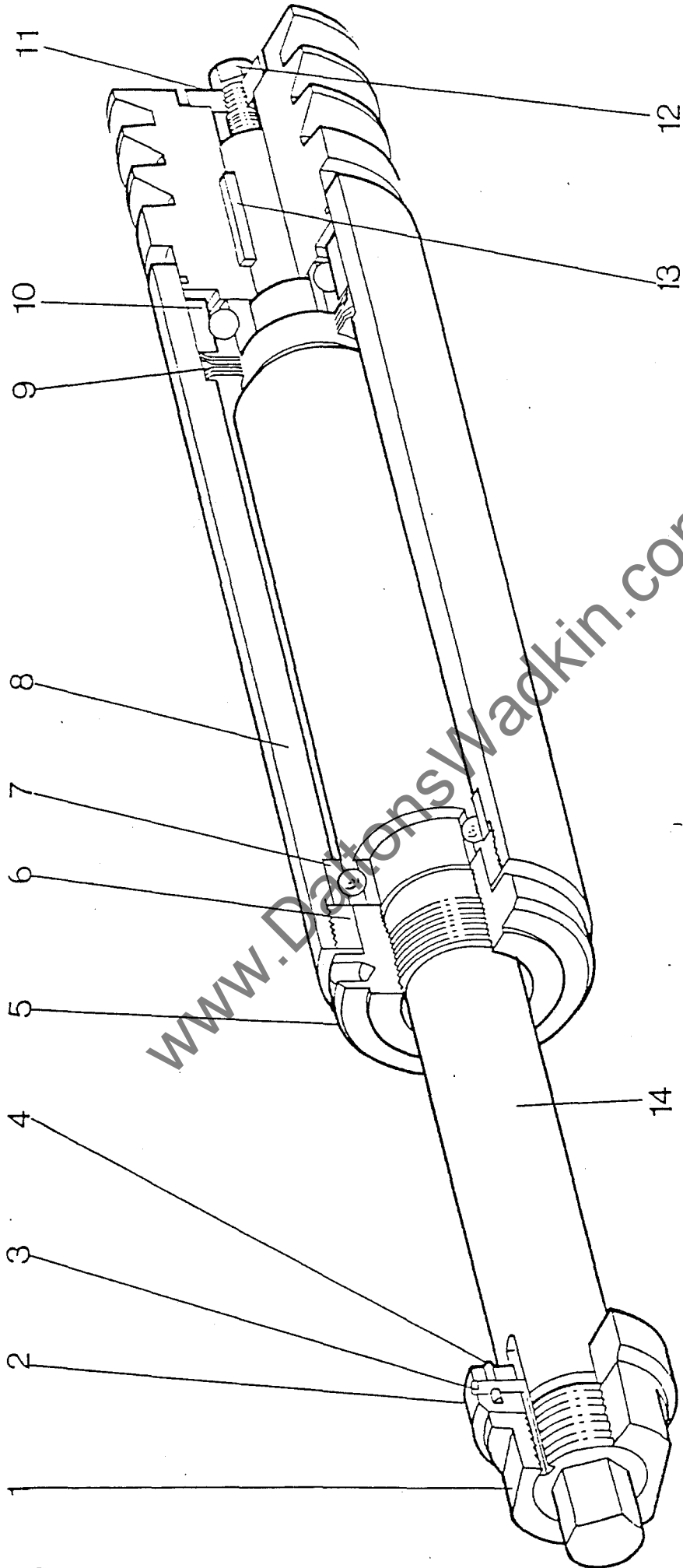

UNIVERSAL HEAD SPINDLE 40mm DIAMETER SQUARE SHOULDER

VARIABLE SPEED DRIVE (WITH RIGHT ANGLED ADJUSTER) - SIZE 16 (GEAR DRIVEN FEED WORKS)

DESCRIPTION	"SIMPLABELT" TYPE	NO:OFF
Motor pulley	11.213.16.911	1
Spring loaded pulley	11.213.16.920	1
Right angled pulley adjuster	11.230.16.932	1
Vee belt	NO: 28/800	1

INTERMEDIATE VEE BELT DRIVE - GEAR DRIVEN FEEDWORKS

Driving pulley		1
Driven pulley		1
Vee belts - SPZ 1010		4

VARIABLE SPEED DRIVE - SIZE 20 (GEAR DRIVEN FEEDWORKS)

DESCRIPTION	"SIMPLABELT" TYPE	NO:OFF
Motor pulley - adjustable	11.213.20.911	1
Spring loaded pulley	11.213.20.920	1
Pulley adjuster	11.213.20.932	1
Vee belt	NO: 37/900	1

INTERMEDIATE VEE BELT DRIVE - GEAR DRIVEN FEEDWORKS

Driving pulley		1
Driven pulley		1
Vee belts - SPZ 1010		4

www.DaltonsWadkin.com

BEARINGS AND SEALS

FEEDWORKS DRIVE SHAFT		NO:OFF
R.H.P. OR SKF. 6006 - 2RS		2
FEEDROLL SWINGS		
R.H.P. OR SKF. 6006 - 2RS		2
GEARBOX		
R.H.P. OR SKF. 6006		4
R.H.P. OR SKF. 6006 - 2RS		6
R.H.P. OR SKF. 51104	Thrust bearing	2
R.H.P. OR SKF. 51106	Thrust bearing	2
D.P.S.M 25407	"GACO" oil seal	2
W.R.826	"WESTON" oil seal	2
W.R.828 (Infeed box only)	"WESTON" oil seal	1
D.P.S.M 25407	"GACO" oil seal	2
D.P.S.M 20307	"GACO" oil seal	1
CHAIN DRIVE HUB TO BOTTOM FEED ROLL		
R.H.P. OR SKF. 6206-2RS		2
DRIVE CHAIN TO BOTTOM FEED ROLL		
15.875 pitch - Simple	"RENOLD" 110 056	57 pitches
Connecting link - Single No: 25		1

PROCEDURE FOR FITTING SAFETY DRIVE COLLARS FOR HYDROFIX CUTTER-BLOCKS AND HYDROGRIP SLEEVES

1) Threaded Safety Collar

For use when full length tooling is in use on the machine spindle.

- 1.1 The cutterblock or sleeve is mounted onto the machine spindle in the normal manner, making sure that they fit flush up to the shoulder, at the motor end.
- 1.2 Pressurisation now takes place to the correct load required.
- 1.3 The pins in the threaded safety collar should now be unscrewed to the full extent using the knurled heads. Allow the pins to come flush with the face of the collar.
- 1.4 The collar is then screwed onto the spindle to a finger tight position up against the end face of the tooling.
- 1.5 By reversing the direction of the collar on the threads the pins should be brought into line with corresponding holes provided in the end face of the tooling.
- 1.6 When in line the pins are screwed into position, locating them into the corresponding holes in the tooling.
- 1.7 A spacing collar is provided for use in certain conditions when a space is left between the tooling and the safety collar. If required this should be fitted prior to fitting the safety drive collar.
- 1.8 Using an allen key, tighten up the allen cap screw in the collar, which allows the collar to grip the threads on the spindle.
- 1.9 The collar will now maintain the drive to the tooling in the event that pressurisation has not taken place.

Follow the reverse of this procedure to release the tooling from the machine spindle.

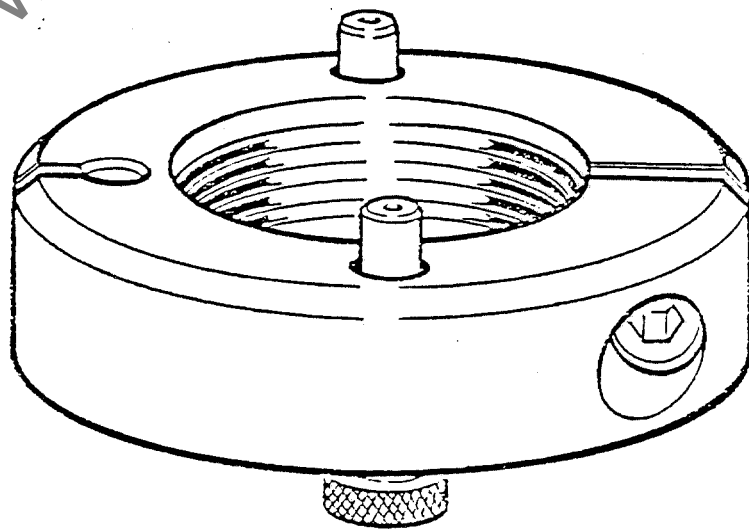

USE OF HYDROGRIP EQUIPMENT.

Hydrogrip cutter equipment is used on planing and moulding machines in order to provide an improved surface finish/higher feed speeds.

In order to protect both the hydrofix cutterblock and the machine spindle it is necessary for safety drive collars to be used with this type of hydrofix equipment.

The consequence of not using the prescribed safety drive collars will result in the cutterblock seizing on the machine spindle in the event of:-

- a) The operator neglecting to pressurise the cutterblock and then running the spindle.
- b) The hydrofix cutterblock/sleeve leaking.

If a seizure occurs, the spindle and cutterblock must be returned to Wadkin Plc for repair, and the appropriate charge will be made for this service.

PROCEDURE FOR FITTING SAFETY DRIVE COLLARS FOR HYDROFIX CUTTER-BLOCKS AND HYDROGRIP SLEEVES

2) Plain Safety Collar

For use when short length tooling is in use on the machine spindle.

2.1 *The cutterblock or sleeve is mounted onto the machine spindle in the normal manner, making sure that they fit flush up to the shoulder, at the motor end.*

2.2 *Pressurisation now takes place to the correct load required.*

2.3 *The collar is with its pins facing the tooling is now slid along the machine spindle up against the face of the tooling, with the pins located in corresponding holes provided in the end face of the tooling.*

2.4 *Using an allen key, tighten up the allen cap screw in the collar, which allows the collar to grip the machine spindle.*

2.5 *The collar will now maintain the drive to the tooling in the event that pressurisation has not taken place.*

Follow the reverse of this procedure to release the tooling from the machine spindle.

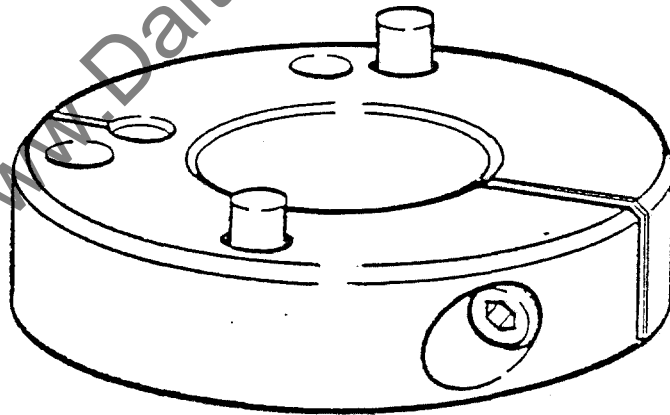

M/C TYPE	THREADED /PLAIN BORE	HEAD	PART NO	PRICE £
170B/220B	RH	Fence/Top	MMT 2552	
40mm dia bore	LH	Near/Bottom	MMT 2554	
For H/fix blocks	Plain	All	MMT 2560	
GA 170+	RH	Fence/Top	MMT 2556	
220 40mm dia bore	LH	Near/Bottom	MMT 2558	
For H/fix blocks	Plain	All	MMT 2560	
XJ 220 40mm Ø bore for H/fix blocks	As for GA 170/220			
'B' range moulder with 50 dia spindles for H/fix blocks	RH	Fence/Top	MMT 2572	
	LH	Near/Bottom	MMT 2574	
	Plain	All	MMT 2576	
FBP machine with 50mm dia spindles For H/fix blocks H/fix sleeves	As above for 'B' range			
FBP machine with 1.13/16 dia spindles For H/fix blocks or sleeves	Plain all		MMT 2578	
170B/220B 40mm dia bore for H/fix sleeves	RH	Fence/Top	MMT 2564	
	LH	Near/Bottom	MMT 2566	
	Plain	All	MMT 2562	
GA 170/220 or XJ 220 40mm dia bore for H/fix sleeves	RH	Fence/Top	MMT 2568	
	LH	Near/Bottom	MMT 2570	
	Plain	All	MMT 2562	

ALWAYS QUOTE MODEL, MACHINE NO: AND SECTION NO: WHEN ORDERING SPARES

BOTTOM HEAD SPINDLE UNIT 40MM. DIA. SQUARE SHOULDER

REF.NO:	DESCRIPTION	NO: OFF
1	Locking nut for Bottom Head and Near Side head spindles	1
2	40mm. dia. square shoulder Bottom Head spindle	1
3	Bearing nut for Bottom Head and Near Side head spindles	1
4	Bearing nut for spindle housing	1
∅ 5	R.H.P. OR SKF. Bearing 7009 TDUF-EP7 (paired bearings)	2 sets
6	Barrel for Horizontal and Side Head spindle	1
7	8mm. x 7mm. x 40mm. long key	1
8	Pulley spigot for spindle	1
9	M12. x 45mm. long hexagonal head screw	1
10	Outer bearing spacer	2
11	Inner bearing spacer	2

∅ "KLUBER" grease packed

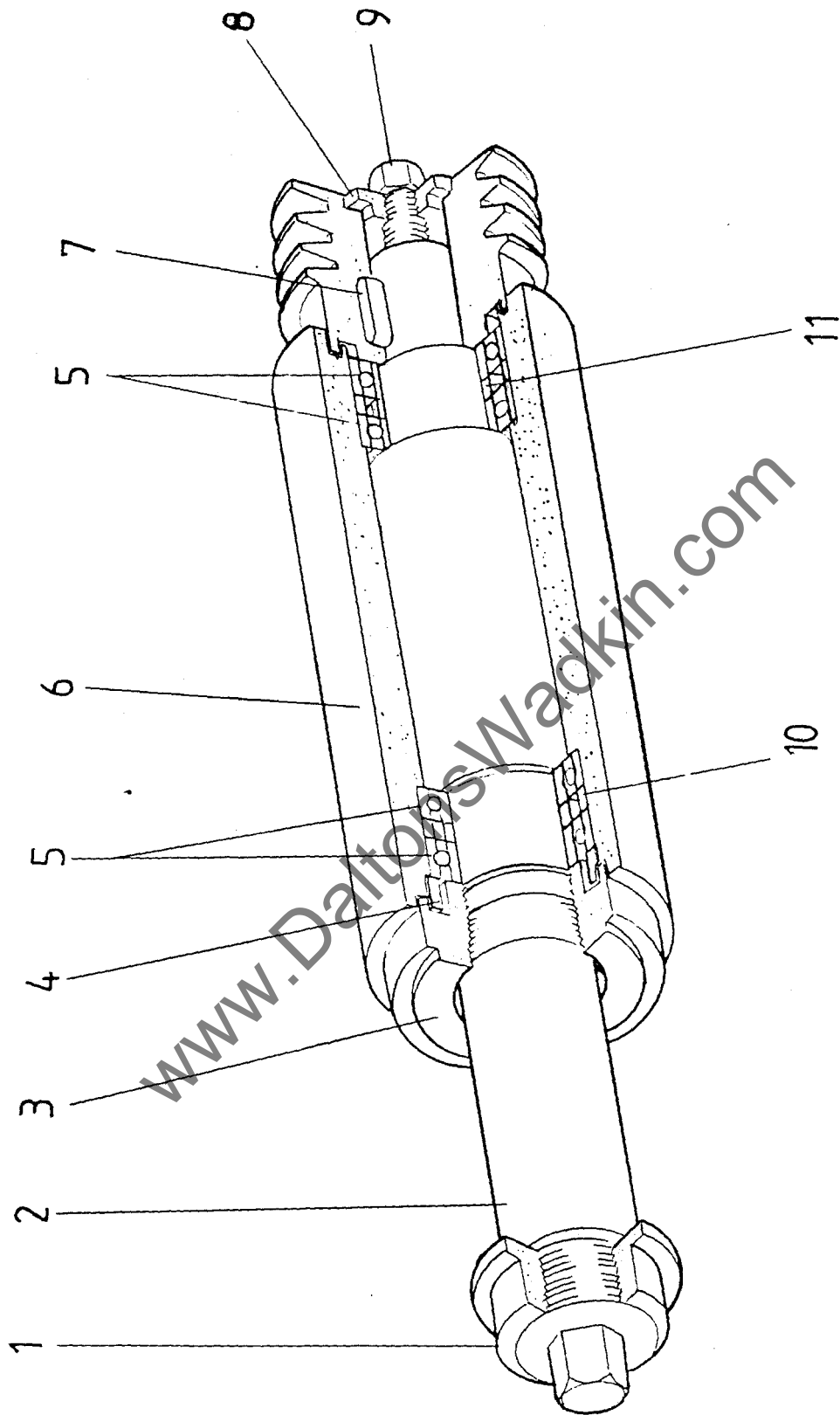

BOTTOM HEAD SPINDLE UNIT 40mm DIA SQUARE SHOULDER
WITH PRECISION BEARINGS

ALWAYS QUOTE MODEL, MACHINE NO: AND SECTION NO: WHEN ORDERING SPARES

FENCE SIDE HEAD SPINDLE UNIT 40MM. DIA. SQUARE SHOULDER

REF.NO:	DESCRIPTION	NO:OFF
1	Locking nut for Fence Side head, Top head and Universal head spindles	1
2	Bearing nut for Fence Side head, Top head and Universal head spindles	1
3	Bearing nut for spindle housing	1
∅ 4	R.H.P. OR SKF. bearing 7009 TDUF-EP7 (paired bearings)	2 sets
5	Barrel for Horizontal and Side head spindle	1
6	Pulley spigot for spindle	1
7	M12. x 35mm. long hexagon head screw	1
8	8mm. x 7mm. x 40mm. long key	1
9	Outer bearing spacer	2
10	Inner bearing spacer	2
11	40mm. dia. square shoulder Fence Side head spindle	1

∅ "KLUBER" greased packed

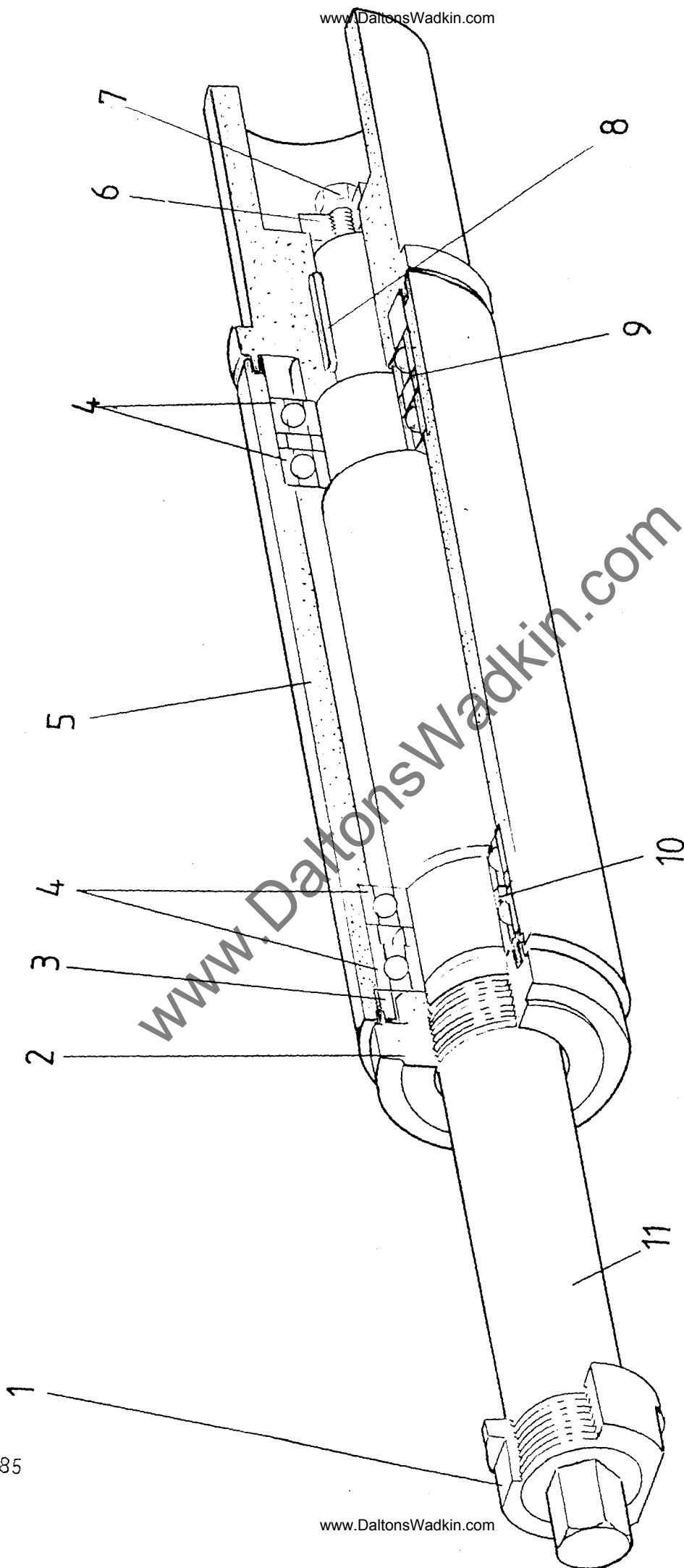

FENCE SIDE HEAD SPINDLE UNIT 40mm DIAMETER SQUARE SHOULDER
WITH PRECISION BEARINGS

May, 1985

ALWAYS QUOTE MODEL, MACHINE NO: AND SECTION NO: WHEN ORDERING SPARES
NEAR SIDE HEAD SPINDLE UNIT 40MM. DIAMETER SQUARE SHOULDER

REF.NO:	DESCRIPTION	NO:OFF
1	Locking nut for Bottom head and Near Side head spindles	1
2	Bearing nut for Bottom head and Near Side head spindles	1
3	Bearing nut for spindle housing	1
∅ 4	R.H.P. OR SKF. Bearing 7009 TDUF-EP7 (paired bearings)	2 sets
5	Barrel for Horizontal and Side head spindle	1
6	Pulley spigot for spindle	1
7	M12. x 35mm. long hexagonal head screw	1
8	8mm. x 7mm. x 40mm. long key	1
9	Outer bearing spacer	2
10	Inner bearing spacer	2
11	40mm. dia. square shoulder Near Side head spindle	1

∅ "KLUBER" grease packed

May, 1985

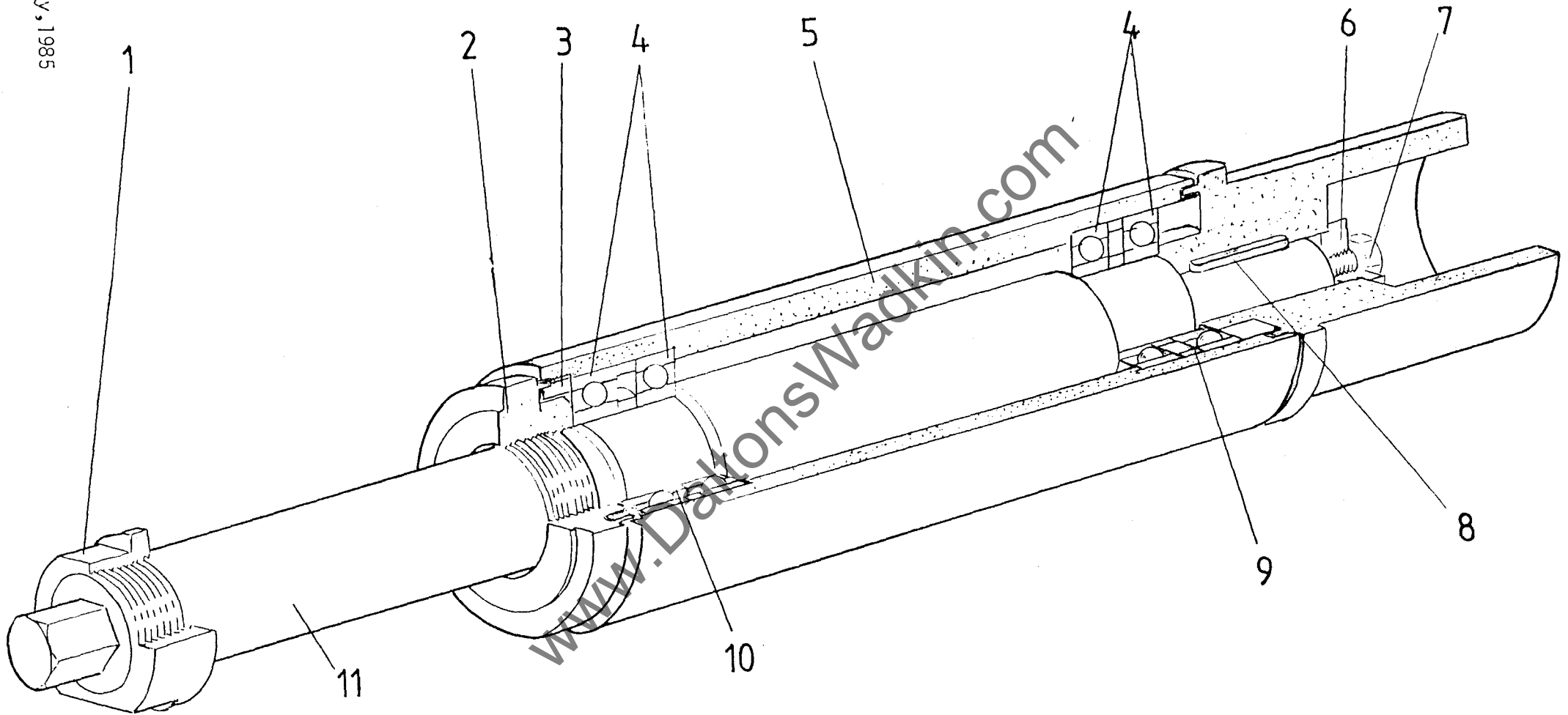

NEARSIDE HEAD SPINDLE UNIT 40mm DIAMETER SQUARE SHOULDER
WITH PRECISION BEARINGS

ALWAYS QUOTE MODEL, MACHINE NO: AND SECTION NO: WHEN ORDERING SPARES

TOP HEAD SPINDLE UNIT 40MM. DIA. SQUARE SHOULDER

REF.NO:	DESCRIPTION	NO:OFF
1	Locking nut for Fence Side head, Top head, Universal head spindles	1
2	40mm. dia. square shoulder top head spindle	1
3	Bearing nut for Fence Side, Top head and Universal head spindles	1
4	Bearing nut for spindle housing	1
∅ 5	R.H.P. OR SKF bearing 7009 TDUF-EP7 (paired bearings)	2 sets
6	Barrel for Horizontal and Side head spindle	1
7	8mm. x 7mm. x 40mm. long key	1
8	Pulley spigot for spindle	1
9	M12. x 45mm. long hexagonal head screw	1
10	Outer bearing spacer	2
11	Inner bearing spacer	2
∅	"KLUBER" grease packed	

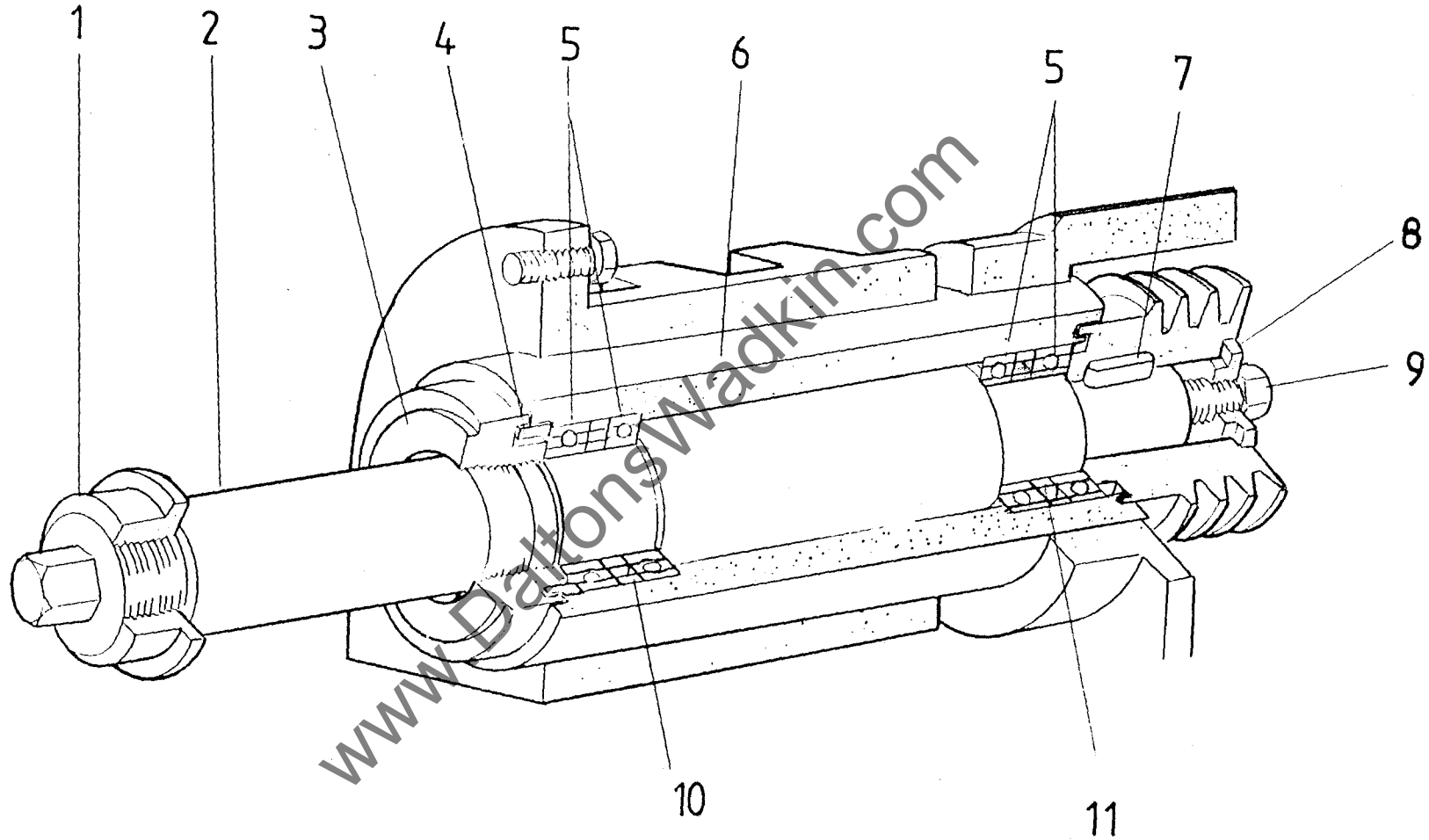

TOP HEAD SPINDLE UNIT 40mm DIA SQUARE SHOULDER
WITH PRECISION BEARINGS

STOCK RECORDER

OPERATION;-

The counter counts from ZERO to a preset figure when a changeover contact operates and stops the feed. This is indicated by a red light.

The feed cannot be started until the counter has been reset.

SETTING INSTRUCTIONS

1. Insert the reset key into the plunger at the left side of the top display.
2. Press the key in, the top scale will now be ZEROED.
3. Press plungers to index counter to the required amount. (If the amount required is same as the previous setting the indexing plungers need not be pressed).
4. Remove key.
5. The feed will now start.