



ULTRACARE
At the Cutting Edge of Industry

CP RANGE

SLIDING TABLE

PANEL SAWS

INSTRUCTION MANUAL No.3026



CP RANGE

SLIDING TABLE

PANEL SAWS

MACHINE No.	
TEST No.	
YEAR OF MANUFACTURE	

**MANUFACTURERS E.C. DECLARATION
OF CONFORMITY**

The following machine has undergone "Conformity Assessment" and has undergone Third Party Examination by a Notified Body in accordance with:-

Schedule IV of the Supply of Machinery (Safety) Regulations 1992 and Amendment No. 2063

COMPANY

Wadkin Ultracare Limited
Franks Road
Hilltop Industrial Park
Bardon
Leicestershire
LE67 1TT

RESPONSIBLE PERSON

Mr J P Smith (Director)

MACHINE DESCRIPTION

TYPE Sliding Table Panel Saw

MODEL CP Range

DIRECTIVES COMPLIED WITH

Supply of Machinery (Safety) Regulations 1992
Amendment No. 2063 1994
Draught Proposal CEN/TC 142
ISO 9001 Part 1

NOTIFIED BODY

Lloyds Register
Lloyds Register House
29 Wellesley Road
Croydon, CR0 2AJ

SIGNED ON BEHALF OF WADKIN
ULTRACARE LTD.

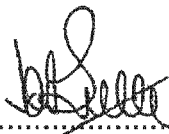

EC TYPE EXAMINATION
CERTIFICATE NO.

EC94/00010



EC Type Examination Certificate

Certificate Number: EC 94/00010 A1

Office: UK Industry – Statutory Services

Date: 23 December 1994

*This is to certify that Lloyd's Register of Shipping, an Approved Body under the terms of:
The Machinery Directive 89/392/EEC as amended by Directives 91/368/EEC, 93/44/EEC and
93/68/EEC as consolidated by Directive 98/37/EC.*

*The Supply of Machinery (Safety) Regulations 1992, Statutory Instrument 1992 No. 3073 as amended
by Statutory Instrument 1994 No. 2063*

*did undertake an EC Type Examination on the stated product for compliance with the essential safety
requirements of the Directive. The product identified below was shown to comply.*

This certificate is issued to

APPLICANT Wadkin Ultracare Limited,
Green Lane Road,
Leicester LE5 4PF,
England.

**PRODUCT
DESCRIPTION** Sliding Table Panel Saws

TYPE CP Range: CP320, CP260, CP160

*The attached LR Design Appraisal Document No. EC94/00010 issue 2 details the content of the
Technical Construction File and shall form a part of this certificate.*

*"This Certificate is not valid for equipment, the design, ratings or operating parameters of
which have been varied from the specimen tested. The manufacturer should notify LR of any
modification or changes to the equipment in order to obtain a valid certificate."*

M.R. GREENHALGH
Surveyor to Lloyd's Register

LR EC Distinguishing Number 0038

**BE CAREFUL
THIS MACHINE CAN BE DANGEROUS
IF IMPROPERLY USED**

Always use guards.
Keep clear until rotation has ceased.
Always operate as instructed
and in accordance with good practice.
Read instruction manual before installing,
operating or maintaining machine.

*Manufactured by : Wadkin UltraCare
Franks Road
Hilltop Industrial Park
Bardon
Leicestershire, LE67 1TT
United Kingdom*

*Telephone No. : +44(0)870 850 9111
Fax No. : +44(0)870 240 0575
Website : www.wadkinultracare.com
E mail : info@wadkinultracare.com*



PREFACE

IMPORTANT

IT IS OUR POLICY AND THAT OF OUR SUPPLIERS TO CONSTANTLY REVIEW THE DESIGN AND CAPACITY OF OUR PRODUCTS. WITH THIS IN MIND WE WOULD REMIND OUR CUSTOMERS THAT WHILE THE DIMENSIONS AND PERFORMANCE DATA CONTAINED HEREIN ARE CURRENT AT THE TIME OF GOING TO PRESS, IT IS POSSIBLE THAT DUE TO THE INCORPORATION OF THE LATEST DEVELOPMENTS TO ENHANCE PERFORMANCE, DIMENSIONS AND SUPPLIERS MAY VARY FROM THOSE ILLUSTRATED

THIS MANUAL IS WRITTEN AS A GENERAL GUIDE. A TYPICAL MACHINE IS SHOWN TO ILLUSTRATE THE MAIN FEATURES.

Failure to comply with instructions in this book may invalidate the guarantee

IMPORTANT

SAFETY PROCEDURES AND CONSIDERATIONS

To ensure safe working conditions, persons operating and assisting with the operation of this machine must ensure that they read and fully understand the instructions given within this manual and have received sufficient training in the use of the machine and the safety aspects to be observed.

Note:- Persons under the age of 18 years must not operate the machine except during a course of training under the supervision of a trained operator.

A) POINTS TO NOTE BEFORE OPERATING OR ASSISTING WITH THE OPERATION OF THE MACHINE

- 1) You have read and understood the operation and safety aspects of the machine and have been checked out by a qualified supervisor.
- 2) The machine is supplied with full safeguarding. The machine shall not be operated unless the safeguardings are in position and functional.
- 3) Cutters/blades are the correct type, suitable for the machine and working conditions, rotate in the correct direction of cut, are sharp and correctly fitted.
- 4) Correct spindle and speeds are selected for the cutter equipment and working conditions.
- 5) Loose clothing is either removed or securely fastened back and jewellery removed.
- 6) Adequate working space and lighting is provided.
- 7) All dust extraction equipment is switched on, properly adjusted and working adequately.
- 8) The machine is securely installed (refer to installation section within this manual).
- 9) The machine should only be used for cutting wood or materials with physical and technological characteristics similar to wood, and for which the chip or particle removal process is similar.



B) DURING MACHINING:-

- 1) Wear suitable protective clothing e.g., approved eye protection, ear defenders and dust mask. Gloves shall be worn when handling sharp edged saws.
- 2) Stop the machine using the emergency stop or at the mains isolator before making adjustments, cleaning or carrying out maintenance.
- 3) Keep the floor area around the machine clean and free from wood refuse. Do not allow the floor around the machine to become slippery.
- 4) Stop the machine and report immediately to a person in authority any actual or potential malfunction or operator hazard. Do not attempt to repair or rectify the machine unless qualified and authorised to do so.
- 5) The operator must not leave the machine running whilst unattended.
- 6) Never by pass interlocks.
- 7) A push stick or handled push block must be used to feed the trailing end of a workpiece past the cutting head.
- 8) When ripping never stand directly behind the material.

WARNING:-

Failure to observe correct operating procedures prior to and during operation of this machine can result in severe injury.

DO NOT attempt to operate the machine while under the influence of anything that reduces your alertness.

HEALTH AND SAFETY

The CE mark on this machine signifies that an EC Declaration of Conformity is drawn up indicating that the machine is manufactured in accordance with the Essential Health and Safety Requirements of the 'Supply of Machinery (Safety) Regulations 1992'.

The 'requirements for supply of relevant machinery' in the General Requirements of the Regulations are not only that the machine satisfies the relevant essential health and safety requirements, but also that 'the manufacturer.....carries out the necessary research or tests on components, fittings or the complete machine to determine whether by its design or construction the machine is capable of being erected and put into service safely'.

Persons who install this machine have duties under the 'Provision and Use of Work Equipment Regulations 1992'. An indication of these duties is given in the following extracts, but the user should be familiar with the full implications of the regulations.

REGULATION 5 requires that:

Every employer shall ensure that work equipment is so constructed or adapted as to be suitable for the purpose for which it is used or provided.

In selecting work equipment, every employer shall have regard to the working conditions and to the risks to health and safety of persons which exist in the premises or undertakings in which that work equipment is to be used and any additional risk posed by the use of that work equipment.

Every employer shall ensure that work equipment is used only for the operations for which, and under conditions for which, it is suitable.

In this regulation 'suitable' means suitable in any respect which it is reasonably foreseeable will affect health or safety of any person.

The Provision and Use of Work Equipment Regulations also include requirements as follows.

regulation 6 - maintenance,

regulation 7 - specific risks,

regulation 8 - information and instructions,

regulation 9 - training.

Note:-

Attention is drawn to those requirements of the 'Woodworking Machines Regulations 1974' which are not replaced by the Supply of Machinery (Safety) Regulations or other, eg; Regulation 13 of the Woodworking Machinery Regulation, - 'Training', still applies.

Whilst the prime duty for ensuring health and safety rests with employers, employees too have legal duties, particularly under sections 7 and 8 of the Health and Safety at Work Act. They include:

taking reasonable care for their own health and safety and that of others who may be affected by what they do or don't do;

co-operating with their employer on health and safety;

not interfering with or misusing anything provided for their health, safety and welfare.

These duties on employees have been supplemented by regulation 12 of the Management of Health and Safety at Work Regulations 1992. One of the new requirements is that employees should use correctly all work items provided by their employer in accordance with their training and the instructions they receive to enable them to use the items safely.



Noise

Noise levels can vary widely from machine to machine depending on the conditions of use. Persons exposed to high noise levels, even for a short time, may experience temporary partial hearing loss and continuous exposure to high levels can result in permanent hearing damage.

The Noise at Work Regulations 1989 place legal duties on employers to prevent damage to hearing.

There are three action levels of noise defined in regulation 2;

the first action level:-

a daily personal noise exposure (LEP,d) of 85dB(a)

the second action level:-

a daily personal noise exposure (LEP,d) of 90dB(A)

the peak action level

a peak sound pressure of 200 pascals (140dB re 20pa)

The exposure level is obviously influenced by the emission level of all the equipment in use.

Emission levels for machines are provided in the particular machine instruction book.

These levels are measured in accordance with ISO 7960 under certain specified test conditions, they do not necessarily represent the highest noise level, which is influenced by many factors, eg number of spindles in operation, type and condition of workpiece, spindle speeds etc.

For regulations and information on relevant personal protective equipment i.e., ear defenders, employers should refer to the Personal Protective Equipment at Work Regulations 1992.

Dust

Wood dust can be harmful to health by inhalation and skin contact and concentrations of small particles in the air can form an explosive mixture.

The Control of Substances Hazardous to Health Regulations (COSHH) 1989 place legal duties on employers to ensure that:

the exposure of his employees to substances hazardous to health is either prevented or, where this is not reasonably practicable, adequately controlled.

...adequate control to exposure of employees to a substance hazardous to health shall be secured by measures other than the provision of personal protective equipment.

where the measures taken in accordance with the paragraph above do not prevent or provide adequate control of, exposure to substances hazardous to the health of employees, then, in addition to taking those measures, the employer shall provide those employees with such suitable personal protective equipment as will adequately control their exposure to substances hazardous to health.

Instructions for Use

Machinery manufacturers are required by the Supply of Machinery Safety Regulations to provide comprehensive 'Instructions for Use' of equipment, it is important that this information is transmitted to the person using the machine.



CONTENTS

SECTION 1	GENERAL INFORMATION	Page
	General notes	1-1
	Operator working stations	1-1
	Noise emission values	1-2
	Foundation and machine dimensions	1-4
	Machine specifications	1-5
	Machine main components	1-9
	Electrical wiring diagrams	1-11
SECTION 2	UNLOADING, UNPACKING, AND INSTALLATION	
	Unloading	2-1
	Unpacking :-	2-1
	Cleaning	2-2
	Installation :-	2-2
	Location and foundation	2-2
	Electrical supplies	2-2
	Exhaust connections	2-3
	Machine re-assembly	2-3
SECTION 3	OPERATING INSTRUCTIONS	
	General information	
	Safety	3-1
	Safety devices	3-1
	Controls	3-1
	Mounting the saws	
	Main saw fitting / replacement	3-3
	Scoring saw fitting / replacement	3-4
	Machine adjustments	
	Crown guard adjustment / changing	3-7
	Main saw adjustment	3-7
	Scoring saw adjustment	3-8
	Riving knife adjustment	3-9
	Speed adjustment	3-9
	Rip fence	3-10
	Crosscut fence, Outrigger table and Turnover stop	3-11
	Sliding table	3-13



SECTION 4

MAINTENANCE

Lubrication	4-1
Belt tension checking / adjustment for main saw drive	4-2
Belt tension for scoring saw	4-2
Brake motor maintenance	4-2
Cleaning	4-3
Fault finding	4-4
Recommended lubricants	4-5

SECTION 5

ILLUSTRATED PARTS LIST

Main saw spindle	5-3
Scoring saw spindle	5-5
Scoring saw adjustment and swing	5-7
Main saw rise and fall assembly	5-9
Canting mechanism assembly	5-11
Riving knife assembly	5-13
Sliding table	5-15
Turnover stops	5-17
Manual clamp	5-19
Handles and lock for sliding table	5-21
Motor mounting and swings	5-23

SECTION 1 GENERAL INFORMATION

The CP range of panel saws comprise of three models CP160, CP260 and CP320.

The working of the machine is generally a one man operation although an assistant is usually necessary to off load the material when ripping.

As well as the main saw all models come complete with an independently driven scoring saw. This can only be used in conjunction with the 300mm diameter main saw and rotates in the opposite direction.

The scoring saw makes a shallow cut to the underside of the panel before the main saw cuts through and thus eliminates breakout to bottom face.

The type of work which may be carried out are:-

- a) **Ripping** using rip fence as guide or straight edge ripping using hold down plate.
- b) **Cross cutting** using sliding table and cross cut fence e.g panel sizing or angle cutting with crosscut fence pivoted to suit.
- c) **Angled cutting** with saw blade tilted. The trunnion bracket carrying the saws may cant up to 45 degrees.
- d) **Compound angles.** With the blades canted and the crosscut fence angled intricate compound angles may be cut.

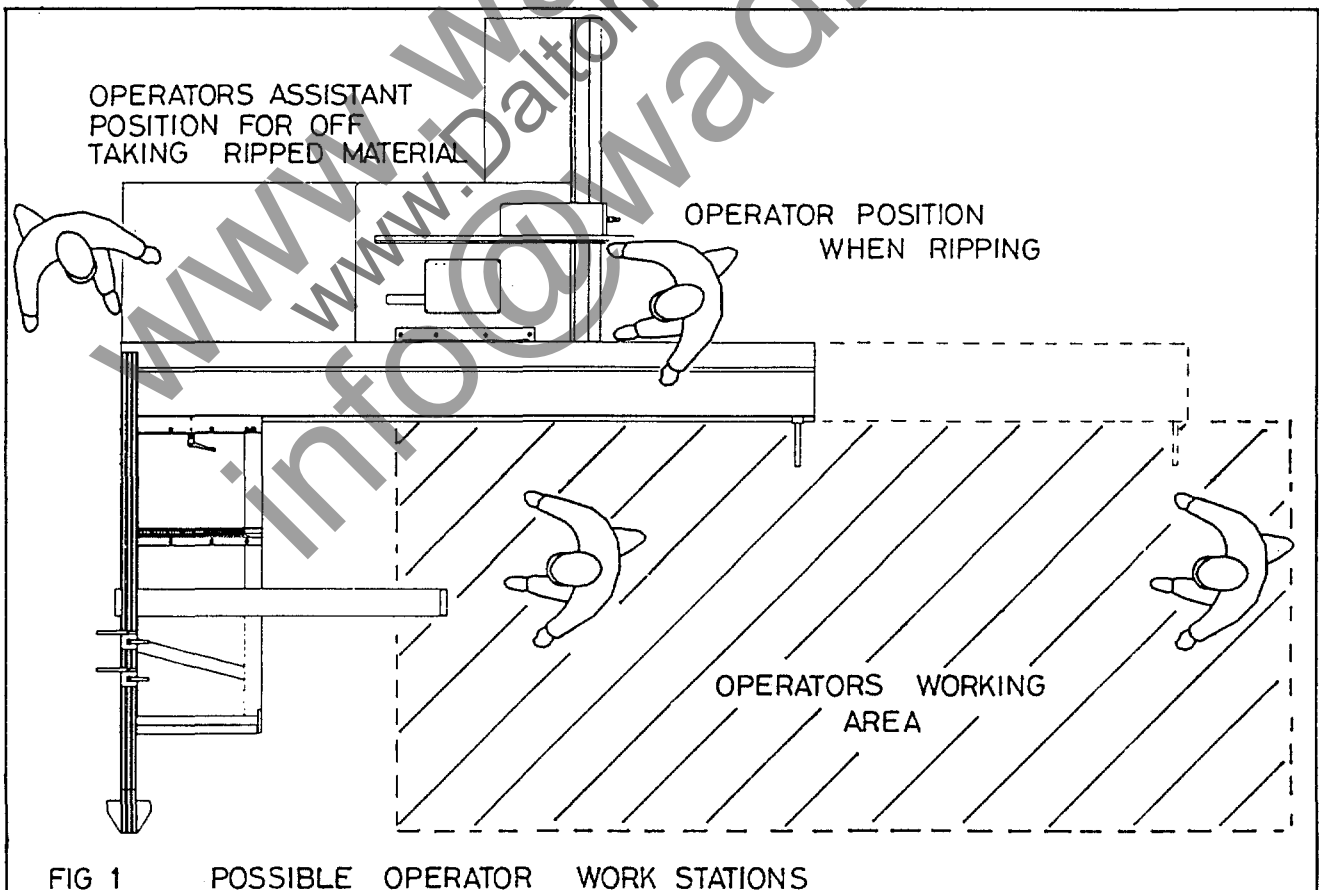

FIG 1 POSSIBLE OPERATOR WORK STATIONS



NOISE EMISSION VALUES

Machine criteria

The machine was free standing on a concrete floor, not bolted down and not mounted on any vibration dampening.

A flexible pipe connected the machine to the dust extraction.

There was no enclosure around the machine.

Machine cutting criteria

The machine was tested twice, once using a 250mm saw blade with 60 teeth and once using a 350mm saw blade with 84 teeth. Both saw blades had carbide tipped teeth a cutting width of 3.2mm and blade thickness of 2.2mm. The blades rotated at 3800 R.P.M.

No scoring saw was used.

Feed rate:- 4-8 M/min

Cut width:- 50mm

Saw blade projection:- 30mm

NOISE EMISSION CHART		
MODEL:- CP TYPE :- CP320	50HZ	415V 250mm saw blade
DECLARED NOISE EMISSION VALUES in accordance with ISO4871		
	Idling	Operating
Declared A-weighted sound power level (L _{WAD}) in dB re l _{pw}	86.95	100.71
Declared A-weighted emission sound level (L _{pAd}) in dB re 20uPa at the operators position	73.7	87.46
Environmental correction factor (K)	= 3	
values determined according to specific test code IS7960 Annex A		

NOISE EMISSION CHART		
MODEL:- CP TYPE :- CP320	50HZ	415V 350mm saw blade
DECLARED NOISE EMISSION VALUES in accordance with ISO4871		
	Idling	Operating
Declared A-weighted sound power level (L _{WAD}) in dB re l _{pw}	93.54	97.711
Declared A-weighted emission sound level (L _{pAd}) in dB re 20uPa at the operators position	80.29	84.46
Environmental correction factor (K)	= 3	
values determined according to specific test code IS7960 Annex A		

Material criteria

Material :- particle board
(3 layer construction)
Moisture content:- 6-10%
Board thickness:- 16mm
Board length:- 800-600mm
processed down
to final width
of 150mm.

Preliminary machining:- none

Tooling criteria

The CP range of panel saws are generally supplied with either a 300mm or 400mm diameter saw blade suitable to fit on a 30mm spindle.

The saw should have a 'pin hole' location.

Only use 400mm diameter saws when the scoring saw is not fitted.

Never exceed the specified maximum speed of the saw blades. Wadkin supplied riving knives are marked as to their saw blade suitability and the operator should ensure that the knife and blade are compatible.

Only tools made in conformity to pr EN847-1 shall be used on the machine.

It should also be noted that H.S.S saw blades may be prohibited by law in certain countries and the operator should ascertain the position on this point.

The figures quoted in the noise emission chart are emission levels and are not necessarily safe working levels

Whilst there is a correlation between emission levels and exposure levels, this cannot be used reliably to determine whether or not further precautions are required to achieve safe working levels.

Factors that influence the actual level of exposure to the work force include the duration of exposure, the characteristics of the work room, sources of noise etc i.e the number of machines and other adjacent processes. also the permissible exposure levels can vary from country to country.

Emission levels, however will enable the user of the machine to make a better evaluation of the 'hazard and risk'.

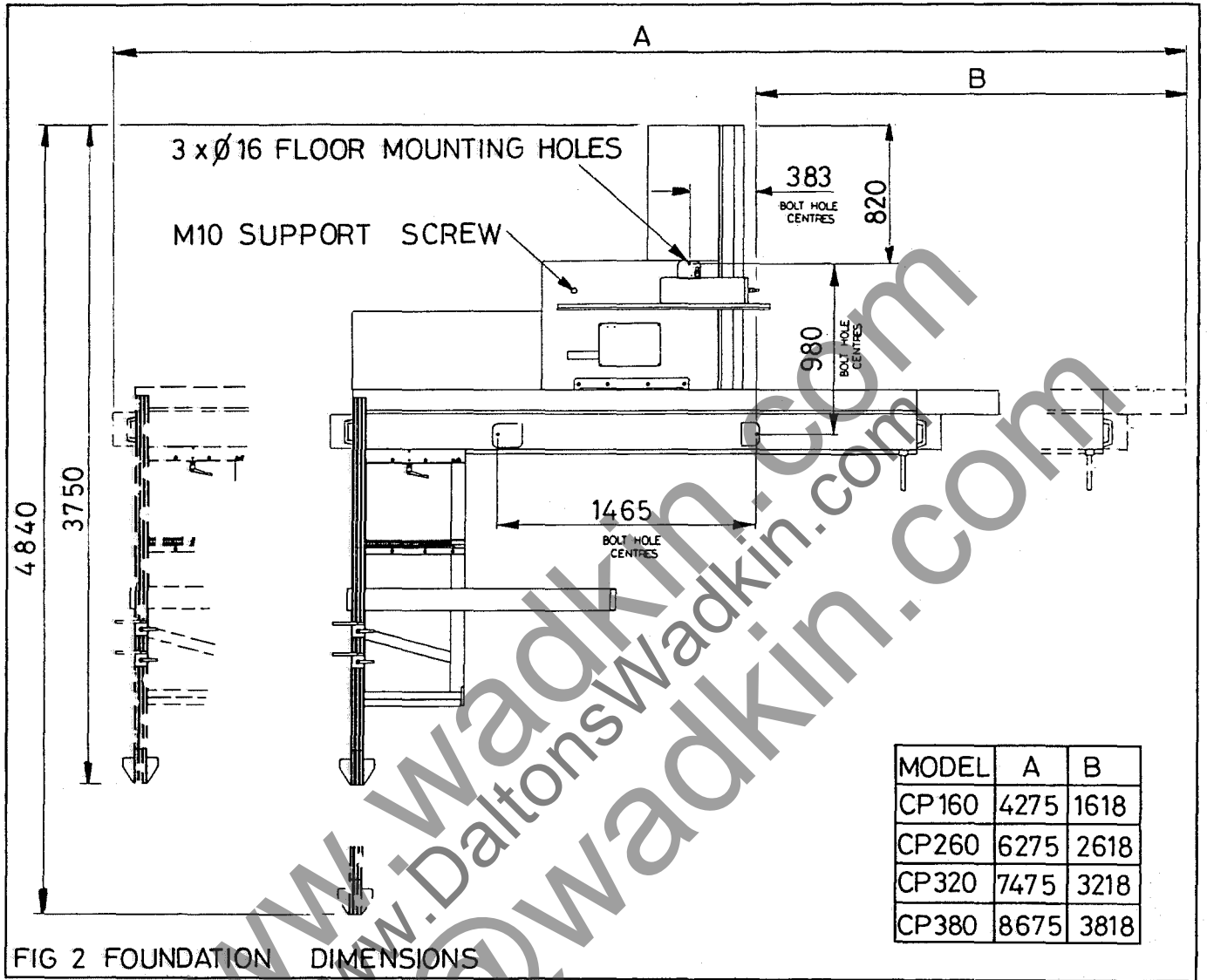

FIG 2 FOUNDATION DIMENSIONS

MACHINE SPECIFICATION CP160

Max panel size	1600mm x 3200mm	(63" x 125")
Sliding table size	340mm x 1600mm	(13 1/4" x 63")
Fixed table size	744mm x 1067mm	(29" x 42")
Max diameter of main saw	400mm	(16")
Max diameter of main saw when scoring	300mm	(12")
Max main saw projection	125mm	(5")
Max scoring saw projection	4mm	(5/32")
Scoring saw diameter	120mm	(4 3/4")
Projection of 300mm main saw at 90 degrees	0-75mm	(0-3")
Projection of 400mm saw at 45 degrees	50-125mm	(2-5")
Main saw spindle diameter	30mm	
Scoring saw spindle diameter	20mm	
Main spindle speeds	2800;3800;4500rpm	
Scoring saw spindle speed	8500rpm	
Main saw motor	5.5KW	(7.5HP)
Main saw motor options	7.5KW	(10HP)
Scoring saw motor	0.55KW	(0.75HP)
Length of cut with sliding table	1600mm	(63")
Distance from saw to stop on cross cut table	3200mm	(125")
Max distance from saw to rip fence	1250mm	(50")
Floor space	3490mm x 4781mm	(137" x 188")
Under saw extraction outlet diameter	100mm	(4")
Crown guard extraction diameter	80mm	(3 5/32")
Total dust extraction rate	1298CM/H	
Air velocity (suitable for timber moisture content of above 18%)	28M/S	
Nett weight approx	810 kg	(1786LBS)
Gross weight approx	1020kg	(2249LBS)

NOTE:- For dry or nearly dry timber i.e moisture content below 18% the air velocity may be reduced to 20 M/S giving a total extraction rate of 927CM/H.



MACHINE SPECIFICATION CP260

Max panel size	2600mm x 3200mm	(102" x 125")
Sliding table size	340mm x 2600mm	(13 1/4" x 102")
Fixed table size	744mm x 1067mm	(29" x 42")
Max diameter of main saw	400mm	(16")
Max diameter of main saw when scoring	300mm	(12")
Max main saw projection	125mm	(5")
Max scoring saw projection	4mm	(5/32")
Scoring saw diameter	120mm	(4 3/4")
Projection of 300mm main saw at 90 degrees	0-75mm	(0-3")
Projection of 400mm saw at 45 degrees	50-125mm	(2-5")
Main saw spindle diameter	30mm	
Scoring saw spindle diameter	20mm	
Main spindle speeds	2800;3800;4500rpm	
Scoring saw spindle speed	8500rpm	
Main saw motor	5.5KW	(7.5HP)
Main saw motor options	7.5KW	(10HP)
Scoring saw motor	0.55KW	(0.75HP)
Length of cut with sliding table	2600mm	(102")
Distance from saw to stop on cross cut table	3200mm	(125")
Max distance from saw to rip fence	1250mm	(50")
Floor space	5491mm x 4781mm	(216" x 188")
Under saw extraction outlet diameter	100mm	(4")
Crown guard extraction diameter	80mm	(3 5/32")
Total dust extraction rate	1298CM/H	
Air velocity (suitable for timber moisture content of above 18%)	28M/S	
Nett weight approx	830 kg	(1830LBS)
Gross weight approx	1070kg	(2359LBS)

NOTE:- For dry or nearly dry timber i.e moisture content below 18% the air velocity may be reduced to 20 M/S giving a total extraction rate of 927CM/H.

MACHINE SPECIFICATION CP320

Max panel size	3200mm x 3200mm	(125" x 125")
Sliding table size	340mm x 3200mm	(13 1/4" x 125")
Fixed table size	744mm x 1067mm	(29" x 42")
Max diameter of main saw	400mm	(16")
Max diameter of main saw when scoring	300mm	(12")
Max main saw projection	125mm	(5")
Max scoring saw projection	4mm	(5/32")
Scoring saw diameter	120mm	(4 3/4")
Projection of 300mm main saw at 90 degrees	0-75mm	(0-3")
Projection of 400mm saw at 45 degrees	50-125mm	(2-5")
Main saw spindle diameter	30mm	
Scoring saw spindle diameter	20mm	
Main spindle speeds	2800,3800,4500rpm	
Scoring saw spindle speed	8500rpm	
Main saw motor	5.5KW	(7.5HP)
Main saw motor options	7.5KW	(10HP)
Scoring saw motor	0.55KW	(0.75HP)
Length of cut with sliding table	3200mm	(125")
Distance from saw to stop on cross cut table	3200mm	(125")
Max distance from saw to rip fence	1250mm	(50")
Floor space	6690mm x 4781mm	(263" x 188")
Under saw extraction outlet diameter	100mm	(4")
Crown guard extraction diameter	80mm	(3 3/52)
Total dust extraction rate	1298CM/H	
Air velocity (suitable for timber moisture content of above 18%)	28M/S	
Nett weight approx	850 kg	(1874LBS)
Gross weight approx	1100kg	(2425LBS)

NOTE:- For dry or nearly dry timber i.e moisture content below 18% the air velocity may be reduced to 20 M/S giving a total extraction rate of 927CM/H.

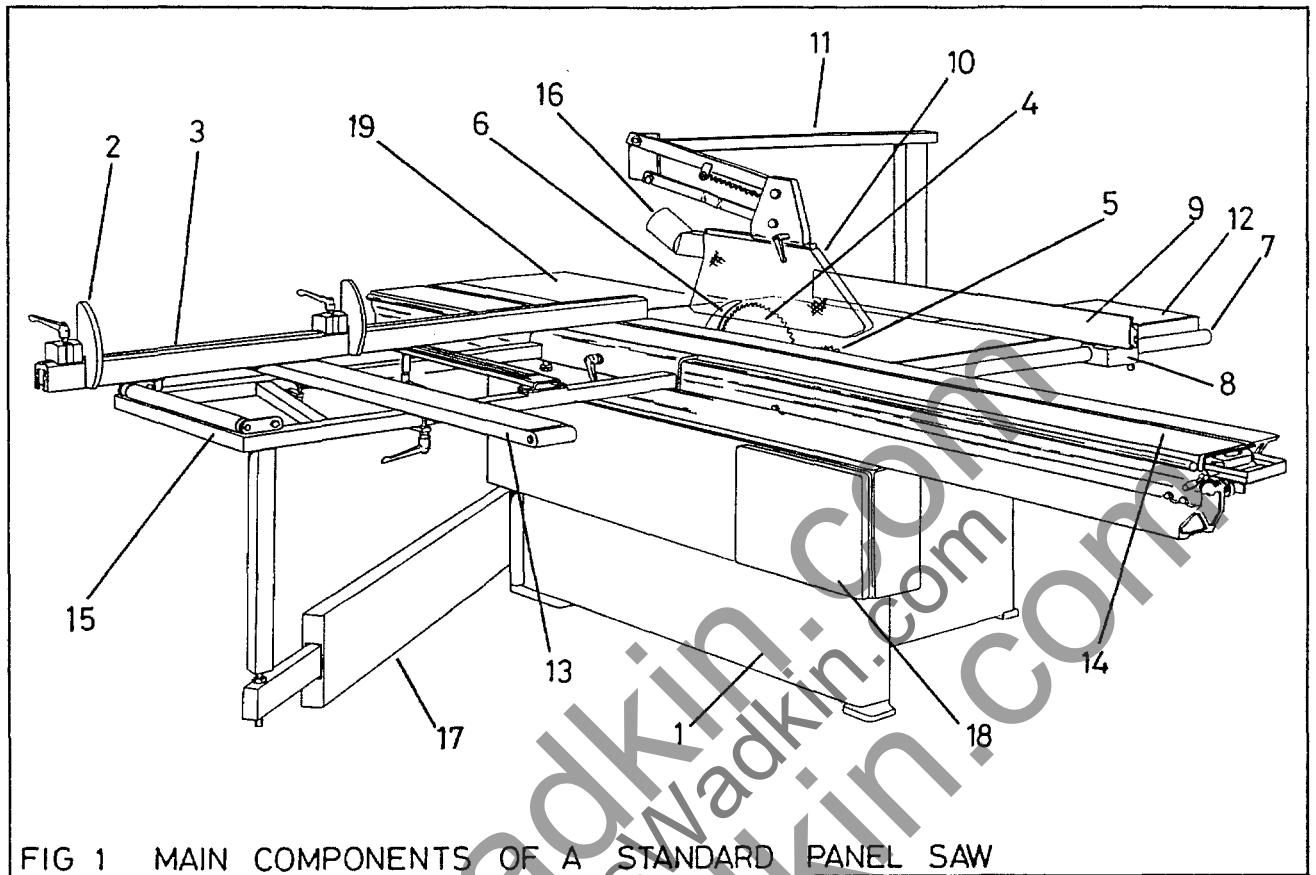
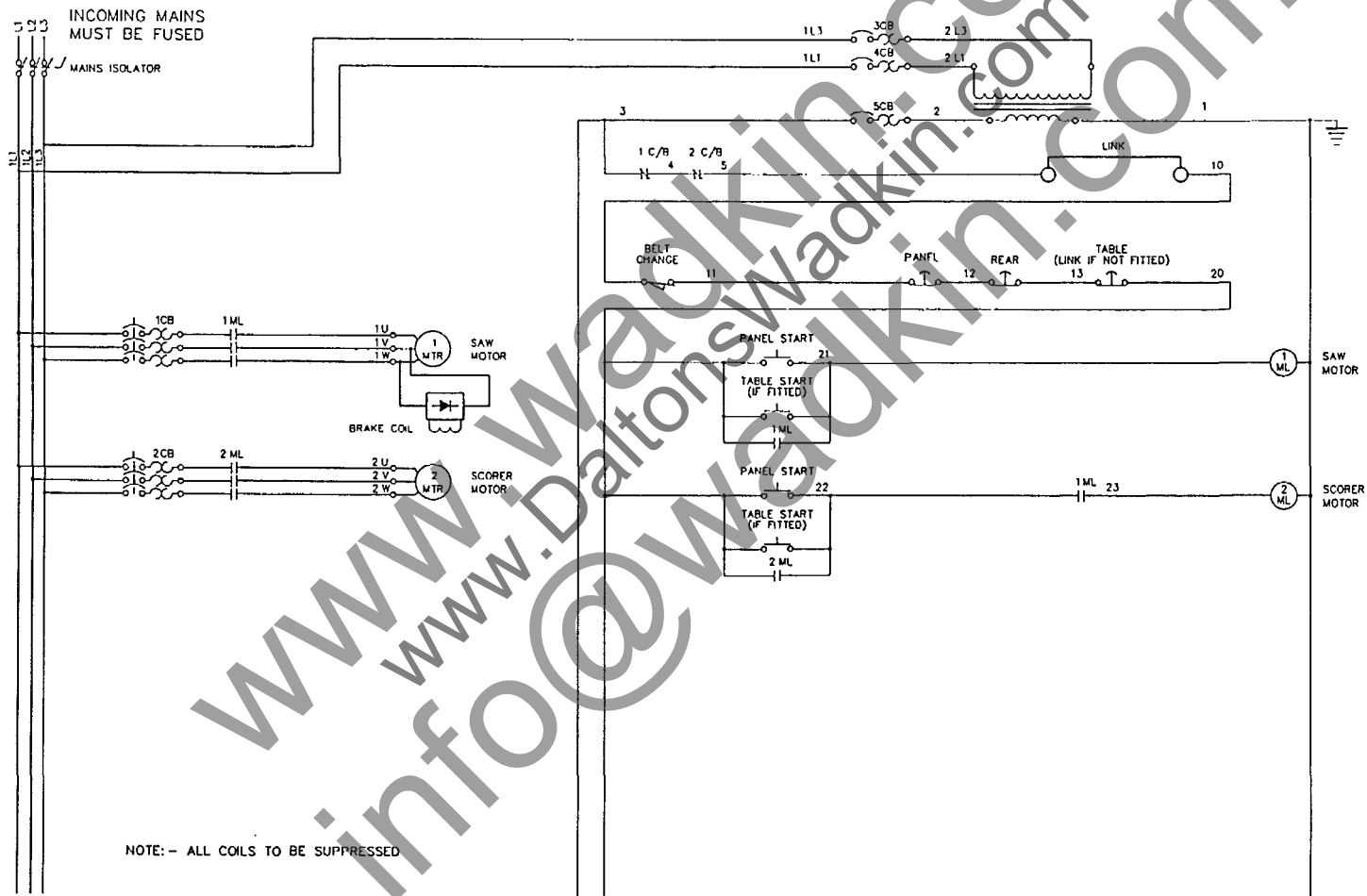

FIG 1 MAIN COMPONENTS OF A STANDARD PANEL SAW

Ref no	Description
1	Main machine body
2	Turnover stops
3	Cross fence
4	Main saw blade
5	Scoring saw blade
6	Riving knife
7	Rip fence guide bar
8	Rip fence body
9	Rip fence
10	Crown guard
11	Crown guard arm
12	Extension table
13	Outer panel support
14	Sliding table
15	Out rigger table
16	Crown guard extraction adaptor
17	Pivot arm extension
18	Control panel
19	Rear extension table



NOTE: - ALL COILS TO BE SUPPRESSED

ELECTRICAL DIAGRAM FOR STANDARD C.E MACHINE

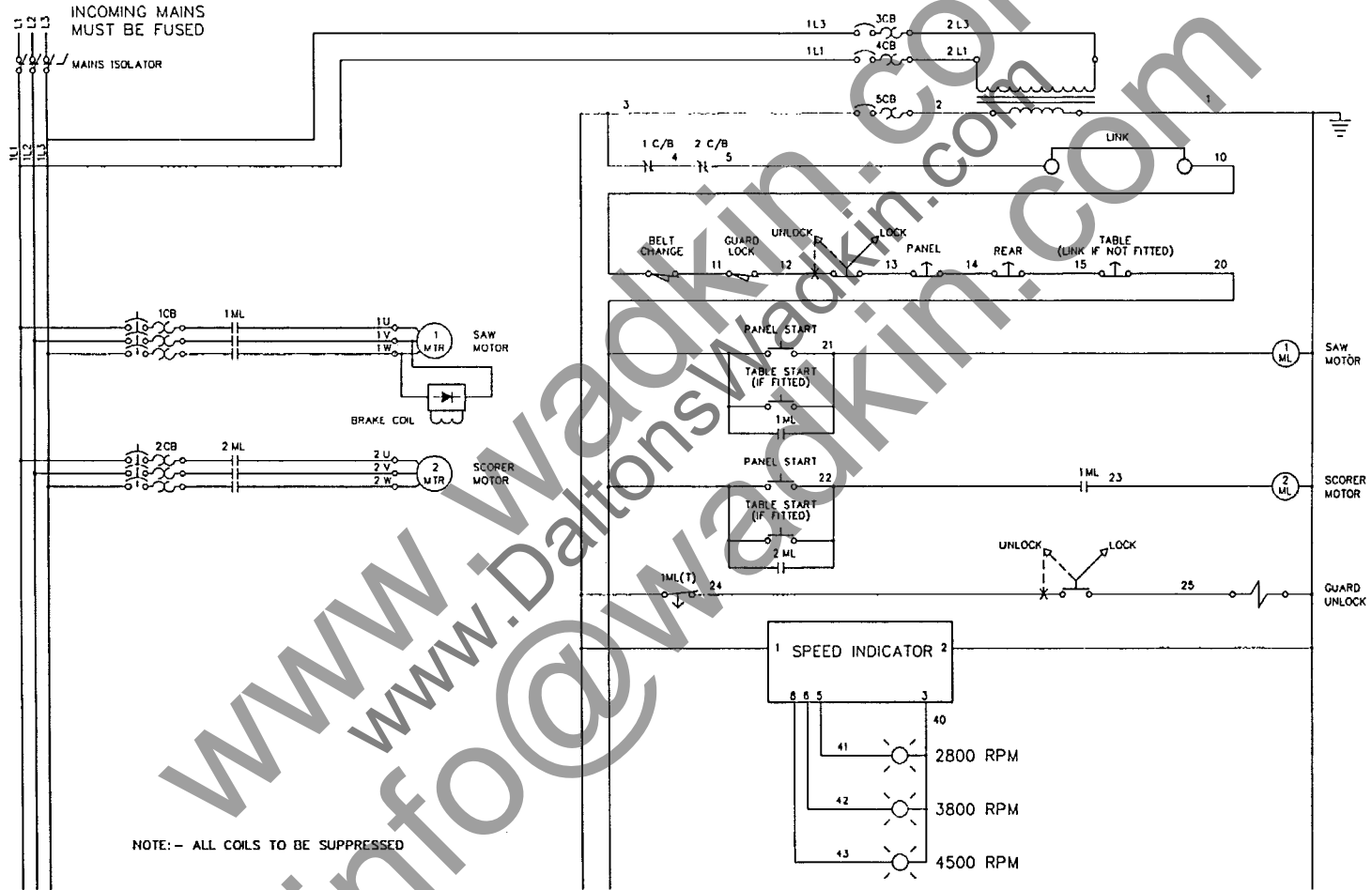

ELECTRICAL DIAGRAM SHOWING OPTIONAL SPEED INDICATOR AND UNDER SAW GUARD INTERLOCK

SECTION 2 UNLOADING , UNPACKING AND INSTALLATION

Unloading (Fig 1)

Verify the weight of the machine (see **Machine Specification**) and check that lifting equipment used is capable of lifting this weight as a minimum.

Three lifting eyes secured to the sides of the machine ensure slings are kept clear of the body.

WARNING:- Never walk or stand under a raised machine.

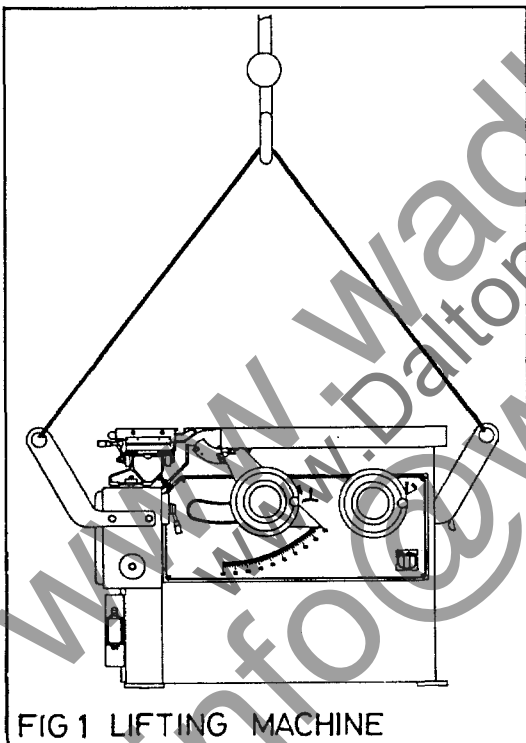

Unpacking

To reduce the size of the machine for transport several items have been removed and individually packed. These items as well as the main body should be unwrapped and checked to make sure no damage has occurred in transit and to ascertain that the machine is complete with all fittings.

Check delivered items against the following list :-

NOTE:- Extras or customer special parts will not be listed and should be checked against order.

Outrigger table
Turnover stops - 2 off
Crosscut fence
Main saw
Scoring saw
Riving knives
Rip fence guide bar
Rip fence body
Rip fence
Locking plate for
crown guard bar arm
Crown guard
Crown guard extraction adaptor
Crown guard arm
Side extension table
Leg for side extension table
Outer panel support
Rear extension table (Optional)
Legs for above- 2 off

Tool kit comprising of:-
Push stick (C.E machines only)
Instruction manual
46mm A/F spanner
32mm A/F spanner
17/19mm A/F double ended
spanner
8mm long arm allen key
6mm allen key
5mm allen key
3mm allen key
Control panel key

If in doubt about part identification refer to machine illustration in **section 1 general information.**



Cleaning

Before levelling the machine carefully remove the anti-rust material, particularly from the bright areas.

Clean the machine with paraffin or diesel and a soft rag. Do not use a substitute as it may precipitate an explosion.

Installation

For machine dimensions and specifications refer to **Section 1 General Information**.

Location and Foundation

To obtain the best results from the 'Wadkin' woodworking machine, it is important that the floor on which the machine is to stand has been prepared, is dry and level.

The panel saw should be so placed that the traffic of men and materials to and from the machine fits smoothly into the general production flow.

The operators normal working position should be away from the aisle, so as not to cause a hazard. The minimum clearance on each working side of the machine should be at least 1 metre greater than the maximum capacity.

The machine **MUST** be secured to the floor before use.

Rawbolts M12 size and large M12 washers may be used.

When machine is secured the M10 support screw must be lowered into contact with the floor.

Electrical Supplies

The customer is responsible for an adequate electrical supply. Details of power requirements are provided with the machine.

The machine is delivered with its complete electrical equipment ready for connection.

The electrical connection and schematic diagram are found in the electrical control cabinet as well as within the manual. The only connection to make is the power supply to the disconnect (isolator) switch.

POINTS TO NOTE WHEN CONNECTING THE POWER SUPPLY.

- a. Check the voltage, phase and frequency correspond with those on the machine name plate.
- b. Check the main fuses are of the correct capacity in accordance with the machine nameplate details.
- c. Connect the incoming supply leads to the appropriate terminals.
- d. Check the saw rotation is correct. The main saw should rotate towards operator and the scoring saw the opposite way.



To reverse the rotation of drive, reverse any two of the line lead connections at the incoming supply after having first isolated the machine at the mains.

WARNING:- Electrical work must be carried out by a qualified electrician.

Exhaust (Dust Extraction) Connections.

The machine has two dust extraction points, one at the rear for the base and the other at the crown guard.

Both outlets should be connected via a length of flexible pipe (suitable to cater for the adjustments) to the main duct.

The flow of air to the exhaust outlets should be approximately 20 metres per second for timber with a moisture content of below 18% or 28 metres per second if above.

The total volume of extracted air is 927 cubic metres per hour at 20 m/s or 1298 cubic metres per hour at 28 m/s.

The measured static pressure in the main extraction duct is 380Pa at 20 M/sec and 660Pa at 28 M/sec.

Re-assembly of machine.

Once the machine body has been properly sited and secured, remove the three lifting eyes and re-assemble in the following order:-

- 1) Mount main saw onto spindle (see **section 3**).
- 2) Fix and adjust riving knife.
- 3) Mount scoring saw onto spindle (see **section 3**).
- 4) Assemble crown guard and arm as follows:-
 - a. Slide crown guard arm (1) into support bracket (2) until stop is reached.
 - b. Insert jacking plate (3) between top of arm and bracket. Tighten grubscrews (4) until arm is securely held.
 - c. Fit crown guard (5) to arm (see **section 3**).

- d. If saw is not central within the guard, then slacken of grub screws (4) and reposition to suit. Tighten grub screws.

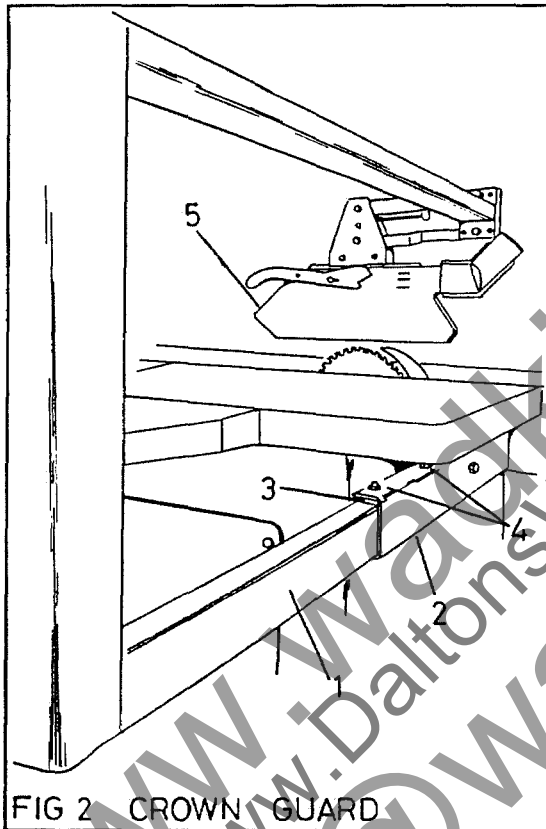

FIG 2 CROWN GUARD

- 5) Re-fit outrigger table by first positioning the outrigger table saddle (6) over round bar on sliding table. Lower outrigger table leg (7) onto swinging arm pivot (8).

NOTE: Whilst this can be done by a single person, the operation is simplified with two.

Tighten cam lock (9).

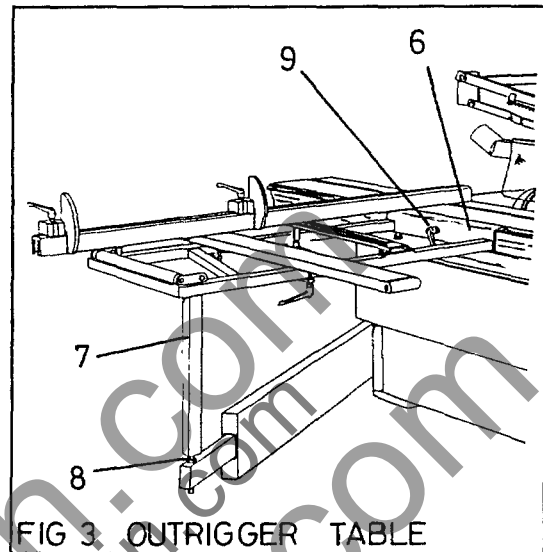

FIG 3 OUTRIGGER TABLE

- 6) Before fitting the outer panel support (10) unscrew and remove the locking handle (11) and washer from each clamp.

Slacken off lock nuts (12) enough to allow lower bars (13) to be removed from handle studs.

Place outer panel support onto outrigger table between scale and roller with each clamp straddling the frame of the table (14). Refit lower bars, washers and locking handles.

Tighten lock nuts (12) and locking handles until lower bar (13) is parallel to support and locking it in position.

NOTE:- The plastic pad fits between frame and support

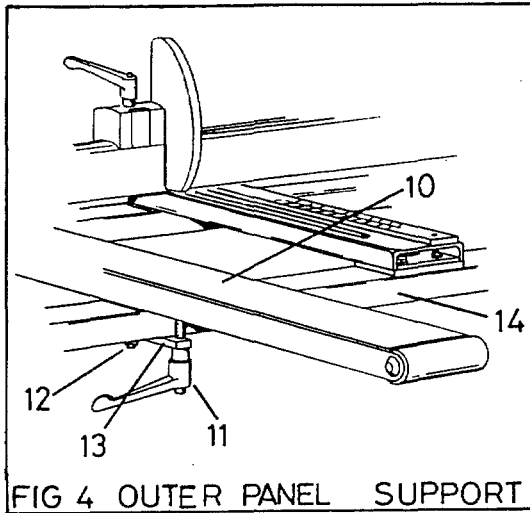

FIG 4 OUTER PANEL SUPPORT

- 7) To re-assemble the crosscut fence first place the white plastic washer(15) over the fence pivot pin before locating pin into the outrigger table saddle (16). Screw securing pin (17) in place. Fit and tighten crosscut fence locking handle (18) ensuring plastic washers (19) sandwich the slotted cross support.

NOTE;- The stepped washer fits on top of the slotted plate with the step locating in the slot.

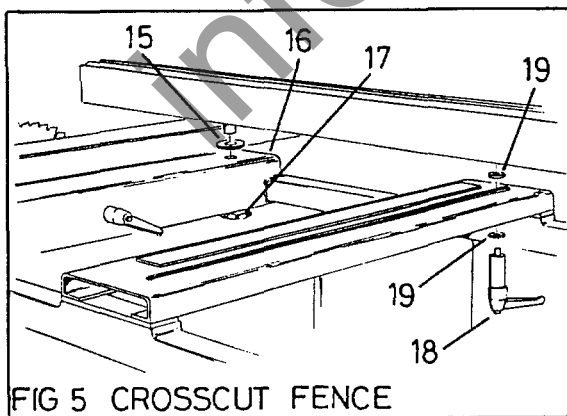

FIG 5 CROSSCUT FENCE

- 8) Slide turnover stop onto crosscut fence engaging tee nut (20) in top fence groove. Position to suit and turn handle (21) to lock.

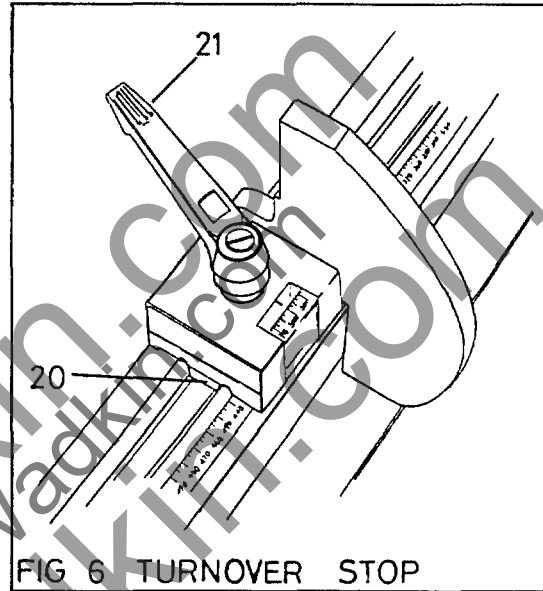

FIG 6 TURNOVER STOP

- 9) The side extension table (22) is secured to the main table (23) by two M12 set screws (24), which should initially only be fastened finger tight.

To level extension table to the main table, place a straight edge across both and adjust the two grubscrews (25).

Secure the extension table leg to the table using M8 screws and washers. Slots in the table cater for adjustment and the leg should sit firmly on the ground where it must be secured by an M12 rawbolt.

Lightly tighten table bolts (24).

11) Fit the rear extension table (if supplied) and lightly tighten the fixing screws. Level the table using a straight edge. When correctly set, securely tighten the table and leg support screws.

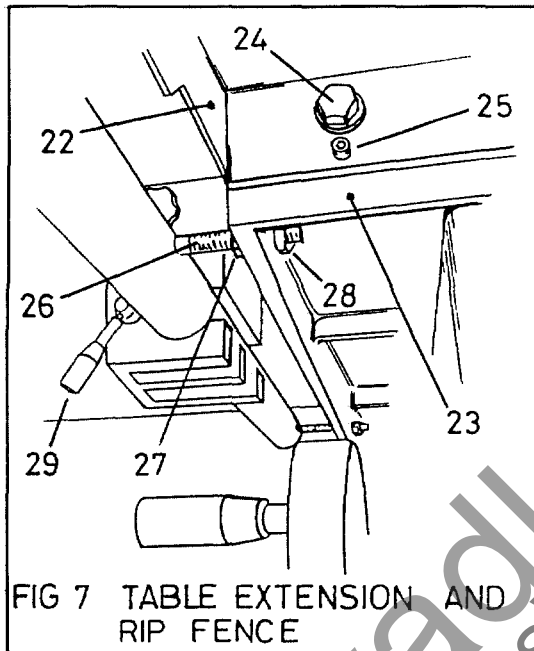

10) The first part of the rip fence assembly is the fitting of the rip fence guide bar.

NOTE:- This bar is generally only removed on export machines.

Push the guide bar support studs (26) through the mounting holes in tables and secure with M16 locknuts (28).

IMPORTANT:

The two rear locknuts (27) on each stud **must not** be moved as they are factory set to ensure the guide bar is square to the saw.

Slide rip fence body on to bar and tighten lock handle (29). Fit rip fence.

SECTION 3 OPERATING INSTRUCTIONS

GENERAL INFORMATION

Safety

The safe operation of woodworking machinery requires the constant alertness and close attention to the work in hand.

Read this instruction manual in its entirety before operating the machine.

Blunt saws often contribute to accidents. An efficient machinist knows when sharpening is necessary, but if there is a reluctance to spend time on sharpening then instead of cutting efficiently and smoothly they will tend to chop and snatch at the workpiece. This not only increases the risk of accidents but also lowers the quality of work.

When choosing a saw blade ensure it is suitable for the machine, material and saw speed.

Never raise the saw crown guard until the blade has come to rest.

Safety Devices (Fig 1)

All guards must remain in position whilst the saw is rotating.

The emergency stops located on the machine can also act as safety stops and must be engaged before working near components that can rotate i.e., saw blades, belts.

The removable cover (1) on the under table/saw guard may be interlocked via an electrical key (2) to the saw motor. This prevents removal of the cover until the saw is stationary.

An interlock fitted to the drive belt adjustment cover cuts the power to the motor preventing accidentally start up when working through the opening.

A push stick where provided with the machine must always be used to push the trailing end of the timber past the saw. When not in use it should be relocated on its support pegs.

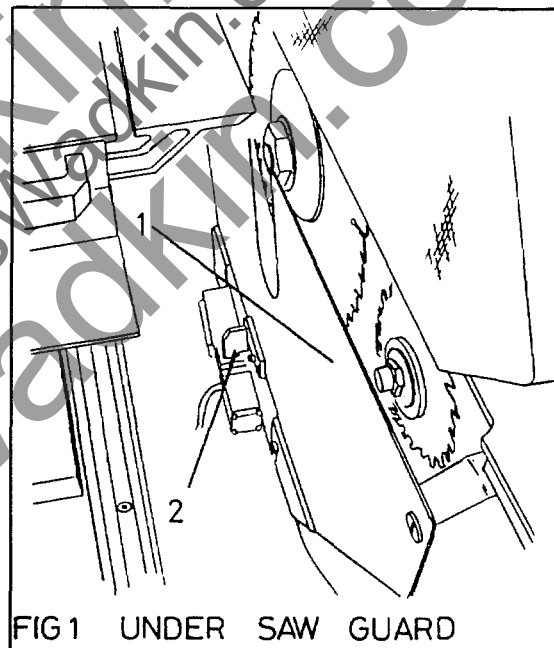

Controls (Fig 2)

Before starting the machine operators must familiarise themselves with the various controls, their usage and position.

The side of the machine with the two handwheels is referred to as the machine front and therefore the control panel is found on the left hand side of the machine.



The control panel may contain the following features.

- 1) SCORING SAW button to start saw.
- 2) MAIN SAW button. Push to start saw.
- 3) UNDER SAW GUARD switch (optional). Locked to the right, unlocked to the left. The guard cannot be unlocked if the power is off. With the switch in the unlock position the saws must be at rest before the covers can be removed
- 4) MASTER STOP. Push in to isolate power/stop machine, pull out to restore power. After returning power to the machine the saws will not start until their respective buttons are pressed again.

A second master stop is found on the front face of the machine.

- 5) SPEED INDICATOR. (optional)
Light illuminates to indicate selected speed.

Speed change is achieved by manually repositioning the main saw belt into a different groove on the pulley and is covered in the '**Machine Adjustments**' section.

The machine isolator is located on a return of the front face of the machine and is in the 'on' position when the central bar of the switch is vertical. In the 'off' position it is possible, using a padlock, to immobilise the switch and prevent unauthorised use.

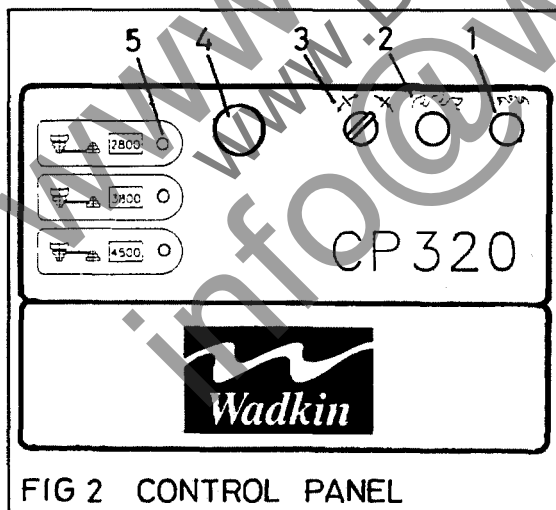

FIG 2 CONTROL PANEL

MOUNTING THE SAWS

Main Saw Replacement/Fitting (Fig 3, Fig 4)

- 1) Isolate power at emergency stop and allow saws to come to rest.
- 2) Raise saw to it's maximum setting.
- 3) Locate sliding table at it's maximum infeed position i.e at its full extent towards the operator, to allow clear access to both the saw positions.
- 4) Raise the crown guard (4) clear of the saws.
- 5) Use a screwdriver to release the two quarter turn lock screws (3).
- 6) The interlock (2) (if fitted) which prevents the under saw guard cover (1) from being removed has a time lock delay of between 10 and 20 seconds. After this time the guard can be lifted clear.
- 7) Locate and hold in position an 8mm allen key (5) in the hexagonal recess in the end of the main saw arbor. This will prevent the saw arbor rotating whilst the arbor nut (6) is being unscrewed.

After removing the arbor nut, the saw flange (7) and saw (8), if fitted, may be removed.

Note: The arbor nut has a left hand thread and is released by turning clockwise.

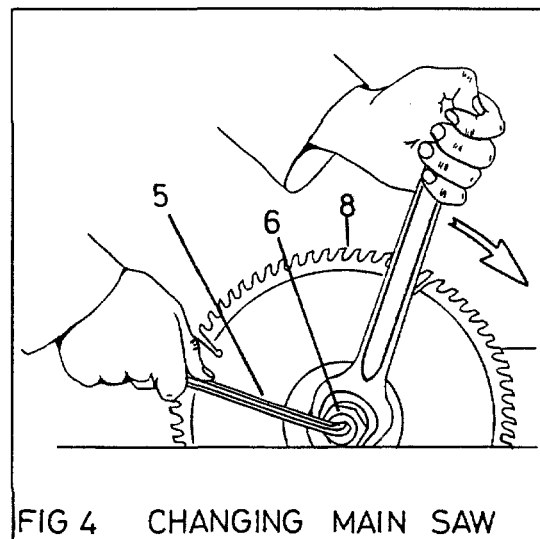
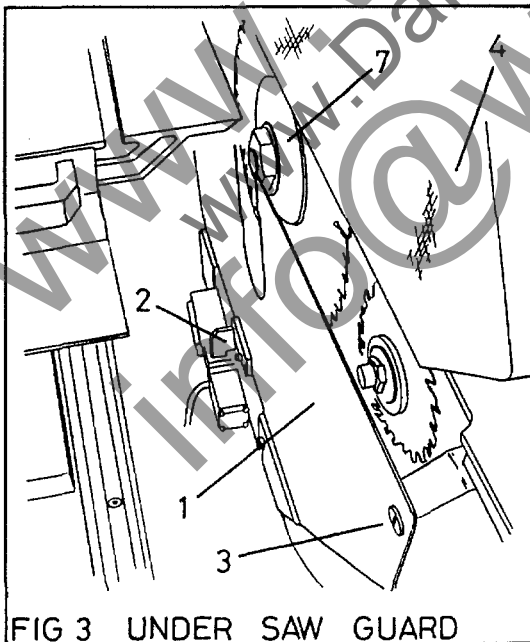



- 8) Before re-fitting and securing new saw blade check the following:-
 - i) The saw is suitable for the machine and workpiece.
 - ii) Blade, flanges and arbor are clean.
 - iii) The saw is in good condition.
 - iv) The teeth are facing the correct way i.e., towards the operator (infeed).
 - v) The riving knife is suitable for the blade.
 - 9) Replace saw flange (7) and tighten nut (6).
 - 10) Check positioning of riving knife to saw blade and adjust if necessary (refer to **Riving Knife Adjustment**).
 - 11) Replace and secure under saw guard (1).
 - 12) Position crown guard (4) to suit (refer to **Crown Guard Adjustment/Changing**).
 - 13) Reposition table and restore power by disengaging emergency stop.
 - 2) Locate and hold in position, an 8mm allen key in the hexagon recess in the end of the scoring saw spindle. Slacken off and remove the saw nut using a 32mm A/F spanner. The saw spindle has a right hand thread and thus the nut should be rotated anti-clockwise to release.
 - 3) Remove collar and saw (if fitted).
 - 4) The scoring saw splits in halves to allow shims to be inserted.
- The supplied shims are as follows:-
- | | |
|-------------|----------------|
| Green shim. | 003"(0.076mm) |
| Lilac shim. | 005"(0.127mm) |
| Black shim. | 010"(0.254mm) |
- The kerf (cutting width) of the scoring saw should be adjusted using these shims so as to equal or be slightly greater than the kerf of the main blade.
- Both saws should have the kerf etched onto their blades.
- Note:** Ensure mating faces of scoring saw and shims are clean and free from dirt before assembling. Check location pegs between saw halves are properly engaged.

Scoring Saw Replacement or Fitting

- 1) Follow steps 1-6 under main saw replacement/fitting.

- 5) Place scoring saw onto the clean spindle with the teeth facing towards the main saw.
- 6) Replace collar and tighten nut.
- 7) Replace and secure under saw guard.
- 8) Position saw guard to suit (refer to **Crown Guard Adjustment/Changing**).
- 9) Reposition table and restore power by disengaging emergency stop.

www.wadkin.com
www.DaltonsWadkin.com
info@wadkin.com

MACHINE ADJUSTMENTS

Crown Guard Adjustment and Changing (Fig 5)

Two guards are supplied with the machine, one for use when straight cutting the other for when the blade is canted.

Adjustment/Setting

The crown guard has a spring parallelogram action which allows the guard to remain in any placed position without the need of locks or clamps. The guard should be set no higher than 10mm above the workpiece.

Changing Guards

- 1) Isolate power at master stop.
- 2) Allow blades to come to rest before sliding off extraction ducting (1) from rear of guard.
- 3) Slacken off lock handle (2).

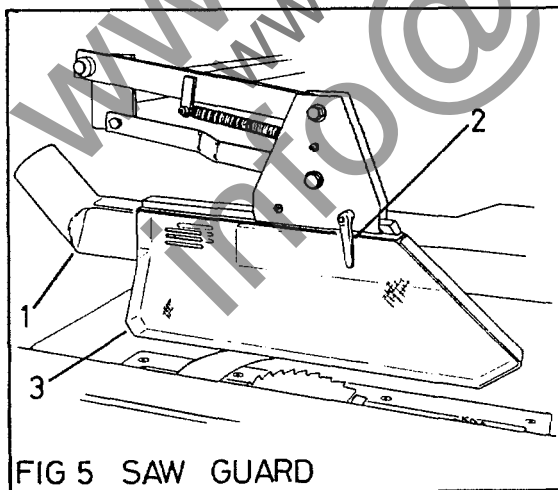

- 4) Raise guard clear of saw and slide guard (3) forward.
- 5) Fit alternative crown guard, checking it is located up to the stop.
- 6) Tighten lock handle, replace extraction ducting and re-engage power.

Main Saw Adjustment (Fig 6)

Height Adjustment

- 1) Slacken off locking knob (1).
- 2) Turn handwheel (2) clockwise to raise blade or anti-clockwise to lower.

Warning: Before attempting to set the blade to a specific height, against a rule for example, ensure emergency stop is pressed to isolate power and the saws are stationary.

- 3) When set refasten locking handle (1).

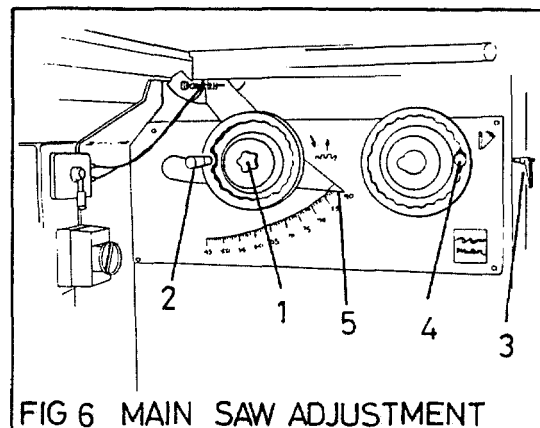

Cant Adjustment

- 1) Isolate power at emergency stop and wait for blades to cease rotating
- 2) Check correct guard is fitted.
- 3) Release locking handle (3).
- 4) Rotate handwheel (4) clockwise to cant saw blade to the right (towards the rip fence). A scale pointer (5) indicates the angle of the saw blade.
- 5) When set tighten locking handle (3).

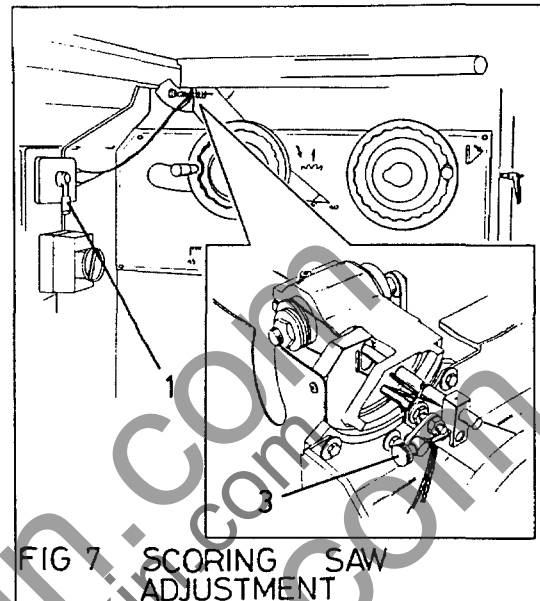

FIG 7 SCORING SAW ADJUSTMENT

- 6) Restore power.

Lateral Adjustment

- 1) Isolate power at emergency stop and check blades are stationary before proceeding

Scoring Saw Adjustment (Fig 7, Fig 8)

Height Adjustment

- 1) The scoring saw is at its lowest position when the handle (1) is down. To raise the saw pull the handle up clockwise.
- 2) The height of the saw above table level can be measured using a rule (4). The normal height setting is approximately 2mm.

- 2) Before laterally adjusting the scoring saw to align with the main saw ensure that the kerf of the scoring saw has been adjusted to suit main saw (see **Mounting Saws**).

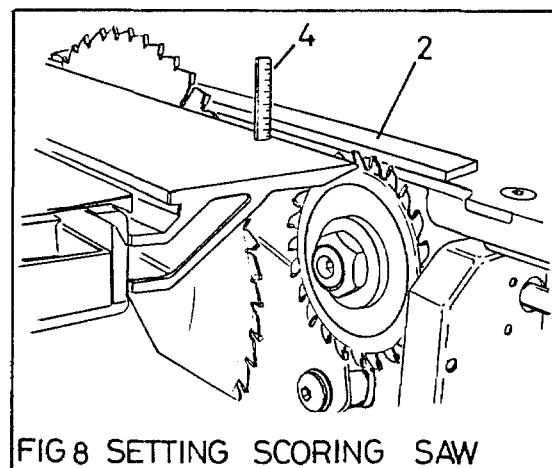

FIG 8 SETTING SCORING SAW

Warning: Isolate power at emergency stop and check blades are not rotating before checking height setting.

- 3) Place a straight edge (2) across the main saw and projecting over scoring saw.
- 4) Adjust the knurled knob (3) to laterally move the scoring saw. A clockwise rotation moves the saw towards the rip fence. When correctly set both sides of the main saw should align with the respective sides on the scoring saw.
- 5) Remove straight edge and restore power.

- 3) Slacken off the lock screw (3) and by sliding the clamp body (5) along the rail (4) and sliding the riving knife up or down, position riving knife so that at table level the gap between saw (2) and knife is a maximum of 8mm and the distance between the saw and the top edge of the knife is 3mm max.

Speed Adjustment (Fig 10)

The main saw has a three step 'V' pulley allowing for speeds of 2800, 3800 and 4500 rpm (the slower speed being the pulley groove closest to the saw).

Riving Knife Adjustment (Fig 9)

- 1) Isolate power at mains or at master stop and allow sawblades to come to rest.
- 2) Raise crown guard and check riving knife (1) is suitable for the saw diameter.

- 1) Isolate power at mains or at master stop.
- 2) Ensure sawblades are at rest.

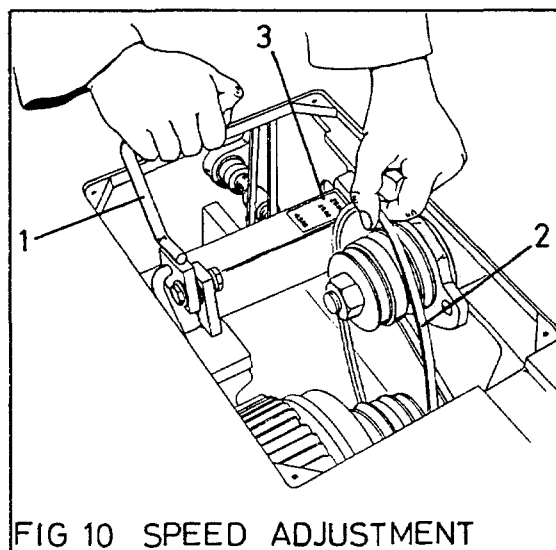
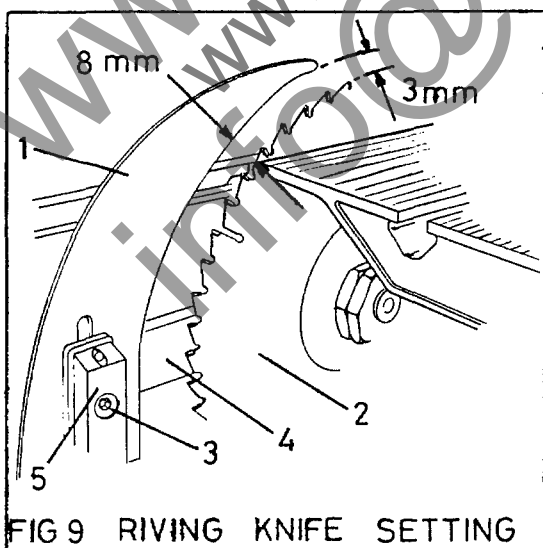

- 3) Remove access cover (located behind the saws) from the main table. Depending on machine build specification this cover may be interlocked to cut out the drive motor should the operator have failed to previously stop the machine.
- 4) Pull handle (1) up and over to release belt tension.
- 5) Reposition drive belt (2) to suit saw blade speed as indicated by information plate (3).
- 6) Retention belt by pushing handle forward and down.
- 7) Refasten cover and restore power.

Rip Fence (Fig 11, Fig 12)

The rip fence plate (1) may be fitted in two positions. In the main illustration the fence plate is upright for deep stock whilst in the other position it is for use with faced panels, melamine, veneer etc., and small components.

The rip fence may be used as an end stop when using the sliding table. To avoid small cut-offs from wedging between the sawblade and fence always set the fence plate forward of the saw by approximately 50mm.

Fence Plate Re-positioning

- 1) Slacken off locking handle (2).
- 2) Slide rip fence plate (1) into desired position

or

Slide rip fence from body, turn to alternative working face and slide 'T' slot over location button (3) and locking bar (4). Reposition fence longitudinally to suit.

- 4) Tighten locking handle (2).

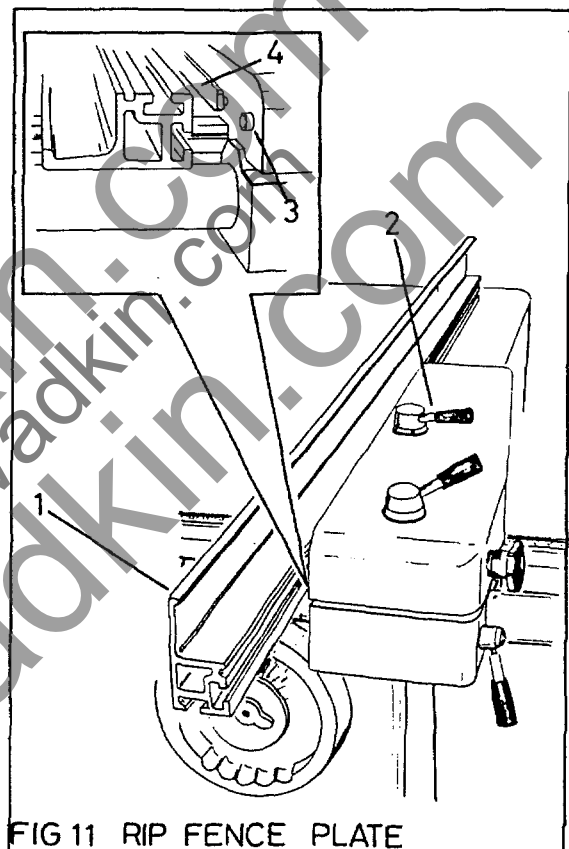

FIG 11 RIP FENCE PLATE

Rip Fence Adjustment

A. Rapid Adjustment

- 1) Slacken off locking handle (5) and (8).
- 2) Position unit to suit timber cut width.

Note: A rule (6) inset into the machine body indicates the distance from the edge of the sawblade to the face of the fence plate (7).

3) Relock handle (5) and (8).

2) Turn adjustment knob (9) clockwise to reduce distance between saw and fence plate or anti-clockwise to increase.

3) Tighten locking handle (5).

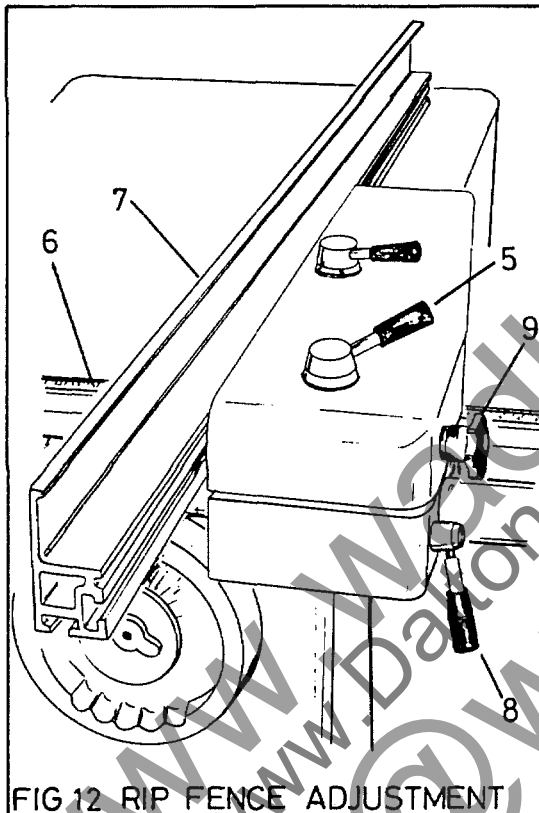

Crosscut Fence, Outrigger Table and Turnover Stop (Fig 13)

The crosscut fence can pivot from either the rear (as illustrated) or front of the outrigger table to allow for mitre cuts.

Setting for Mitre Cut

1) Slacken off locking handle (1).

2) Pivot crosscut fence (2) until the infeed side of the fence aligns with the desired angle reading on the scale (3).

3) Tighten handle (1).

If the fence should need to be pivoted from the opposite point then both the locking handles (1) and (4) must be fully unscrewed and removed.

Re-position fence ensuring all spacers, washers etc., are correctly fitted and then refit handles.

Outrigger Table

The outrigger table (12) may be moved along the length of the sliding table to facilitate mitre cuts by releasing locking handle (5).

B. Micro Adjustment

If after machining a test piece, the rip fence needs to be slightly altered then the micro adjustment allows for this.

1) Slacken off locking handle (5).

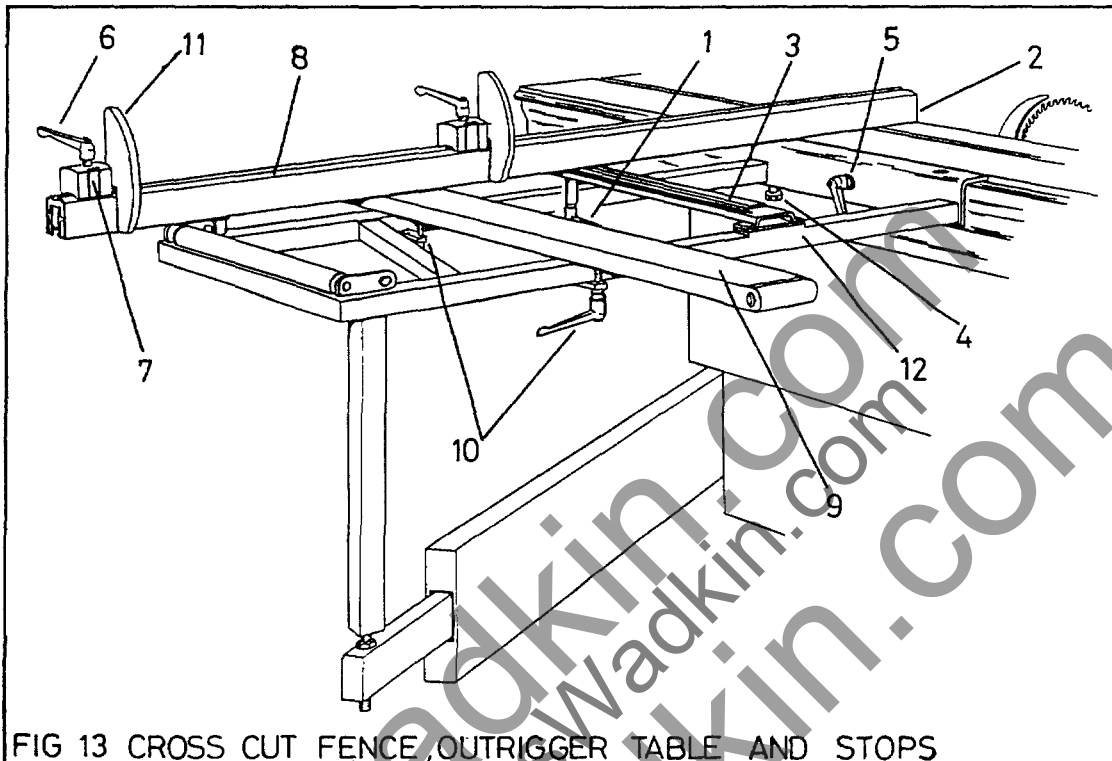

FIG 13 CROSS CUT FENCE, OUTRIGGER TABLE AND STOPS

The outer panel support (9) may be adjusted by slacking off the two locking handles (10), positioning to suit panel and then re-tightening handles.

Turnover Stops

Two turnover stops are fitted to the crosscut fence to enable timber to be positioned in the correct relationship to the sawblade and for repeat cuts on the same timber size.

- 1) To position stop slacken off locking handle (6).

2) Looking through the perspex prism pointer (7) onto the scale rule (8) fixed to the crosscut fence, position stops at the desired setting.

- 3) Tighten handle (6).

Note: The stop plate (11) may be pivoted to the opposite side depending on the angle of the fence.



Sliding Table (Fig 14)

The sliding table may be locked in certain positions to allow safe and easy handling of work.

Before locating large panels the table should be brought to the maximum forward position and locked by pushing handle (1) downwards.

Note: To allow the sliding table maximum forward movement the outrigger table should be set at the rear of the sliding table.

When the panel, stops, etc., are positioned the lock handle (1) may be released.

For ripping operations the table is normally locked in the mid position i.e., when sliding table and fixed runner base are directly above each other (as shown in illustration).

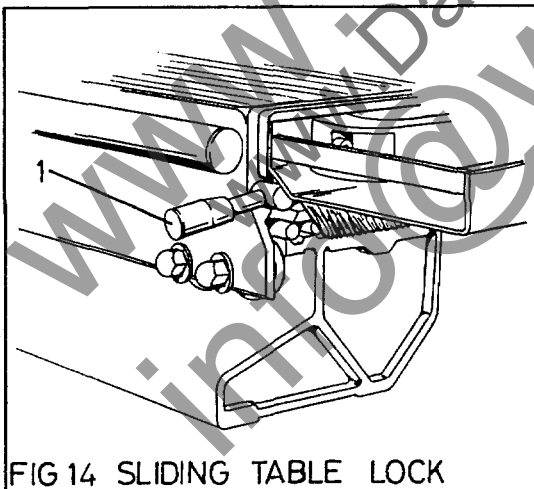

FIG 14 SLIDING TABLE LOCK

NOTE:

It May be found that the sliding table will not move through its max. travel. This can occur after a prolonged period of short cutting strokes.

With the machine switched off move the sliding table to the rear of the machine to the limit of its travel, then gently "bump" the table until the dead stop has been reached.

SECTION 4 MAINTENANCE

The machine has been designed to keep the ease and scale of maintenance to a minimum. Regular scheduled maintenance such as lubrication and cleaning should be carried out to ensure the machine is in a good operating condition and capable of safely producing good quality trouble free work with the minimum of downtime

Lubrication (Fig 1, Fig 2)

Isolate machine at mains or at master stop and allow saw blades to come to rest before proceeding with the lubrication procedure.

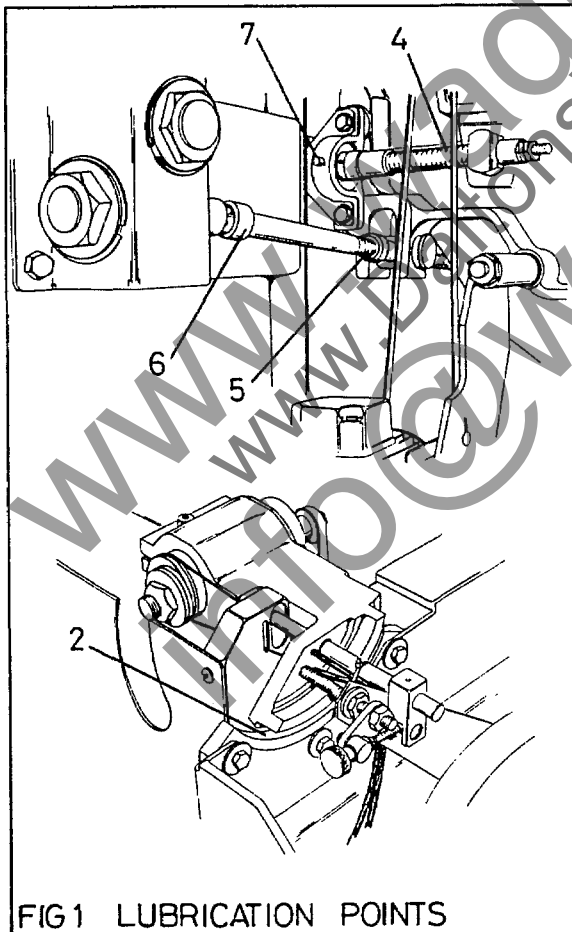

weekly

Lightly lubricate using Wadkin L4 oil, the following areas:-

- 1) Sliding table guide bars (1)
- 2) Saw cant slides (2)

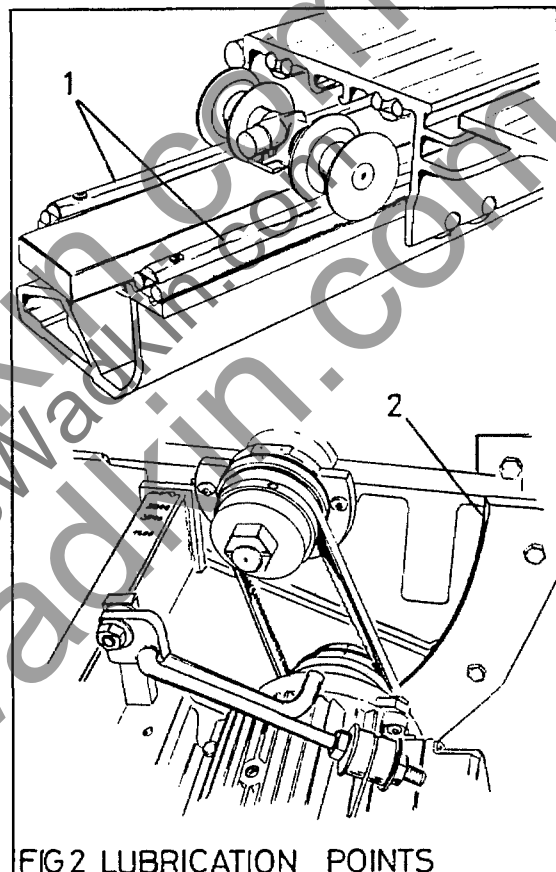

Wadkin grade L6 grease should be used on:-

- 1) Main saw rise and fall slides (3)
- 2) Screw threads of rise and fall shaft (4)
- 3) Screw threads of canting shaft (5)

To assist in the prevention of resin/sawdust build up the machine should be traversed to all its limits.

Monthly

Use Wadkin grade L6 grease to lubricate universal joint (6) on cant shaft. The plummer bearing block (7) on the saw rise and fall shaft should be lubricated with Wadkin L6 grease whilst the shaft is slowly rotated.

Where brake motors are fitted check stopping times (see **Brake Motor Maintenance**).

Three monthly

Prior to scheduled lubrication clean all screw thread adjustments and slides with a resin solvent.

After lubrication traverse screw threads and slides to their limits to ensure even and total coverage of lubricant

Checking/Adjustment of Main Saw Drive Belt Tension (Fig 3)

Before attempting to check/adjust the belt tension isolate power at mains or at master stop, and ensure blades are at rest.

The belt is at the correct tension when the application of an average thumb pressure of 22-31N (5-7 lbf) at the belts mid span deflects the belt by 8-10mm.

Adjustment

- 1) Release the tension on the drive belt (1) by raising the handle (2) to the upright position.
- 2) Slacken off locknut (3) one full turn and then tighten locknut (4) by the same amount.

Note: Adjustment in this manner increases the tension and should be reversed if the tension is to great.

- 3) Re-apply the tension by pushing, the handle (2) down towards the motor until it latches into position. Check belt is in the correct pulley groove to give the speed suitable for the saw blade.
- 4) Recheck belt tension.
- 5) Repeat procedure until correct tension is obtained.

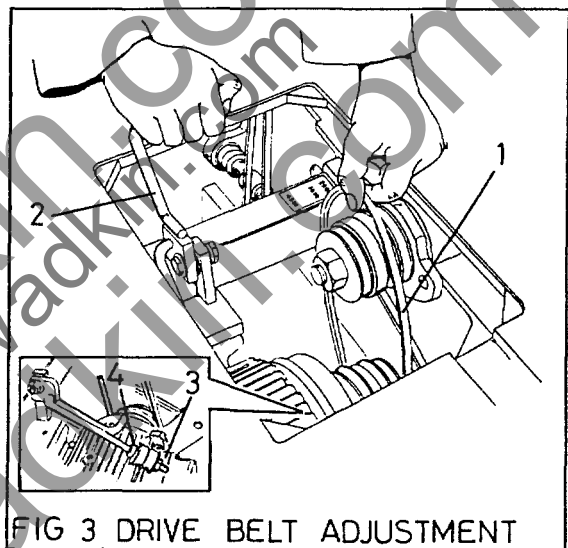

FIG 3 DRIVE BELT ADJUSTMENT

Scoring Saw Drive Belt Tensioning

The tensioning of the belt is provided purely by the weight of the pivoted motor acting on it and therefore becomes self adjusting.

Brake Motor Maintenance (Fig 4)

The friction disc brake in the motor is not adjustable and when it has worn down to such an extent that the brake operating air gap has opened up to 0.65mm (brake de-energised) the disc should be replaced.

To measure this gap would entail the strip down of the motor and therefore it is more practicable to measure the stopping time. A period significantly greater than the normal 10-12 seconds should be investigated.

Before proceeding isolate power at machine isolator.

Remove any covers or guarding to allow unimpeded access to the motor. Unscrew motor cowl fasteners and pull cowl clear. Remove fan from motor shaft. Plastic fans are normally secured by pins and metal fans by key and/or grub screws. With the fan removed the brake unit should be visible.

To replace the friction disc, the brake must firstly be removed from its mounting by removal of the four fixing screws (1) and withdrawing the brake from the hub. When this has been accomplished, lightly bend back the system locking tabs (4) by about 1mm, (using snipe nosed pliers) this enables the assembly to be separated by contra-rotating the flange (2) and the magnet system (3). The worn disc (5) can then be removed. It will be noted that the friction disc (5) has a protruding boss at one side of the toothed bore, ensure when installing the new disc, that this boss is situated at the mounting flange (2) side of the brake.

To re-assemble, reverse the dismantling procedure then ensure the locking tabs (4) are fully re-clamped. Visually centralise the disced toothed bore by thumb pressure, then re-mesh onto the brake hub, re-fasten into position by fixing screws (1). Replace fan, cowl and any removed guards or covers, ensuring they are securely fastened where necessary.

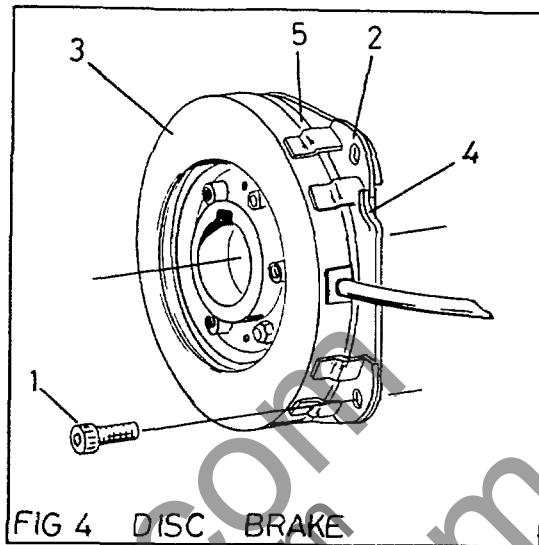

Cleaning

It is recommended that the machine be cleaned thoroughly once a week.

If cleaning with compressed air, take care not to direct the jet at bearing housings, slide joints, moving shafts, etc.

Clean the saw spindles, collars, tables, fences and riving knives to remove all remains of resin and saw dust.

Particular attention should be taken to clean the hexagonal hole in the ends of both the saw spindles as residual build up in here prevents positive location of the allen key when changing saw blades.



FAULTING FINDING

Fault *The machine does not start.*

Possible Causes

- a) Master stop button is depressed.
- b) Inline fuse blown.
- c) No incoming supply to machine.
- d) Interlocked covers (if fitted) not replaced or incorrectly fitted.

Remedial Action

- Release master button and re-start machine.
- Isolate machine from mains supply and replace blown fuse.
- Check supply to all three phases.
- Re-place or re-fit covers

Fault *The machine stops during working.*

Possible Causes

- a) Thermal overloads tripped out
- b) Interruption to incoming supply.
- c) Inline fuses blown.

Remedial Action

- Allow overloads to cool down and then check setting matches the required motor setting as indicted on the motor plate. If setting is correct investigate reason for tripping e.g faulty motor, over size timber being fed in, etc
- Check supply to all three phases.
- Isolate machine from mains supply and replace blown fuses.

Fault *The machine vibrates.*

Possible Causes

- a) Improperly tensioned saw blade
- b) Broken teeth in saw blade
- c) Flats worn on main saw drive belt
- d) Wood chips embedded in belt

Remedial Action

- Replace blade.
- Replace blade.
- Replace belt.
- Replace belt.

WARNING

Only qualified and authorised personnel shall carry out repairs and maintenance.

APPROVED LUBRICANTS

WADKIN	CASTROL	B.P	SHELL	MOBIL	ESSO	GULF	CALTEX
L1	Hyspin AWS 32	energol HLP 32	Tellus 37	DTE oil Light 24	Nuto H32 43 AW	Harmony Oil HDA	Rando
L2	Alpha ZN 150	Energol HP 150	Vitrea 150 or CS 150	Vactra Extra	Spartan EP 150 Heavy	Service 13	URSA P40
L4	Magna 68	Energol HP 68	Vitrea 68 or CS68	Vactral Oil	Nurray 68 Heavy Medium	Service 51	URSA P20
L6	Spheerol AP3	Energrease LS3	Alvania Grease No 3	Mobilplex Grease No 48	Beacon 3	Gulfcrown Grease No 3	Regal Startak Premium 3

- L1 Oil Hydraulic oil with anti-corrosion, anti -oxidation, anti wear, anti-foam performance.
- L2 Oil Gear oil (viscosity 150 centi-stokes at 40 degrees c).
- L4 Oil Plain mineral oil (viscosity 68 centi-stokes at 40 degrees c).
- L6 Grease Grease NLG1 No3 consistency lithium bearing grease.

SECTION 5 SPARE PARTS

CONTENTS

1. MAIN SAW- SPINDLE ASSEMBLY
2. SCORING SAW- SPINDLE ASSEMBLY
3. SCORING SAW ADJUSTMENT AND SWING
4. MAIN SAW RISE AND FALL ASSEMBLY
5. CANTING MECHANISM ASSEMBLY
6. RIVING KNIFE ASSEMBLY
7. SLIDING TABLE ASSEMBLY
8. TURN-OVER STOPS
9. MANUAL CLAMP
10. HANDLES AND LOCK FOR SLIDING TABLE
11. MOTOR MOUNTINGS AND SWING

www.DaltonsWadkin.com
www.DaltonsWadkin.com
info@wadkin.com

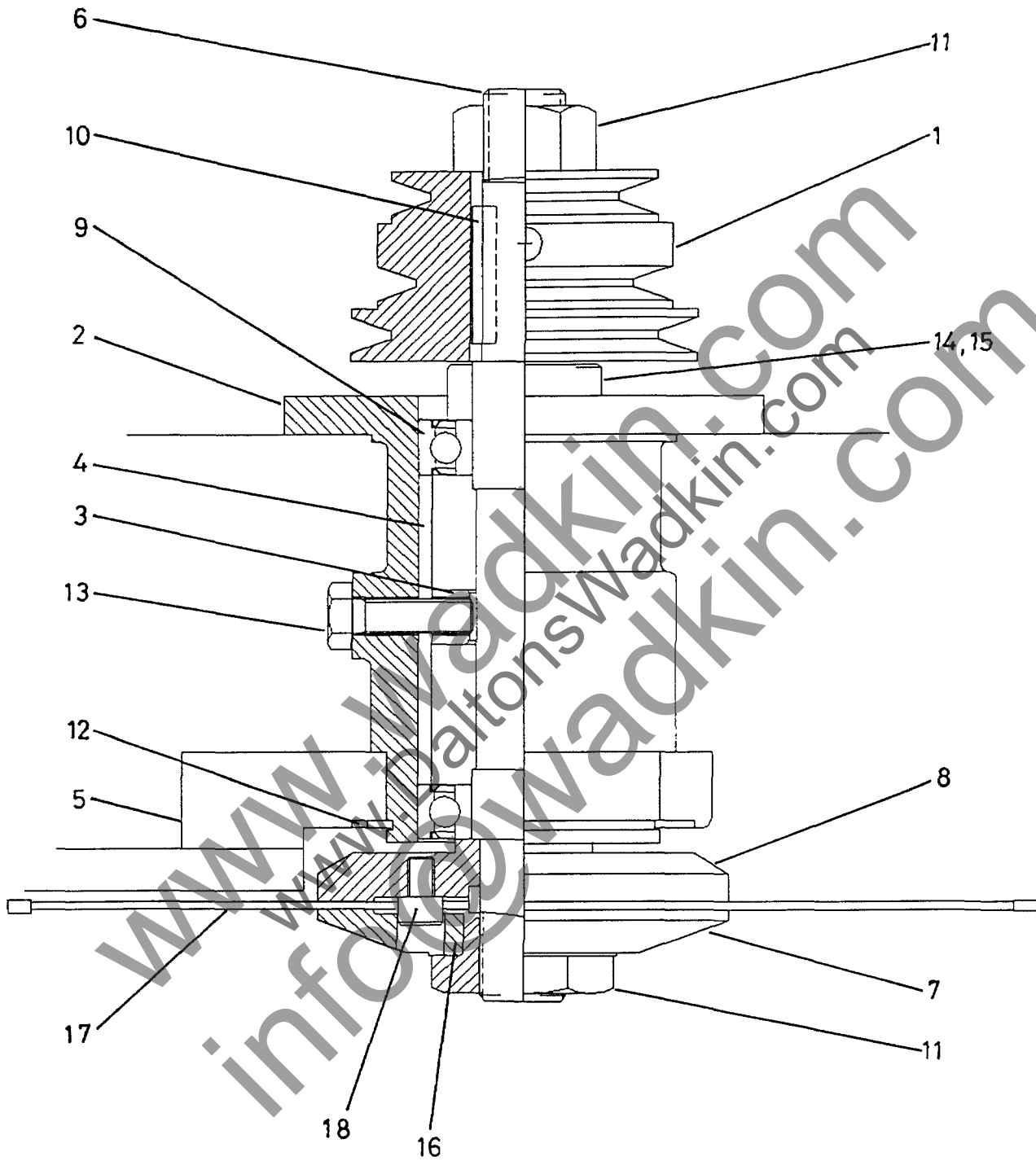

FIG 1 MAIN SAW - SPINDLE ASSEMBLY

1. MAIN SAW SPINDLE ASSEMBLY

Ref No	Description	No Off
1.	Spindle pulley	1
2.	Main spindle housing	1
3.	Trapping collar	1
4.	Bearing spacer	1
5.	Pivot bracket	1
6.	Spindle assembly comprising of:- spindle Rear saw flange Saw location screw Bush	
7.	Front saw flange	1
8.	Rear saw flange (See Ref No 6)	1
9.	'SKF' bearing ref 6206-2RS	2
10.	key 8mm x 7mm x 40mm long	1
11.	Self locking nut M24 x 1.5p	1
12.	External circlip 80mm dia	1
13.	Hexagon head setscrew M10 x 35mm long	1
14.	Locking collar	1
15.	Hexagon socket grubscrew M8 x 10mm long	2
16.	Bush (See Ref No 6)	
17.	Saw (30mm internal mounting diameter)	1
18.	Saw location screw (See Ref No 6)	

www.DaltonsWadkin.com
www.DaltonsWadkin.com
info@wadkin.com

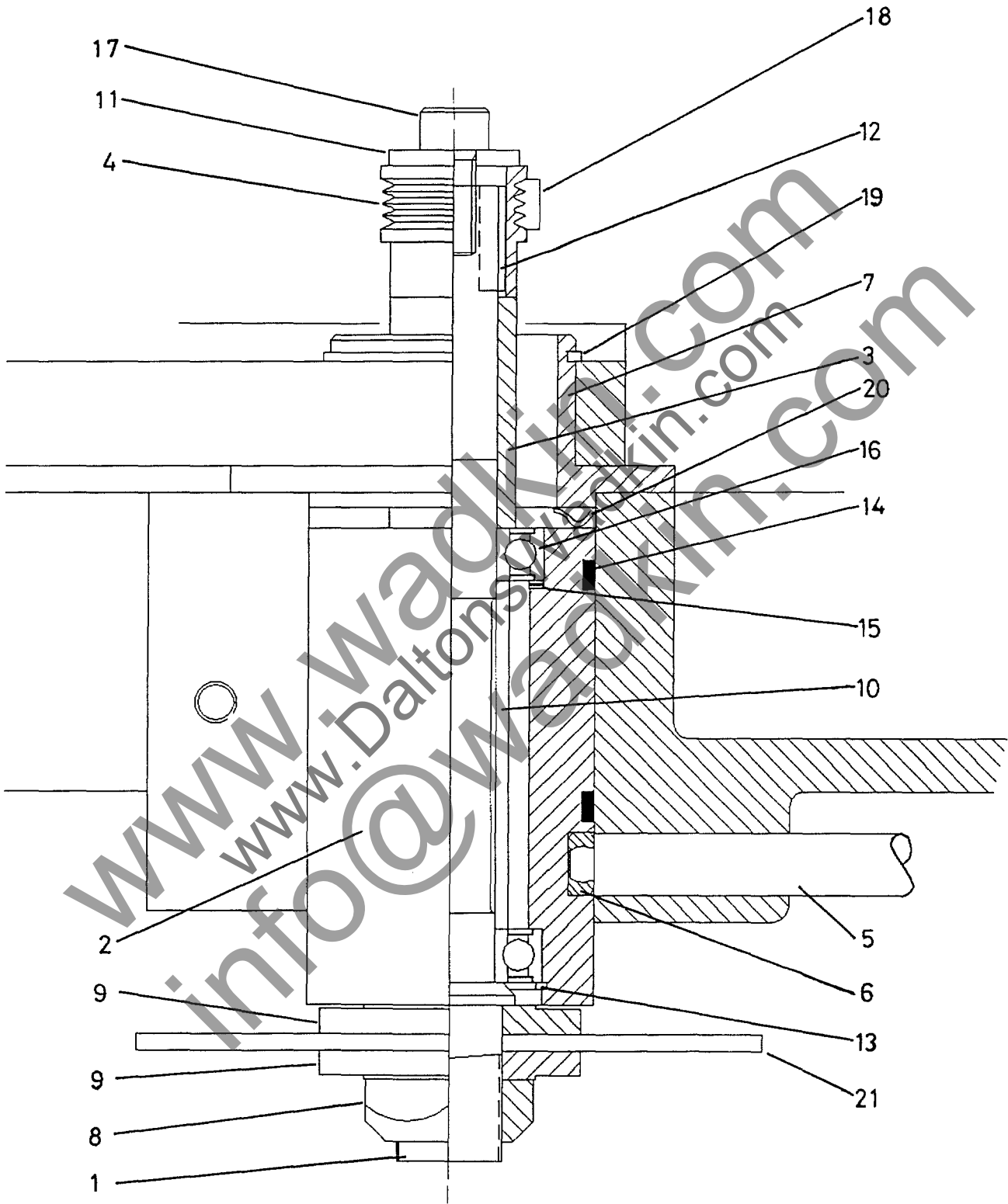

FIG 2 SCORING SAW – SPINDLE ASSEMBLY

2. SCORING SAW - SPINDLE ASSEMBLY

Ref No	Description	No Off
1.	Saw spindle	2
2.	Quill	1
3.	Pulley spacer	1
4.	Spindle pulley	1
5.	Quill adjustment shaft	1
6.	Shoe for quill	1
7.	Rise and fall pivot	1
8.	Spindle pivot	1
9.	Saw flange	2
10.	Bearing spacer	1
11.	Washer	1
12.	Key 5mm x 5mm x 20mm long	1
13.	Internal circlip 35mm dia	1
14.	Shamban ring	2
15.	Pre-loaded washer ref EPL28	1
16.	'SKF' bearing ref 6003-2RS	2
17.	Hexagon head socket screw M8 x 20mm long	1
18.	Drive belt ref 460J4	1
19.	External circlip 47mm dia	1
20.	Wavy washer ref EPL45	1
21.	Scoring saw	1

www.DaltonsWadkin.com
info@wadkin.com

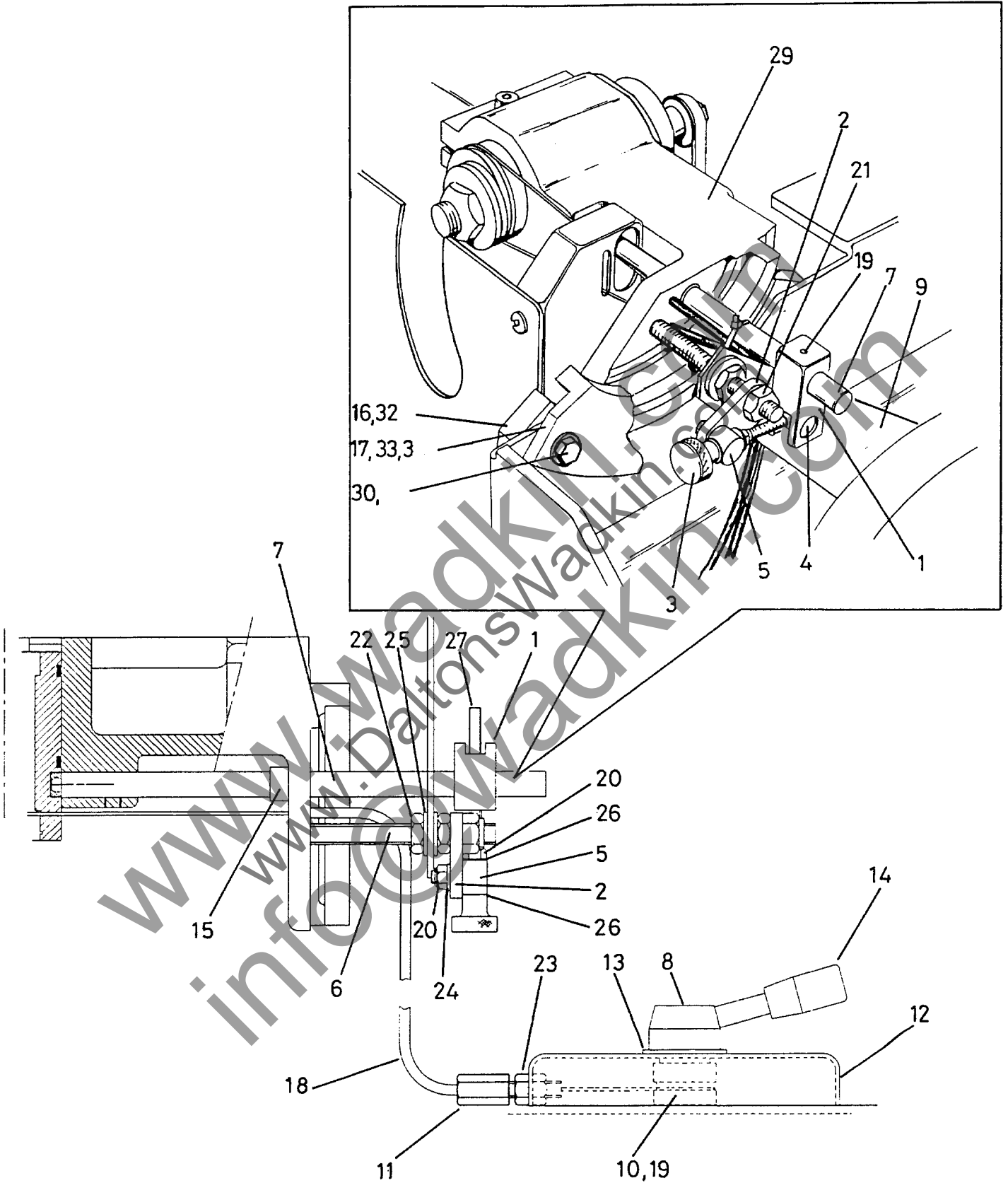

FIG 3 SCORING SAW ADJUSTMENT

3. SCORING SAW ADJUSTMENT AND SWING

Ref No	Description	No Off
1.	Scorer adjustment yoke	1
2.	Pivot plate	1
3.	Adjusting knob	1
4.	Yoke pivot	1
5.	Adjust pivot	1
6.	Adjustment stud	1
7.	Quill adjusting shaft	1
8.	Lock handle	1
9.	Pointer	1
10.	Adjustment spindle	1
11.	Cable adjuster	2
12.	Adjustment box	1
13.	Large washer	1
14.	Lever arm	1
15.	Bronze bush 16mm O/D x 12mm I/D x20mm long	1
16.	Trunnion slide (one fitted either Side of machine)	2
17.	Trunnion trapping plate (either side of machine)	2
18.	Reinforced sleeve and cable	1
19.	Hexagon socket grubscrew M6 x 8mm long	2
20.	Self locking nut M6	2
21.	Self locking nut M10	1
22.	Locknut M10	2
23.	Nut M8	2
24.	Plain washer M6	1
25.	Plain washer M10	2
26.	Fibre washer M6	2
27.	Threaded bar M6 x 100mm long	1
28.	Plain washer M8	6
29.	Trunnion	1
30.	Hexagon setscrew M8 x 30mm long	6
31. +	Brass adjusting screw M8 x 20mm long	2
32. +	Tension pin M6 x 16mm long	4
33. +	Locket nut M8	2

+ Not illustrated

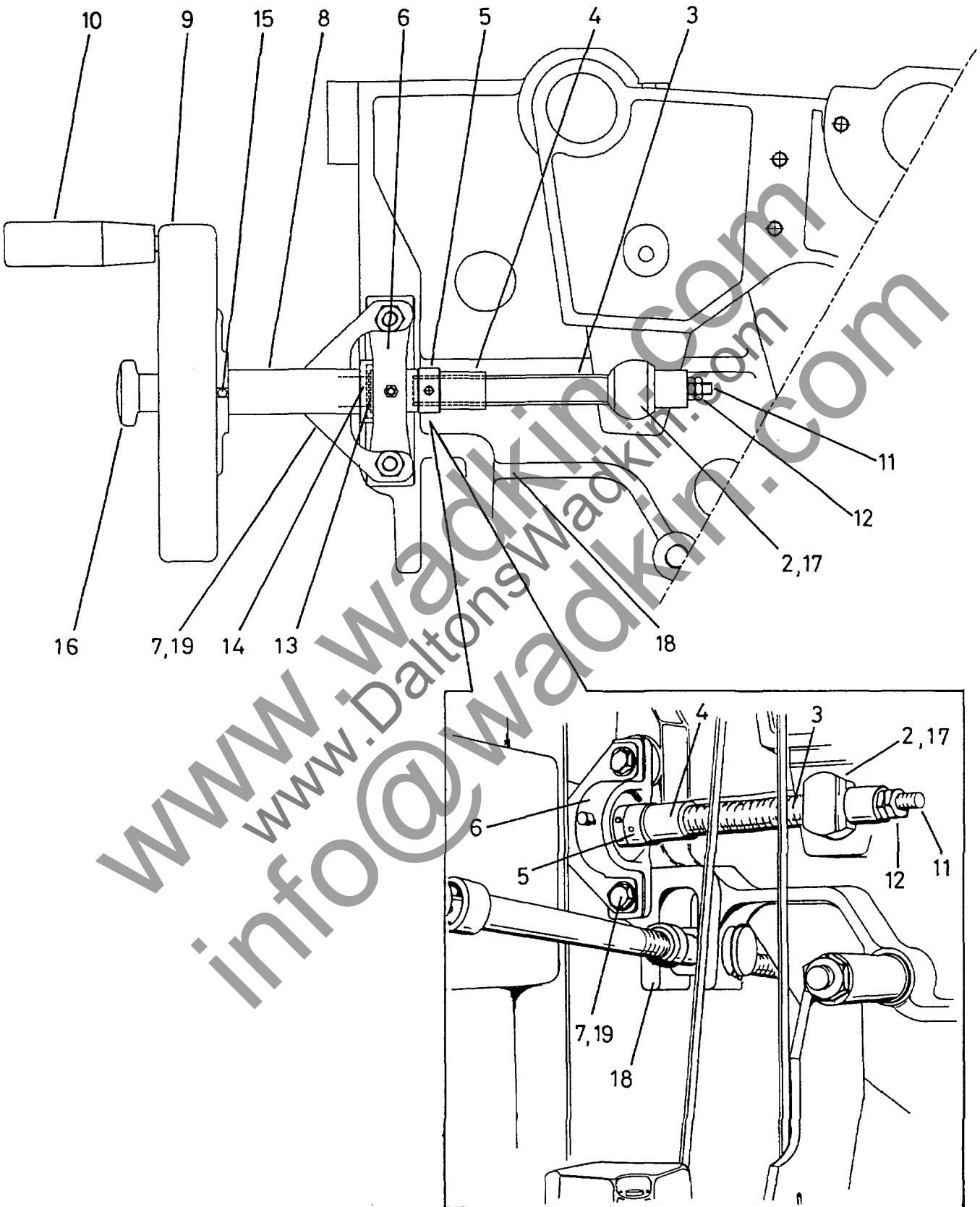

FIG 4 SAW RISE AND FALL ASSEMBLY

4. SAW RISE AND FALL ASSEMBLY

Ref. No	Description	No. Off
1.	Rise and fall stop	1
2.	Rise and fall nut	1
3.	Rise and fall shaft	1
4.	Stop collar	1
5.	Stop nut	1
6.	R.H.P. plummer block bearing ref SL20	1
7.	Pointer bracket	1
8.	Shaft sleeve	1
9.	Handwheel	1
10.	Handle	1
11.	Stud M8 x 40mm long	1
12.	Locknut M8	2
13.	External circlip dia 20mm	1
14.	Lock washer	1
15.	Tension pin dia 5mm x 30mm long	1
16.	Locking knob	1
17.	External circlip dia 25mm	1
18.	Rise and fall bracket	1
19.	Hexagon head setscrew M10 x 85mm long	2

www.Wadkin.com
www.DaltonsWadkin.com
info@wadkin.com

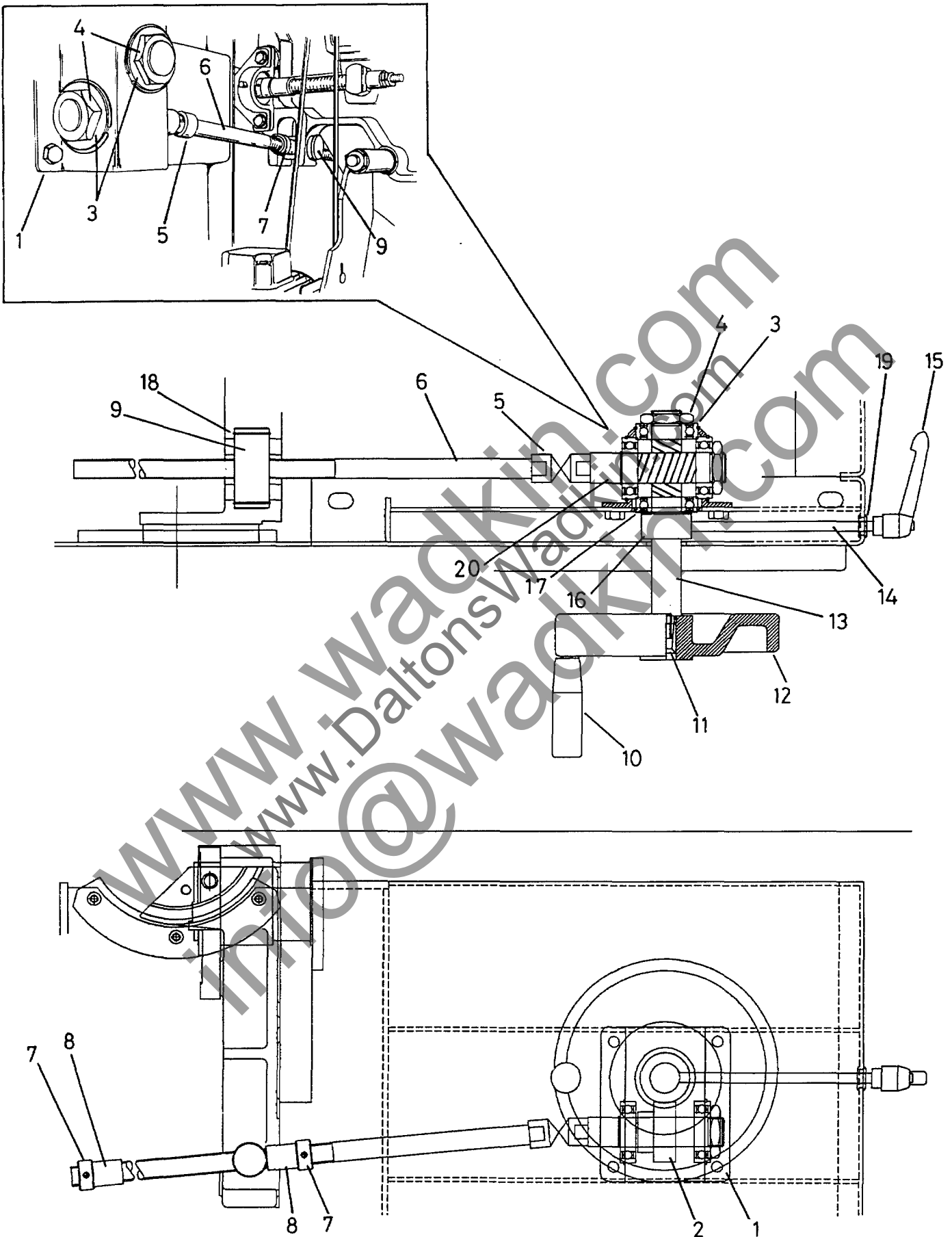

FIG 5 CANTING MECHANISM ASSEMBLY

5 CANTING MECHANISM ASSEMBLY

Ref. No	Description	No. Off
1.	Gearbox	1
2.	Canting gear	1
3.	S.K.F bearing ref 6206 2Z NR	4
4.	Nut M30	2
5.	Coupling	1
6.	Canting shaft	1
7.	Stop nut	2
8.	Stop collar	2
9.	Canting nut	1
10.	Handle	1
11.	Taper bush	1
12.	Handwheel	1
13.	Handwheel shaft	1
14.	Lock stud	1
15.	Locking lever	1
16.	Locking collar	1
17.	External circlip dia 30mm	1
18.	External circlip dia 35mm	2
19.	Rubber grommet dia 10mm	1
20.	Output shaft	1

WWW.WADKIN.COM
WWW.DALTONSWADKIN.COM
info@wadkin.com

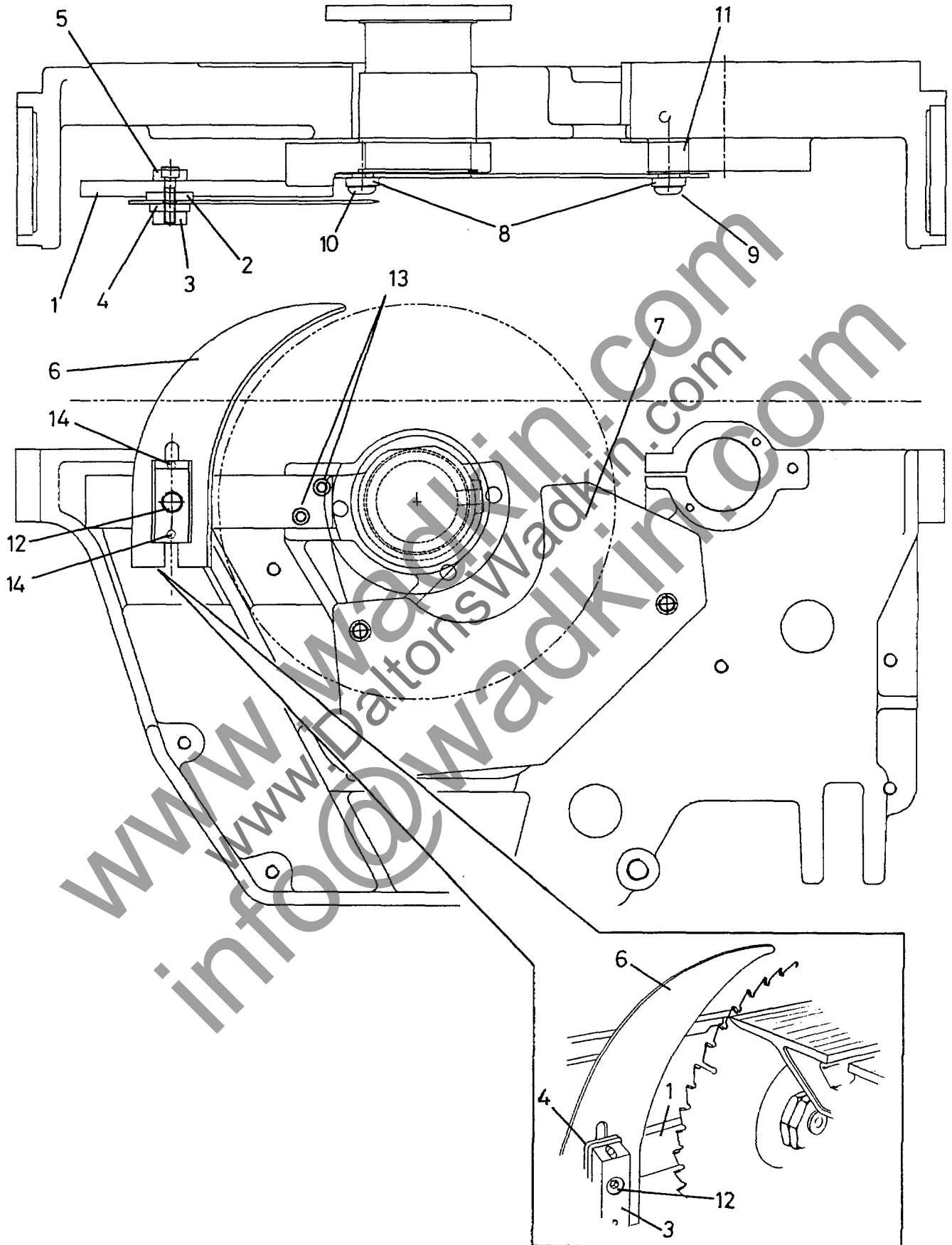

FIG 6 RIVING KNIFE ASSEMBLY

6. RIVING KNIFE ASSEMBLY

Ref. No	Description	No. Off
1.	Slide bar	1
2.	Guide plate	1
3.	Clamp plate	1
4.	Pressure plate	1
5.	Rear clamp plate	1
6.*	Riving knife	1
7.	Link plate	1
8.	Pivot washer	1
9.	Hexagon socket button head screw M12 x 40mm long	1
10.	Hexagon socket button head screw M12 x 16mm long	1
11.	Spacer for link plate	1
12.	Clamp screw	1
13.	Hexagon socket capscrew M8 x 16mm long	2
14.	Hexagon socket capscrew M8 x 35mm long	2

* **Note** :- When ordering riving knife specify saw diameter.

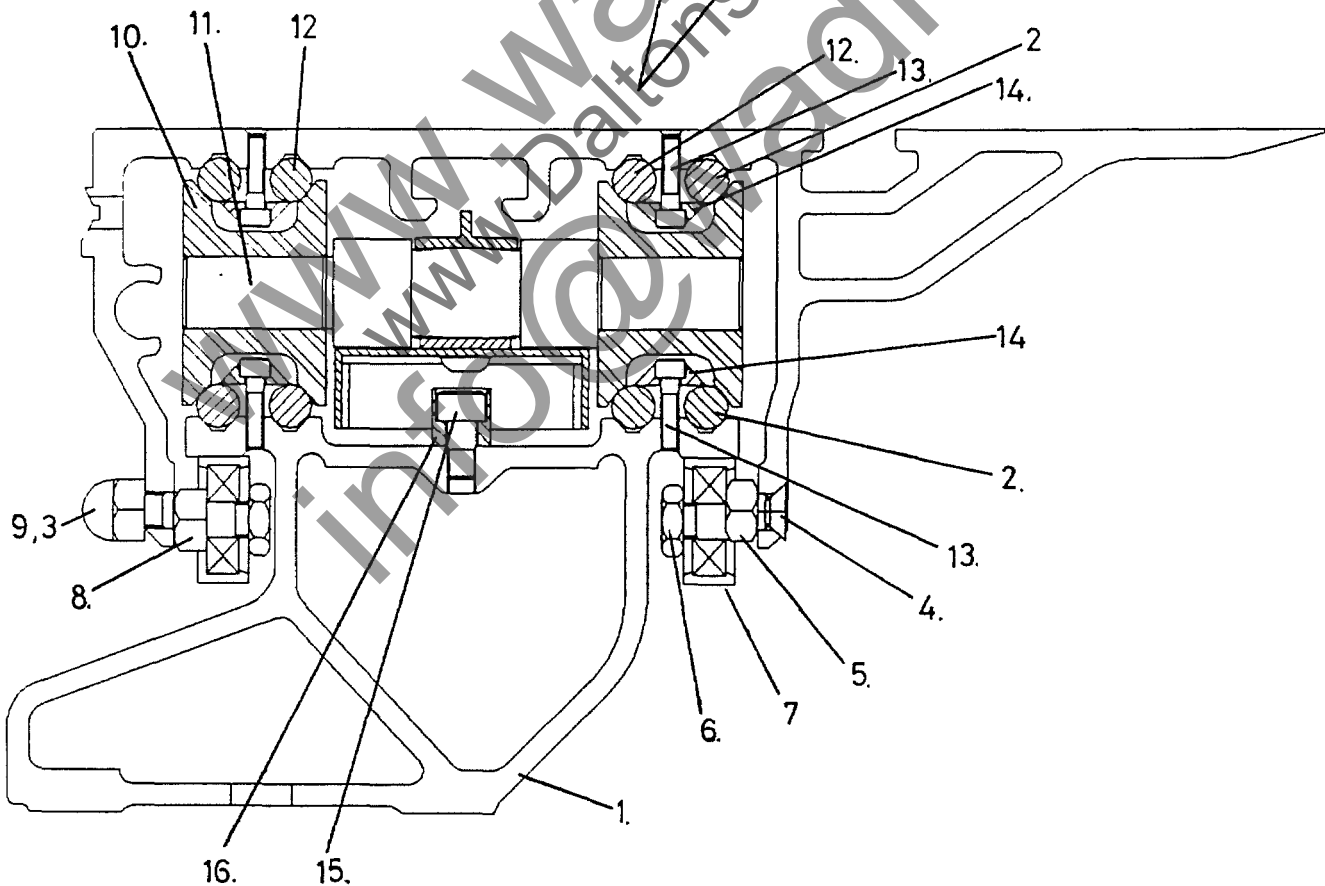
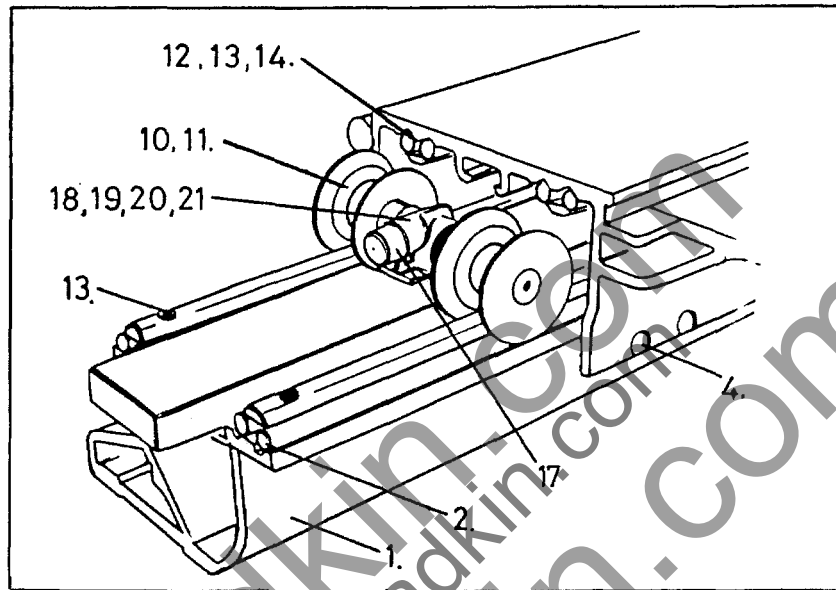

FIG 7 SLIDING TABLE ASSEMBLY

7. SLIDING TABLE

Ref. No	Description	No. Off
1.	Beam 1600mm long	CP160 1
	2600mm long	CP260 1
	3200mm long	CP320 1
2.	Sliding table	CP160 6
		CP260 6
		CP320 6
3.	Plain washer M10	6
4.	Hexagon socket capscrew M8 x 12mm long	6
5.	Roller eccentric	6
6.	Locknut M10	12
7.	Inner slide arm roller	12
8.	Eccentric pin under table roller	6
9.	Domed nut M10	6
10.	Diabolo roller	4
11.	Diabolo roller shaft	2
12.	Slide table rod	CP160 2
		CP260 2
		CP320 2
13.	Hexagon socket capscrew M5 x 20mm long	CP160 44
		CP260 72
		CP320 88
14.	Slide rod clamp plate	CP160 4
		CP260 4
		CP320 8
15.	Hexagon socket capscrew M8 x 16mm long	2
16.	Stop for carriage	1
17.	Rubber stop	2
18.	Trapping bracket	2
19.	Self locking nut M8	2
20.	Trapping bracket spacer	2
21.	Socket button head screw M8 x 16mm long	4

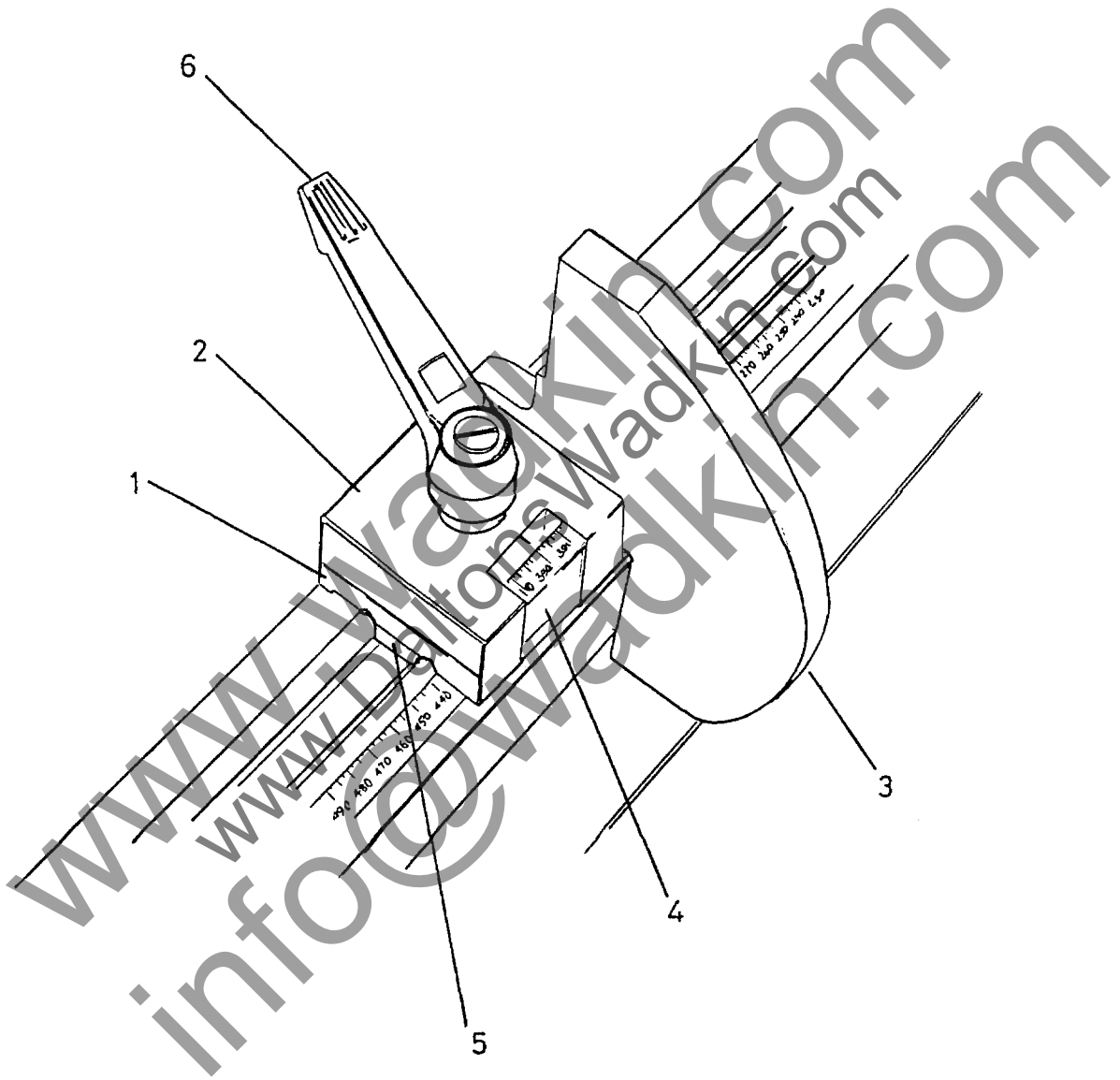

FIG 8 TURN-OVER STOP

8. TURN-OVER STOPS

Ref. No	Description	No. Off
1.	Slide block	1
2.	Turn-over stop body	1
3.	Turn-over stop	1
4.	Turn-over stop pointer	1
5.	Turn-over stop shoe	1
6.	Kipp handle 10mm	1

www.wadkin.com
www.DaltonsWadkin.com
info@wadkin.com

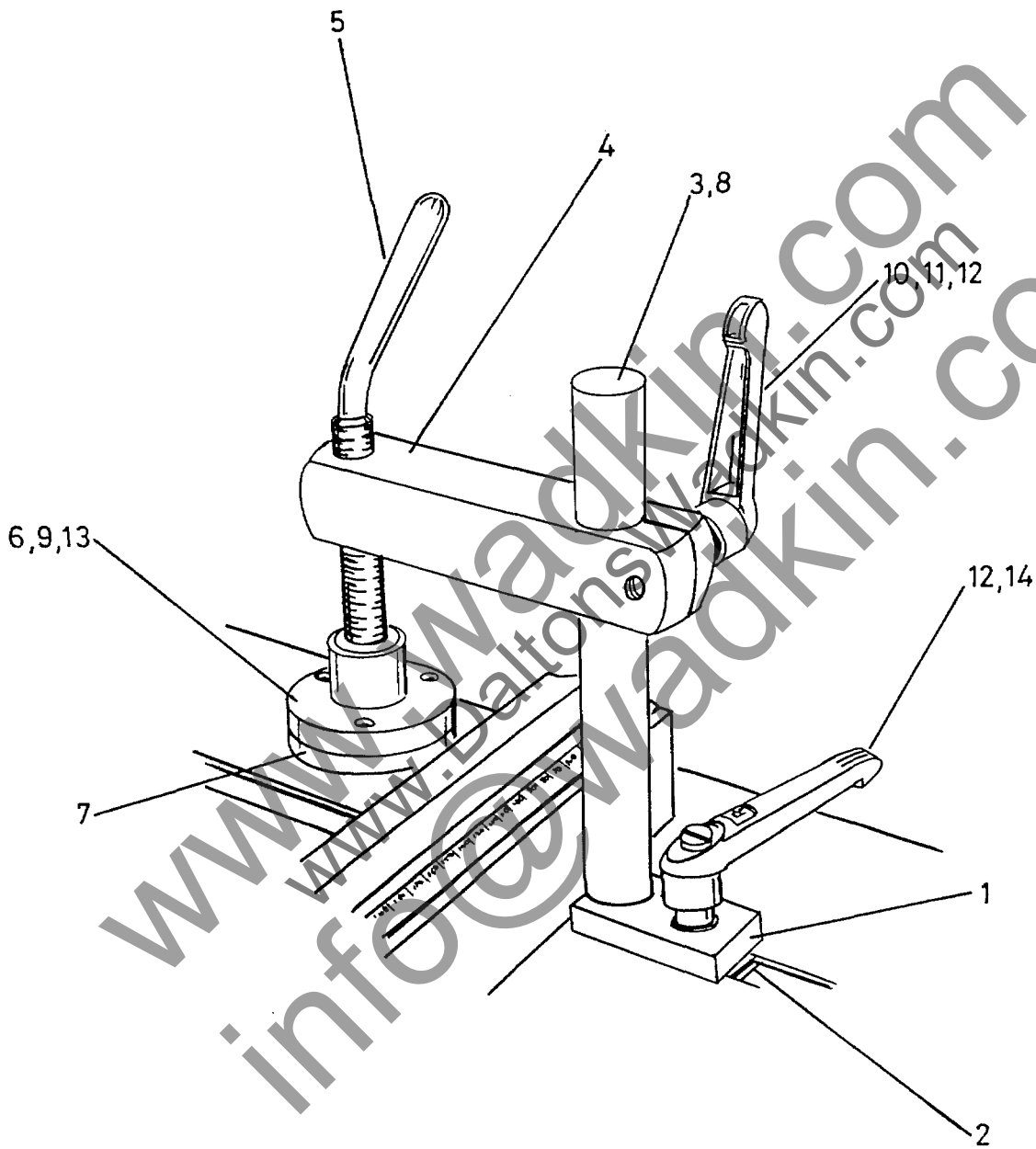

FIG 9 MANUAL CLAMP (OPTION)

9. MANUAL CLAMP

Ref No	Description	No. Off
1.	Clamp for key	1
2.	Key	1
3.	Pillar	1
4.	Clamp bar	1
5.	Clamp screw	1
6.	Clamp pad body	1
7.	Clamp pad	1
8.	Hexagon socket capscrew M10 x 40mm long	1
9.	Hexagon socket countersunk screw M6 x 20mm long	3
10.	Stud M10 x 40mm long	1
11.	Plain washer 10mm	1
12.	Kipp handle 10mm	2
13.	'O' Ring Ref RMO 146/24	1
14.	Stud M10 x 35mm long	1

www.wadkin.com
www.DaltonsWadkin.com
info@wadkin.com

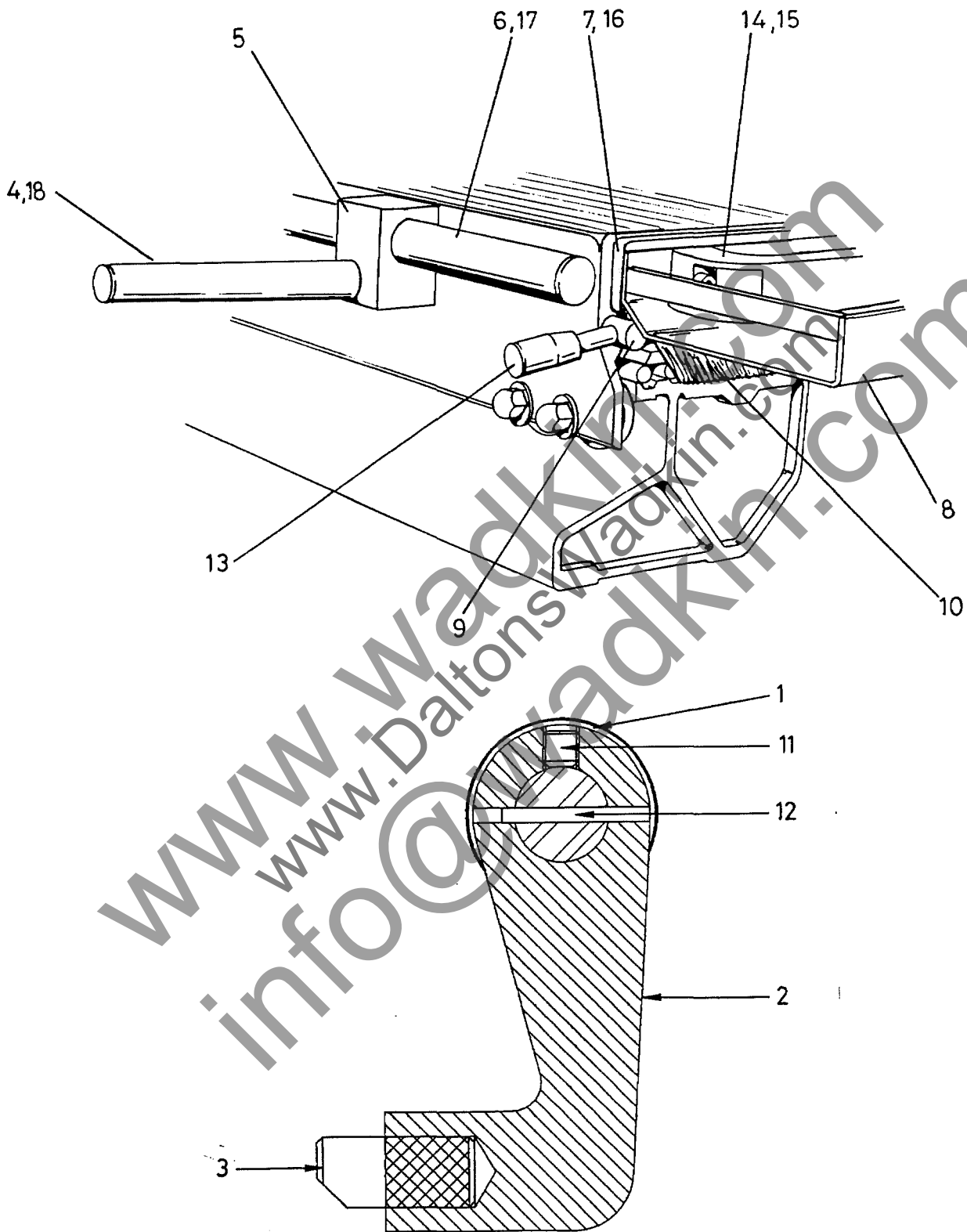

FIG 10 HANDLES AND LOCK FOR SLIDING TABLE

10. HANDLES AND LOCK FOR SLIDING TABLE

Ref. No	Description	No. Off
1.	Washer	1
2.	Stop bracket for sliding table	1
3.	Locating pin for table stop	1
4.	Push handle	1
5.	Handle block	1
6.	Support bar	1
	CP160	1
	CP260	1
	CP320 (front)	1
	CP320 (rear)	1
7.	Table end plate	1
	(front)	1
	(rear)	1
8.	Table end cover	1
	(front)	1
	(rear)	1
9.	Table locking shaft	1
	CP160	1
	CP260	1
	CP320	1
10.	Brush for sliding table	2
11.	Hexagon socket grub screw M6 x 6mm long	1
12.	Tension pin dia 3mm x 24mm long	1
13.	Lever arm	1
14.	'Elesa' Handle Ref M443/150N	2
15.	Hexagon socket capscrew M6 x 12mm long	4
16.	Hexagon socket capscrew M8 x 12mm long	4
17.	Hexagon socket capscrew M8 x 25mm long	6
	CP160	6
	CP260	9
	CP320	11
18.	Hexagon socket capscrew M10 x 45mm long	1

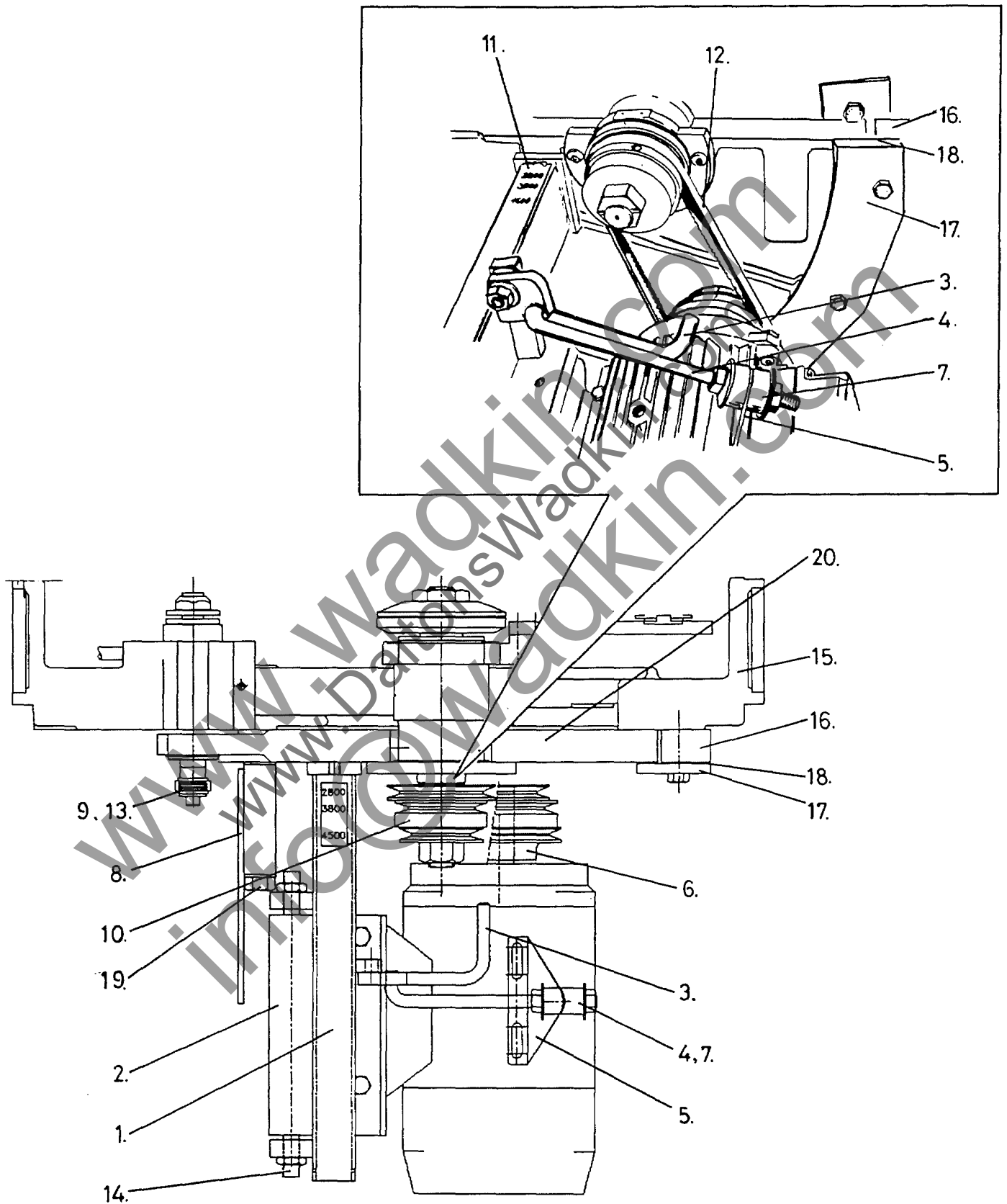

FIG. 11. MOTOR MOUNTING AND SWING.

11.MOTOR MOUNTING AND SWINGS

Ref. No	Description	No. Off
1.	Motor pivot bracket	1
2.	Motor plate	1
3.	Tension handle assembly	1
4.	Tension bar	1
5.	Tension bracket	1
6.	Motor pulley	1
7.	Tension buffer	2
8.	Motor platform - scoring saw	1
9.	Score spindle pulley	1
10.	Saw spindle pulley	1
11.	Speed indication lable	1
12.	Main saw drive belt ref SPZ 710	1
13.	Poly-vee belt for scoring saw ref 460J4	1
14.	Pivot screw	2
15.	Truion	1
16.	Packing piece	1
17.	Trapping plate	1
18.	Shim	6
19.	Platform pivot stud	1
20.	Rise and fall bracket	1
21.*	Scoring saw motor pulley	1

* Not illustrated

LIFTING AND TRANSPORTATION

Dimensions and Weight for Transportation

	CP160	CP260	CP320
Length	2200mm	2900mm	3520mm
Width	1600mm	1600mm	1600mm
Height	1100mm	1100mm	1100mm
Weight	1100kg	1150kg	1200kg

Unloading

Ensure that all lifting equipment used is capable of lifting the weight of the machine as a minimum.

Three lifting eyes secured to the sides of the machine ensure the slings are kept clear of the body. Whilst moving avoid jolting or vibrating the machine.

WARNING:- Do not walk or stand underneath a raised machine.

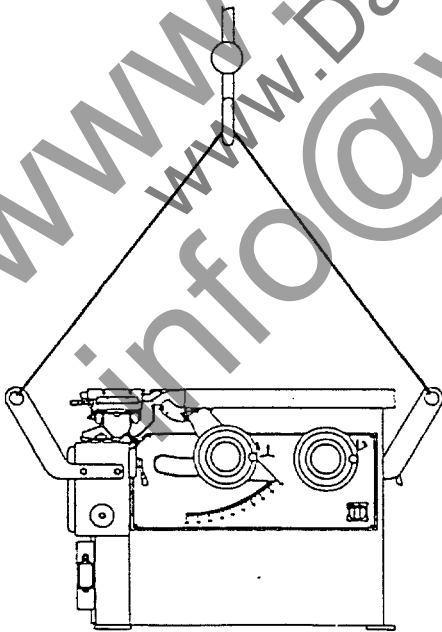

Unpacking

To reduce the size of the machine for transport several items have been removed and individually packed. These items as well as the main machine should be unwrapped and checked to make sure no damage has occurred in transit.

Check machine is complete with all items as listed below.

Note:- Extras or customer specials are not listed here and should be checked against order.

- Outrigger table
- Turnover stops - 2 off
- Crosscut fence
- Main saw
- Scoring saw
- Riving knives
- Rip fence guide bar
- Rip fence body
- Rip fence
- Locking plate for crownguard bar arm
- Crown guard
- Crown guard extraction adaptor
- Crown guard arm
- Side extension table
- Leg for side extension table
- Outer panel support
- Rear extension table (Optional)
- Legs for above- 2 off

Tool kit comprising of:-

- Push stick (C.E machines only)
- Instruction manual
- 46mm A/F spanner
- 32mm A/F spanner
- 17/19mm A/F double ended spanner
- 8mm long arm allen key
- 6mm allen key
- 5mm allen key
- 3mm allen key
- Control panel key

CP

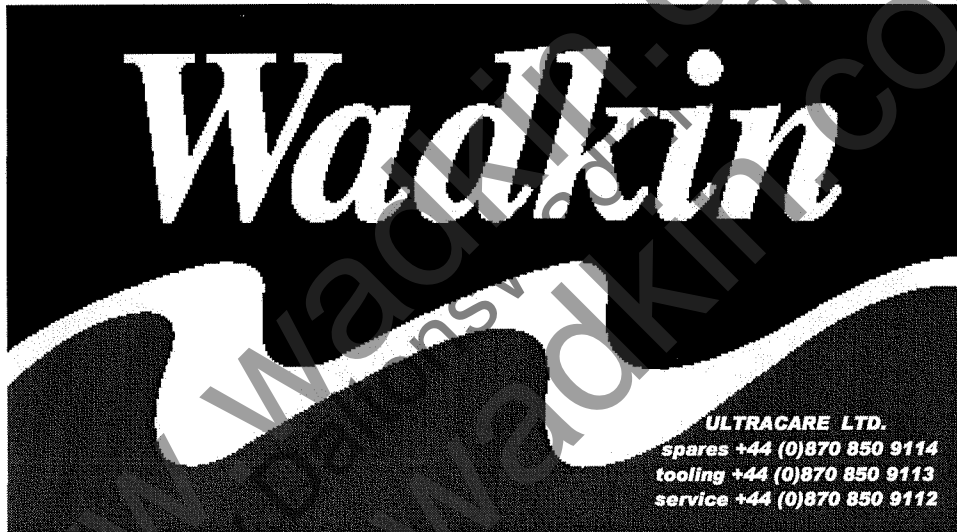

www.wadkin.com
www.wadkin.com
info@wadkin.com