

**OPERATING INSTRUCTIONS
MAINTENANCE
AND PARTS LIST BOOK**

**WOOD TURNING LATHE
TYPE 6" BZL**

www.DaltonsWadkin.com

WOOD TURNING LATHE TYPE 6" BZL

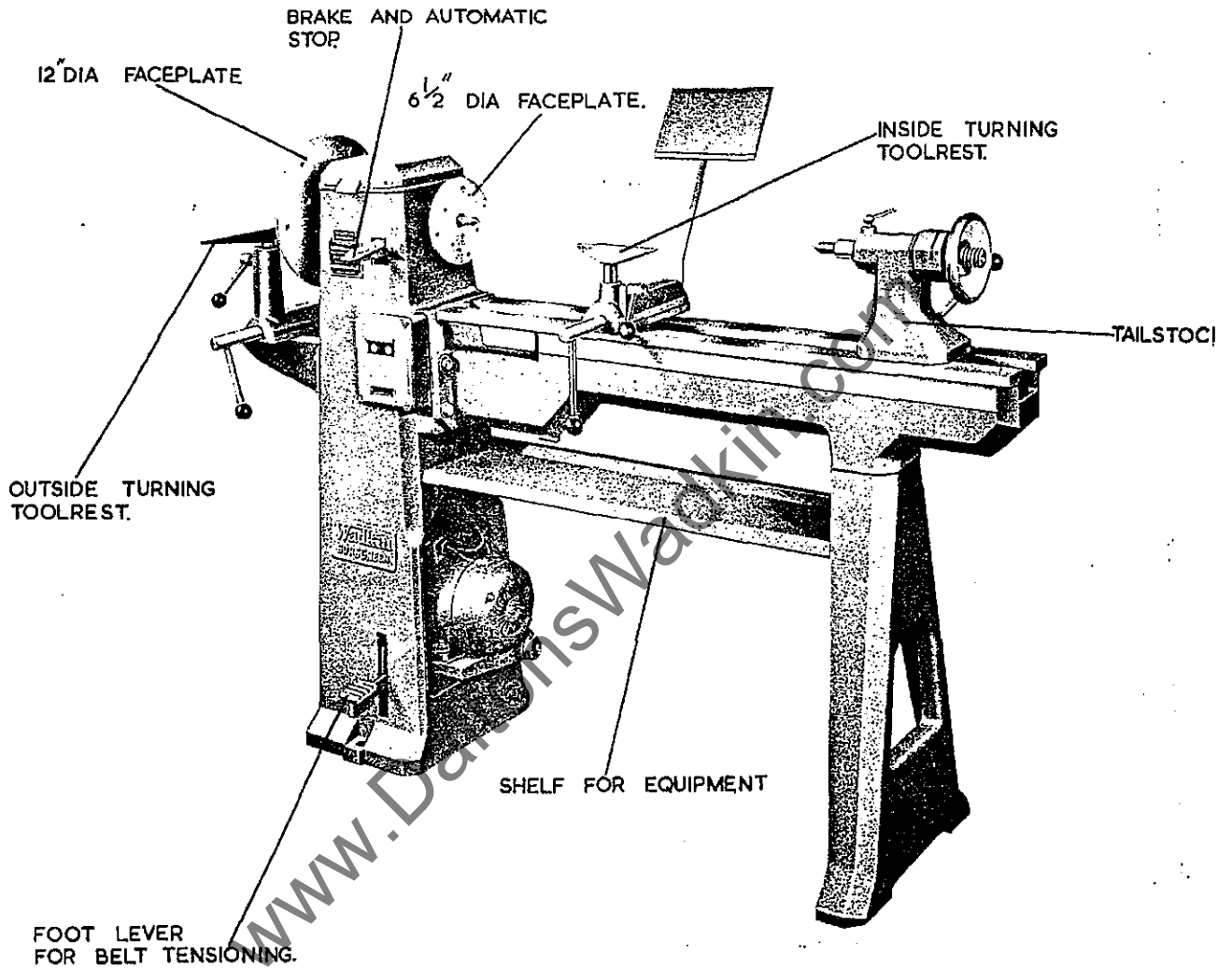

FIG. I.

S P E C I F I C A T I O N

Height of centres*..	6"	155 mm
Will take between centres	36"	915 mm
Height from floor to centres	40"	1015 mm
Diameter turned with gap bed..	18"	460 mm
Width turned with gap bed	8 1/2"	215 mm
Diameter turned over handrest.	8 1/2"	215 mm
Speeds of spindle...	425, 800, 1400, 2300 r.p.m.	
Horse power of motor	1	
Speed of motor.	1500 r.p.m.	
Floor space ...	50" x 16"	1270 m.m x 410 m.m
Net weight ...	600 lb.	270 kg.
Gross weight...	780 lb.	350 kg.
Shipping dimensions.	42 cu.ft.	1.2 cu.m.

* Note: Machine will swing a maximum of 12 1/2" (317 mm) over bed between centres.

INSTALLATION

Remove protective coating from bright parts by applying a cloth soaked in paraffin, turpentine or other solvent.

When the machine is cased for export the outside turning assembly (if fitted) is removed and packed individually. Remove and re-assemble as shown in Fig. 1.

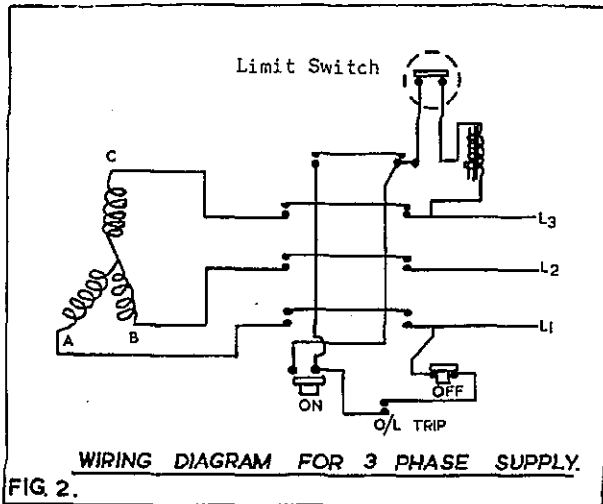

FIG. 2.

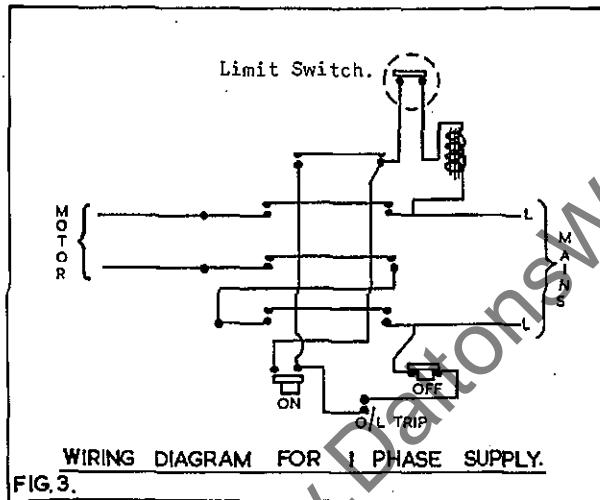

FIG. 3.

WIRING DETAILS

The motor and control gear have been wired in before despatch. All that is required is to connect the power supply to the starter.

Points to note when connecting to power supply:-

1. Check the voltage, phase and frequency correspond to those on the motor plate, also the correct coils and heaters are fitted to the starter.
2. It is important that the correct cable is used to give the correct voltage to the starter as running on low voltage will damage the motor.
3. Check the main line fuses are of the correct capacity. See list below.
4. Connect the line leads to the appropriate terminals. See Fig. 2 for three phase supply. See Fig. 3 for single phase supply.
5. Check all connections are sound.
6. Check the rotation of the motor for the correct direction. If this is incorrect for three phase supply reverse any two of the line lead connections.

VOLTAGE	PHASE	S.W.G. TINNED COPPER WIRE.	AMPS
220	3	25	15
340/420, 550	3	30	8.5
200/250	1	23	20

LUBRICATION

See Fig. 4 for lubrication instructions. It is advisable to keep all bright parts covered with a thin film of oil to prevent rusting. The bed should also be kept clear of any chippings for ease of operation of the toolrest and the tailstock.

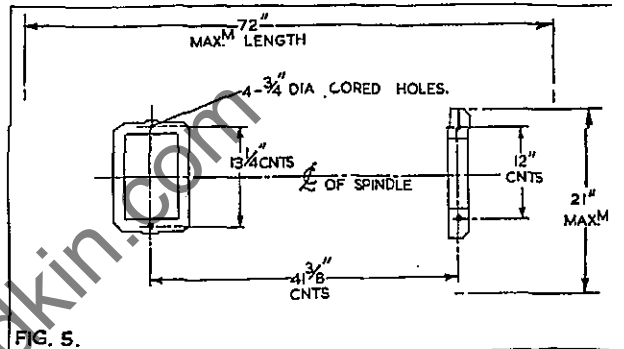
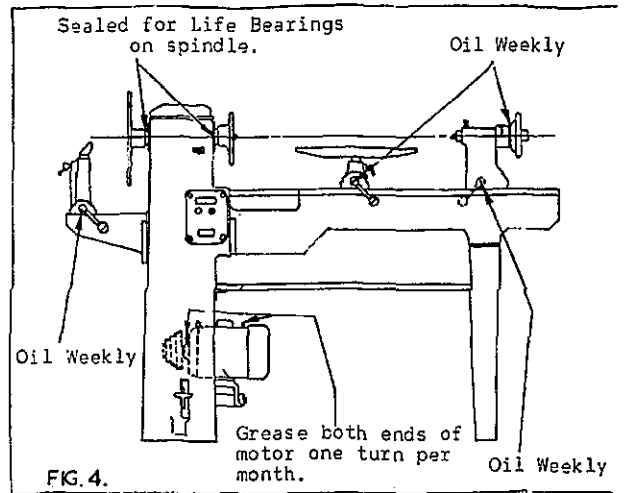

FOUNDATION

See Fig. 5 for bolt positions and clearances required. When installing the machine level the bed by packing under the feet. Foundation bolts are not supplied with the machine except by special order.

BELT TENSION

The drive is by means of a vee belt from a 1 HP motor mounted on a hinged bracket. A foot lever removes the tension on the belt for speed changing.

To change speed the undermentioned procedure should be followed:-

1. Brake the machine and swing the lid clear of the pulley at the top of the machine. This will automatically cut off the supply to the motor.
2. Release the tension on the belt by moving the foot lever up the ratchet.
3. Select the required speed on the stepped spindle pulley.
4. Select the required speed on the stepped motor pulley through the aperture "A" in the side of the trunk, as shown in Fig. 6.
5. Re-tension the belt by moving foot lever down the ratchet until the required tension is reached.

To replace a worn or broken belt the undermentioned procedure should be followed:-

1. Swing the lid clear of the pulley at the top of the machine.
2. Remove the outside turning faceplate if fitted.
3. Slacken socket head grubscrew "A" securing the spindle adaptor to the spindle, as shown in Fig.
4. Slacken the two socket head grubscrews "B" securing the spindle pulley to the spindle.
5. Tap out the spindle in the direction of the arrow "C" taking care not to damage the threads on the end of the spindle, also to hold the spindle pulley before the spindle is completely withdrawn.
6. The old vee rope can now be removed and the new belt put on.

The above mentioned procedure should be reversed to re-assemble.

To line the spindle pulley up with the motor pulley, remove the socket head grubscrew "B", which is at 90° to the keyway and line this up with the dimple which is in the spindle, then re-lock in position. This will ensure that the spindle pulley and the motor pulley are in line.

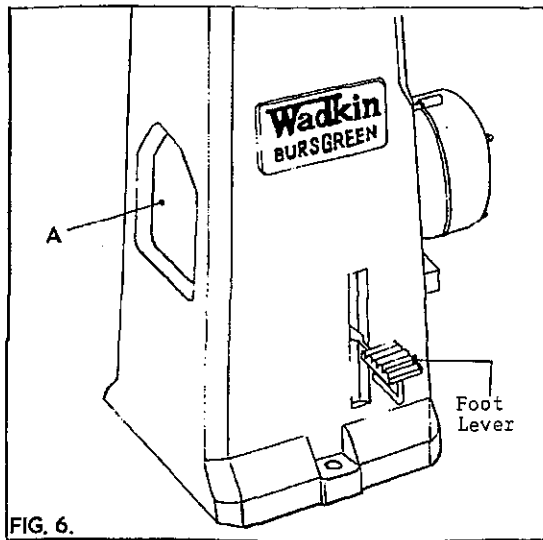

FIG. 6.

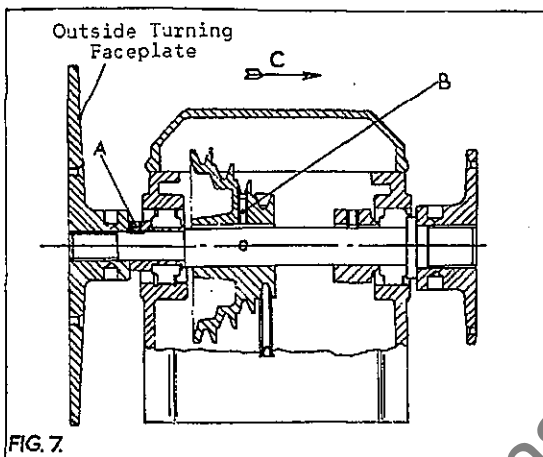

FIG. 7.

CARE OF THE BED

The bed of this lathe has been precision ground to provide a smooth and true surface for the tailstock and the toolrest assemblies to slide on. Care should be taken not to damage the surface of the bed through careless handling of the tools as this will affect the accuracy of the machine, also the action of the toolrest and tailstock.

Keep the bed clear of chippings and wipe it frequently with an oily rag for ease of operation and to prevent rusting.

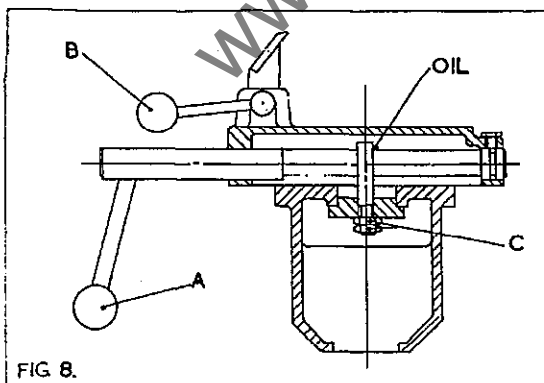

FIG. 8.

OPERATION OF THE TOOLREST

The toolrest has a quick action lock for ease and quickness of positioning in any position on the bed. To lock the entire toolrest assembly to the bed lock the ball handle "A", in Fig. 8.

To lock or unlock the toolrest only screw the ball handle "B" (left hand thread).

The toolrest is locked to the bed by means of an eccentric spindle, if this does not lock correctly or it does not unlock sufficiently for it to move freely along the bed, the two $\frac{1}{2}$ " whit. locknuts "C" should be adjusted by the required amount until it locks correctly.

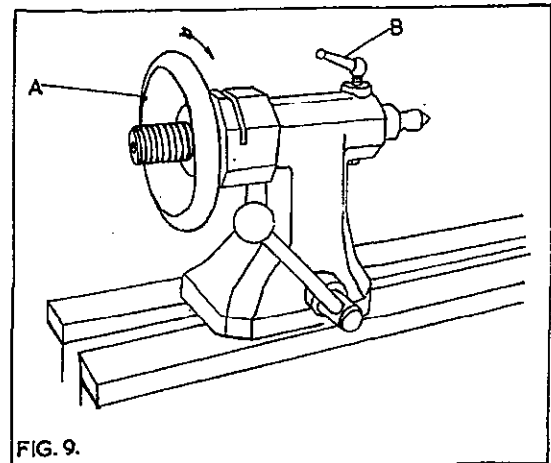

FIG. 9.

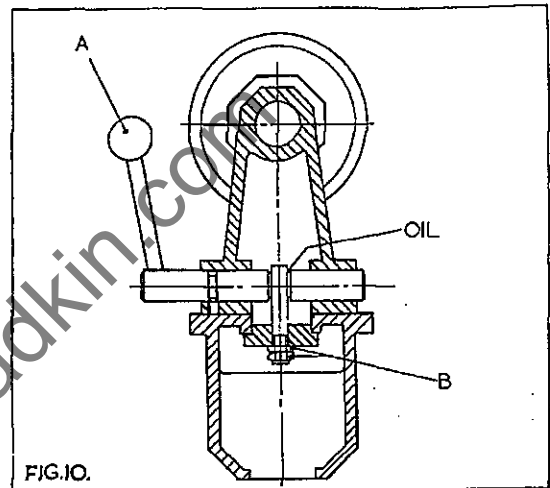

FIG. 10.

OPERATION OF THE TAILSTOCK

The movement of the tailstock spindle is controlled by the handwheel "A", in Fig. 9. Turning the handwheel in the direction of the arrow moves the tailstock spindle towards the workpiece. The tailstock spindle is locked in position by means of the ball lever "B" at the front of the tailstock. The spindle must be unlocked at all times before attempting to move it in or out by means of the handwheel.

The tailstock assembly is locked to the bed by means of the ball handle "A" at the rear of the tailstock, as shown in Fig. 10. If the tailstock assembly does not lock correctly or it does not unlock sufficiently for it to move freely along the bed, the two $\frac{1}{2}$ " whit. locknuts "B" should be adjusted by the required amount until it locks correctly.

All centres with a No. 2 morse taper shank will fit into the taper bore in the tailstock spindle. Before inserting the centres make sure they are free from burrs, rust and dirt. Place a few drops of oil on the shanks of all centres before inserting into position. The centres can be ejected from the tailstock spindle, by means of the knock out rod provided, being placed down the centre of the spindle and given a sharp tap.

HEADSTOCK SPINDLE UNIT

The spindle is threaded at both ends to receive chucks and faceplates. All centres with a No. 2 morse taper shank will fit into the taper bore in the spindle end, which is over the bed.

The centre can be ejected from the spindle by means of the knock out rod provided, being placed down the centre of the spindle and given a sharp tap.

OPERATION OF THE OUTSIDE TURNING REST (EXTRA)

The outside turning rest assembly can be quickly positioned by means of the single lever "A" in Fig. 11. To lock or unlock the toolrest only screw the ball handle "B" (right hand thread).

The toolrest lock to the bed is identical to that for the inside toolrest and if adjustment is necessary refer to Fig. 8 for instructions.

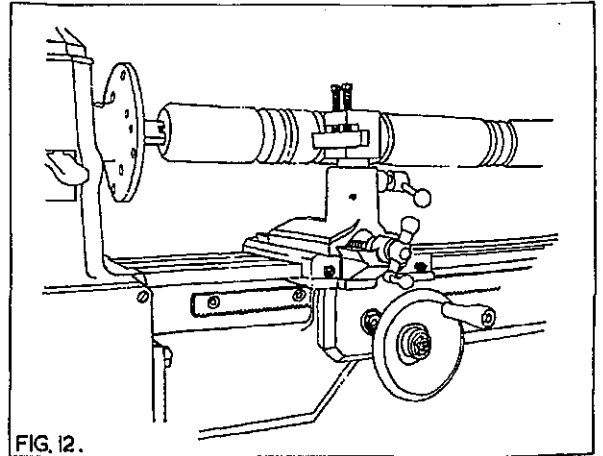
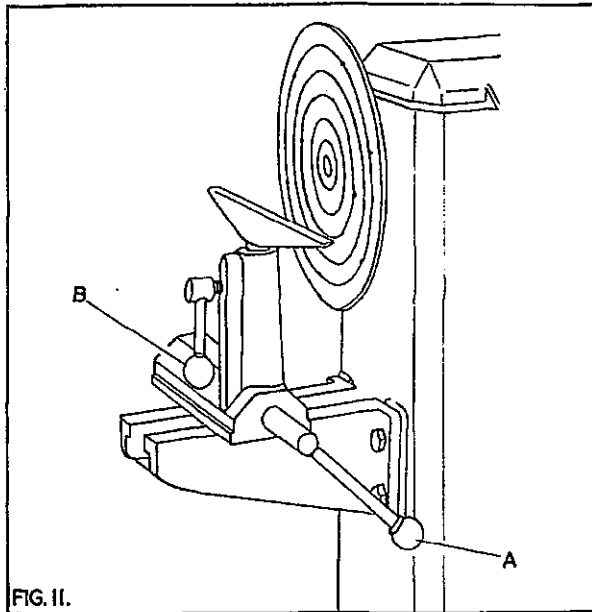

COMPOUND TOOL AND SLIDE REST

The machine can be fitted with a rack operated compound tool and slide rest, as shown in Fig. 12, only before despatch from the works.

The maximum diameter which can be swung over the toolholder is 8 $\frac{3}{4}$ " (222 m/m).

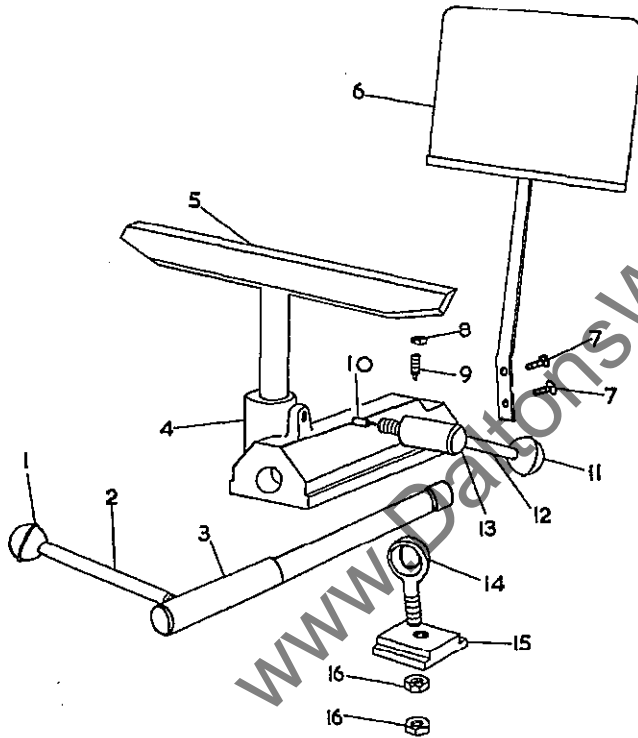

INSIDE TURNING ASSEMBLY

Ref.No.	Part No.	No.off	Description
1.	Patt.No.30	1	1 $\frac{1}{4}$ " dia. plastic ball, $\frac{1}{2}$ "whit.
2.	A-1023/36	1	Locking handle for eccentric bracket (13 $\frac{1}{2}$ " long).
3.	B-1023/30	1	Eccentric for toolrest
4.	C-1023/8	1	Bracket for standard turning
5.	C-1023/15	1	Toolrest for standard turning
6.	B-1023/40	1	Drawing holder.
7.		2	3/16" whit. x $\frac{1}{2}$ " long round head screw.
8.		1	$\frac{3}{8}$ " whit. locknut.
9.	A-1026/50	1	$\frac{3}{8}$ " whit. pipscrew.
10.	A-1023/45	1	Brass bot for toolrest locking handle.
11.	Patt.No.30	1	1 $\frac{1}{4}$ " dia. plastic ball, $\frac{3}{8}$ "whit
12.	A-1002/90A	1	Locking handle.
13.	A-1023/59	1	Locking handle for standard toolrest.
14.	A-1023/32	1	Eyebolt for locking eccentric
15.	A-1023/26	1	Clamp plate.
16.		2	$\frac{1}{2}$ " whit. locknut.

NOTE:- When ordering replacement parts quote Part No. and Serial No. of the machine.

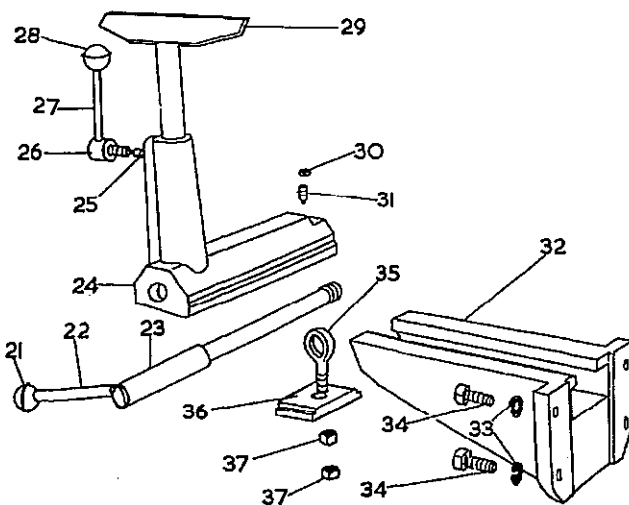

OUTSIDE TURNING ASSEMBLY (EXTRA)

Ref.No.	Part No.	No.off	Description
21.	Patt.No.30	1	1 $\frac{1}{4}$ " dia. plastic ball, $\frac{1}{2}$ "whit
22.	A-1023/36	1	Locking handle for eccentric bracket (15 $\frac{1}{2}$ " long).
23.	B-1023/30	1	Eccentric for toolrest
24.	C-1023/9	1	Bracket for outside turning.
25.	A-1023/45	1	Brass bot for toolrest locking handle.
26.	A-1023/35	1	Locking handle for outside toolrest.
27.	A-1002/90A	1	Locking handle.
28.	Patt.No.30.	1	1 $\frac{1}{4}$ " dia. plastic ball, $\frac{3}{8}$ "whit
29.	C-1023/16	1	Toolrest for outside turning
30.		1	$\frac{3}{8}$ " whit. locknut.
31.	A-1026/50	1	$\frac{3}{8}$ " whit. pipscrew.
32.	C-1023/5	1	Bed for outside turning.
33.		4	$\frac{1}{2}$ " spring washer.
34.		4	$\frac{1}{2}$ " whit. x $\frac{1}{4}$ " long hexagon head bolt.
35.	A-1023/32	1	Eyebolt for locking eccentric
36.	A-1023/26	1	Clamp plate.
37.		2	$\frac{1}{2}$ " whit. locknut.

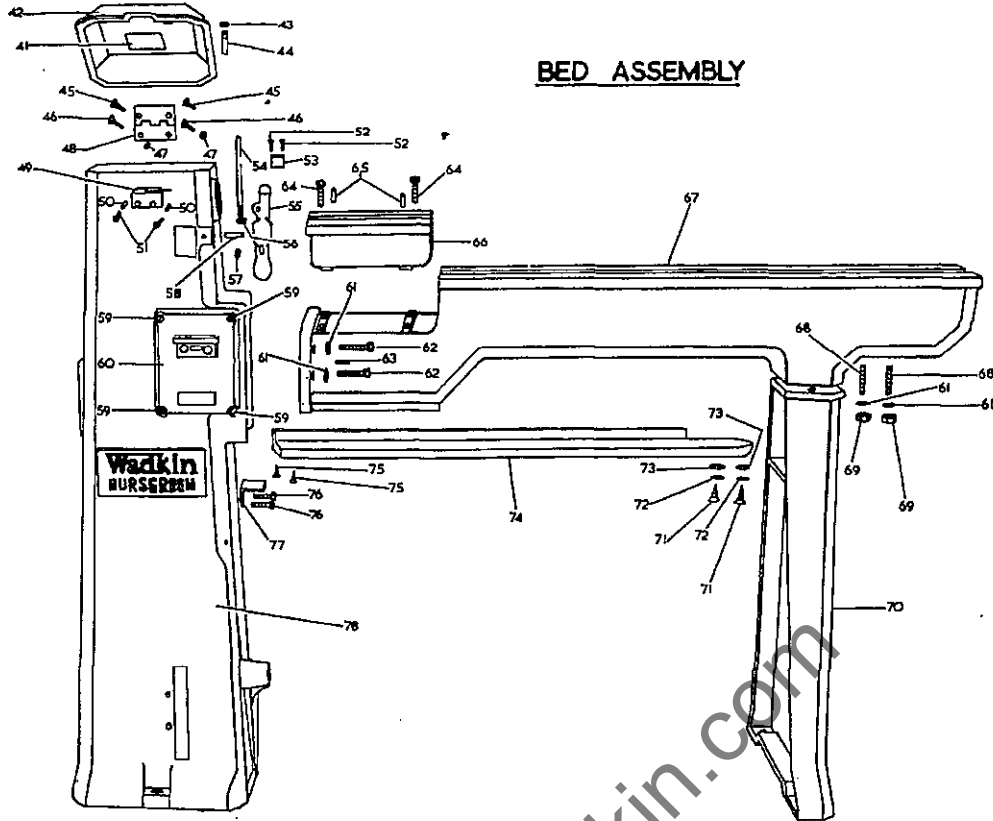

BED ASSEMBLY

Ref.No.	Part No.	No.off	Description	Ref.No.	Part No.	No.off	Description
41.	A-S-82	1	Plate for spindle speed.	61.		6	1/2" spring washer.
42.	C-1023/6	1	Lid for trunk.	62.		4	1/2" whit. x 1 1/2" long hexagon head bolt.
43.		1	3/8" whit. nut.	63.		2	5/16" dia. x 1" long fluted dowel.
44.	A-1023/46	1	Push rod for limit switch.	64.		2	3/8" whit. x 1" long hexagon head bolt.
45.		2	1/2" whit. x 3/4" long countersunk screw.	65.		2	1/4" dia. x 1" long fluted dowel.
46.		2	1/4" whit. x 1" long countersunk screw.	66.	B-1023/20	1	Gap bed insert.
47.		2	1/2" whit. nut.	67.	D-1023/2	1	Straight bed.
48.		1	3" steel hinges.	68.	D-1023/19	1	Gap bed.
49.	CYW-2	1	Burgess limit switch. <i>Kit #6 III</i>	69.		2	1/2" whit. x 1 1/2" long stud.
50.	A-1023/43	2	Brush for limit switch.	70.	D-1023/3	2	1/2" whit. nut.
51.		2	3/16" whit. x 1 1/2" long cheese head screw.	71.		1	Leg.
52.		2	3/16" countersunk copper rivet	72.		2	No. 8 x 1 1/4" long countersunk wood screw.
53.		2" long	Ferodo brake lining.	73.		2	1/4" washer.
54.	A-1023/41	1	Push rod for brake.	74.		2	5/16" washer.
55.	B-1023/12	1	Brake lever.	75.		1	Wood shelf.
56.		1	5/16" whit. nut.	76.		2	No. 6 x 3/4" long countersunk wood screw.
57.		1	1/4" whit. x 1/2" long socket head grub screw.	77.	B-1023/37	1	Angle iron for shelf.
58.	A-1023/22	1	Brake lever pivot pin.	78.	E-1023/1	1	Trunk.
59.		4	1/4" whit. x 3/4" long cheese head screw.				
60.	44ADS/FO	1	MEM Starter (50 cycles, 3 phase supply).				
	82ADS/FO	1	MEM Starter (50 cycles, 1 phase supply).				
	AT3	1	Brook Starter (60 cycle, 3 phase supply).				

NOTE: When ordering replacement parts quote Part No. and Serial No. of the machine.

MOTOR MOUNTING ASSEMBLY

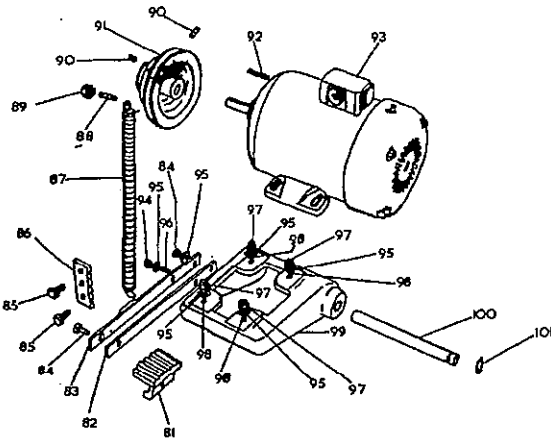

Ref.No.	Part No.	No.off	Description
81.	B-1023/21	1	Foot for belt tensioning.
82.	B-1023/23	1	Lever for belt tensioning (without turnover).
83.	B-1023/23	1	Lever for belt tensioning (with turnover).
84.		2	5/16" whit. x 3/4" long hexagon head bolt.
85.		2	3/8" whit. x 3/4" long hexagon head bolt.
86.	A-1023/33	1	Ratchet plate for belt tensioning.
87.	A-1023/39	1	Spring for belt tensioning.
88.		1	1/2" whit. x 1" long stud.
89.		1	1/2" whit. aerotight nut.
90.		2	5/16" whit. x 3/8" long socket head grub screw.
91.	B-1023/11	1	Motor pulley.
92.		1	3/16" wide x 1 1/2" long key.
93.		1	Brook motor, T14, 1500 r.p.m. (50cycle, 3phase supply).
		1	Brook motor, C12, 1500 r.p.m. 1/2 HP. (50cycle, 1phase supply)
		1	Brook motor, T14, 1800 r.p.m. 1 HP. (60cycle, 3phase supply).
94.		1	5/16" whit. nut.
95.		6	5/16" washer.
96.		1	5/16" whit. x 1" long stud.
97.		4	5/16" whit. aerotight nut.
98.		4	5/16" whit. x 1 1/8" long stud.
99.	C-1023/7	1	Motor bracket.
100.	A-1023/13	1	Motor bracket pivot pin.
101.		1	3/4" external circlip.

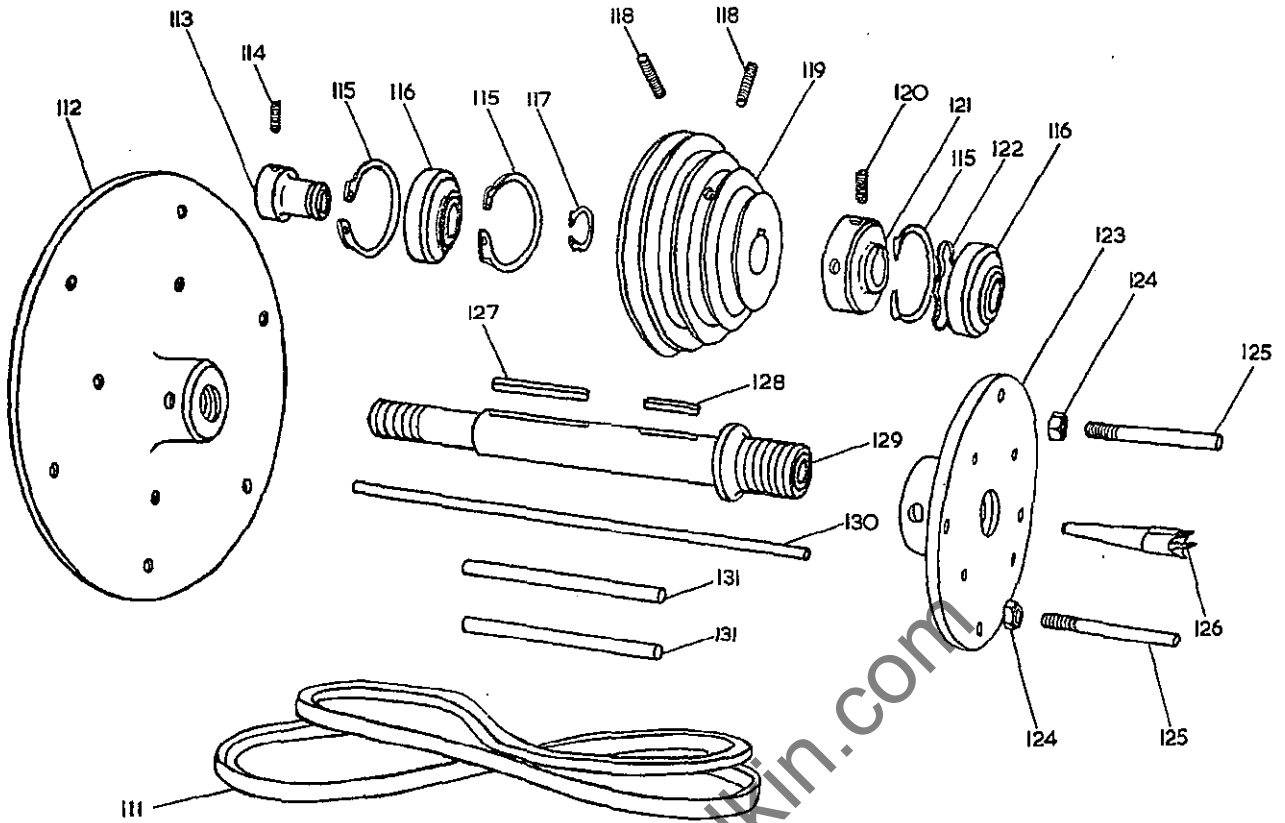

SPINDLE ASSEMBLY

Ref.No.	Part No.	No.off	Description	Ref.No.	Part No.	No.off	Description
111.	A68	1	Vee belt.	121.	A-1023/14	1	Brake drum.
112.	B-1023/17	1	Faceplate for outside turning (extra).	122.	A-1023/80	1	Bumped washer.
113.	B-1023/28	1	Adaptor for spindle.	123.	B-1023/18	1	Faceplate for standard turning.
114.		1	3/8" whit. x 1/2" long socket head grub screw.	124.	A-1023/49	2	3/8" whit. nut.
115.		3	62 m/m "Seeger" internal circlip.	125.	A-1023/49	2	Driving peg.
116.	88506	2	SKF Bearing.	126.	A-1023/90	1	1/8" dia. four spur driving centre.
117.		1	30 m/m "Seeger" external circlip.	127.		1	5/16" wide x 3" long key.
118.		2	5/16" whit. x 3/8" long socket head grub screw.	128.		1	5/16" wide x 1 1/2" long key.
119.	B-1023/10	1	Spindle pulley.	129.	B-1023/27	1	Spindle.
120.		1	1/2" gas x 1/2" long socket head grub screw.	130	A-1023/37	1	Knockout rod for centres.
				131.	A-1023/38	2	Toggle bar.

NOTE:- When ordering replacement parts quote Part No. and Serial No. of the machine.

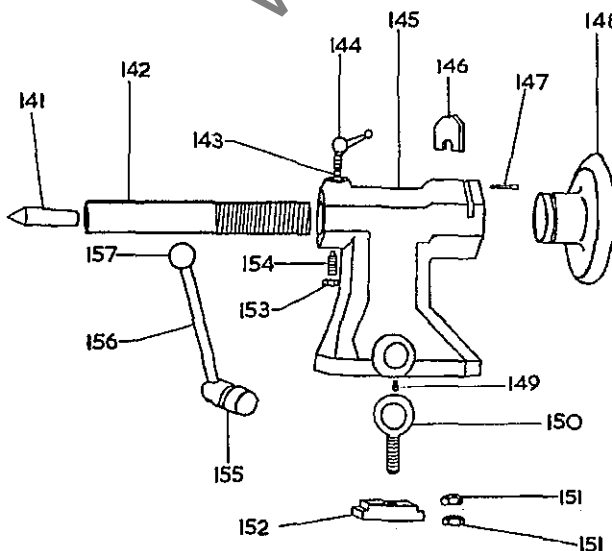

TAILSTOCK ASSEMBLY

Ref.No.	Part No.	No.off	Description
141.		1	Cone centre, No. 2 Morse taper centre.
142.	B-1023/24	1	Tailstock screw.
143.	A-1023/44	1	Brass bot for tailstock.
144.	B-S-1-B	1	3/8" whit. ball lever screw.
145.	C-1023/4	1	Tailstock.
146.	A-1023/34	1	Keep plate for tailstock screw.
147.		1	3/16" whit. x 1" long cheese head screw.
148.	C-1023/25	1	6" dia. handwheel for tailstock.
149.	A-1023/31	1	Pip screw (1/2" long).
150.	A-1023/32	1	Eyebolt for locking eccentric.
151.		2	1/2" whit. locknut.
152.	A-1023/26	1	Clamp plate.
153.		1	3/8" whit. nut.
154.	A-1023/31	1	Pip screw (3/8" long).
155.	B-1023/29	1	Eccentric for tailstock.
156.	A-1023/36	1	Locking handle for eccentric.
157.	Patt.No.30.	1	1/4" dia. plastic ball, 1/2" whit.

NOTE:- When ordering replacement parts quote Part No. and Serial No. of the machine.

Accessories for use on Wood Turning Lathes

ALL CENTRES ARE No. 2 MORSE TAPER

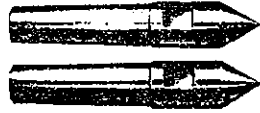

CONICAL CENTRES.



FOUR SPUR DRIVING CENTRES
 $\frac{3}{4}$ " DIA $\frac{1}{8}$ " DIA AND $\frac{1}{2}$ " DIA.



CUP CENTRE
 $\frac{1}{2}$ " DIA AND $\frac{3}{4}$ " DIA.



REVOLVING CENTRE
MODEL 'DB'

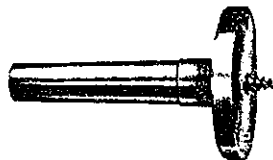

SCREW POINT DRIVING PLATE
 $\frac{1}{2}$ " DIA AND $3\frac{1}{2}$ " DIA.

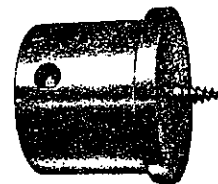

SCREW POINT CHUCK
3" DIA AND 4" DIA

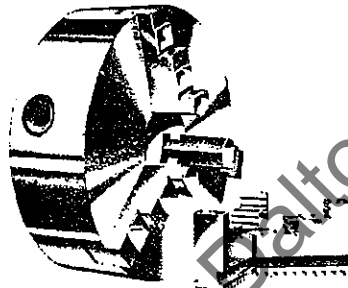

CHUCKS
4" DIA OR 6" DIA WITH 3 OR 4 JAWS

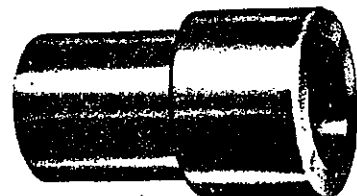

HOLLOW OR BELL CHUCK
1" DIA $\frac{1}{2}$ " DIA 2" DIA AND 2 $\frac{1}{2}$ " DIA

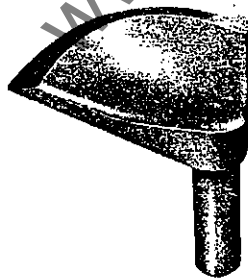

BOWL TURNING REST.

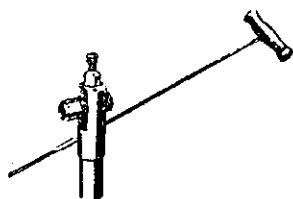

DEEP HOLE BORING EQUIPMENT.

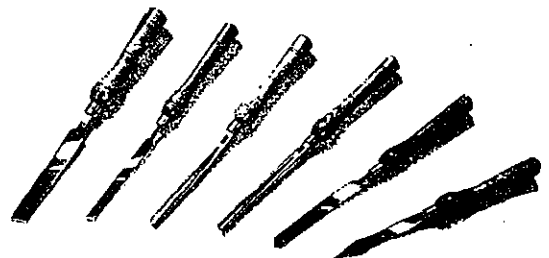

SET OF HAND TURNING TOOLS.

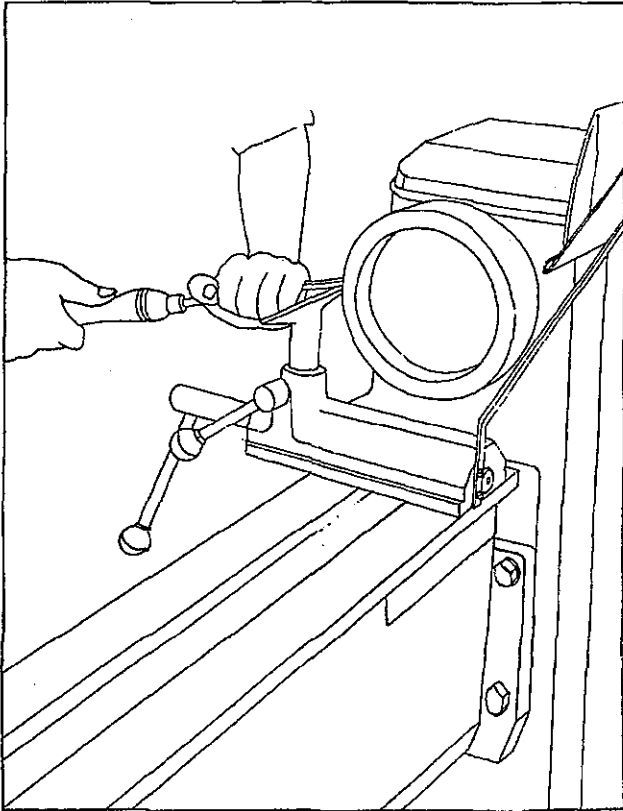

TURNING ON THE INSIDE FACEPLATE UP TO A MAXIMUM OF 18" DIA X 8½" WIDE (460MM X 215MM) WITH GAP BED.

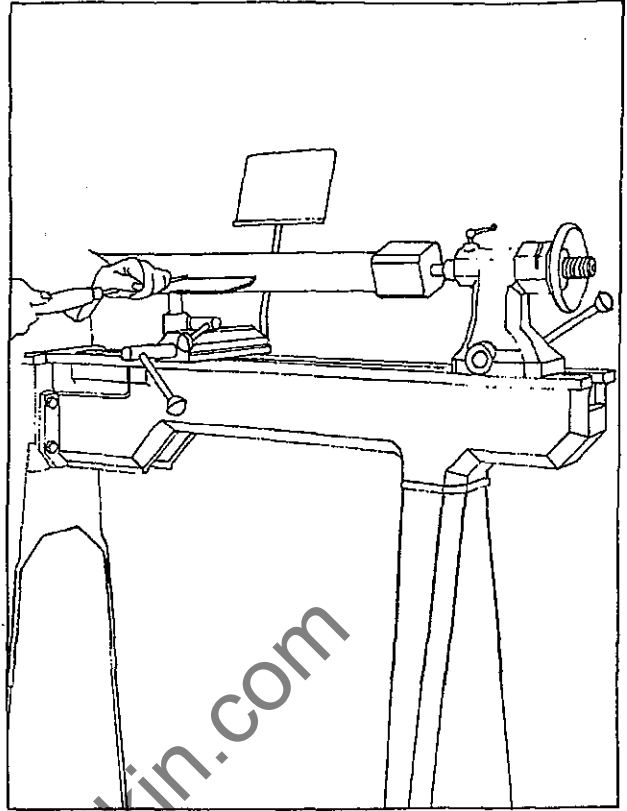

TURNING BETWEEN CENTRES UP TO A MAXIMUM OF 3FT (915MM)

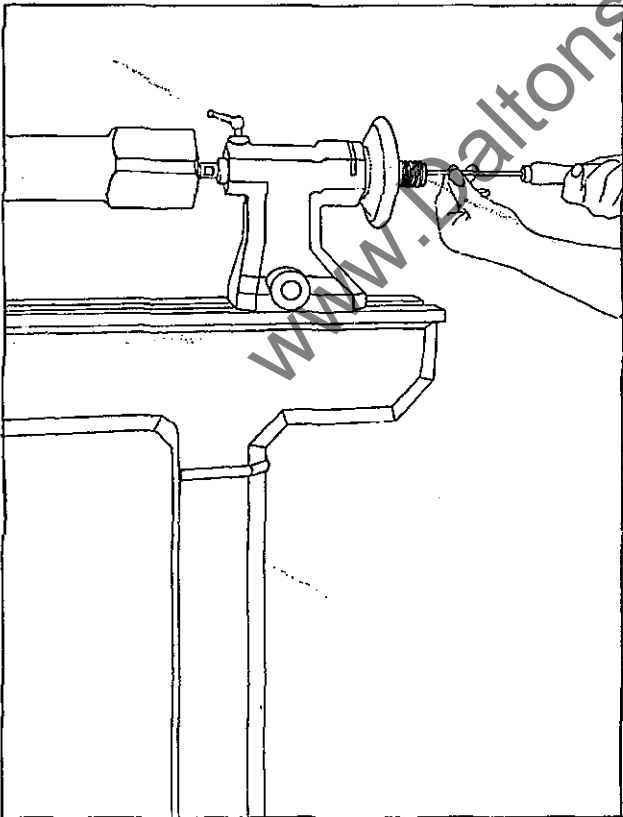

DEEP HOLE BORING CAN BE DONE EITHER THROUGH THE TAILSTOCK OR OFF A SPECIAL POST IN THE TOOLREST BRACKET

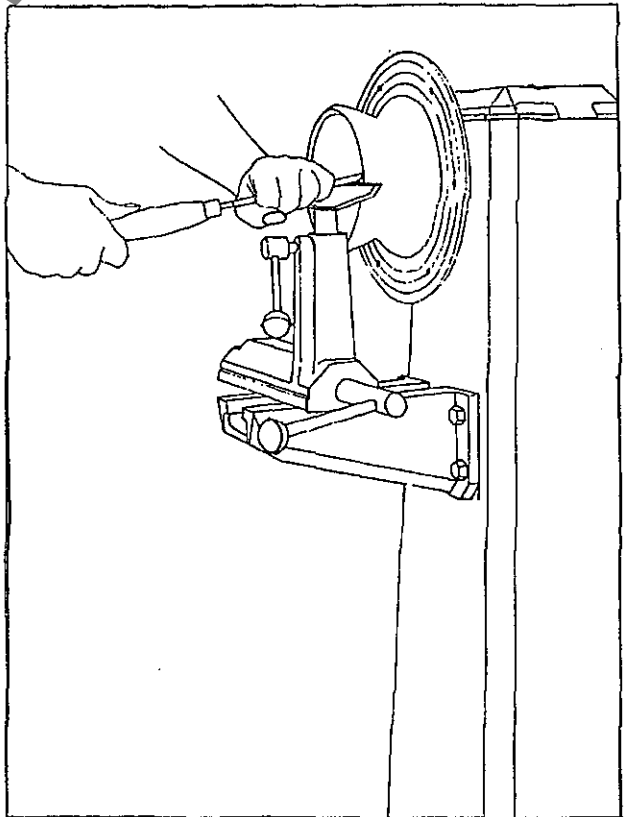

TURNING ON THE OUTSIDE FACEPLATE UP TO A MAXIMUM OF 20" DIA X 5" WIDE (508MM X 125MM)