

INSTRUCTION MANUAL FOR

60" BGP

SLIDING TABLE PANEL

SAWBENCH

Modifications are made to these books from time to time and it is important therefore that only the book sent with the machine should be used as a working manual

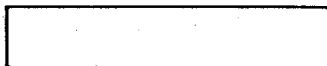

PLEASE INSERT SERIAL NUMBER OF MACHINE

INSTRUCTION MANUAL FOR

TR

60" BGP

12" Sliding Table Panel Sawbench

Diameter of Saw	300mm	12 in
Height of saw above table	95mm	3 $\frac{3}{4}$ in
Diameter of saw arbor	25mm	1 in
Maximum section of cut	1560x95 mm	61 $\frac{1}{2}$ x3 $\frac{3}{4}$ in
	1600x25 mm	63x1 in
Speed of saw spindle	3200 rev/min	3200 rev/min
Horsepower of motor - 3 phase	3.7 kW	5 hp
Size of Table		
To right of saw (fixed)	860x610 mm	34x24 in
To left of saw (sliding)	1120x1230 mm	44x48 $\frac{1}{2}$ in
Maximum travel of table	1700 mm.	67 in
Front fixed table to saw:		
With maximum depth of cut	445 mm	17 $\frac{1}{2}$ in
With 1 in (25 mm) depth of cut	480 mm	19 in
Maximum distance saw to rip fence	660 mm	26 in
Maximum distance saw to stops on sliding table	3000 mm	120 in
Saw to rip fence with extension table to right of saw	1500 mm	60 in
Height of table	860 mm	34 in
Floor space	3890x3960 mm	153x156 in
Net weight, approx	1016 kg	2240 lb
Gross weight, approx	1270 kg	2800 lb
Shipping dimensions	4 m	142 ft

**For Replacement Parts, Tools & Accessories,
Contact Brian Stacey,
Bursgreen (Durham) Ltd.,
Fence Houses, Houghton-le-Spring,
Tyne~Wear DH4 5RQ, England.
Telephone: Fence Houses 2385 (7 Lines)
Telex: 53441 (Bursgreen Durham)**

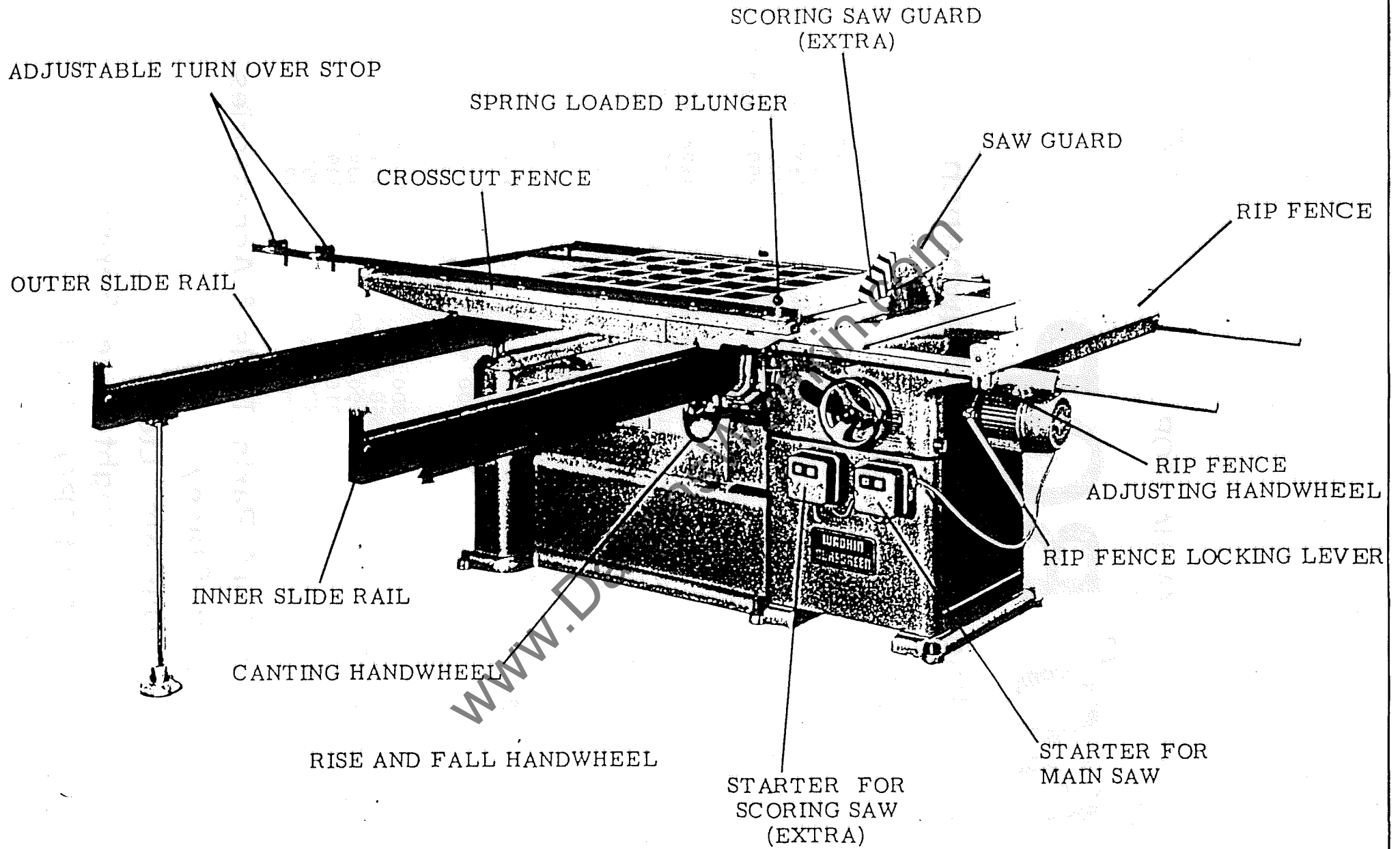

FIG 1



HEALTH & SAFETY

SAFETY OF WOODWORKING MACHINES

Woodworking machines can be dangerous if improperly used. The wide range of work of which they are capable, requires adequate safeguarding arrangements against possible hazards.

Many injuries to machinists are caused by carelessness or failure to use the guards provided or to adjust them correctly.

WADKIN LTD., supply machinery designed for maximum safety which they believe, as a result of thorough testing, minimizes the risks inevitable in their use. It is the user's responsibility to see that the following rules are complied with to ensure safety at work:

1. The operation of the machine should conform to the requirements of the Woodworking Machines Regulations 1974. All guards should be used and adjusted correctly.
2. Safe methods of working only should be adopted as given in the Health and Safety Work Booklet No.41, "Safety in the Use of Woodworking Machines", (obtainable from Her Majesty's Stationery Office) and as advised by Wadkin Ltd.
3. Only personnel trained in the safe use of a machine should operate it.
4. Before making adjustments or clearing chips, etc., the machine should be stopped and all movement should have ceased.
5. All tools and cutters must be securely fixed and the speed selected must be appropriate for the tooling.

SAFETY IS OUR WATCHWORD BUT THE USER MUST COMPLY WITH THE ABOVE RULES IN HIS OWN INTEREST. WE WOULD BE PLEASED TO ADVISE ON THE SAFE USE OF OUR PRODUCTS.

oOo

SAFETY

1. Read Instruction Book.
2. Securely Lock Cutters.
3. Set Guards Correctly.
4. Select Correct Speed.
5. Use Feeding Devices Where Possible.
6. Refer To HSW Booklet No.41. (in UK) For Safety In The Use Of Woodworking Machinery.

INSTALLATION

Remove protective coating from all bright parts by applying a cloth soaked in paraffin, turpentine or other solvent.

When the machine is cased for export the sliding table, slide bars, rip fence bars, and rip fence are removed and packed individually. Remove and re-assemble as shown in FIG 1.

WIRING DETAILS

The motor and control gear have been wired in before despatch. All that is required is to connect the power supply to the starter or isolator when fitted.

Points to note when connecting to power supply:-

1. Check that the voltage, phase and frequency correspond to those on the motorplate, also the correct coils and heaters are fitted to the starter.
2. It is important that the correct size of cable is used to give the correct voltage at the starter. Too light a cable will give a voltage drop at the starter and may damage the motor.
3. Check the main line fuses are of the correct capacity. See list below.
4. Correct the line heads to the appropriate terminals. See FIG 2 for 3 phase supply; FIG 3 for 1 phase supply or FIG 4 for 3 phase supply with scoring saw (extra)
5. Check all connections are sound.
6. Check the rotation of the motor for the correct direction. If this is incorrect, reverse any two of the line lead connections for 3 phase supply.

VOLTAGE	PHASE	KW MAIN MOTOR	KW SCORING MOTOR (EXTRA)	SWG TINNED COPPER WIRE	AMPS
220	3	2.2	0.55	21	29
380/420	3	2.2	0.55	24	17
550	3	2.2 & 3.7	0.55	24	17
220	3	3.7	0.55	19	38
380/420	3	3.7	0.55	22	24
200/220	1	2.2	0.55	17	65
230/250	1	2.2	0.55	18	45

LUBRICATION

It is advisable to keep all bright parts covered with a thin film of oil to prevent rusting.

See FIG 5 for Lubrication Instructions and FIG 6 for Approved Lubricants

Wiring Diagram For 3 Phase Supply (without scoring saw)

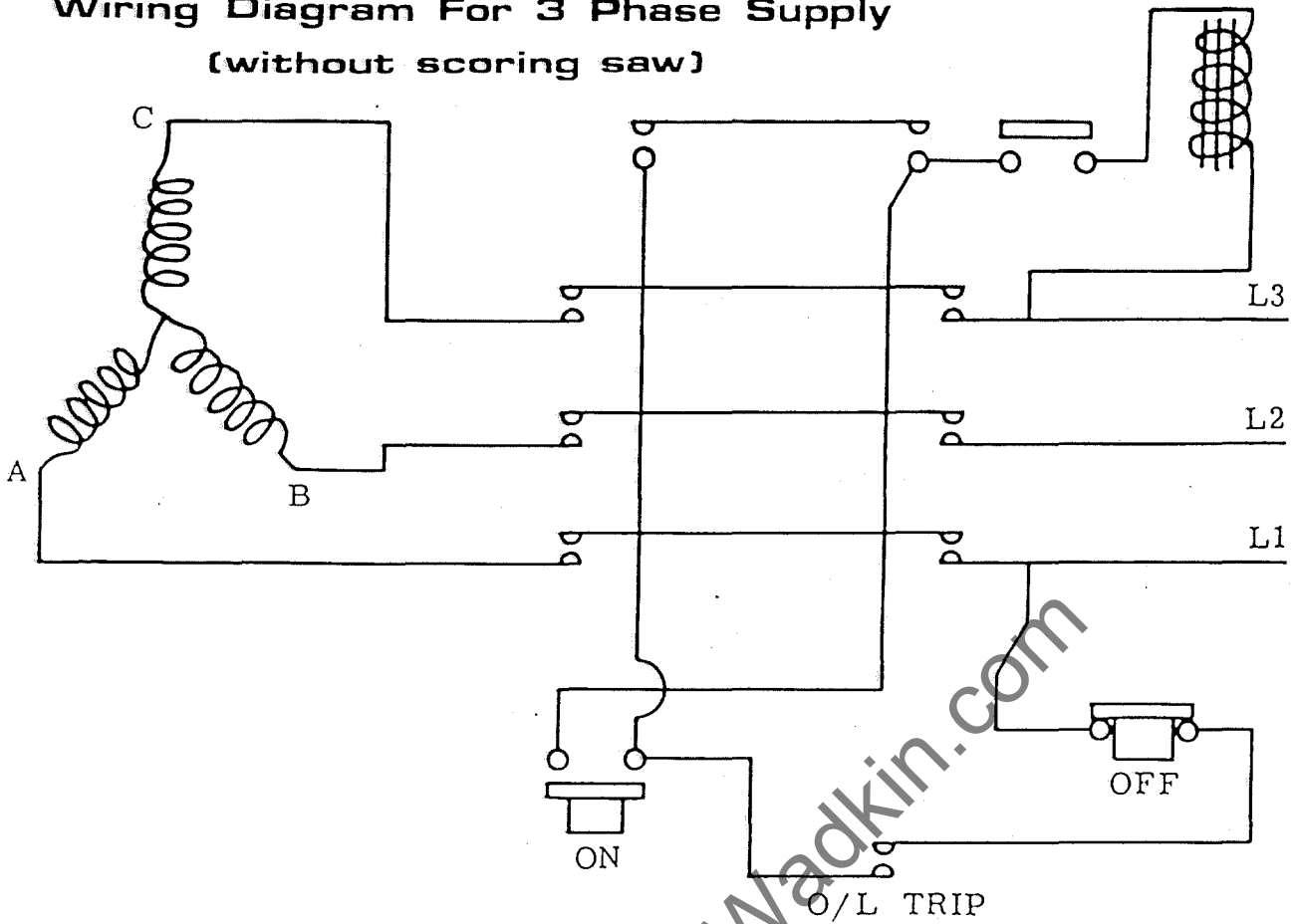

FIG 2

Wiring Diagram For 1 Phase Supply (without scoring saw)

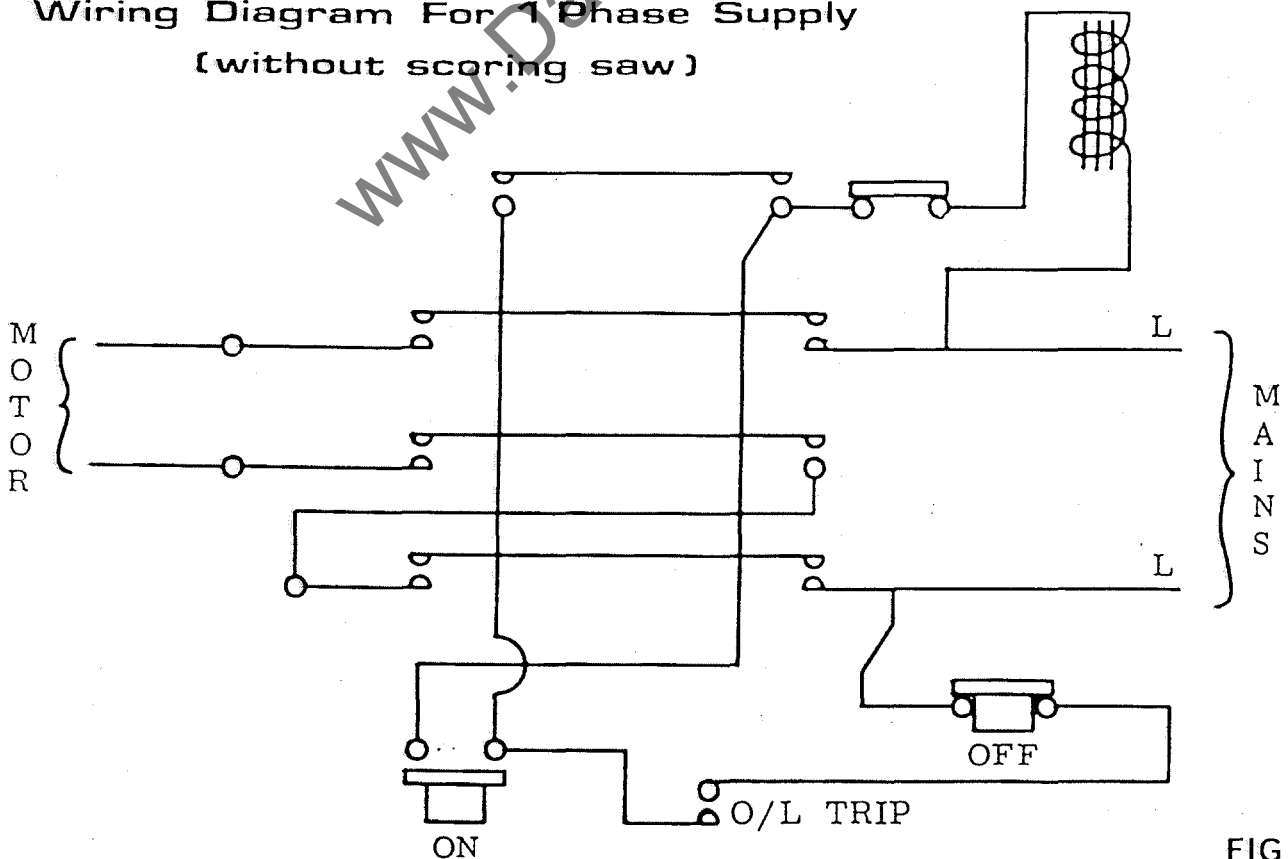

FIG 3

Application	Approved Lubricant						
	Castrol	B. P.	Shell	Esso	Texaco/ Caltex	Gulf	Wadkin
Worm Boxes	Alpha 617	Energol CS 425	Vitrea 75	Pen-O-Led E. P. 3	Regal Oil J	EP Lubricant S104	L. 2.
General Lubrication	Magna ED	Energol HP. 20	Vitrea 33	Esstic 50	Ursa Oil P. 20	Security 53	L. 4.
Pneumatic Lubricators	Hyspin AWS 32	Energol HL 65	Tellus 27	Nuto H44	Rando Oil HDA	Harmony 43 AW	L. 1.
Grease	Spheerol AP. 3	Energrease LS. 2	Alvania 2	Beacon 2 Starfak Premium 2	Regal	Gulf Crown Grease No. 2	L. 6.
Brake Cables	Brake cable grease	Energrease L21M	Alvania 3	Multi- purpose grease H		Gulf crown Grease EP No. 2	

FIG 6

FOUNDATION

See FIG 7 for bolt positions and clearances required. When installing the machine the levelling instructions in the following section should be carefully followed.

Foundation bolts are not supplied with the machine except by special order.

LEVELLING INSTRUCTIONS

WE RECOMMEND THAT THIS MACHINE BE SECURELY BOLTED TO THE FLOOR AND LEVELLED TO ENSURE ACCURATE AND SAFE OPERATION

1. Place a precision spirit level on the sliding table in positions "A" and "B", in FIG 7, adjust the adjusting screws "C" until the table is level both ways
2. Move the rip fence to the extreme right hand position and with the sliding table in line with the fixed table, place a straight edge across both tables in positions "D" and "E". The sliding table should be parallel and .005 to .010" (.15mm to .3mm) above the fixed table. If tables are incorrect, adjust the screws "C" until the tables are correctly aligned, if adjustment is necessary, re-check the level of the sliding table at positions "A" and "B".
3. With the straight edge in position "D", check the sliding table is parallel to the fixed table throughout its travel.
4. After bolting the machine in positions check the above mentioned procedure to ensure the machine is still correctly aligned.

MOUNTING SAW BLADES

To mount a sawblade, the undermentioned procedure should be followed:-

1. Check the machine is isolated electrically before starting to fit sawblade.
2. Swing the sawguard to the top position.
3. Raise saw arbor to its highest position then move sliding table to its maximum forward position to gain access to the saw arbor.
4. Remove the arbor nut (left hand thread) and front saw flange.
5. Select the blade which is required depending on the type of work which is to be done. Check the blade is free from all dirt, gum or sawdust especially where it will be gripped by the flanges. Mount the blade on the arbor. Check the front saw flange is clean and then fit on to saw arbor. The saw teeth should point towards the front of the machine.

NOTE:- If the flanges and the saw are not clean, the saw will run out of true, hence causing vibration.

6. Lock the saw securely in position with the arbor nut (left hand thread). To tighten arbor nut hold spindle in position with the toggle bar in the back saw flange.
7. Position the saw guard depending on the thickness of timber to be worked. Clearance between sawguard and timber should be as small as is practicable and at no time should it be possible for the fingers to pass between guard and timber.

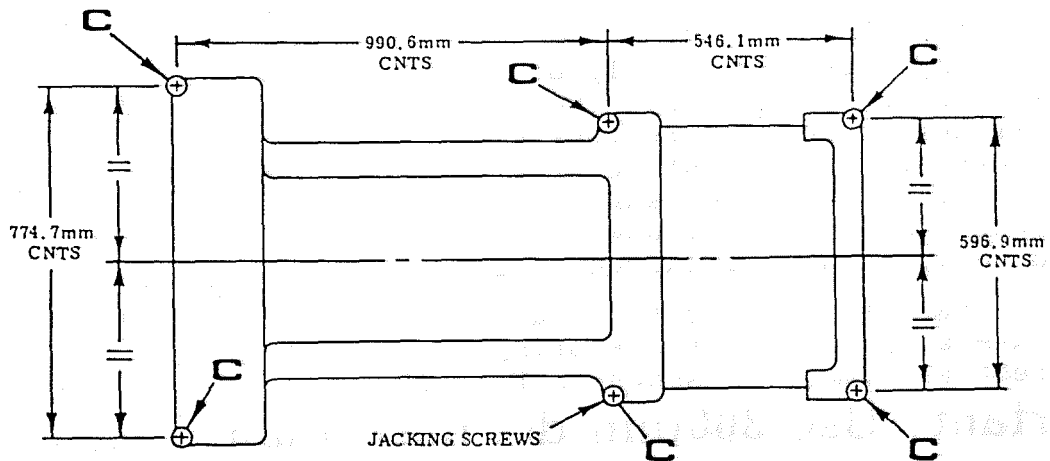
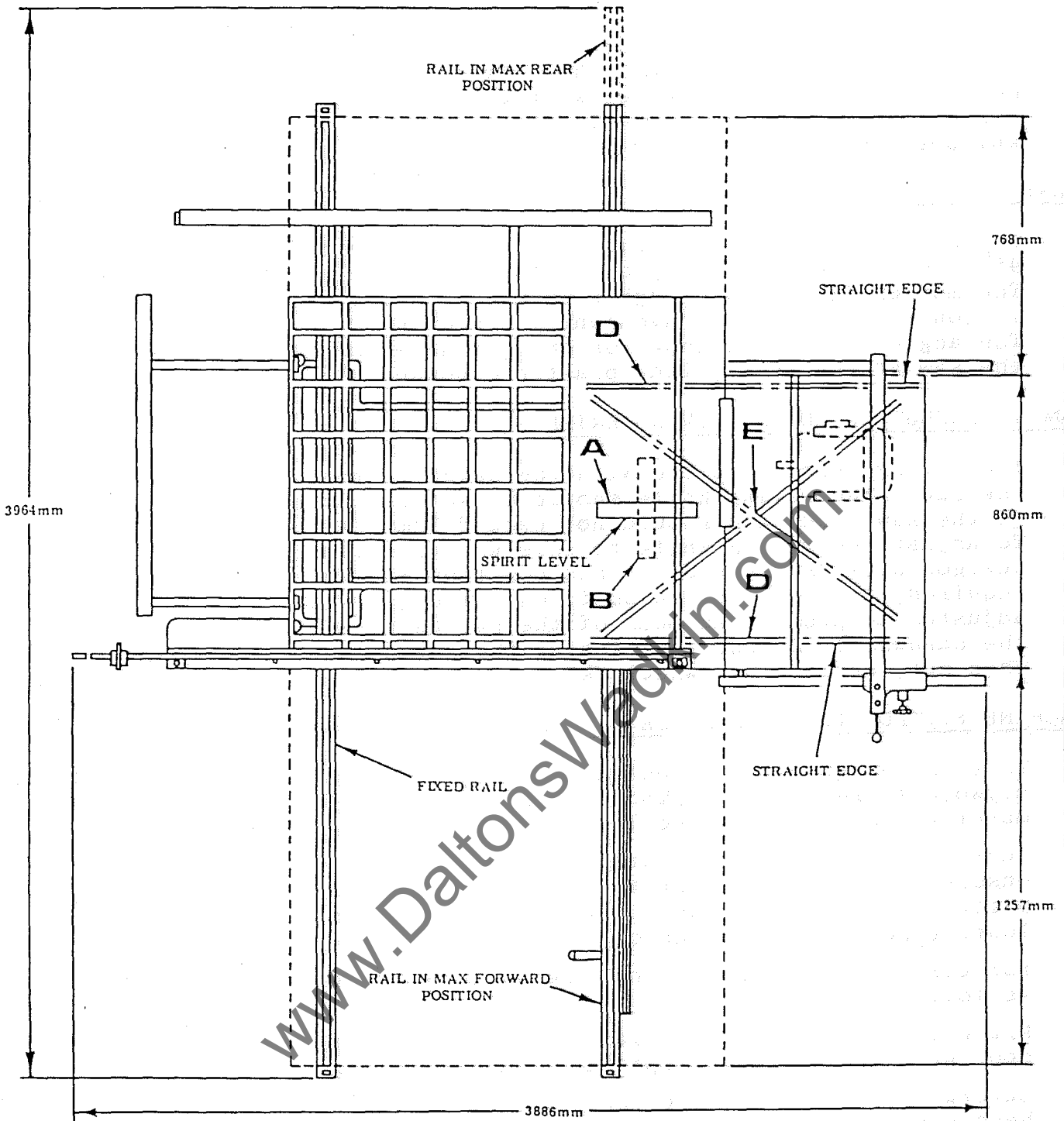

FIG 7

RISE AND FALL CONTROLS.

The saw arbor rises and falls by wormwheel and quadrant and has a total travel of 3 $\frac{3}{4}$ " (95mm). The travel of the saw is pre-set before despatch from the works, and is controlled by the conveniently placed handwheel "A" in Fig. 8. To lock the saw in any position, lock plastic handwheel "B".

CANTING CONTROLS.

The saw cants 45° to the right, with positive stops at 90° and 45°, which are accurately set before despatch from the works. The motion is again through a wormwheel and racked quadrant and is controlled by the conveniently placed handwheel "C" in Fig. 8. The angle of cant is shown on the graduated scale "D". To lock the saw at any angle, lock plastic handwheel "E".

HOW TO ADJUST GUARD AND RIVING KNIFE.

The riving knife complete with the sawguard rises and falls with the saw. The riving knife should be set as close as practicable to the saw blade and should not exceed 12mm at the table level. To adjust the riving knife to this position loosen the 2 - hexagon nuts "A" in Fig. 7, and position riving knife where required, then re-lock in position. The guard should then be adjusted to protect as much of the saw as possible by loosening the handwheel "B" and positioning the guard where required. When set, re-lock handwheel "B".

MACHINE FITTED WITH SCORING SAW (EXTRA).

This is designed to prevent splitching of all materials including plywood, fibreboard, chipboard, thicker solid plastics and materials having two face layers of veneer, etc.

Scoring saw lateral and vertical adjustments are provided to ensure accurate alignment to thickness of main saw blade so that brittle materials can be cut with perfect finish on upper and lower edges at both sides of cut.

For correct alignment of the scoring blade to main blade, proceed as follows:

1. Place a steel rule or similar straight edge across main blade and scoring blade to check approximate lateral alignment.
2. Lateral adjustment to scoring blade is by releasing 8mm socket head capscrew lock "A" in Fig. 10, (8mm allen key supplied) then adjust blade laterally by 8mm socket head capscrew "B". When set correctly, re-lock socket head capscrew "A".
3. Adjust scoring blade vertically by loosening 8mm socket head capscrew lock "A" in Fig. 10, then move blade vertically by lever "C". When set correctly, re-lock socket head capscrew "A". Correct vertical adjustment is attained when the scoring saw scores the full underside length of panel.

NOTE: Some panels may be badly bowed in which case the scoring saw should be vertically adjusted to suit.

4. Proceed to take trial cuts to establish the accuracy of your approximate alignment of the scoring blade with main blade. The correct alignment is shown in Fig. 12.

Important; Use 300mm dia max' main sawblade when scoring, 12" dia blade is too large and would foul scoring saw.

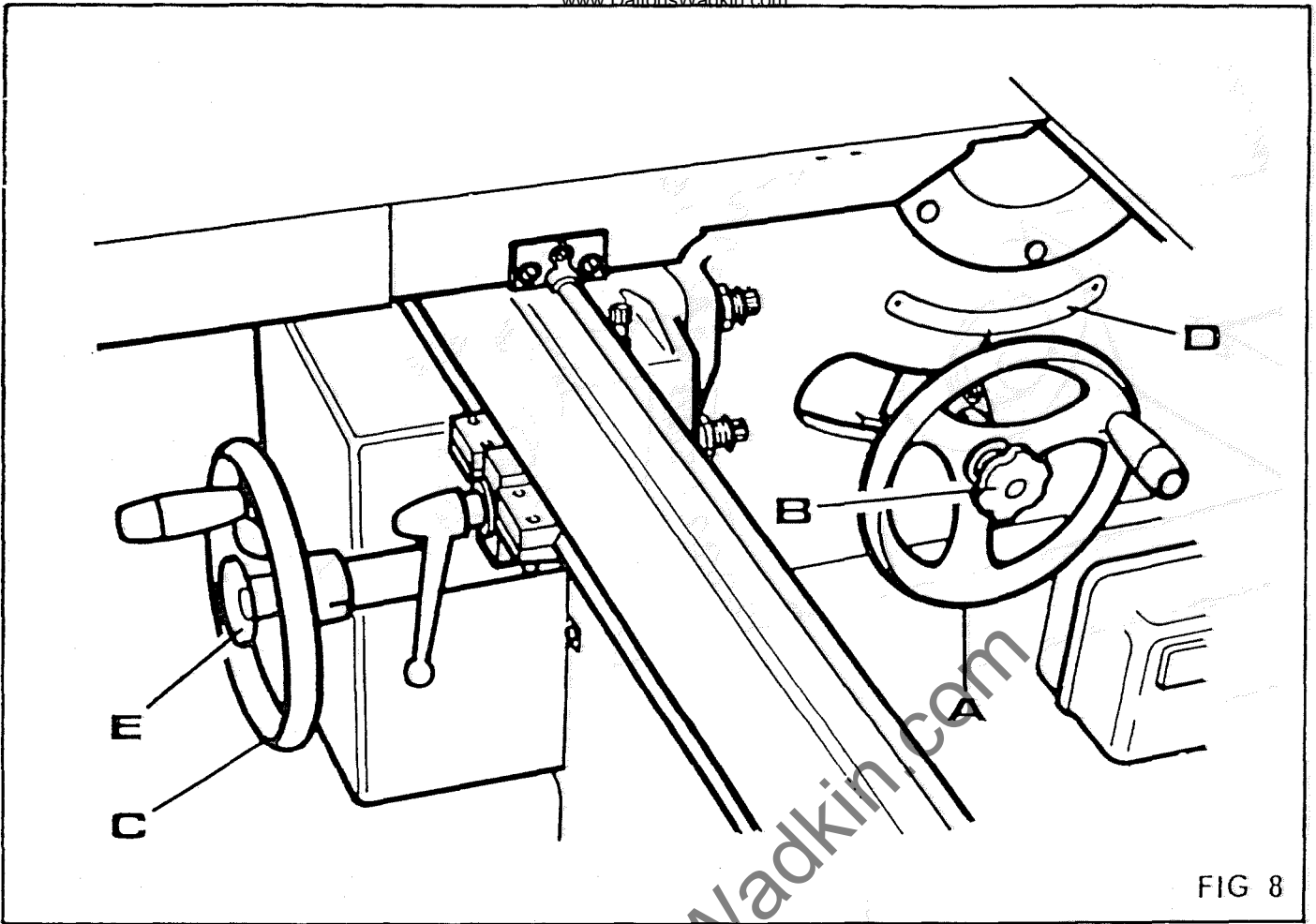

FIG 8

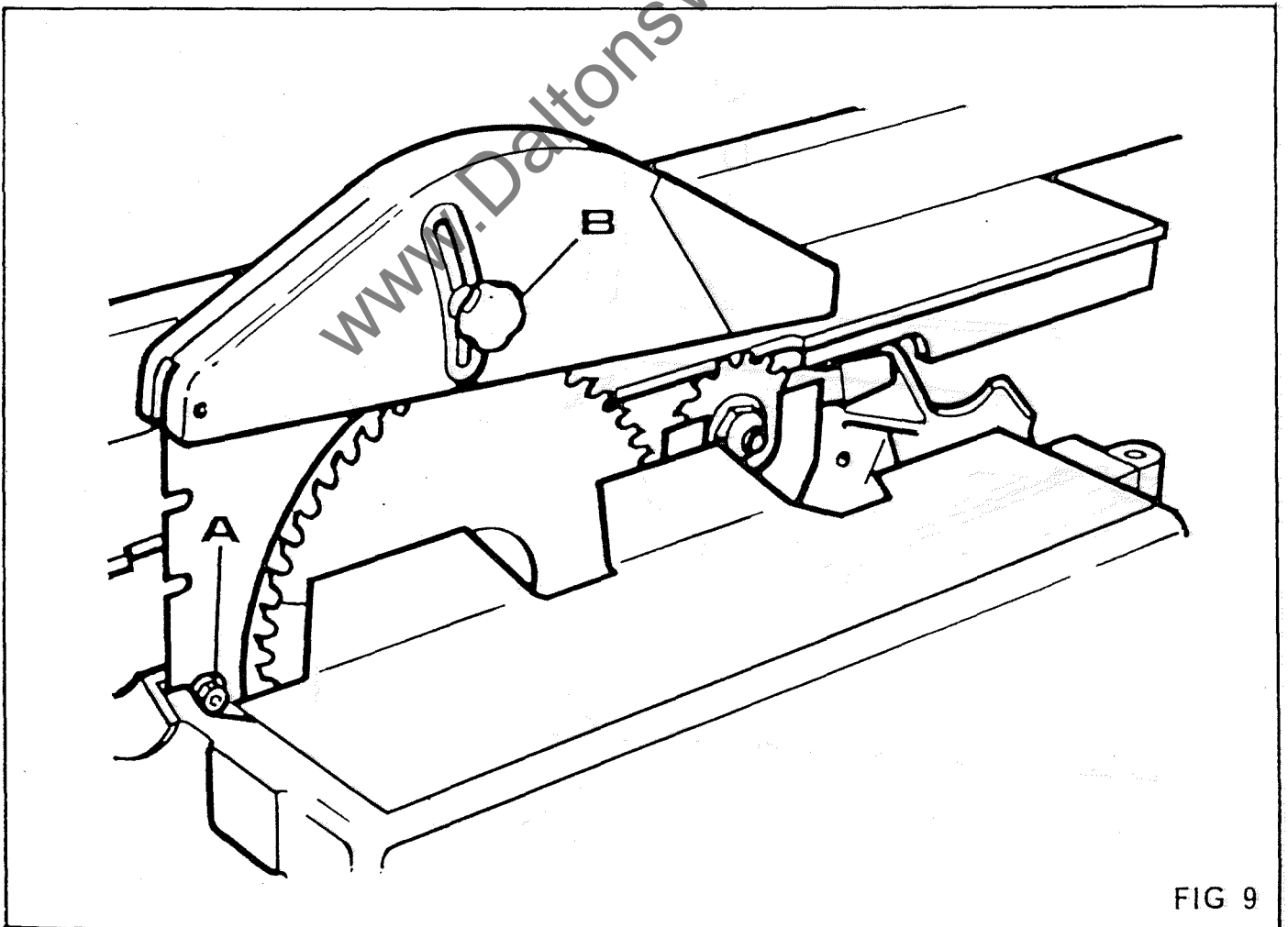

FIG 9

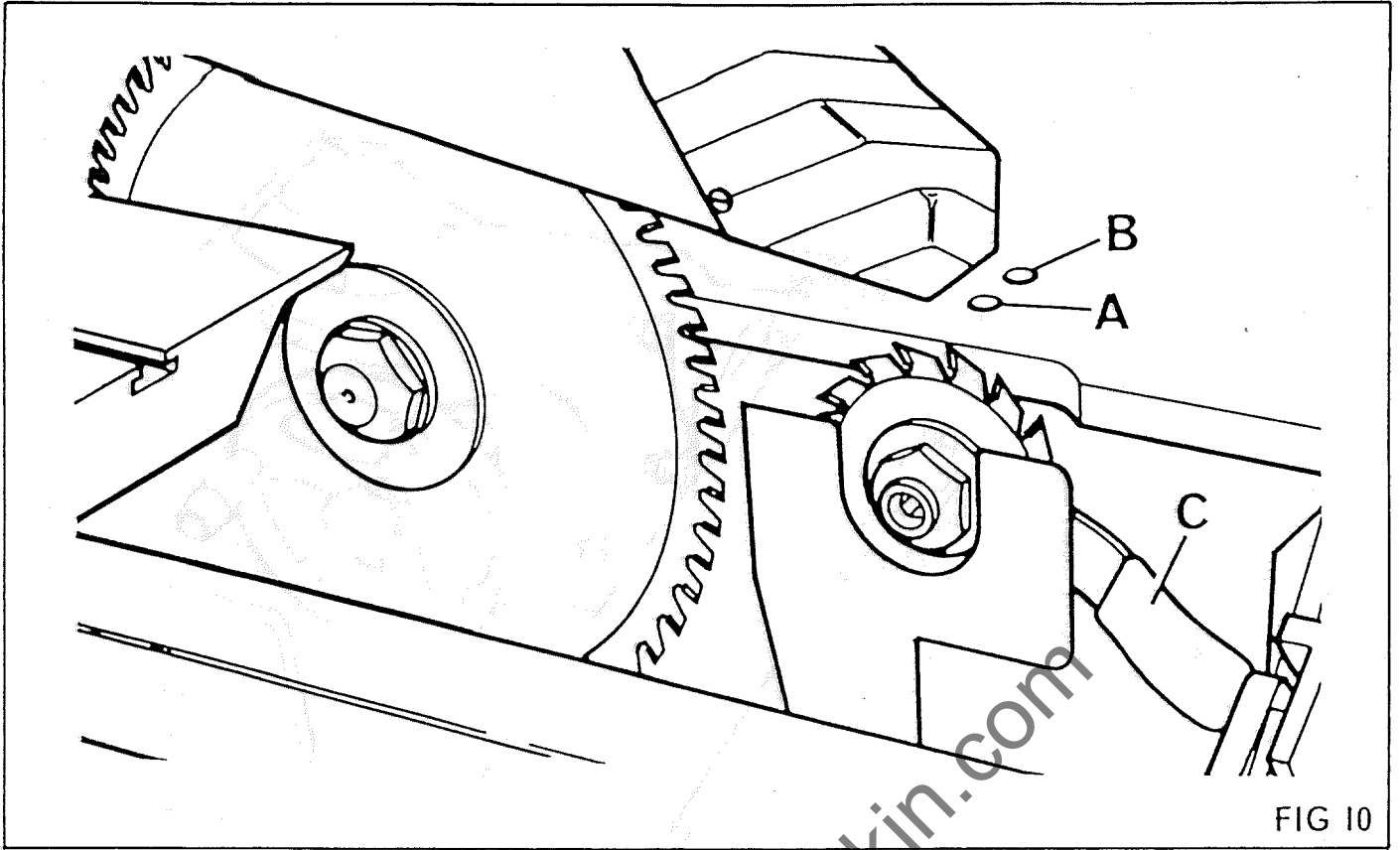

FIG 10

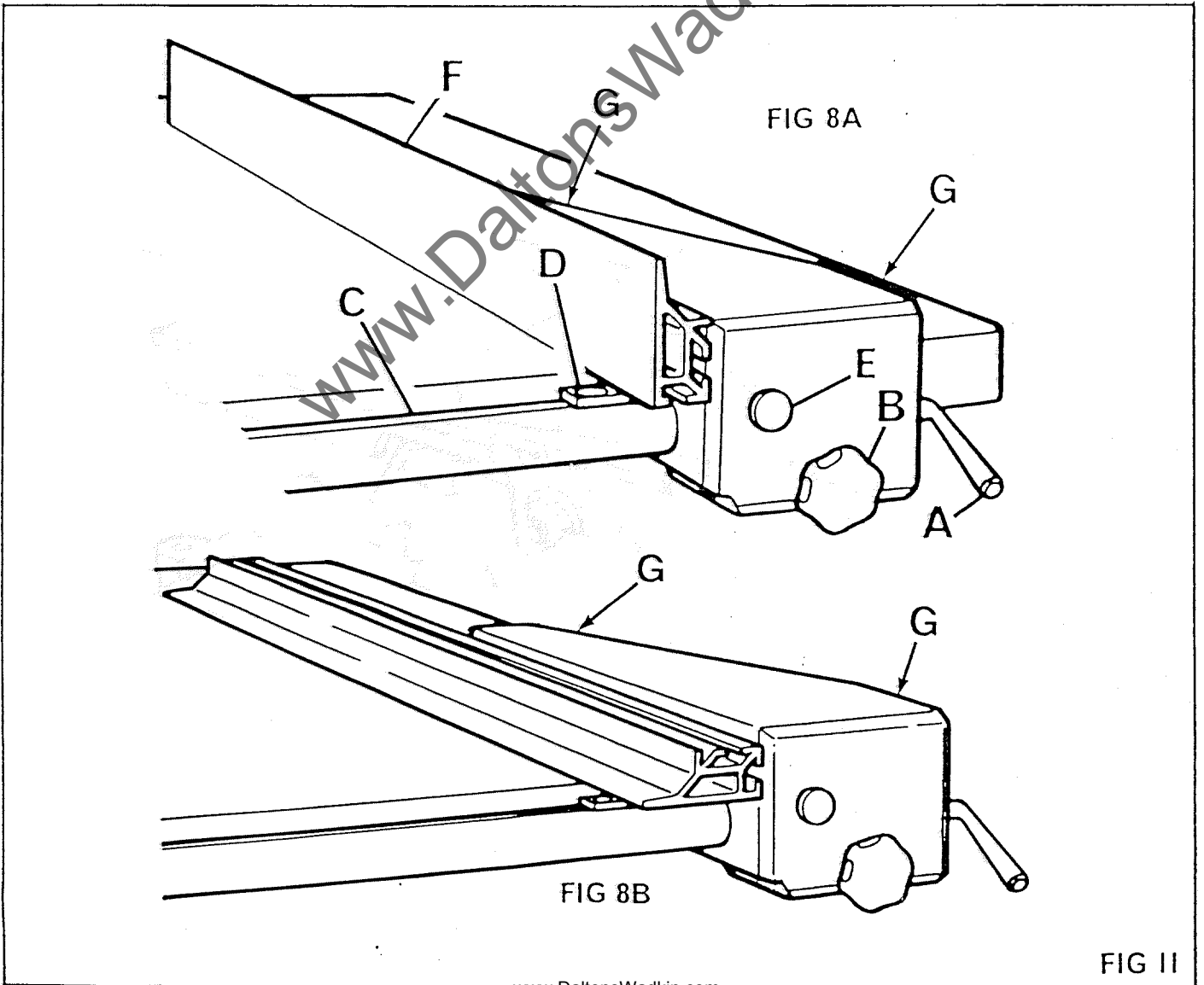

FIG 8A

FIG 8B

FIG 11

RIP FENCE CONTROLS.

The rip fence slides on a round bar fitted to front of table. Rapid fence adjustment and micro adjustment are provided with an effective lock.

For rapid fence adjustment follow the undermentioned procedure:

1. Lift handle "A" in Fig. 11A then disengage the pinion from front racked fence bar by pulling handwheel "B" out of fence front bracket.
2. Position fence where required then depress handle "A" to lock fence in position. A ripping capacity scale on fence slide bar "C" is indicated by an adjustable pointer "D" located in the fence body and secured by knurled knob "E".
3. For micro adjustment the pinion should be engaged in the racked fence slide bar, i.e. handwheel "B" pushed into the fence front bracket.

Fence Plate Positions.

The fence plate "F" in Fig. 11 has 2 positions. Position shown in Fig. 11A is for use with deep stock. Position shown in Fig. 11B is for use with faced panels, melamine, veneer, etc.

To Change the Fence Plate Position, Proceed As Follows:

1. Loosen knurled knobs "G" in fig 11A, then slide fence plate "F" from fence body.
2. Slide fence plate over the 2 locking plates to position shown in Fig. 11B, re-lock knurled knobs "G".

Fence Pointer Adjustment.

When the fence plate position had been changed as previously described, the pointer "D" in Fig. 11A must be re-set accordingly.

To Re-Set Pointer, Proceed As Follows:

1. Lift handle "A" in Fig. 11A, then move fence to a position which would allow a reasonable cut to be taken. Depress handle "A" to lock fence in position.
2. Start machine, then feed a piece of timber past the sawblade keeping timber firmly against the fence. Stop machine.
3. Accurately measure the width of timber after cut then loosen knurled screw "E" and set rule pointer "D" accordingly. Re-lock knurled screw "E".

ALIGNMENT OF SCORING SAW WITH MAIN SAW**END VIEW OF SAWBLADES**

adjust scoring saw
laterally until in line
with main saw
as shown.

main saw width at teeth.

table top.

adjust scoring saw
vertically until
speltching is
eliminated.

scoring saw.



FIG 12

Wiring Diagram For 3 Phase Supply (with scoring saw)

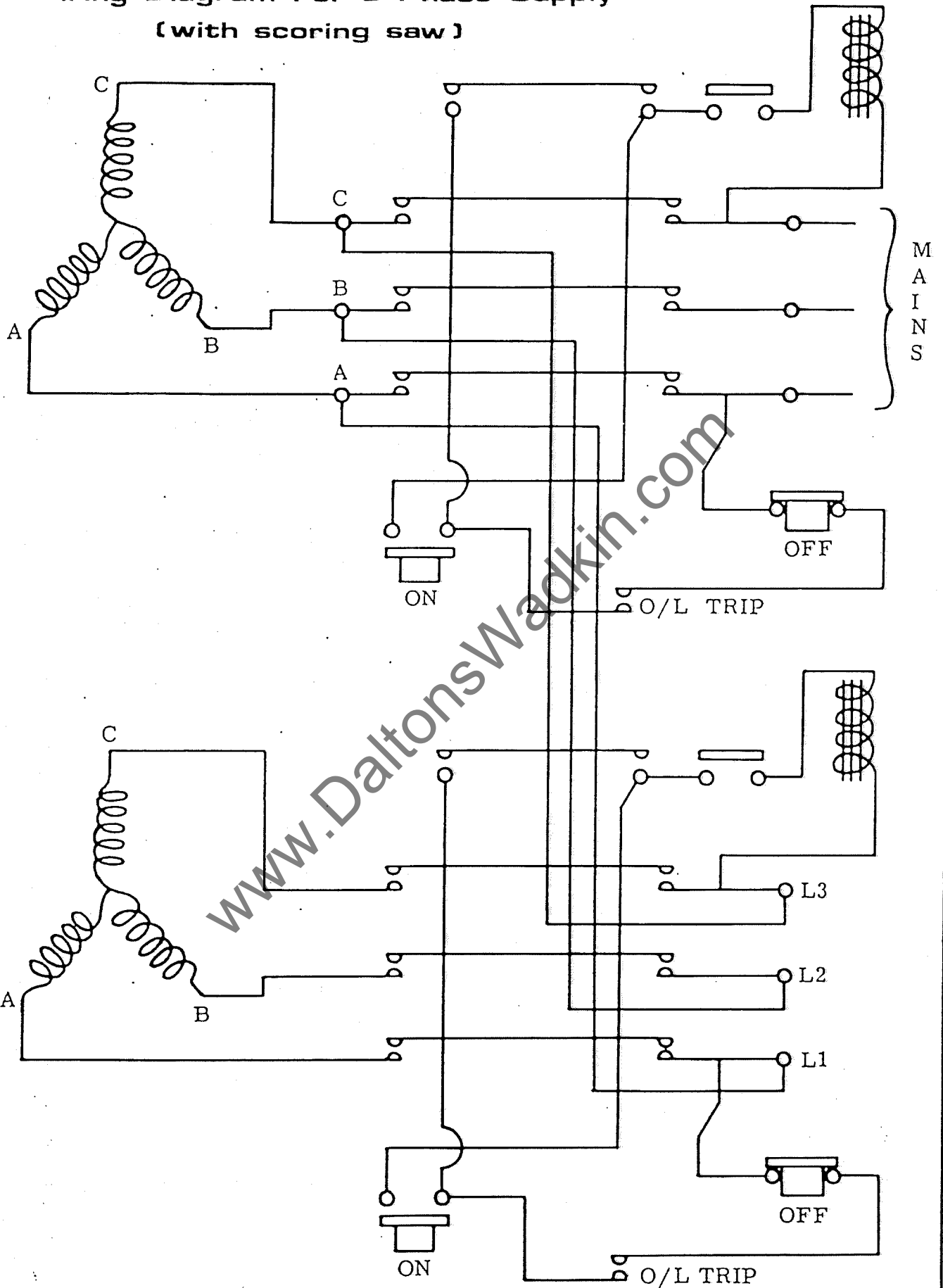
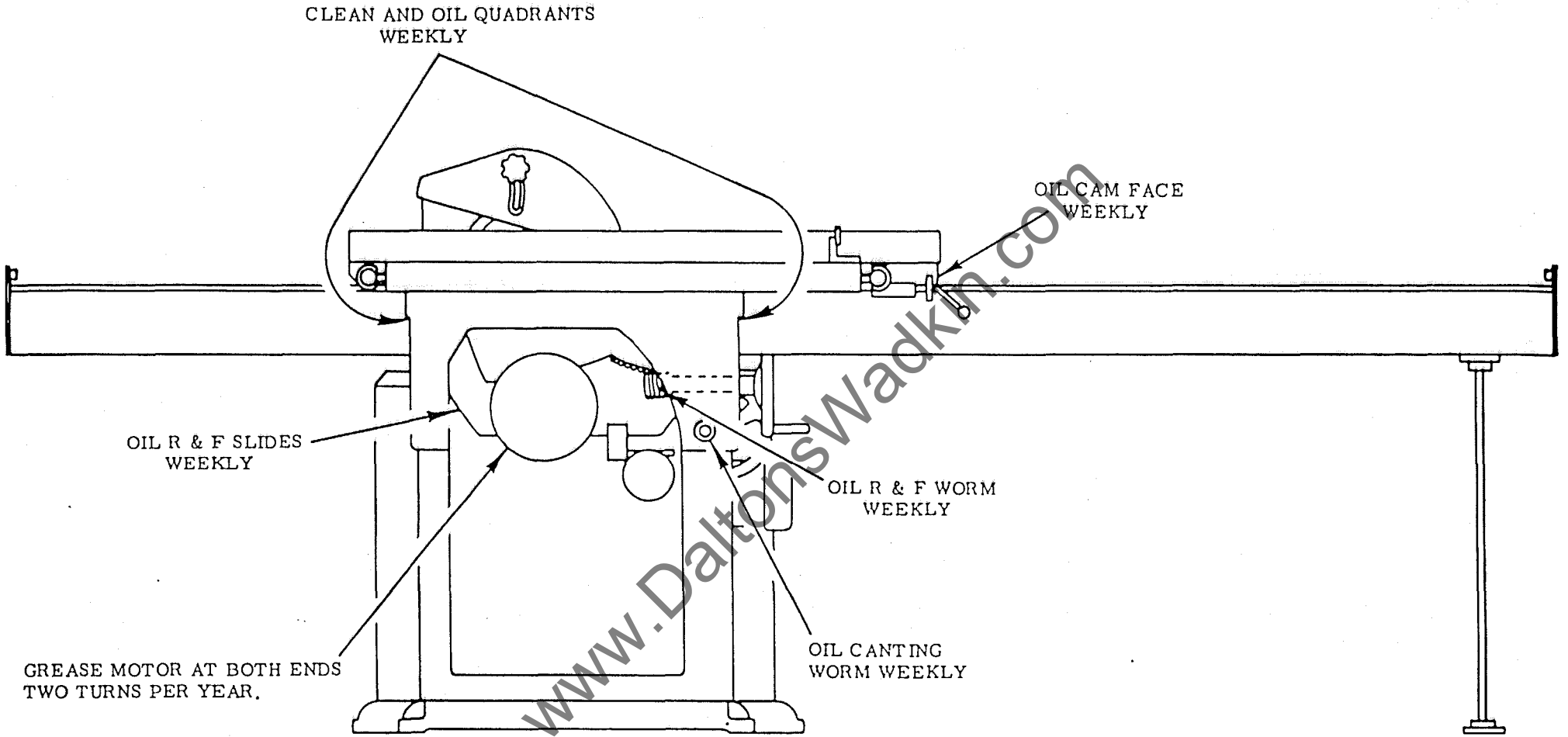

FIG 4



LUBRICATION INSTRUCTIONS

FIG 5

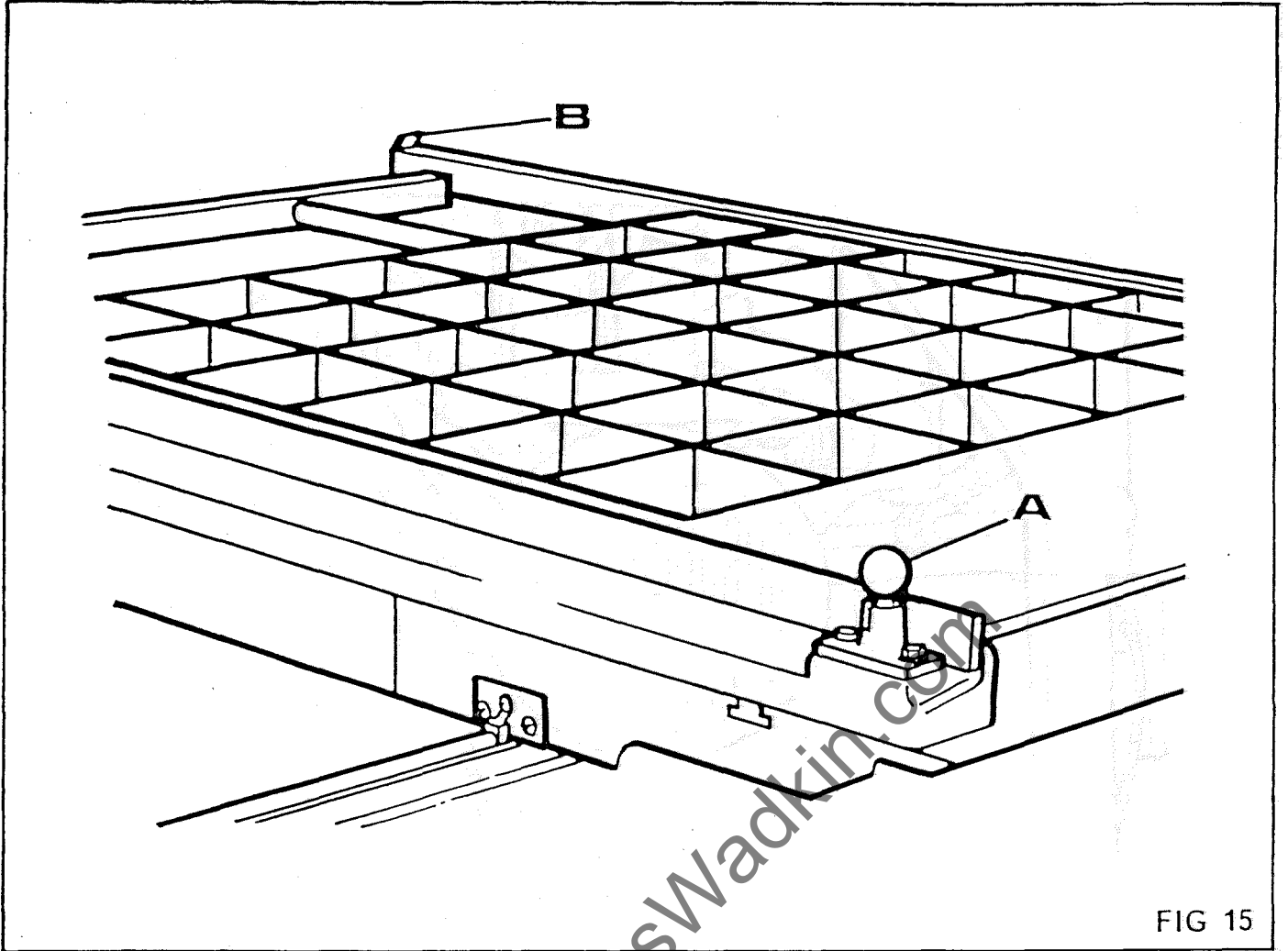

FIG 15

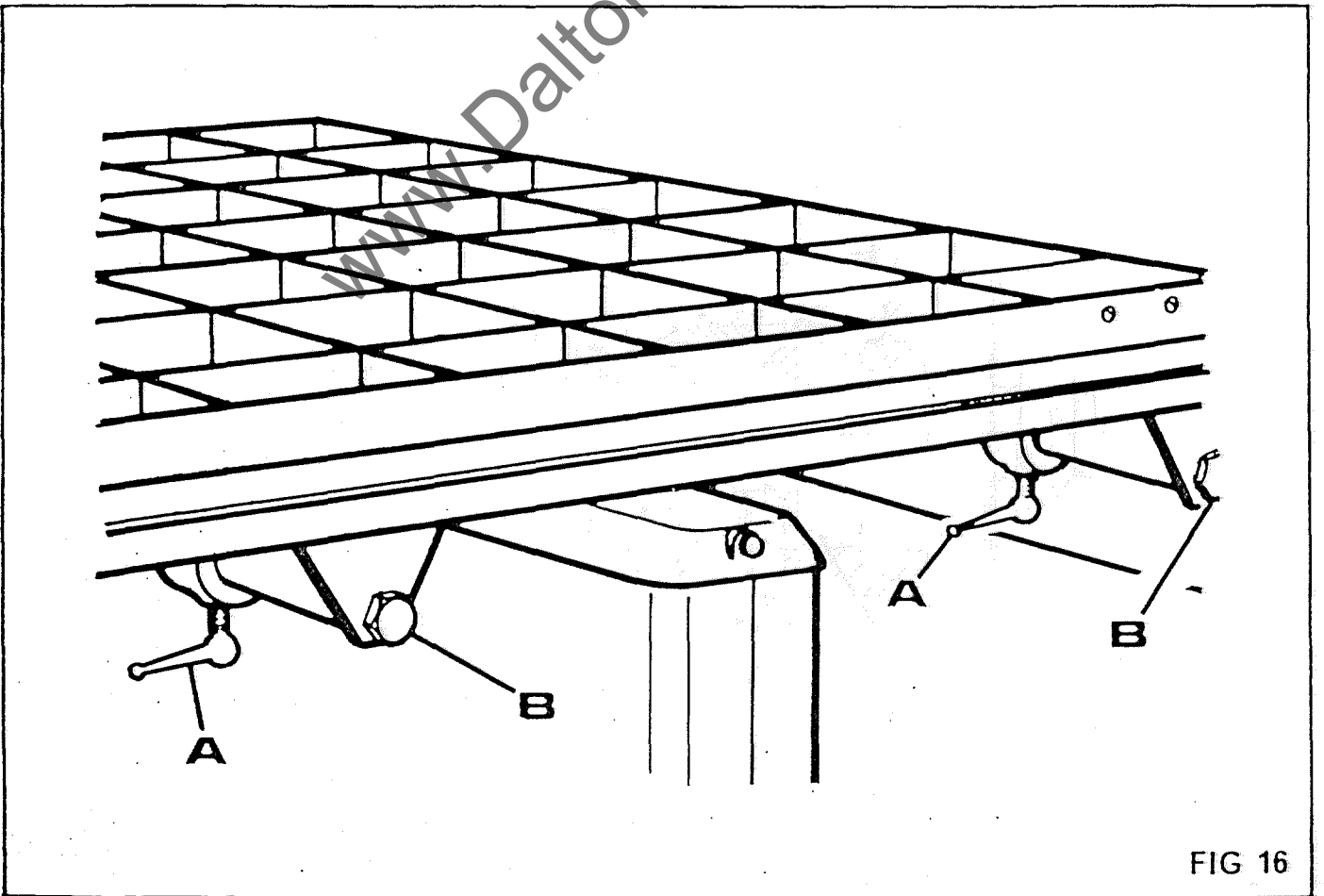

FIG 16

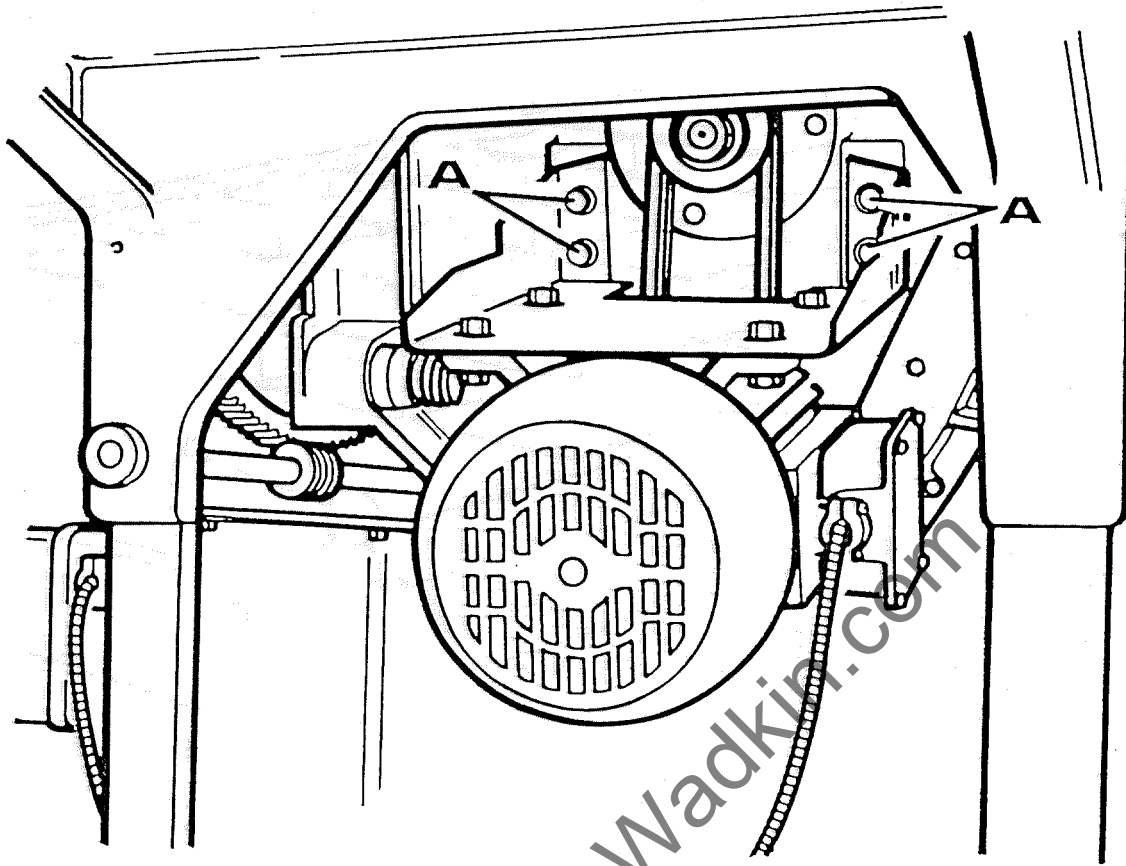

FIG 17

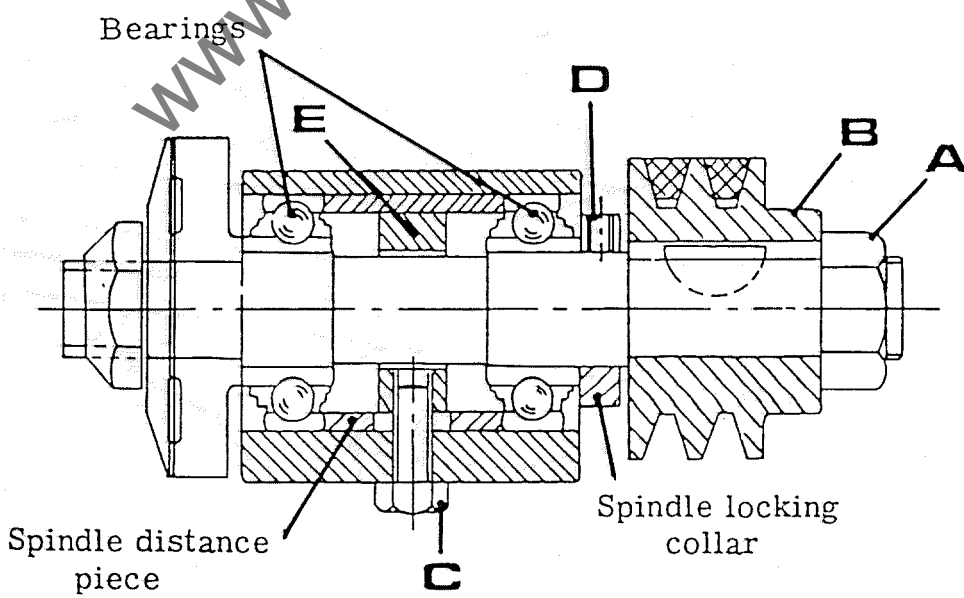

FIG 18

SLIDING TABLE LOCK.

To convert machine into a standard sawbench the sliding table can be secured in line with main table.

To secure sliding table, proceed as follows:

1. Position sliding table in line with main table.
2. Loosen knurled screw "A", FIG. 13, then locate locking arm "B" between location bosses "C", as shown.
3. Tighten knurled screw "A".

NOTE: When locking arm "B" is not in use, it should be swung around 270° and secured clear of outer rail "D" and table top by knurled screw "A".

HOW TO REMOVE INNER SLIDE RAIL

The inner slide rail can be moved towards the rear when the machine is required to be used as a standard sawbench or to reduce the maximum movement of the table to the front of the saw. To slide inner rail, loosen the two ball lever screws "A" in FIG 14, move the rail until the required position is reached then re-lock screws "A".

CROSSCUT FENCE

The crosscut fence is positioned square to the saw and is held by a pivot pin at one end and a spring loaded plunger at the other. To use the machine as a standard sawbench, the crosscut fence can be swung clear of the table. This can be done by lifting the spring loaded plunger "A" in FIG 15 from the locating hole and turning the plunger so that it cannot return to normal position. The fence can then be swung round till it reaches the fence stop "B". The machine can now be used as a standard sawbench. To use the fence as a crosscut fence, reverse the above procedure. NOTE: - To accommodate for 8ft. capacity, remove stop bar & replace as shown in diagram :-

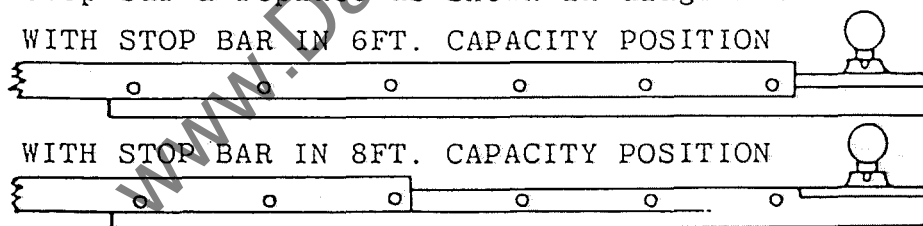
TO ADJUST TABLE EXTENSION TO REAR OF SLIDING TABLE

The support to the rear of the sliding table has a total movement of 12 $\frac{3}{4}$ " (324mm) increasing the table length to 46 $\frac{3}{4}$ " (1188mm)

To move support, loosen the two ball lever screws "A" in FIG 16 and position support where required and re-lock lever screws "A".

The support should be level with the table top; should it be disturbed, loosen hexagon head bolts "B" and set level to table top. When set, tighten all bolts.

BELT TENSION

The drive is by two vee belts from a 3HP motor. To tension the belts, loosen the hexagon head bolts "A". FIG17, move motor platform until the required tension is reached then re-lock hexagon head bolts "A".

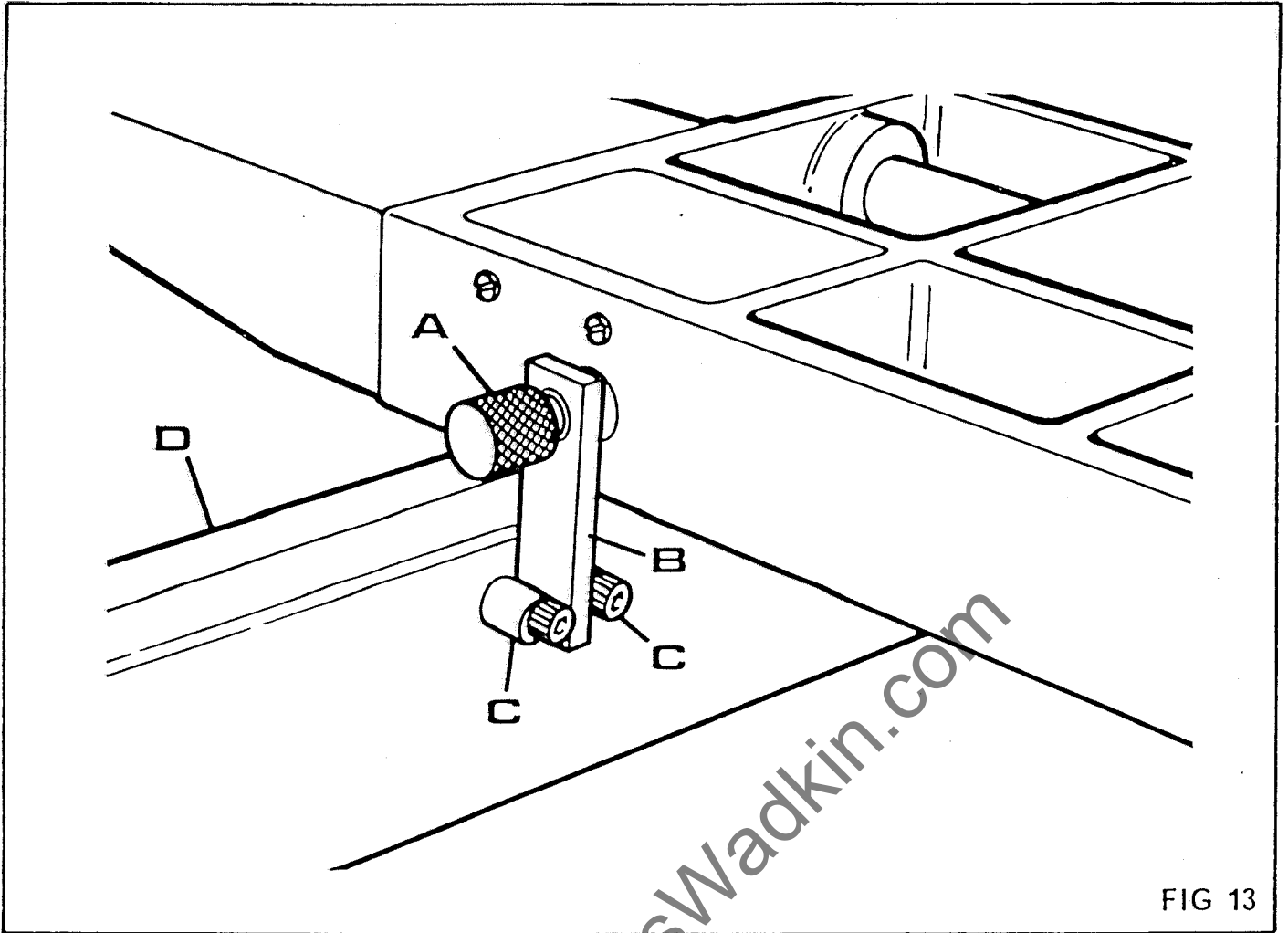

FIG 13

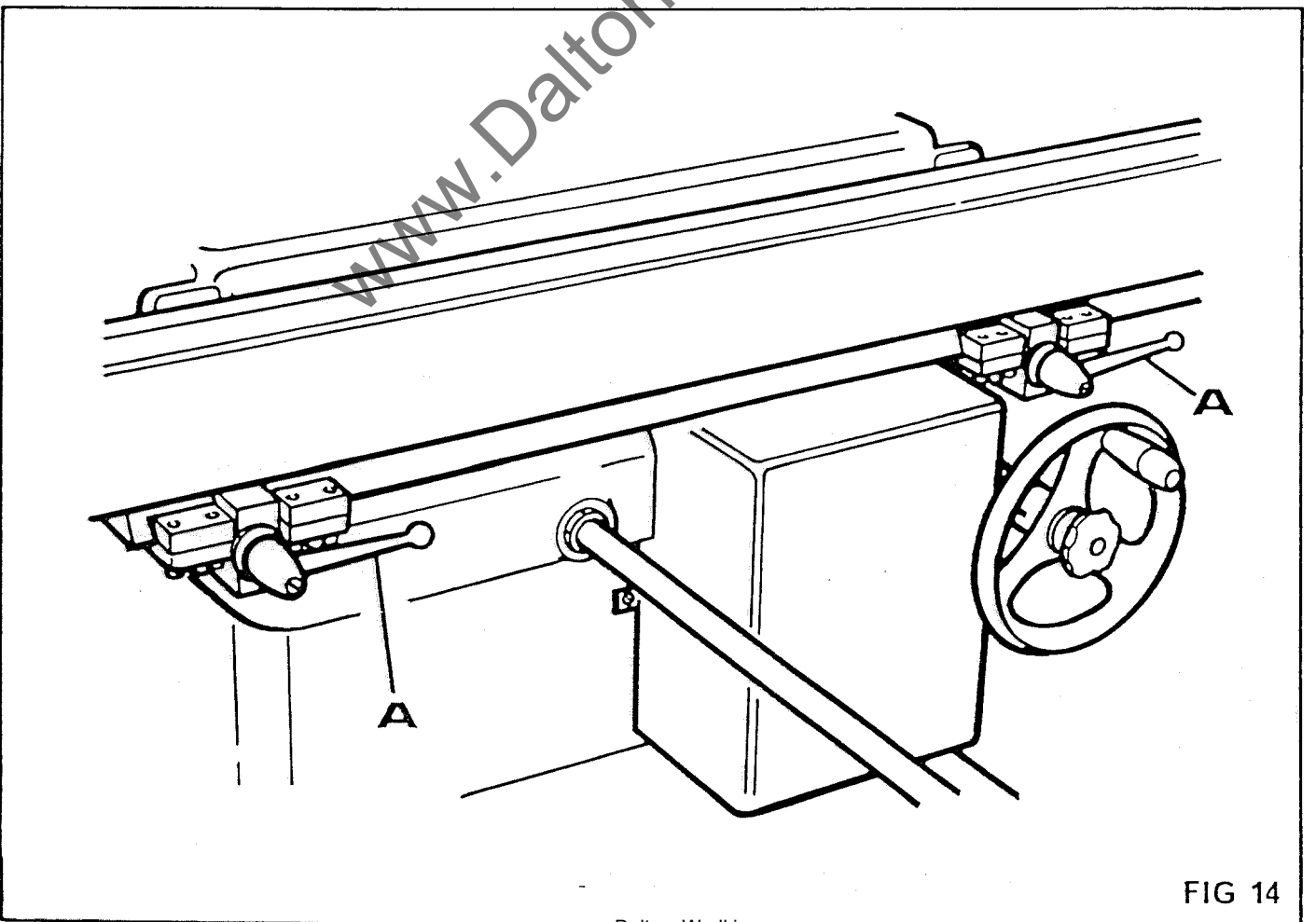

FIG 14

HOW TO REPLACE SPINDLE BEARINGS

To replace spindle bearings the undermentioned procedure should be followed:-

1. Remove saw, sawguard complete with riving knife and the fixed table.
2. Release the tension on the belts as previously described and remove belts.

Now working from motor end of the spindle.

3. Remove the 1" fine thread nut (right hand thread) "A" in FIG 18 remove spindle pulley "B", which is keyed to the spindle.
4. Remove the hexagon head bolt "C" securing the remaining spindle assembly in the housing, tap out assembly from pulley end. Care should be taken not to damage the threads on spindle end.
5. To Remove the bearings, remove the woodruff key then loosen the two M6 socket head grubscrews "D", remove the spindle locking collar.
6. The bearings and spindle distance piece can now be driven from the spindle.

The bearings should now be replaced as the arrangement in FIG 18 Care should be taken not to pre-load the bearings i. e. The spindle distance piece should be just free between the two bearings.

When the locking collar has been replaced and the assembly is ready to be replaced in the spindle housing, a socket head grubscrew should be inserted in the spindle trapping collar "E". This will assist in lining up the M10 x 30 long hexagon head bolt "C" on assembly.

To re-assemble the spindle assembly into the spindle housing:-

1. Line up socket head grubscrew with the hole in the spindle housing and tap in spindle assembly.
2. Remove socket head grubscrew and replace hexagon head bolt "C".
3. Replace riving knife and set saw central to riving knife as described in the following section.
4. Replace the pulley and belts then re-tension belts. The table can now be replaced.
5. Before locking table in position ensure table is level to the sliding table and the table lip is parallel to table lip of sliding table.

When set tighten all bolts.

SETTING SAW TO RIVING KNIFE.

It is most important that the saw and the riving knife are in line. To re-set after the spindle has been disturbed, the undermentioned procedure should be followed:

1. Loosen the hexagon head adjuster bolt "C", in Fig. 18 and tap spindle as required, taking care not to damage the threads on the spindle ends. Place a steel rule along both sides of riving knife to check whether the saw is central.
2. When set, re-tighten the hexagon head bolt "C".
3. To check this setting, feed a short piece of timber from the rear, along both sides of the riving knife. If the riving knife is correctly set, the blade will cut equal shoulders as shown in Fig. 19(a) and when incorrectly set, unequal shoulders as shown in Fig. 19(b).

ARRANGEMENT OF SHEET METAL EXTENSION TABLE (EXTRA).

A sheet metal extension table can be supplied to fit to the right of the saw as shown in Fig. 20. This table increases the capacity right of the saw to 50" (1270mm) between saw and rip fence.

To assemble table, proceed as follows:

1. Remove protective coating from extension table parts by applying a cloth soaked in paraffin, turpentine or other solvent.
2. Fit extra wing "A" in Fig 20 to end of main table.
3. Fit long fence bar "B" as shown in Fig. 20 ensuring bar is correctly positioned, i.e. Zero mark on graduated bar to centre of table.

NOTE: When fitting long bar, lift bar to uppermost position on socket head screws before fully tightening screws.

4. Assemble table "C" as shown in Fig. 20 ensuring that extension table top is level with main table top.

NOTE: Level extension table by loosening the 4 - adjuster plates "D" and/or 2 - feet "E", level table correctly using spirit level then relock adjuster plates "D" and/or feet "E".

CORRECT

INCORRECT



FIG 19

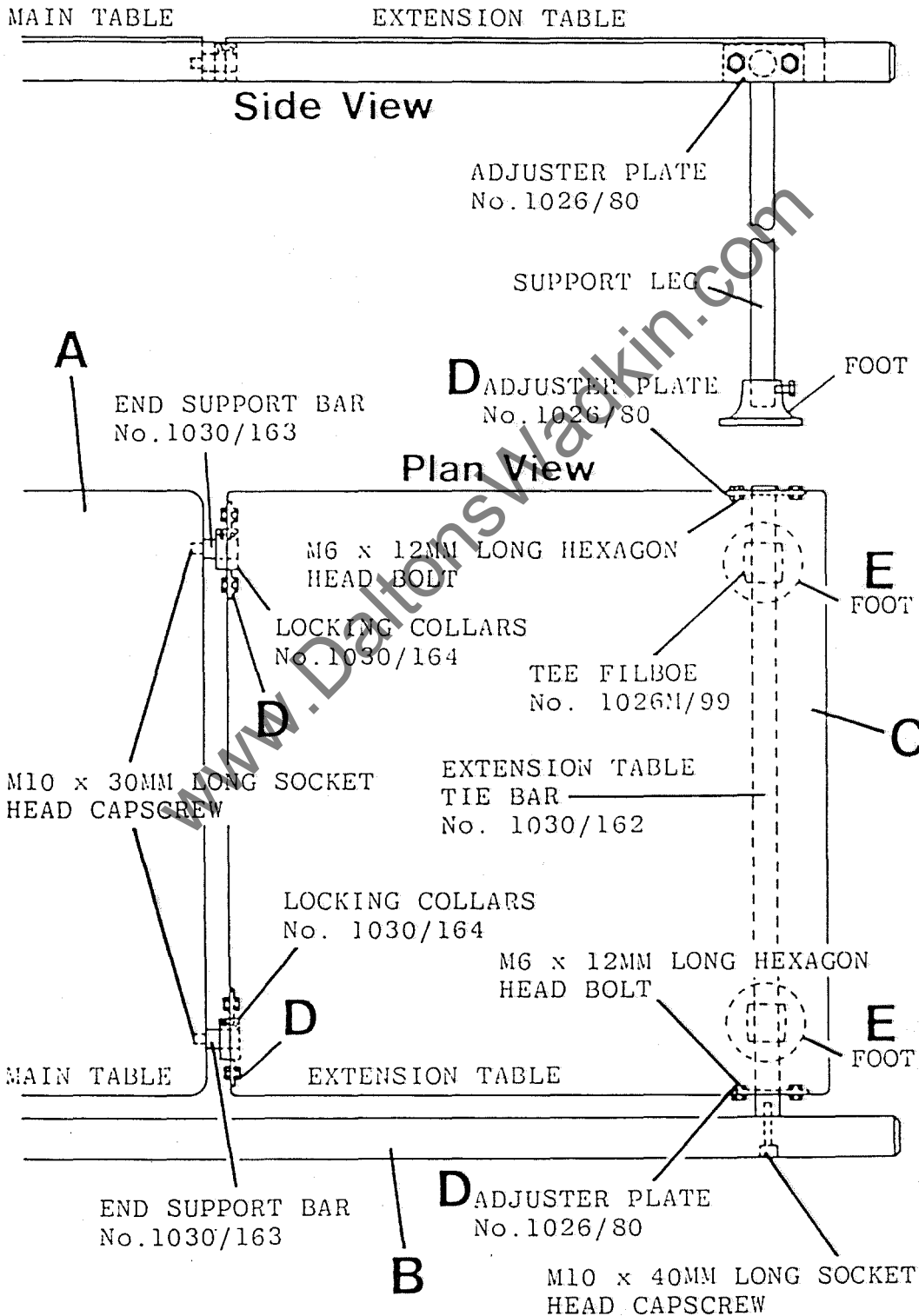

FIG 20

MITRE FENCE

The mitre fence can be supplied as an extra, for use on either side of the saw and slides in a tee slot, which should be kept clean.

The mitre fence can be locked in the table tee slot by grubscrew "A" in FIG 21.

USE OF MITRE FENCE STOP RODS

Accurate repetitive cutting can be made using the stop rods, see FIG 22.

The rods are held in the fence by the thumbscrews "B" in FIG 21 and the stop rods held together by the two clamps "C"

To adjust the rods by the clamps loosen the wingnuts "D".

See FIG 22 for several positions in which the stop rods can be used.

NOTE:- Take care that the stop rods are always set clear of the saw or serious damage will result to the sawblade and the user.

SAFETY PRECAUTIONS

Always adjust the guard to protect as much of the saw as possible and fit the riving knife $\frac{1}{4}$ " (6 mm) behind the saw at the rear. These adjustments are previously described.

Use a push stick, as FIG 23 as much as practicable when feeding timber, to avoid accidents.

When changing the sawblade, always isolate the machine electrically.

SAW MAINTAINANCE

Efficient operation of a circular saw depends on the true running of the saw spindle and the collars being perfectly square on the faces with the axis of the spindle, it must run at the correct peripheral speed to ensure straight cutting.

All Bursgreen circular saw benches embody these requirements and provided the sawblade is maintained in a sharp condition with the teeth correctly sharpened and set, efficient service will be given.

Before putting a new saw into use, it is essential that it is "ranged down" on the teeth, to ensure each tooth is cutting and to maintain true running.

R ANGING

Ranging down should be done on a new saw or any saw after the fourth or fifth re-sharpening.

To range down a saw, feed a square edge abrasive block in wooden holder, as shown in FIG 24 lightly against the saw teeth whilst running. The saw should then be removed and the tops of the teeth filed to remove the ranging marks on the points.

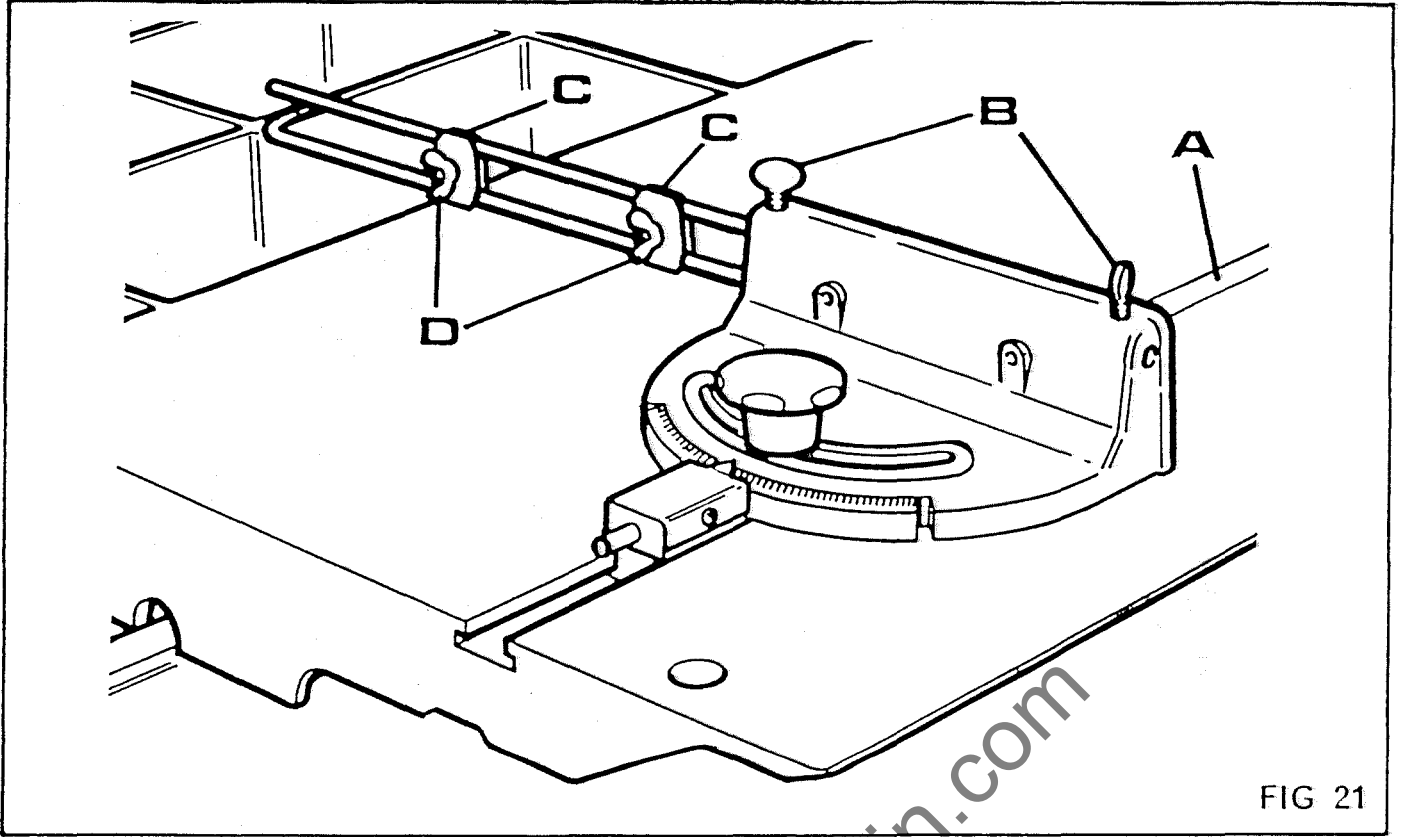

FIG 21

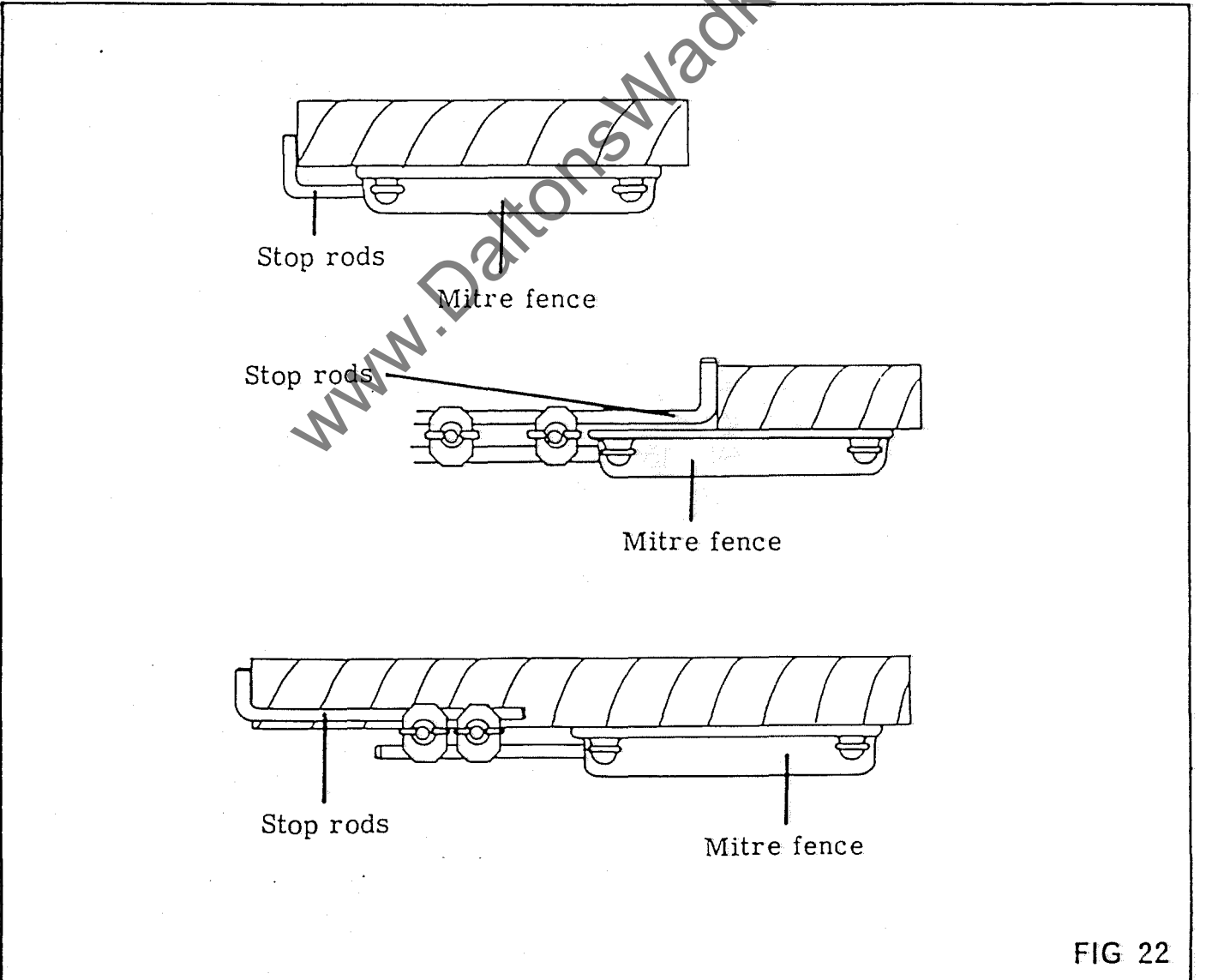

FIG 22

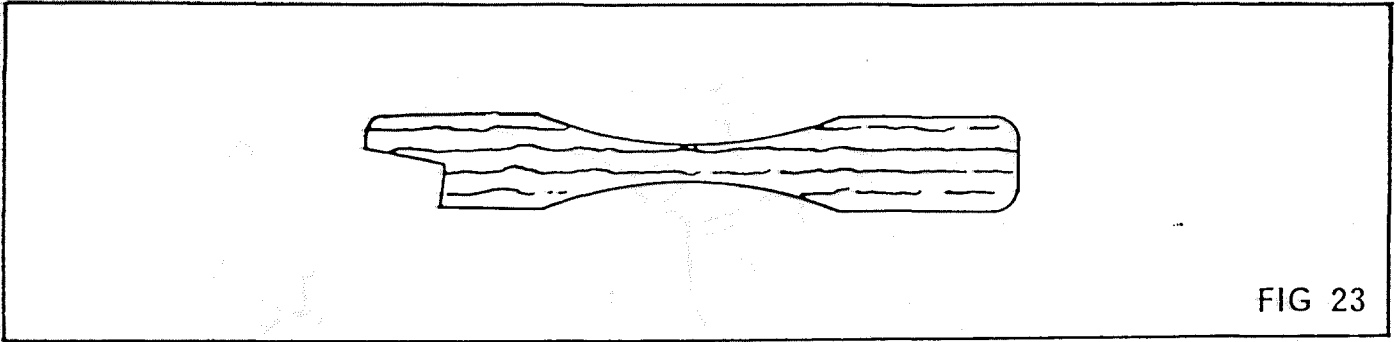

FIG 23

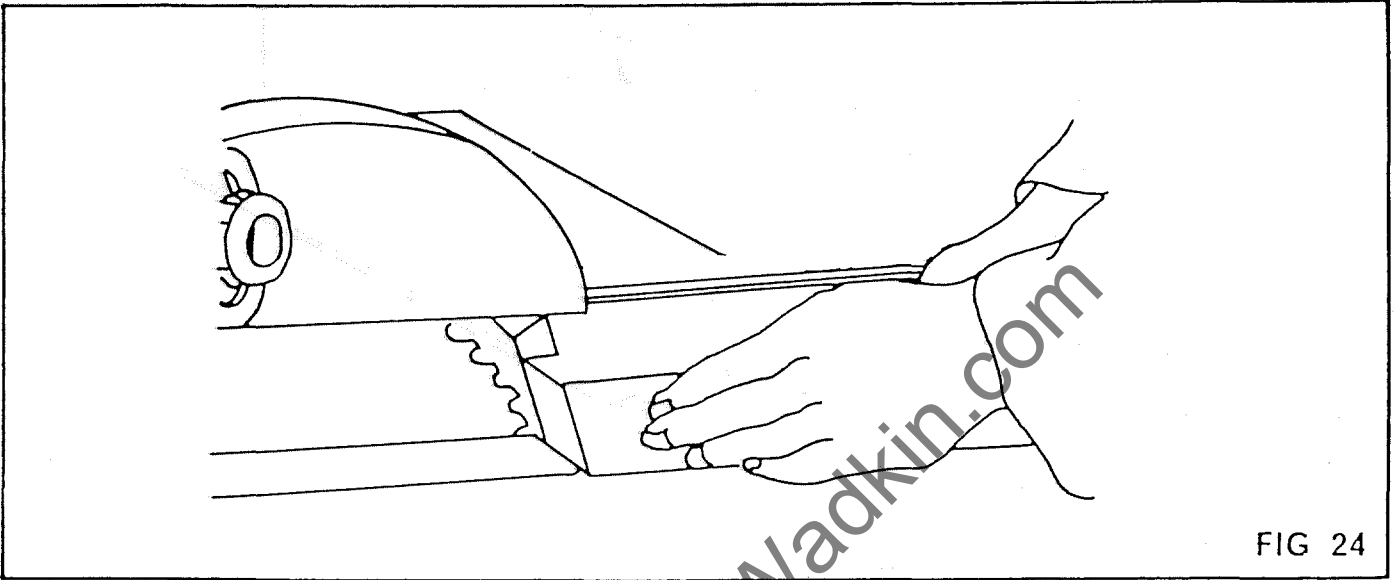

FIG 24

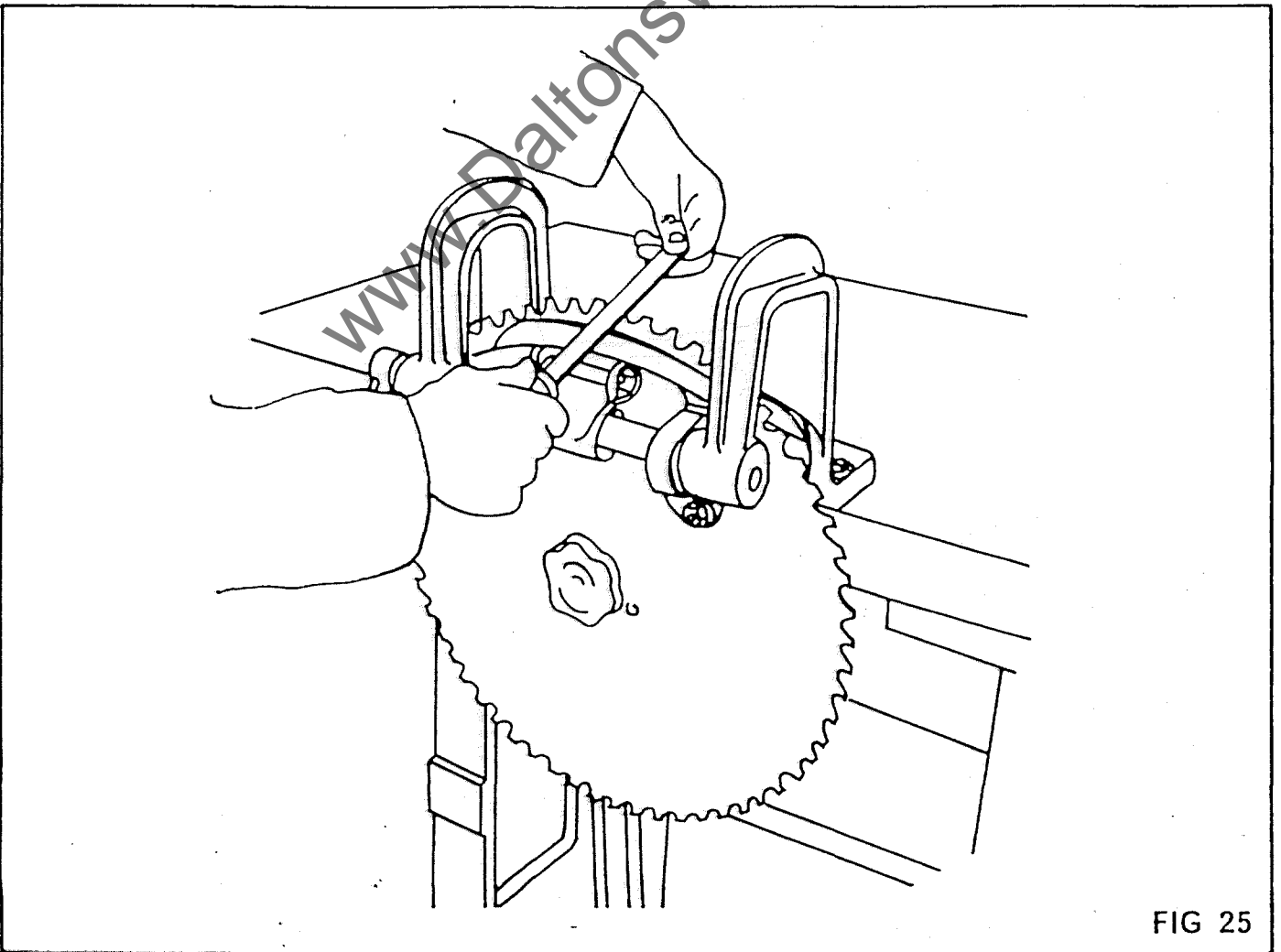

FIG 25

SAW SHARPENING

Do not run a saw when blunt, remove and re-sharpen. To sharpen by hand hold the saw rigid in a vice, as shown in FIG 25 then proceed to sharpen the saw.

With rip saw teeth chisel edges and square faces are required, see FIG 26. Sharpen by giving each tooth an equal number of strokes with a flat face saw file with rounded edges. At the same time file the gullet, taking care to keep the gullet well rounded.

With a crosscut saw, points are needed with back and front bevels as FIG 27.

In the case of repeated filing the teeth loose the original shape and the gullets shallow. To restore the shape of each tooth essential for satisfactory performance, it is necessary to grind the saw on a saw sharpening machine. These machines are usually of the automatic type and feed each tooth giving equal spacing or pitch.

SETTING

The amount of set to the teeth should be sufficient to give clearance to the body of the saw, so that there is freedom from friction between saw and timber. It is generally accepted that the teeth are "Spring set" i.e. tips of alternate teeth are bent to the right and left, as shown on FIG 28. For good sawing the amount of set on each side of the saw must be identical, otherwise the saw will run to one side. To check the set, cut into a piece of wood a few inches when a small even triangle should be cut, as in FIG 29.

The exact amount of set each side varies with the timber being cut, usually .010" to .015" (.3mm to .4mm)

For clean cutting, just sufficient set should be allowed to prevent bending and heating. More set is required for wet woolly timber than for dry close grained timber and the amount of set is greater for crosscutting saws than for ripping.

MACHINE SETTING

We can supply a small machine for efficiently setting the teeth, as illustrated in FIG 30 and will deal with saws 8" to 36" (202 mm to 910 mm) diameter. The micrometer dial indicates accurate reading of the amount of set in thousandths of an inch.

HAND SETTING

Where the number of saws does not warrant a machine being installed, the saws can be set by hand using a tool, as shown in FIG 31. This tool is provided with six notches to take saws 8 to 14 gauges thick.

For this process of setting, the saw should be securely clamped in a vice.

METHOD OF DUST EXTRACTION

SEE FIG 32

EXTRA EQUIPMENT

SEE PAGES 29 & 30

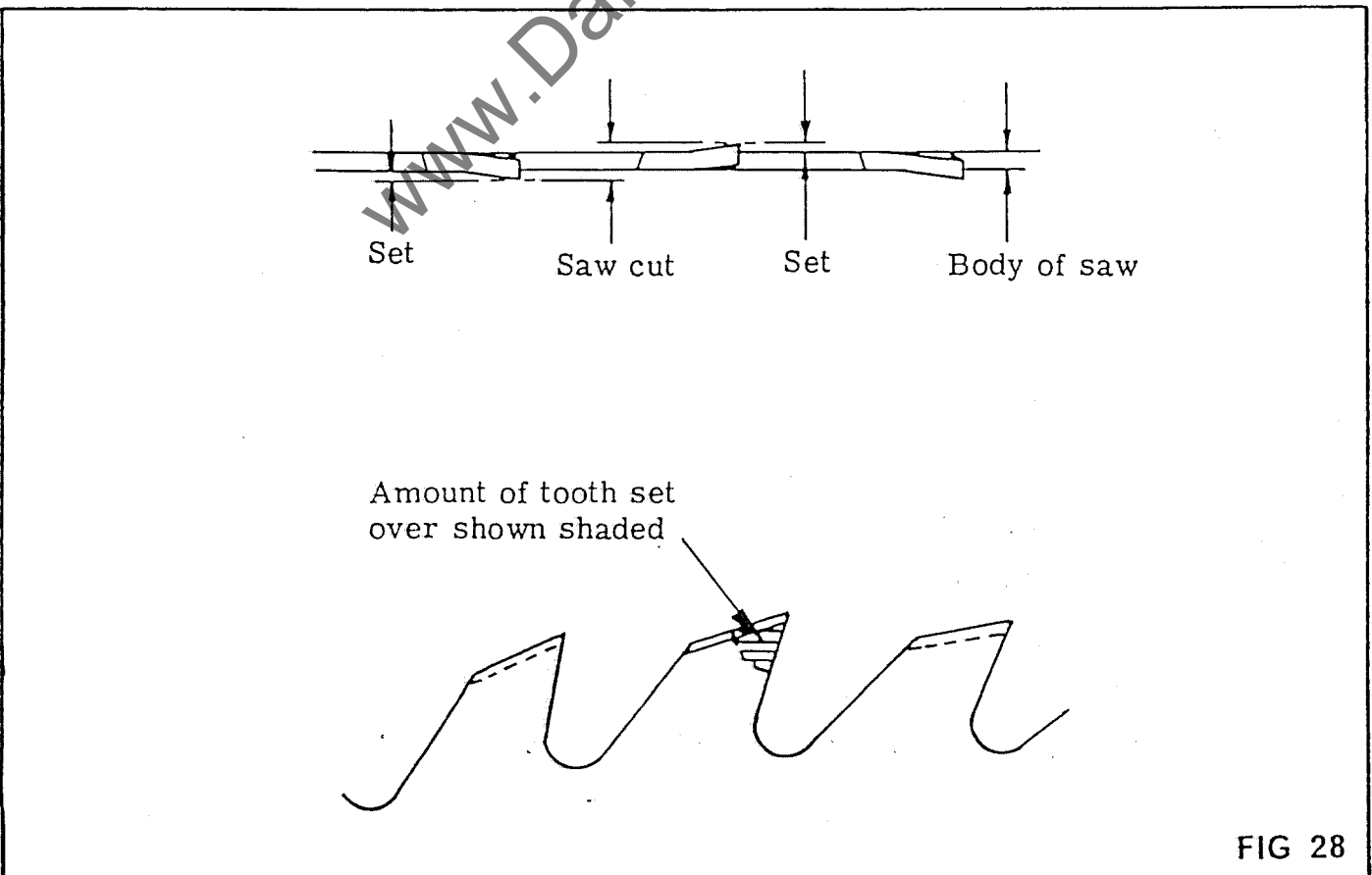
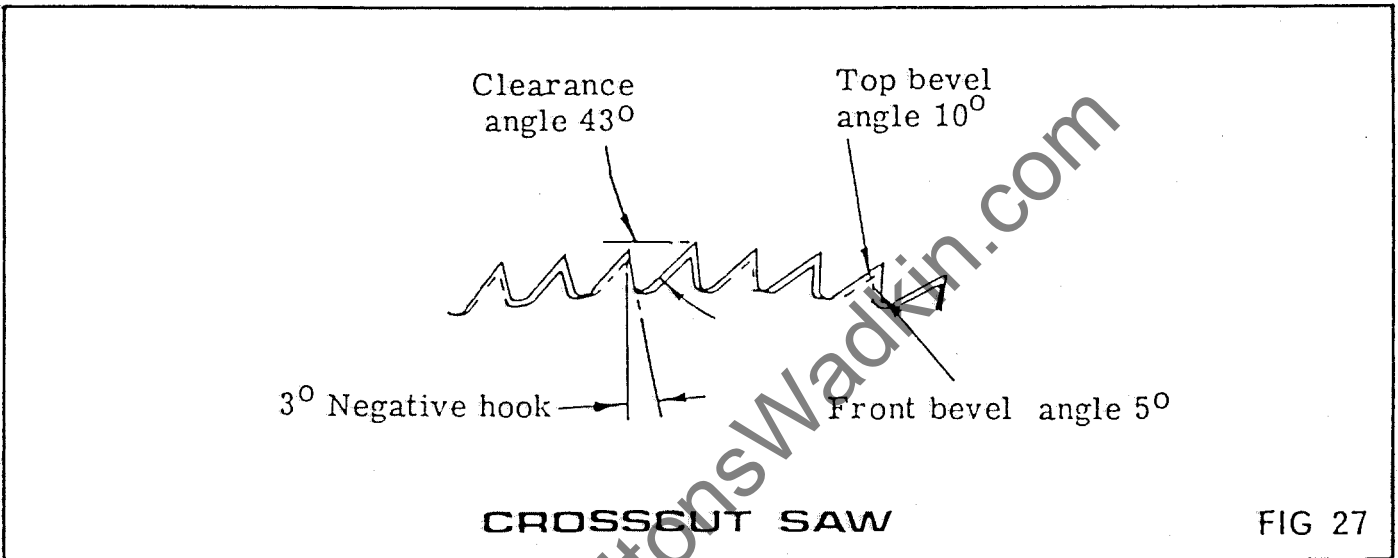
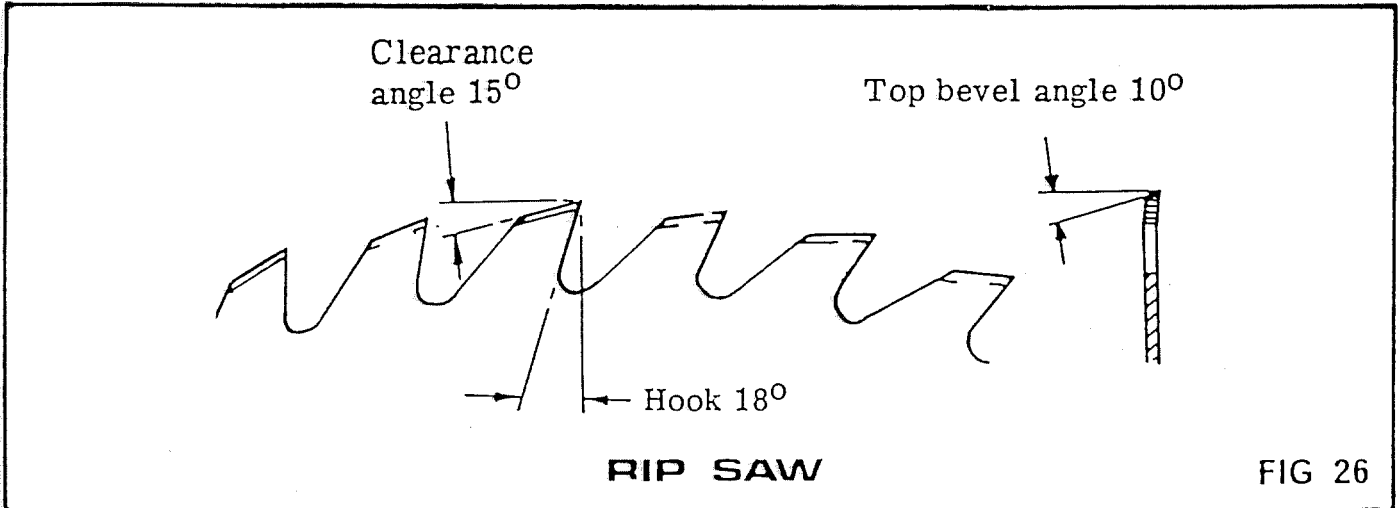

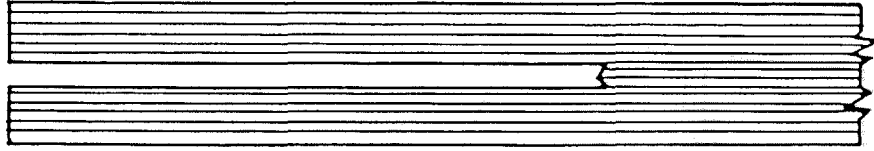

FIG 29

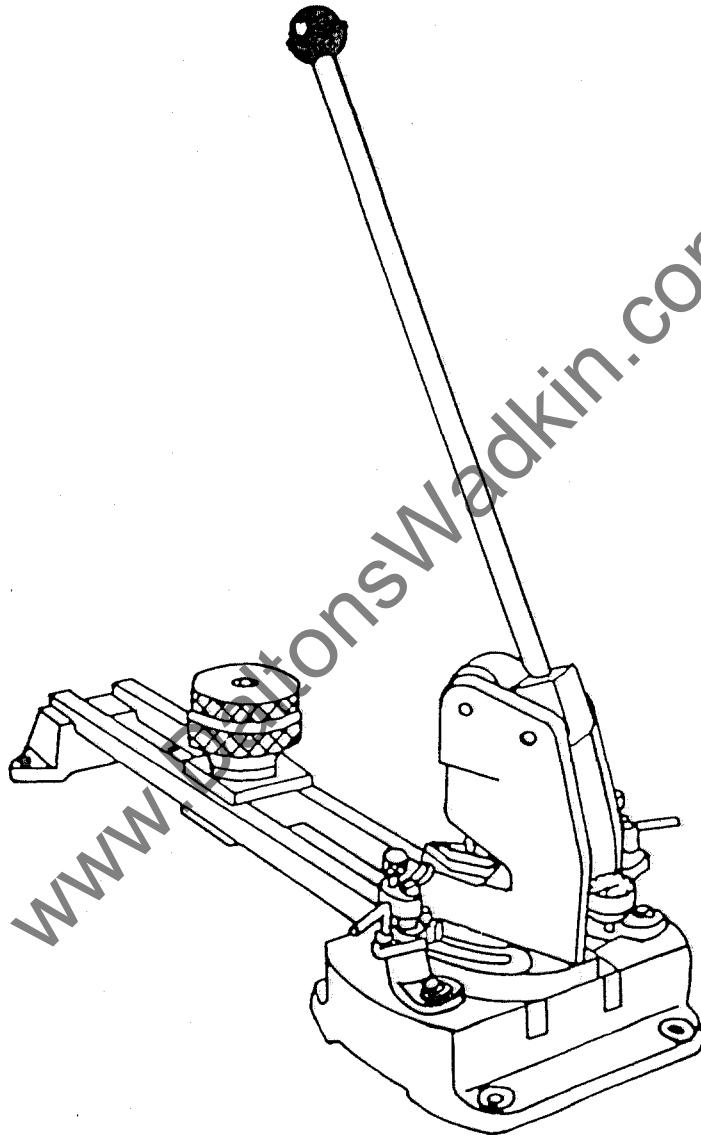

FIG 30

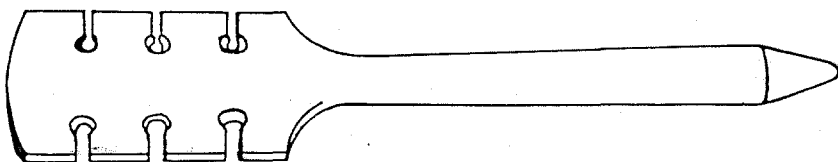
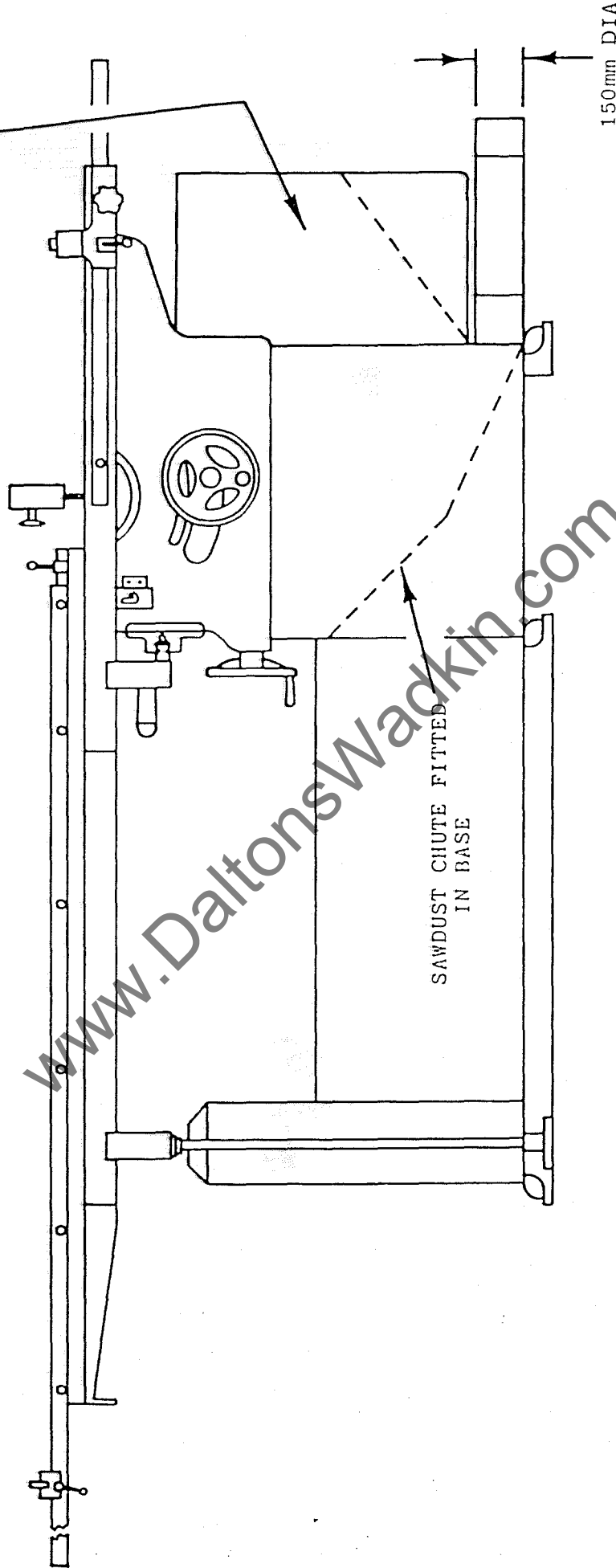

FIG 31

SPECIAL DOOR WITH
EXHAUST CHUTE
No. 1041/129



150mm DIA

SAWDUST CHUTE FITTED
IN BASE

METHOD OF DUST EXTRACTION

FIG 32

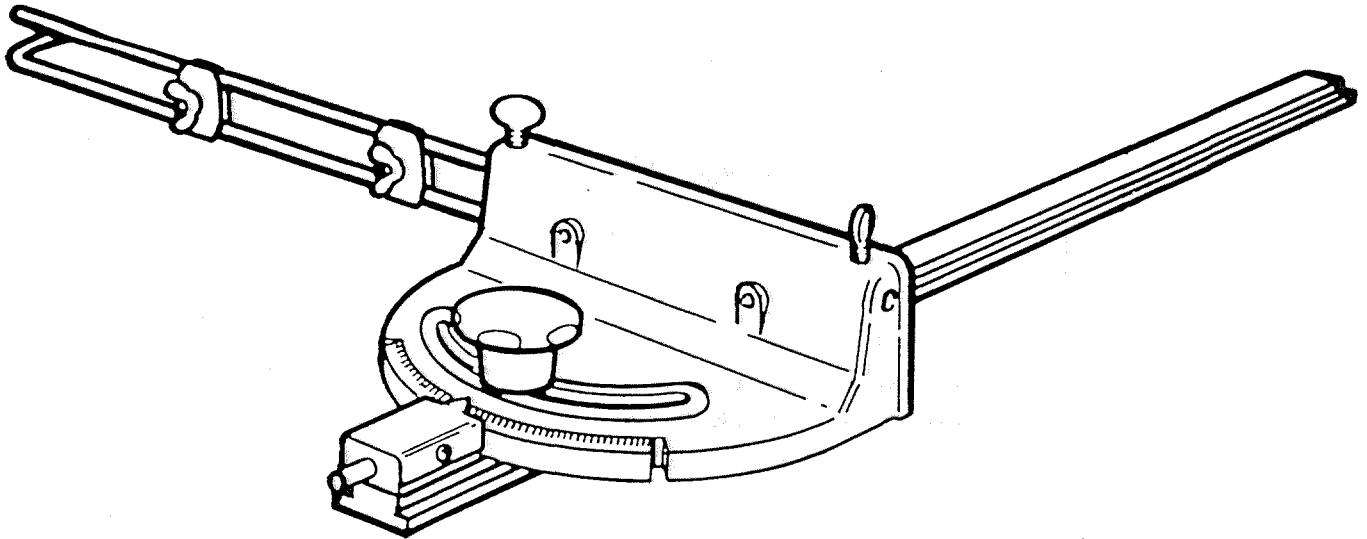
EXTRA EQUIPMENT

Adjustable mitre fence complete with stop rods for use on either side of the saw. The fence slides in tee slots in the tables of the machine.

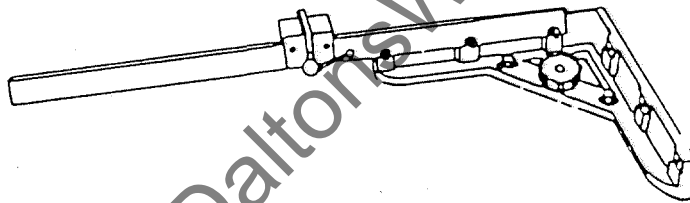

Fixed mitre fence locates accurately in the tee slot in the sliding table. Complete with graduated stop bar and turnover stops.

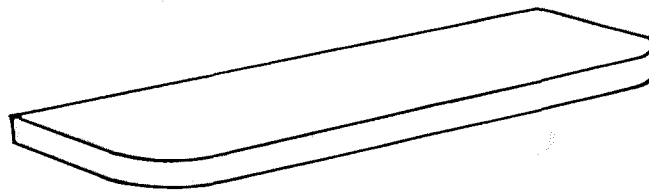

Fixed extension table to right of saw, 12" wide, increases the capacity between saw and rip fence to 37" (940mm).

EXTRA EQUIPMENT

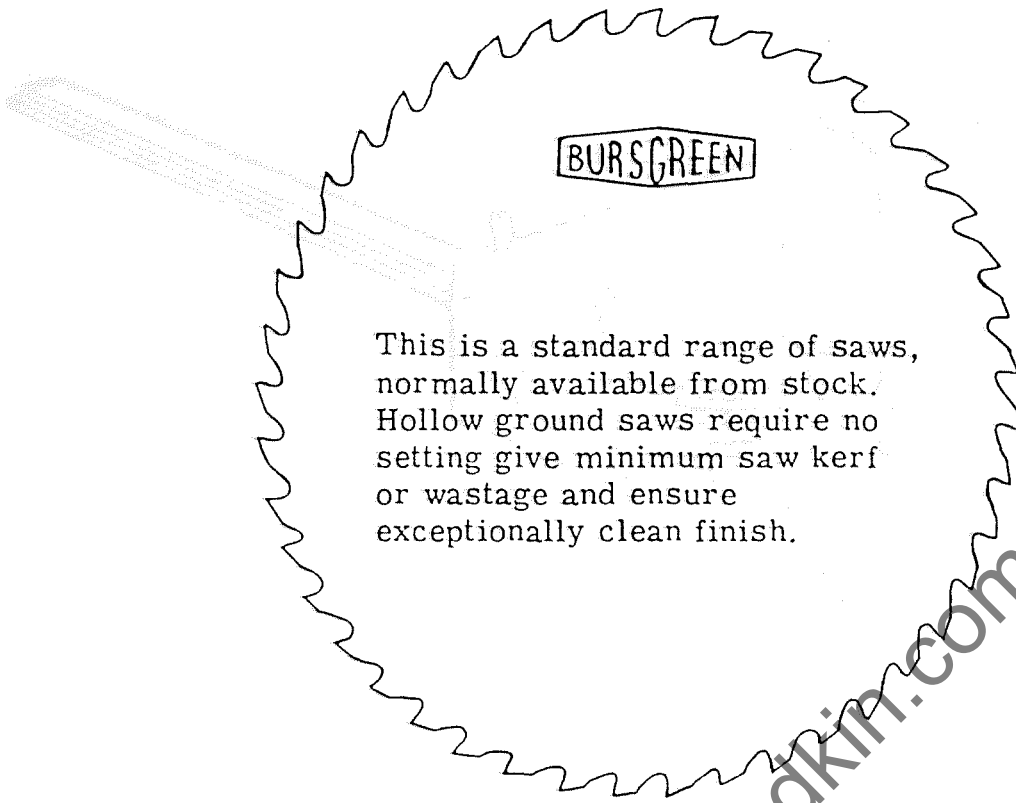

This is a standard range of saws, normally available from stock. Hollow ground saws require no setting give minimum saw kerf or wastage and ensure exceptionally clean finish.



B. S. 121
A general purpose rip saw for hard or soft woods.



B. S. 124
For crosscutting or ripping with an exceptionally smooth finish.

B. S. 125
As above but hollow ground.



B. S. 122
A general purpose crosscut stops saw.



B. S. 123
A general purpose hollow ground crosscut saw.



B. S. 129
For plastic materials,

SPARE PARTS LISTS

www.DaltonsWadkin.com

**When ordering replacement parts quote
Part No. and Serial No. of the machine**

MAIN FRAME ASSEMBLY

Ref. No.	Part No.	No. Off.	Description.	Ref. No.	Part No.	No. Off.	Description.
1	1041/8	2	Pillar for outer rail.	35		6	M10 x 25 long stud.
2		14	M10 x 30 long hexagon head bolt.	36	246ADS	1	MEM starter (Scoring motor, extra, 75HP, 50 cycle).
3		4	M10 x 40 long socket head capscrew (reduced shank).		RT3	1	Brook starter (Scoring motor, extra, 75HP, 60 cycle).
4		2	M10 x 50 long hexagon head bolt.				
5		4	10 washer.	37	84GADS	1	MEM starter (Main motor 3HP, 50 cycle).
6		2	M10 locknut.		RT3	1	Brook starter (Main motor 3HP, 60 cycle).
7		2	M12 x 90 long hexagon head bolt.				
8	1071M/7	1	Casting for outer stand.		RT3	1	Brook starter (Main motor 5HP, 50 cycle).
9		2	M12 nut.				
10	1002/155	2	Washer.		RT3	1	Brook starter (Main motor 5HP, 60 cycle).
11	1071M/54	1	Tie bar for outer support.				
12	1071/17	1	Base assembly.	38		1	Wadkin-Bursgreen nameplate.
13	1041/29	6	1" simplex adjusting screw.	39		2	M5 x 12 long countersunk screw.
14	1071/16	1	Large foot for base.	40		6	M8 x 20 long hexagon head bolt.
15		24	10 washer.	41	1026/17	1	Angle indicator rule.
16		2	M10 x 25 long socket head capscrew.	42		2	M3 x 12 long round head screw.
17		1	8 dia. x 40 long groverlok spring dowel.	43	1026/7	2	Trunnion trapping plate.
18	1030/31	1	Saw guard pivot.	44	1040/21	1	Under table finger guard (standard).
19	1030/80	1	Riving knife.		1040/91	1	Under table finger guard (scoring saw extra).
20		1	1 1/2" dia. plastic handwheel M10.	45		5	M6 x 12 long countersunk screw.
21		1	M10 x 30 long stud.	46		4	M10 x 50 long socket head capscrew.
22	1026M/60	1	Riving knife distance piece.	47	1026/51	4	Fence slide bar distance piece.
23		1	M10 x 12 long hexagon head bolt.	48	1028/53	1	Back fence bar.
24	1030/10	1	Saw guard.		1040/37	1	Back fence bar (37" capacity extra).
25	Z10	4	1/2" long self tapping screw.		1071/27	1	Back fence bar (60" capacity extra).
26	1041/90A	1	Scoring saw guard (Extra).	49	1041M/1	1	Main table.
27	1071/55	1	Tie tube for outer support.		1041M/1	1	Main table for scoring saw (extra).
28	1041M/15	1	Main frame (standard).	50	1028/52	1	Front fence bar.
	1041M/72	1	Main frame (for scoring saw).		1040/36	1	Front fence bar (37" capacity extra).
29	1057/148	1	1" simplex nut.		1071/25	1	Front fence bar (60" capacity extra).
30		1	25 washer.	51		4	M10 x 70 long stud.
31	1026/22	1	Washer.	52		4	1/2" simplex nut.
32	1041/92	1	Guard for scoring saw motor.	53	1040/9	4	1/2" simplex x 45 long adjuster.
33		2	1" I/D x 7/8" O/D x 1/2" long oilite bush.	54		2	3 brass washer.
34		10	M10 nut.	55	1041/18	1	Small foot for base.

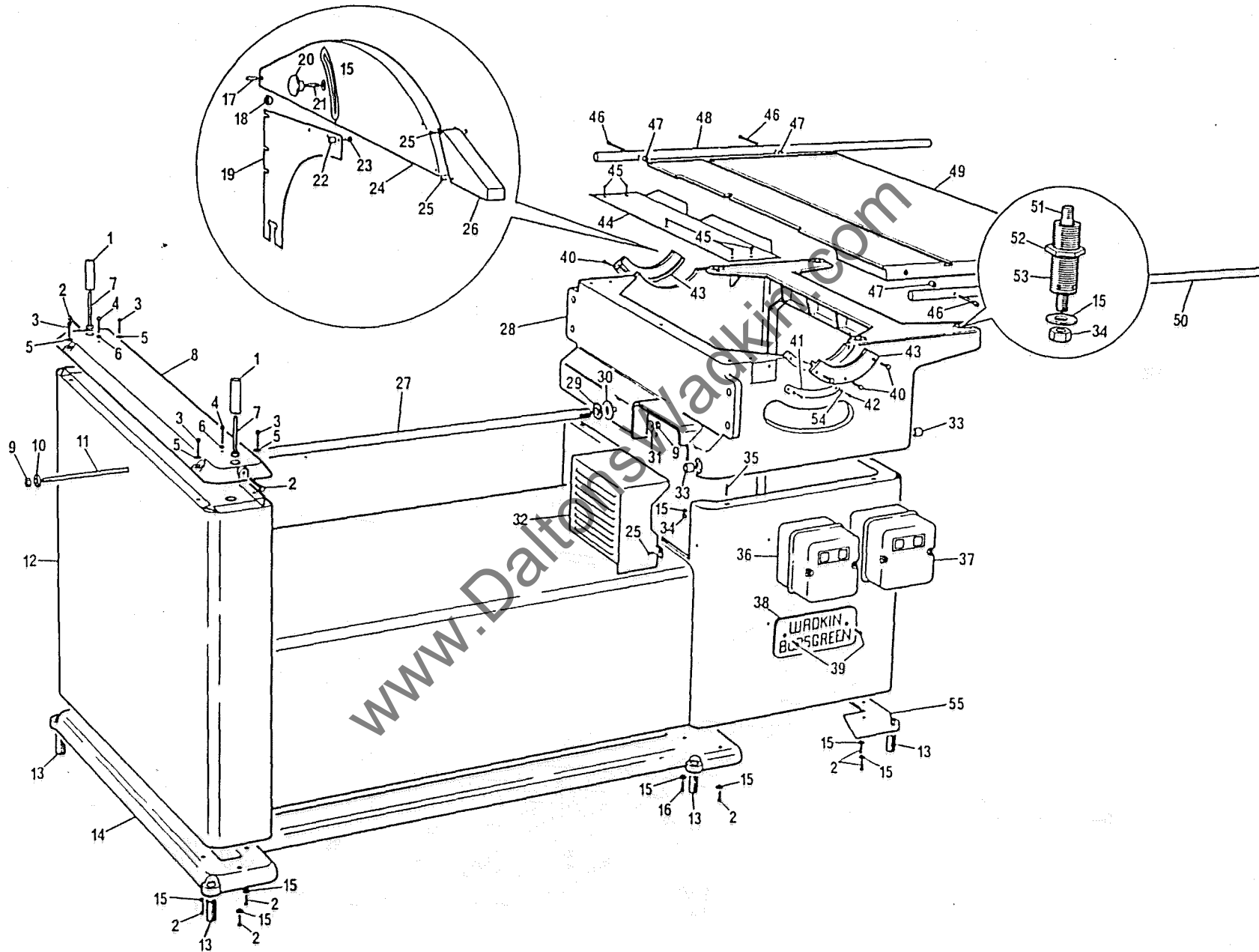

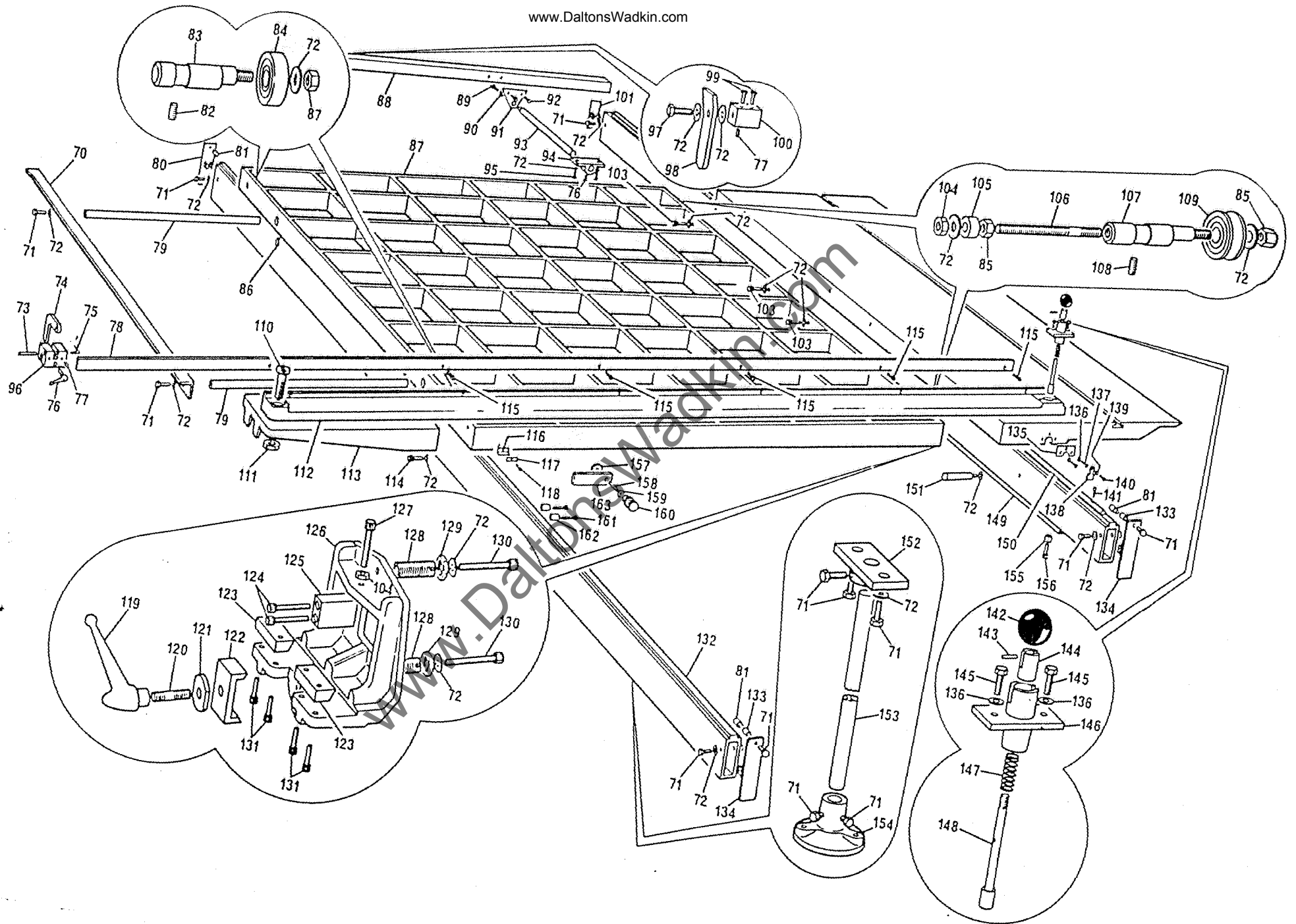

www.DaltonsWadkin.com
SLIDING TABLE ASSEMBLY

Ref. No.	Part No.	No. Off.	Description.	Ref. No.	Part No.	No. Off.	Description.
70	1071M/14	1	Outer table support.	115		5	M8 x 20 long cheese head screw.
71		17	M10 x 20 long hexagon head bolt.	116	1071/33	4	Outer rail wiper.
72		35	10 washer.	117	1071/32	4	Wiper retaining plate.
73		2	M8 dia. x 50 long groverlok spring dowel.	118		8	M5 x 30 long round head screw.
74	1028/26	2	Turn over stop.	119		1	M12 adjustable handle.
75	1027/202	2	Pointer for turn over stop.	120		1	M12 x 50 long stud.
76		4	3/8" whit short ball lever screw.	121	1002/155	2	Washer.
77		3	M5 x 10 long socket head grubscREW.	122	1071/48	2	Guide rail clamp.
78	1071/15	1	Graduated stop bar (standard).	123	1071M/46	4	Gib strips.
	1071/30	1	Graduated stop bar (metric).	124		4	M8 x 45 long socket head capscrew.
79	1071M/24	2	Outer table support bars.	125	1071M/47	2	Guide rail jacking block.
80	1071M/60	1	Outer rail end stop (rear).	126	1071M/45	2	Guide rail support bracket.
81	1027/18	3	Rubber stops.	127		2	M10 x 30 long socket head capscrew.
82		2	M10 x 10 long socket head egrubscREW.	128	1040/39	4	1/2" simplex adjuster for rail.
83	1071M/12	2	Eccentric for table roller bearing.	129		4	1/2" simplex nut.
84	FBC/DN/302	2	Table roller bearing.	130		4	M10 x 55 long socket head capscrew.
85		6	M10 nut.	131		8	M8 x 25 long socket head capscrew.
86		2	M10 x 25 long socket head grubscREW.	132	1071M/10	1	Outer rail.
87	1071M/1	1	Outer sliding table.	133	1026M/60	2	Distance piece.
88	1071M/37	1	Rear support.	134	1071M/6	2	Guide rail end stop.
89		2	M12 x 20 long hexagon head bolt.	135	1071M/5	2	Brass keep strip.
90		2	12 washer.	136		6	6 washer.
91	1071/36	2	Rear support plate.	137		4	M6 x 20 long round head screw.
92		4	M6 x 12 long hexagon head bolt.	138	1071/52	4	Guide bar wiper.
93	1071M/38	2	Rear support bar.	139		14	5 washer.
94	1041M/50	1	Outer table support bracket (1" dia. bore).	140		2	M5 x 10 long round head screw.
	1041M/50	1	Outer table support bracket (1.1/16" dia. bore).	141		10	2BA x 1/2" long cheese head screw.
95		4	M10 x 25 long hexagon head bolt.	142		1	M10 x 1 1/4" dia. plastic ball.
96	1027M/83	2	Turn over stop holder.	143		1	3 dia. x 20 long groverlok spring dowel.
97		1	M10 x 40 long hexagon head bolt.	144		1	1/2" O/D x 3/8" I/D x 1/2" long oilite bush.
98	1041M/59	1	Knock down stop.	145		2	M6 x 20 long hexagon head bolt.
99		2	M5 x 10 long countersunk head screw.	146	1041/54	1	Fence plunger locating bracket.
100	1041M/60	1	Boss for knock down stop.	147	1031/50	1	Fence plunger spring.
101	1071M/13	1	Inner rail end stop (rear).	148	1041/17	1	Table plunger.
102	1071M/2	1	Sliding table.	149	1071M/44	1	Guide rail.
103		4	M10 x 40 long socket head capscrew (reduced shank).	150	1071/8	1	Slide rod for guide rail.
104	1071/57	2	Spacer for bearing guide.	151		1	No.10 pull handle.
105		2	M10 locknut.	152	1071/22	1	Table location plate.
106	1071M/56	2	Stud for eccentric for guide bearing.	153		2	M8 x 12 long button head screw.
107	1071M/11	2	Eccentric for guide bearing.	154	1031M/89	1	Under table support bar bracket.
108		2	M10 x 12 long grubscREW.	155	1071/41	1	Support leg for extension table.
109	FBC/FG/3400	2	Table roller bearing.	156	1026M/85	1	Support foot for extension table.
110	1041M/61	1	Fence pivot.	157	1071/70	1	Table location distance piece.
111		1	M20 locknut.	158		1	M8 x 35 long stud.
112	1071M/21	1	Crosscut fence.	159		1	8mm washer.
113	1071M/20	1	Fence support bracket.	160	1026/340	1	Locking knob.
114		2	M10 x 40 long socket head capscrew, (reduced shank).	161		2	M8 x 35 long socket head capscrew.
				162	1071/69	2	Table location bobbin.
				163	1071/68	1	Table location lever.

35
156
041

SAW SPINDLE ASSEMBLY

Ref. No.	Part No.	No. Off	Description
170	1040/10	1	Saw spindle nut (1" acme)
171	1030/18	1	Front saw flange (1" bore)
	1030/67	1	Front saw flange (25mm bore)
172	1040/11	1	Saw spindle
173		1	5/16" Woodruff key
174	1030/51	1	Saw spindle pulley (3HP, 50 cycles) (3HP, 60 cycles)
	1030/73	1	Saw spindle pulley (5HP, 50 cycles)
	1030/68	1	Saw spindle pulley (5HP, 60 cycles)
175	1030/20	1	Saw spindle locknut (1" fine thread)
176		2	M6 x 10 long socket head grub screws
177	1030M/23	1	Saw spindle locking collar
178	5G.88506	2	SKF Sealed Bearing <i>K. 0601964</i>
179		1	M10 x 30 long hexagon head bolt
180	1030M/22	1	Saw spindle trapping collar
181	1030/21	1	Saw spindle distance piece

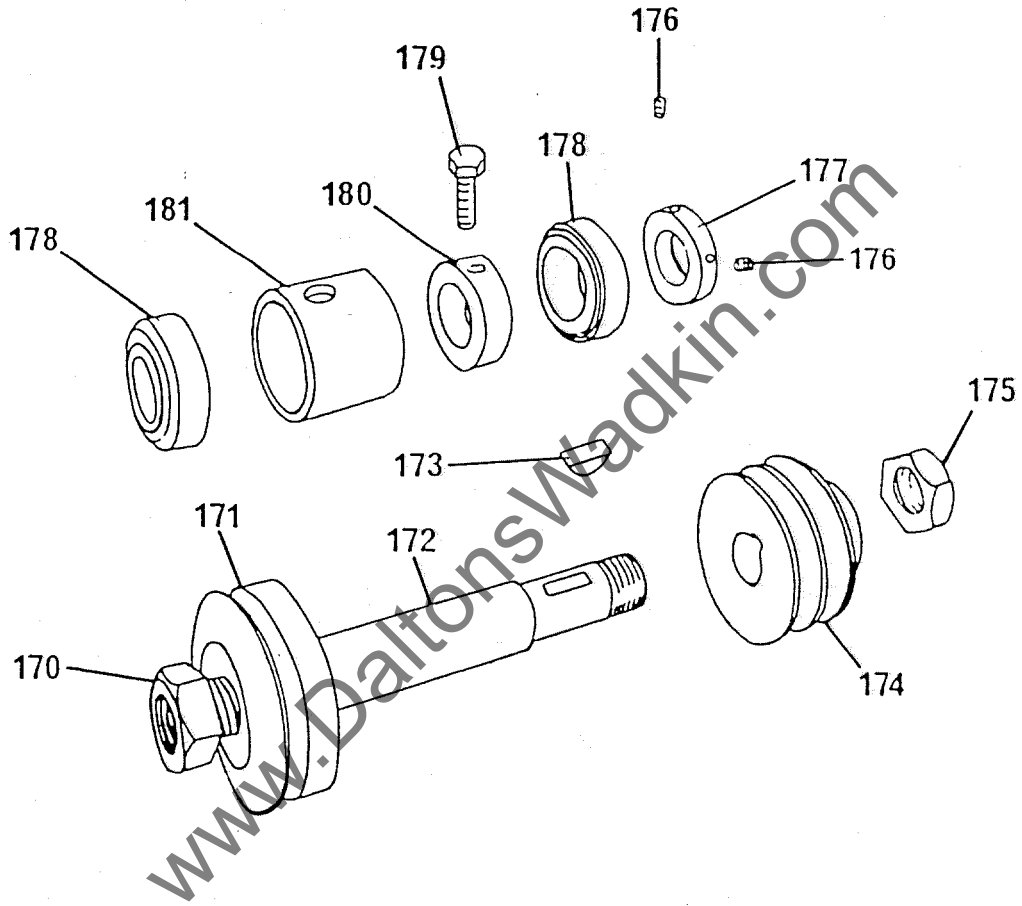

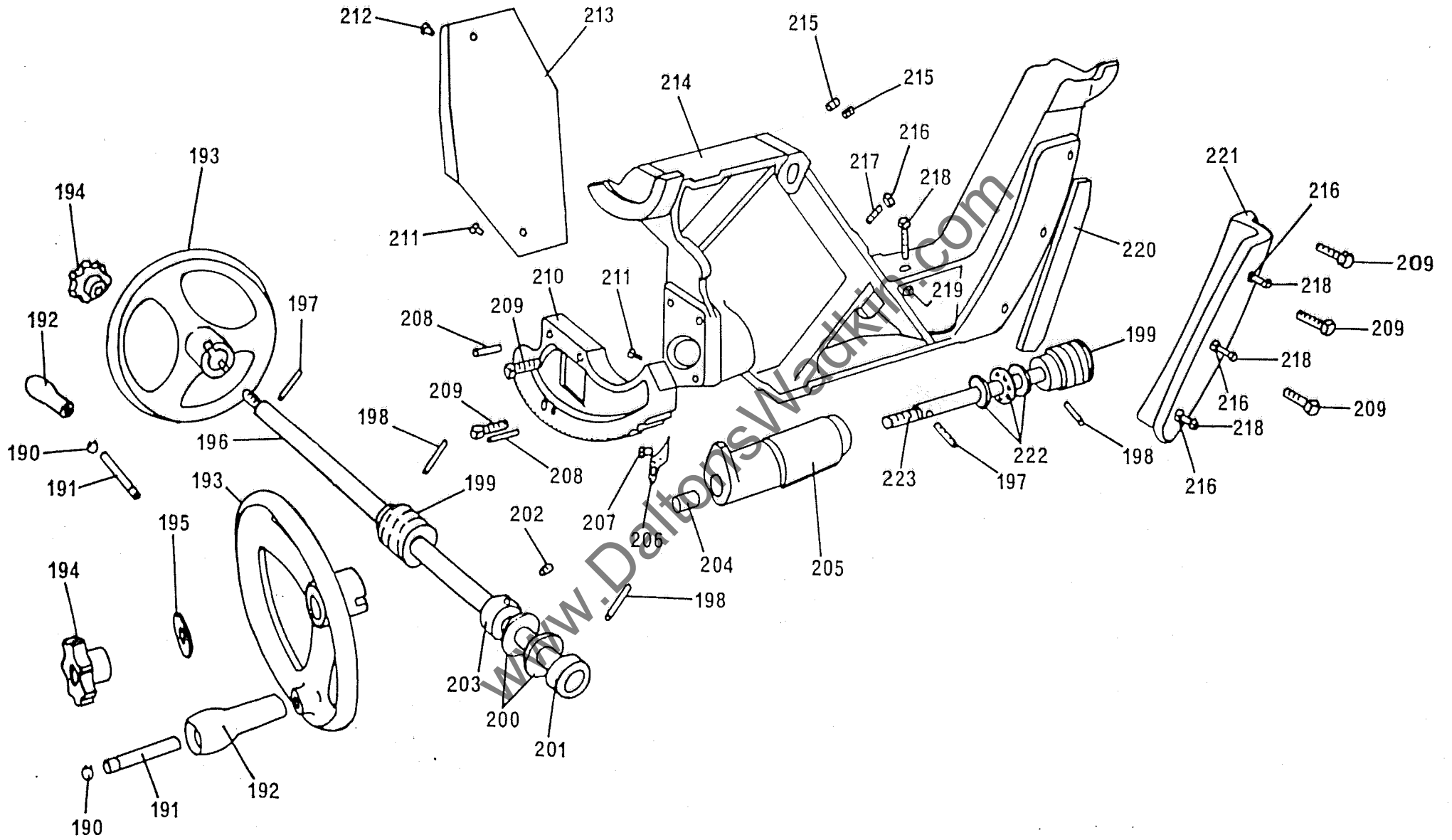

TRUNNION ASSEMBLY

Ref. No.	Part No.	No. Off	Description
190	5555-37	2	"Truarc" grip ring circlip
191	A-S-101	2	Spindle for 3" plastic handle
192	Patt. No. 4	2	3" plastic handle
193	C-1030/14	2	7½" dia dished handwheel
194	Patt.No. 14	2	2" dia plastic handwheel ½" whit TRT
195	1026/22	2	Washer for handwheel
196	1071M/50	1	Canting shaft
197		2	5 dia x 40 long groverlok spring dowel
198		3	5 dia x 30 long groverlok spring dowel
199	1026M/32	2	Worm for R & F and canting
200	1026/65	2	Fibre washer for canting shaft
201	1026M/29	1	Canting shaft collar(without M10 hole)
202		1	M10 x 12 long socket head grubscrew
203	1026M/29	1	Canting shaft collar (with M10 hole)
204		2	3/4" bore x 7/8"o/d x 3/4" long Oilite bush
205	1026M/6	1	Rise and Fall shaft bearing
206	1030/38	1	Angle indicator pointer
207		1	M6 x 10 long round head screw
208		2	8 dia x 30 long groverlok spring dowel
209		5	M10 x 30 long hexagon head bolt
210	1030/11	1	Racked quadrant for canting
211	1026/33	1	¼" gas pipscrew
212		2	M6 x 12 long hexagon head bolt
213	1030/26	1	Chip guard
214	1030M/3	1	Trunnion bracket
215		2	1/8"gas x ½"long socket head grubscrews
216		4	M6 locknut
217		1	M6 x 30 long nicked grubscrew
218		4	M6 x 30 long square head bolt
219		1	M6 nut
220	1030/28	1	Retaining strip for motor bracket
221	1030M/8	1	Motor bracket trapping piece
222	EW ³ / ₄	1	Hoffman thrust race
223	1026/20	1	Rise and fall shaft

MOTOR MOUNTING ASSEMBLY

Ref. No.	Part No.	No. Off	Description
230	1030M/81	1	Riving Knife bracket trapping bolt
231		2	M10 aerotight nut
232	1024/58	1	Riving knife retaining washer
233		1	M10 x 30 long stud
234	1030M/78	1	Riving knife bracket
235		2	M10 nut
236	1032/22	1	Riving knife washer
237	1026/96	2	Bolts for riving knife
238		1	10 washer
239		2	M8 x 20 long socket head capscrew
240	1030/79	1	Riving knife pivot bracket
241	1030M/105	1	Slide bracket
242	1030M/106	1	Spindle housing
243		3	M10 x 25 long hexagon head bolt
244	1030/107	1	Motor platform
245		12	10 washer
246		4	M10 x 20 long hexagon head bolt
247		4	M10 nut
248		6	M10 x 30 long hexagon head bolt
249		1	3/16" wide x 1 1/4" long key
250		1	Brook 66B motor, foot mounted 3HP, 3000 r.p.m. (3HP, 50 cycles)
		1	Brook 66B motor, foot mounted 3HP, 3,600 r.p.m. (3HP, 60 cycles)
		1	Brook D100L, foot mounted 5HP, 3,000r.p.m. (5HP, 50 cycles)
		1	Brook D100L, foot mounted 5HP, 3,600r.p.m. (5HP, 60 cycles)
		1	Brook D100L, foot mounted 3HP, 3,000r.p.m. (1 phase, 50 cycles)
251		2	M8 x 12 long socket head grub screws
252	1030M/52	1	Motor pulley (3HP, 50 cycles)
	1030M/54	1	Motor pulley (3HP, 60 cycles)
	1030M/72	1	Motor pulley (5HP, 50 cycles)
	1030M/69	1	Motor pulley (5HP, 60 cycles)
	1030M/52	1	Motor pulley 24mm bore (1 phase, 50 cycles)
253	A-24	2	Vee belt (3HP, 50 & 60 cycles)
	Alpha 250	3	Fenner spacesaver vee belt (5HP, 50 & 60 cycles)
254	1030M/12	1	Racked quadrant for Rise and Fall
255		2	8 dia. x 25 long groverlok spring dowel
256	1030/27	1	Pivot pin for slide bracket

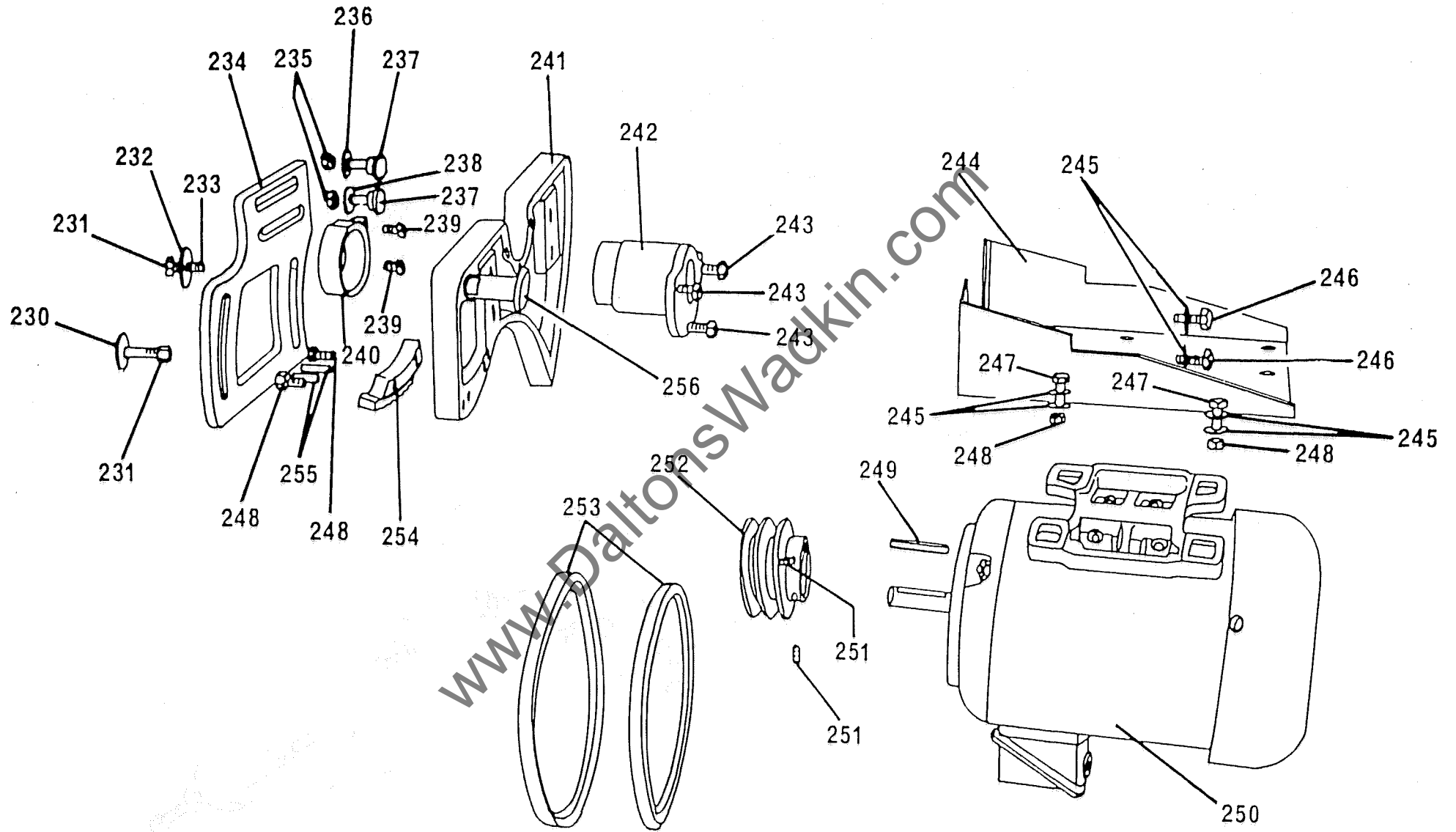

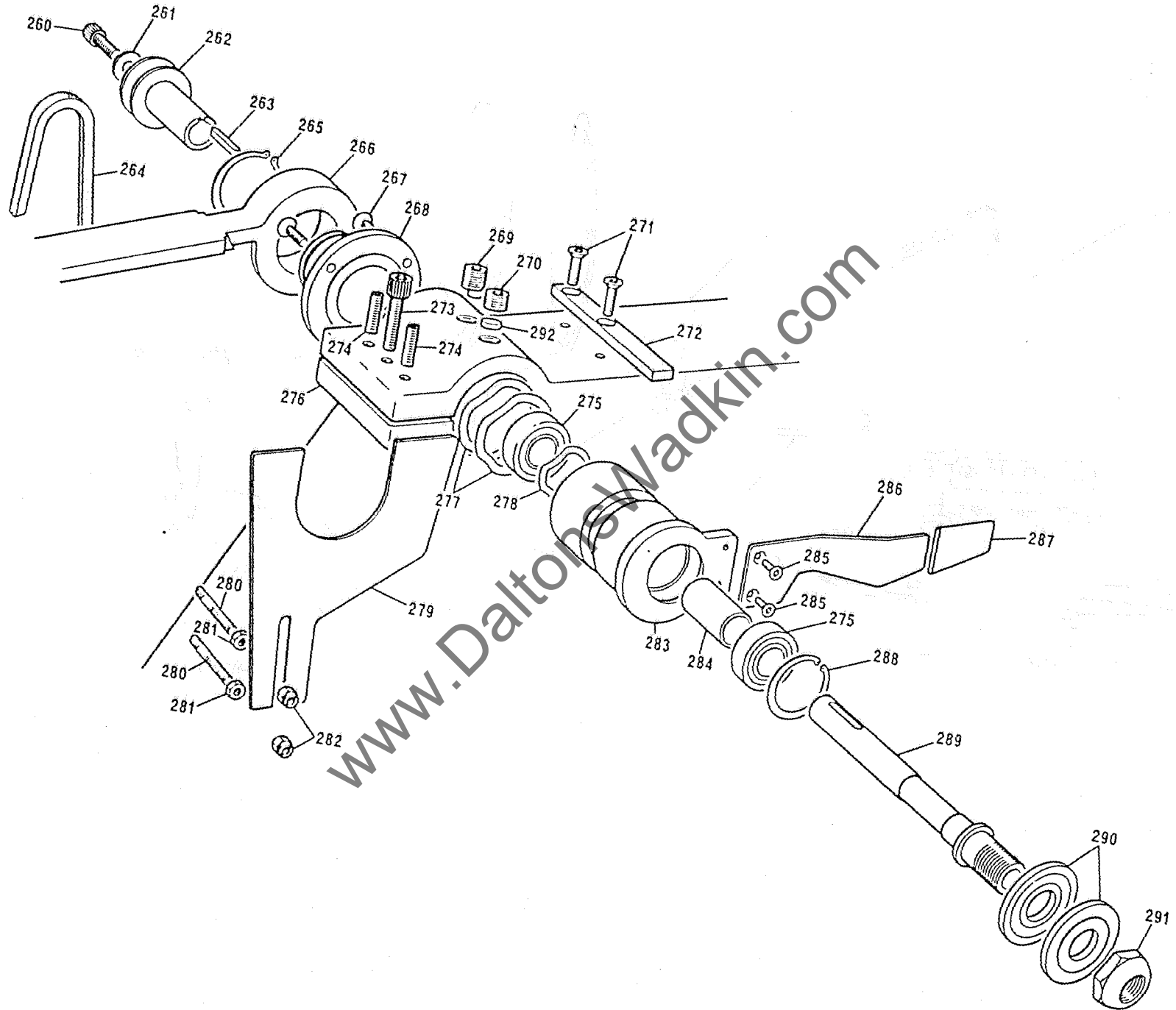

SCORING SAW ASSEMBLY (EXTRA)

<u>Ref.No.</u>	<u>Part No.</u>	<u>No.Off.</u>	<u>Description.</u>
260		1	M8 x 20 long nylock socket head capscrew.
261	1041/88	1	Washer for spindle pulley.
262	1041/67	1	Spindle pulley.
263		1	5 x 5 x 25 long feather key.
264	2400	1	"M" section vee belt.
265	7100/040	1	40mm external circlip.
266	1041/73	1	Rise and fall bracket.
267		3	M6 x 16 long countersunk socket head screw.
268	1041/82	1	Rise and fall pivot bracket.
269	1073/334	1	Adjusting screw for scorer.
270	1073/335	1	Lock screw for scorer.
271		2	M6 x 20 long countersunk socket head screw.
272	1071/60	1	Adjusting stop bar.
273		1	M8 x 30 long nylock socket head capscrew.
274		2	M8 x 20 long nylock socket head grubscrew.
275	SKF6003/2RS	2	Sealed for life bearings.
276	1041/78	1	Trunnion bracket.
277	BLP41	2	Bump washer.
278	BLP26	1	Bump washer.
279	1071/73	1	Scoring saw visor.
280	1071/72	2	M6 x 50 long stud for scoring saw visor.
281		2	M6 locknut.
282		2	M6 aerotight nut.
283	1041/74	1	Rise and fall quill.
284	1041/66	1	Bearing spacer.
285		2	M5 x 10 long countersunk socket head screw.
286	1041/86A	1	Rise and fall lever.
287		1	Red P.V.C. plastic handle.
288	7000/035	1	35mm internal circlip.
289	1041/75	1	Saw spindle.
290	1041/77	2	Saw flange.
291	1041/76	1	Saw spindle nut.
292	1073/336	1	Brass bot for scorer.

SCORING SAW MOTOR MOUNTING ASSEMBLY (EXTRA)

Ref. No.	Part No.	No. Off	Description
310		1	Totally enclosed fan cooled motor, Frame D71 Foot mounted, 0.55KW, 3,000 RPM, 3 Phase, 50 cycles
		1	Totally enclosed fan cooled motor, Frame D71, Foot mounted, 0.55KW, 3,600 RPM, 3 Phase, 60 cycles
311		2	6mm x 30mm hexagon head bolt
312		4	6mm washer
313		1	M10 x 85 long hexagon head bolt
314		4	8mm x 20mm hexagon head bolt
315		4	8mm washer
316		2	10 Washer
317	1041/79	2	Motor plate
318		2	10mm grip ring
319	1041/80	1	Spacer for motor plates
320	1041/100	1	Motor platform
321	1041/81	1	Motor pivot bar
322		1	M10 aerotight nut
323		2	6mm Aerotight nut
324		1	5mm x 5mm x 16mm feather key
325	1041/68	1	50 cycle motor pulley
326		2	8mm x 12mm socket head grubscrew

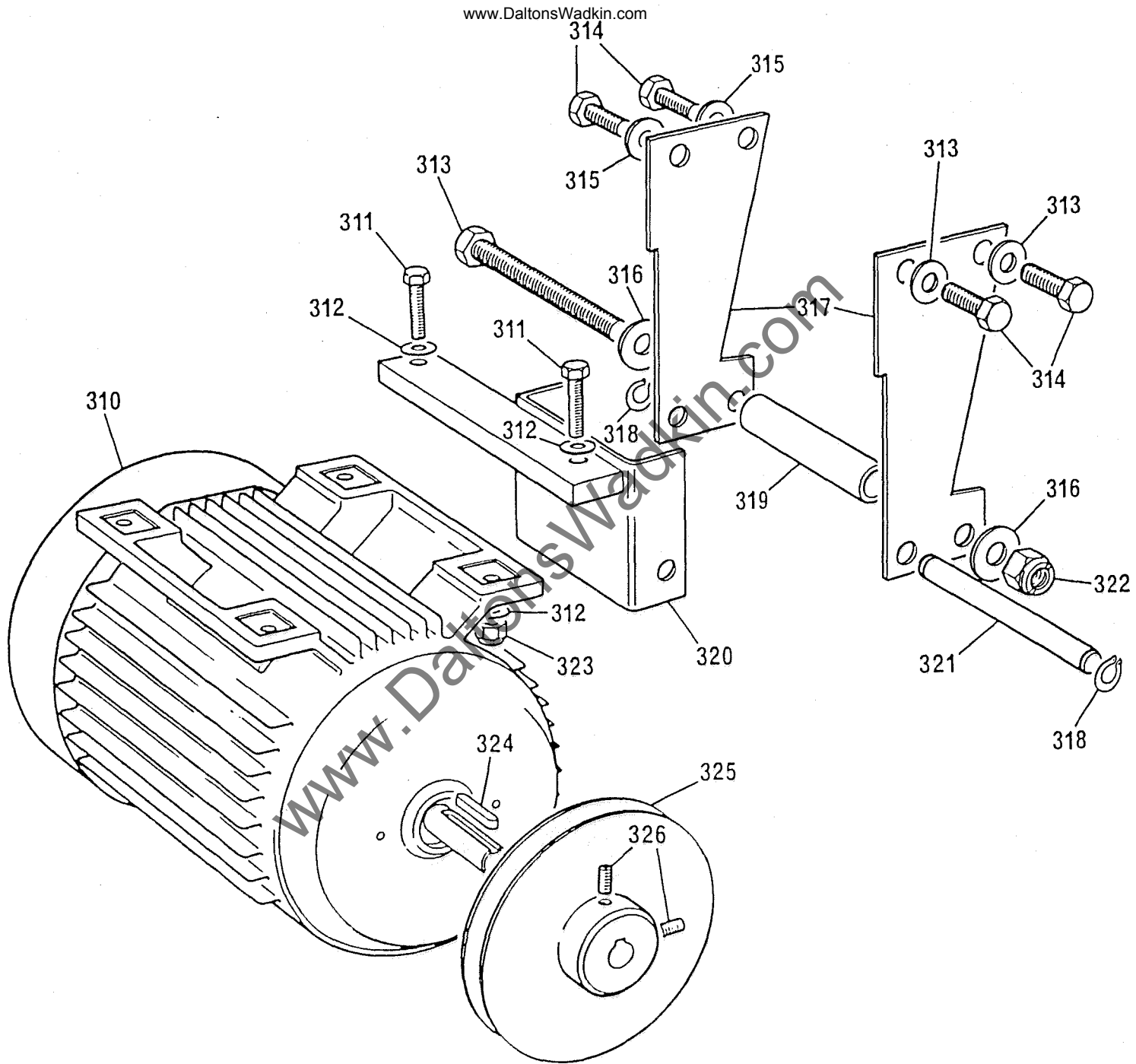

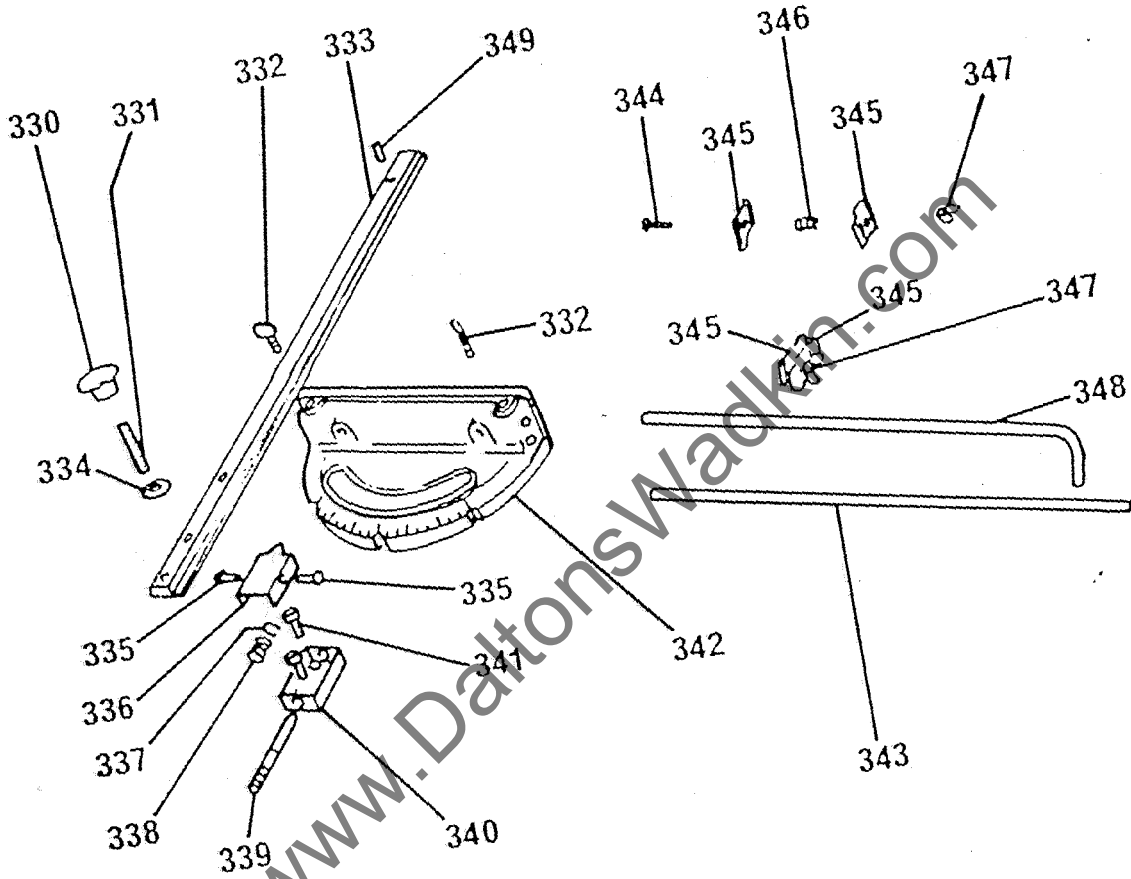

MITRE FENCE ASSEMBLY (EXTRA)

Ref. No.	Part No.	No. Off	Description
330		1	M8 bore x 1 $\frac{3}{4}$ " dia. plastic handwheel
331		1	M8 40 long stud
332		2	M6 thumbscrew
333	1041M/52	1	Mitre fence tongue
334	1026/174	1	Washer for mitre fence
335	Z4	2	$\frac{1}{4}$ " self tapping screw
336	1026/227	1	Cover for plunger bracket
337	5103-25	1	Grip ring circlip
338	ETS30	1	Mitre fence plunger spring
339	1026/226	1	Mitre fence location pin
340	1026/220	1	Mitre fence plunger bracket
341		2	M5 whit x 10 long cheese head screw
342	1026/219	1	Mitre fence body
343	1026/69	1	Mitre fence stop rod (Straight)
344		2	$\frac{1}{4}$ " whit x $\frac{3}{4}$ " long coach bolt
345	1026/68	4	Mitre fence stop plate
346	1026/73	2	Mitre fence stop plate spring
347		2	$\frac{1}{4}$ " whit wingnut
348	1026/69-	1	Mitre fence stop rod (cranked)
349		1	M8 x 12 long nicked grubscrew

AMERICAN SAW GUARD ASSEMBLY (SPECIAL)

Ref. No.	Part No.	No. Off	Description
360	1026/107	2	Back pivot screw
361		4	3/8"bore x 1/2" o/d c 1/2"long nylon bush
362	1030/63	2	American saw guard pivot arm
363		2	M6 aerotight nut
364		2	6 washer
365	1026M/108	1	Front pivot pin
366	1030/62	1	American saw guard
367	1026M/104	1	Pivot block for arm
368		1	M6 x 25 long hexagon head bolt
369	1030/32	1	Kick back finger(5.1/8" long)
370	1030/32	1	Kick back finger(4.3/8" long)
371	1026/109	2	Riving knife pivot bush
372	1030/32	1	Kick back finger (3.5/8" long)
373	1030/32	1	Kick back finger (2.7/8" long)
374		1	M6 nut

www.DaltonsWadkin.com

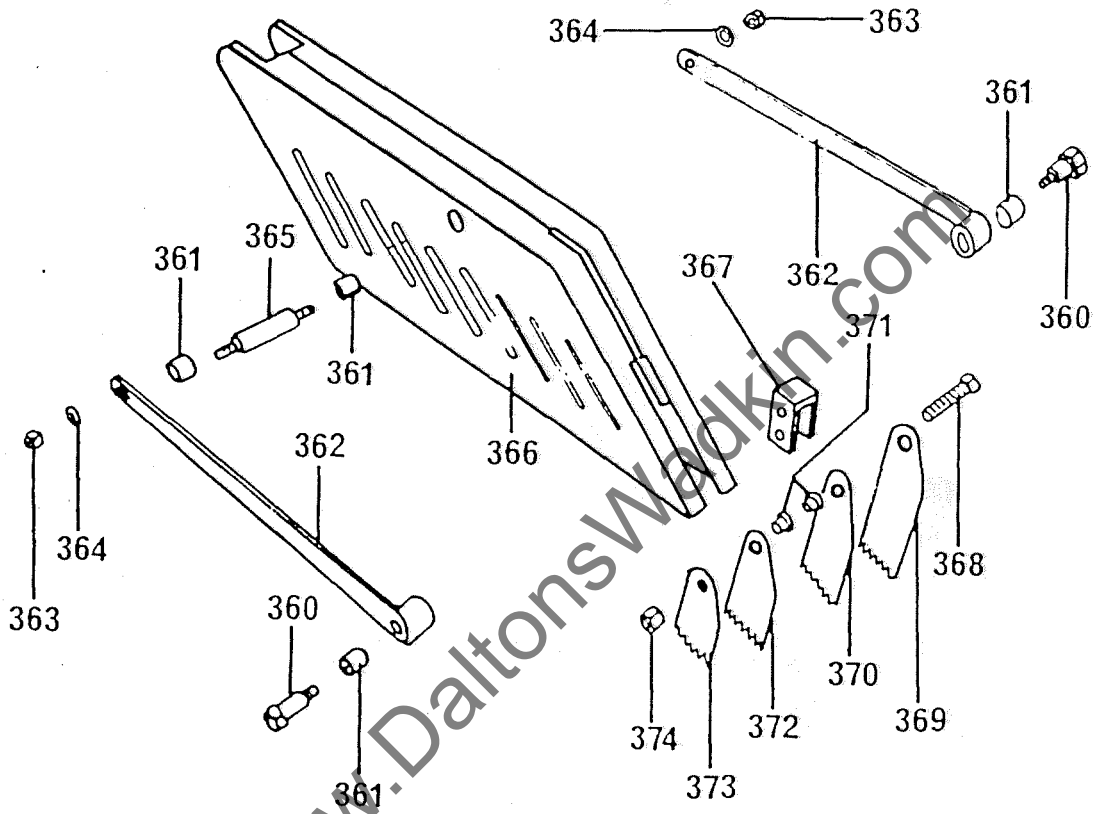

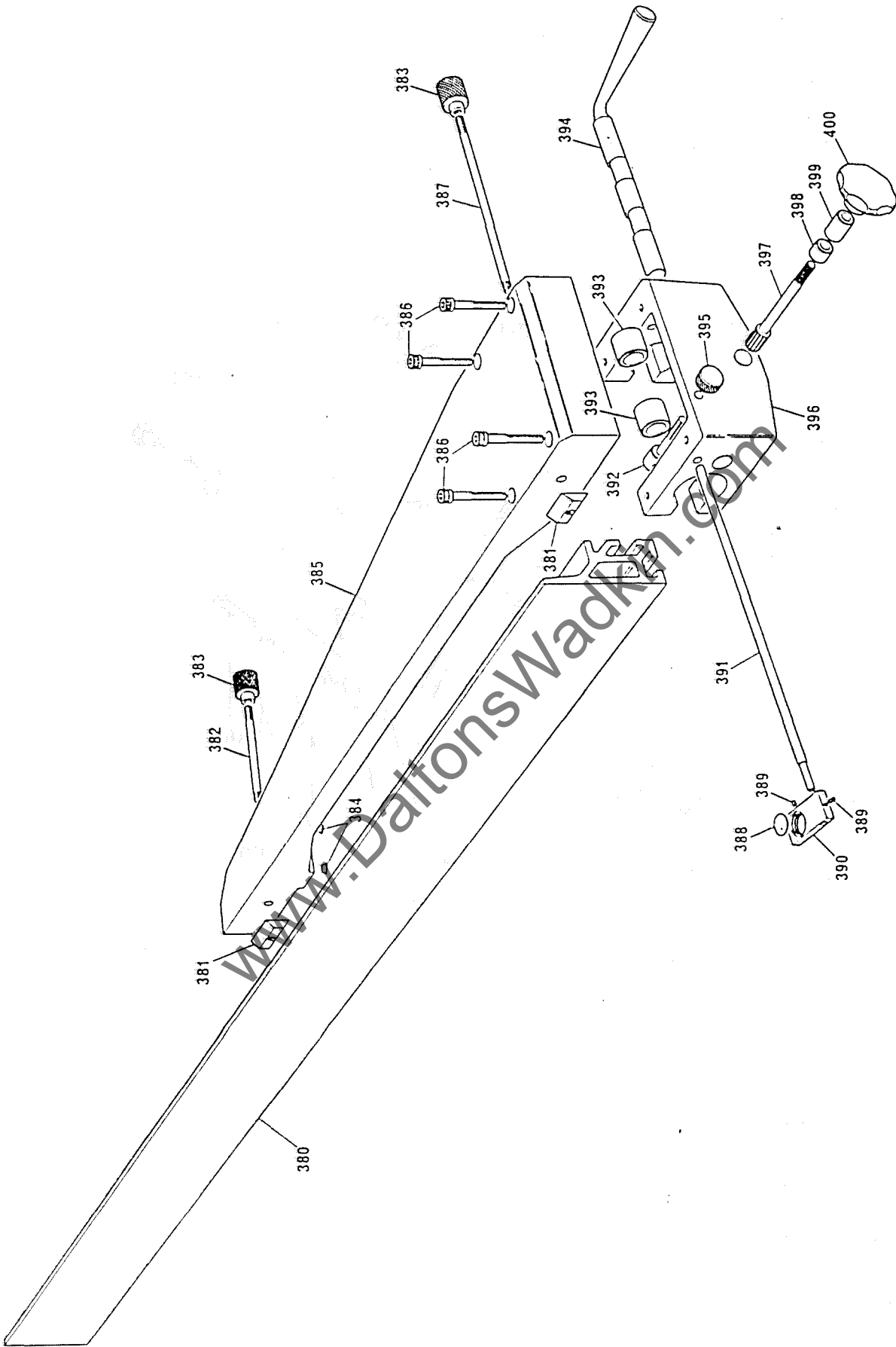

RIP FENCE ASSEMBLY

<u>Ref.No.</u>	<u>Part No.</u>	<u>No.Off.</u>	<u>Description.</u>
380	C-1085/25	1	Rip fence front plate (900mm long.)
381	A-1085/93	2	Locking plate for rip fence front plate.
382	A-1085/92	1	84mm long stud for rip fence front plate.
383	1026/340	2	Locking knobs for rip fence front plate.
384		2	10mm hexagon plastic caps.
385	D-1085/34	1	Rip fence body.
386		4	M8 x 50mm long socket head cap screws.
387	A-1085/92	1	163mm long stud for rip fence front plate.
388	5584-TYPE G3	1	Magnifier lens.
389		2	M4 x 5mm long socket head screw.
390	A-1026/323	1	Magnifier housing.
391	A-1026/320	1	Slide bar for rip fence magnifier.
392	A-1026/342	1	Locking spindle for magnifier housing.
393	A-1026/307	1	Cam lock ring for rip fence.
394	A-1026/304B	1	Cam lock shaft for rip fence.
395	A-1026/338	1	Locking knob for fence magnifier.
396	C-1085/33	1	Rip fence adjusting bracket.
397	A-1026/308	1	Pinion for rip fence.
398		1	9mm I/D x 14mm O/D x 10mm long oilite bush.
399		1	9mm I/D x 14mm O/D x 14mm long oilite bush.
400		1	2" dia. plastic handwheel, 8mm plain bore.

DOUBLE MITRE FENCE ASSEMBLY (EXTRA)

Ref. No.	Part No.	No. Off	Description
420	1040/38	1	Stop Bar (Standard)
	1040/40	1	Stop Bar (Metric)
421		1	5/16" dia. x 2" long hardened & ground dowel
422	1041/121	1	Turn over stop
423	1027/83	1	Turn over stop holder
424	1027/202	1	Pointer for turn over stop
425		1	M6 x 10 long socket head grubscrew
426		3	10 washer
427		2	M10 x 25 long Hexagon Head Bolt
428		2	6 x 25 long Fluted dowel
429	Patt. No. 32	1	1 $\frac{3}{4}$ " dia. Plastic handwheel M10
430		3	M8 x 20 long cheese head screw
431	1041M/118	1	45 ^o mitre fence
432	1041M/119	1	45 ^o mitre fence tongue
433	1041M/120	1	Fence lock bolt
434	B-S-1-B	1	3/8" whit ball lever screw

www.DaltonsWadkin.com

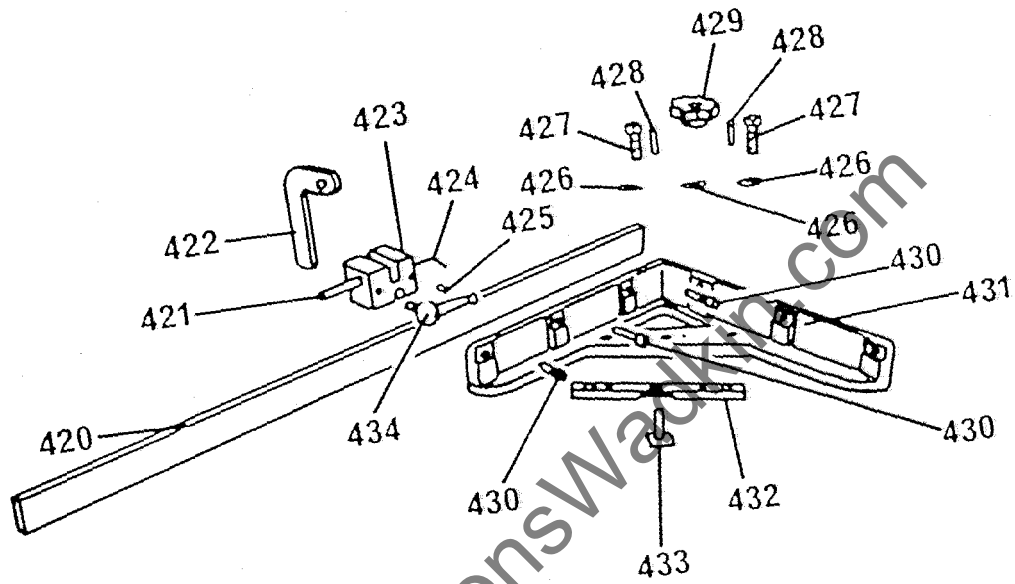

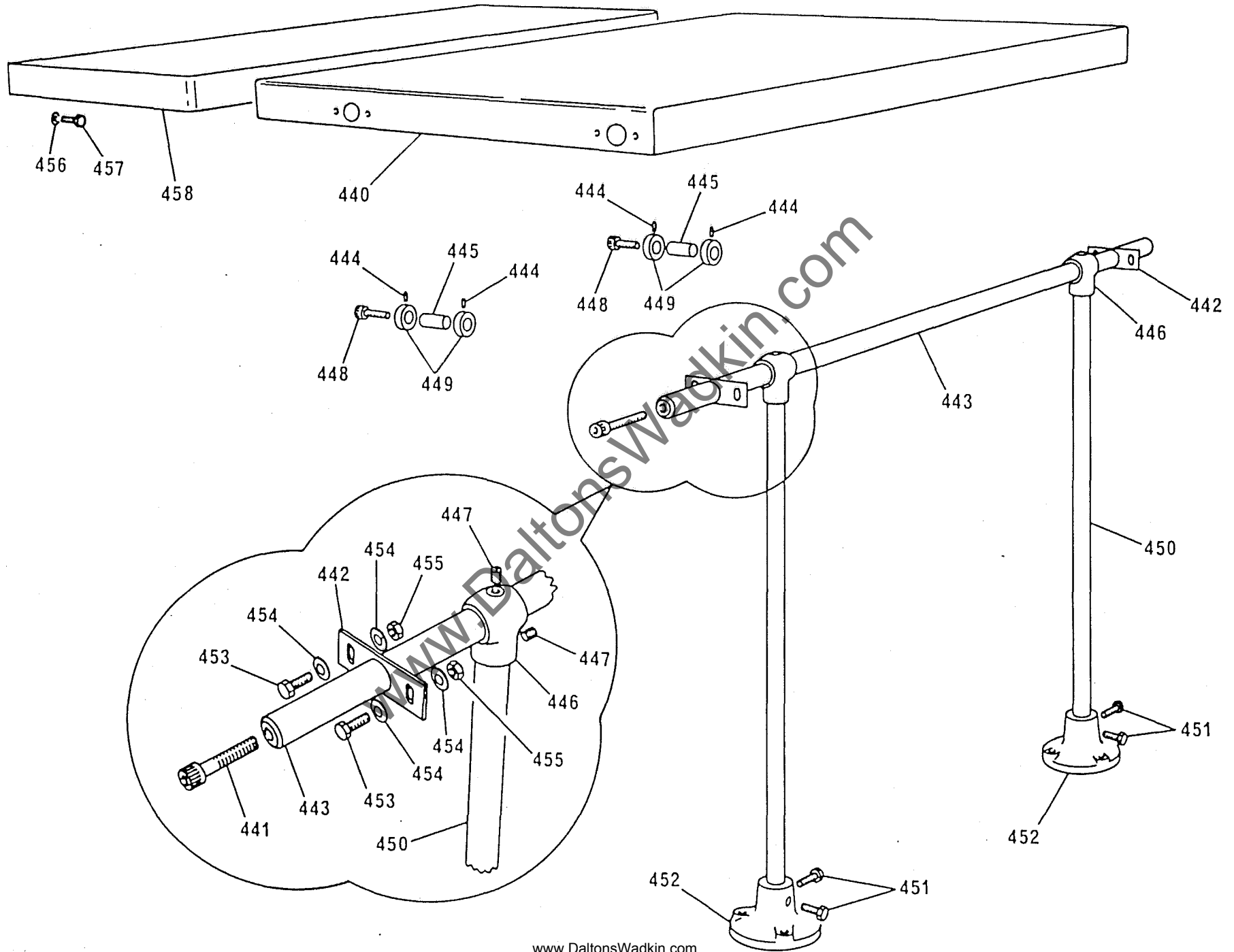

SHEET METAL EXTENSION TABLE ASSEMBLY

<u>Ref.No.</u>	<u>Part No.</u>	<u>No.Off.</u>	<u>Description.</u>
440	D-1030/V/155	1	Extension table.
441		1	M10 x 40mm long socket head cap screw.
442	A-1026/80	2	Extension table adjuster plate.
443	A-1030/162	1	Extension table tie bar.
444		4	M5 x 5mm socket head grubscrew.
445	A-1030/163	2	Extension table end support bar.
446	A-1026M/99	2	Tee filboe for extension table.
447		4	3/8"BSF x 3/8" long socket set screw.
448		2	M10 x 30mm long socket head capscrew.
449	A-1030/164	4	Extension table locking collars.
450	A-1026/84	2	Extension table support leg.
451		4	M10 x 20mm long hexagon head bolt.
452	A-1026M/85	2	Extension table support foot.
453		4	M6 x 12mm long hexagon head bolt.
454		8	6mm washer.
455		4	M6 nut.
456		3	10mm washer.
457		3	M10 x 30mm long hexagon head bolt.
458	C-1030M/5	1	Extension table wing.

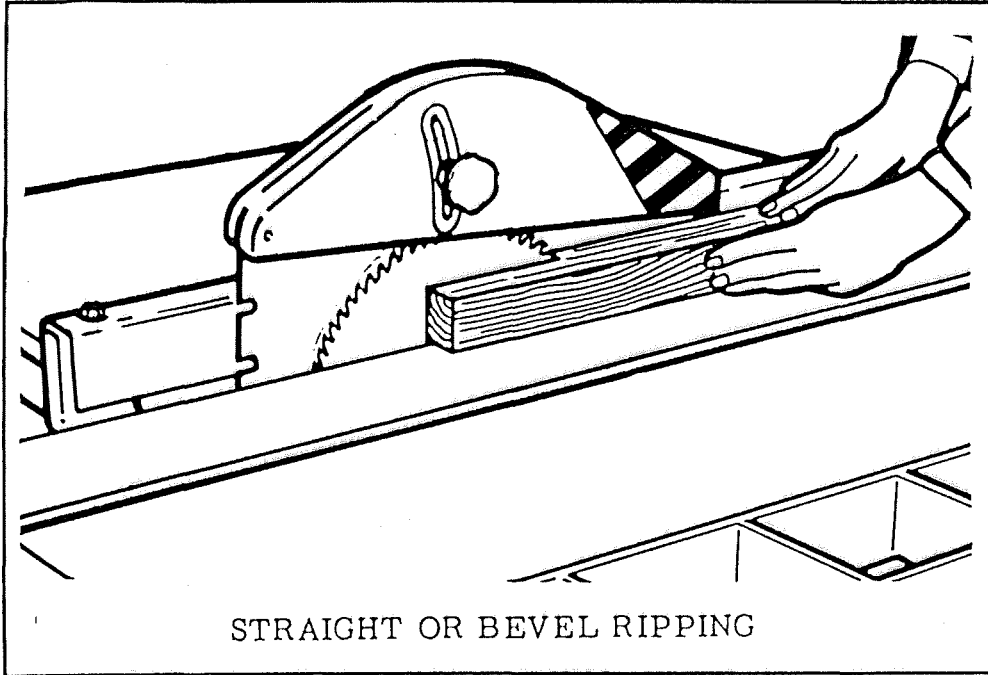

STRAIGHT OR BEVEL RIPPING

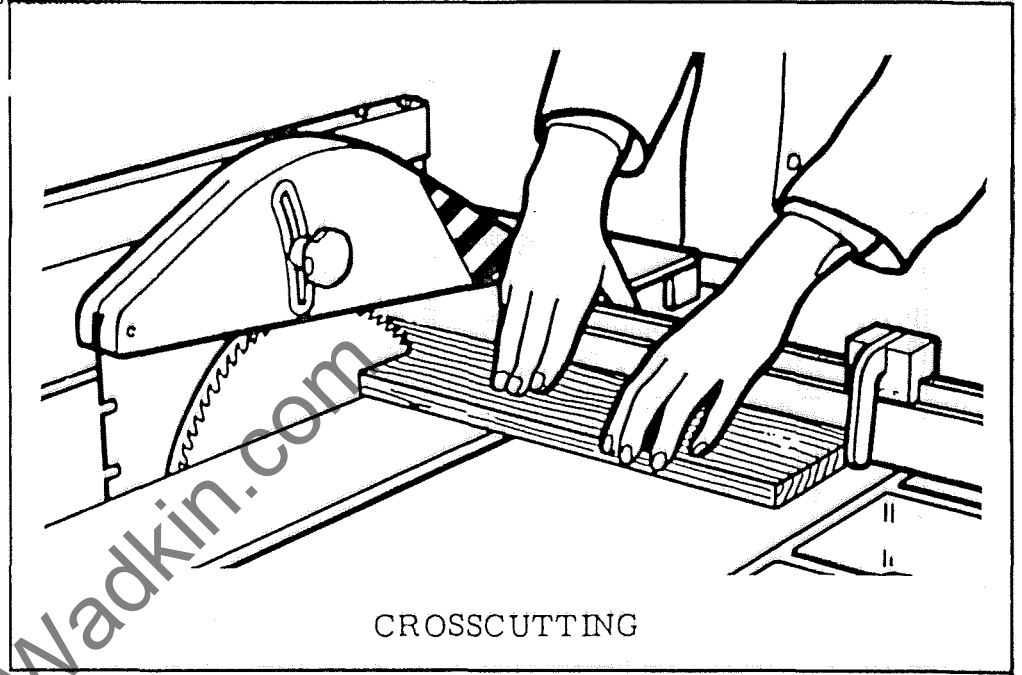

CROSSCUTTING

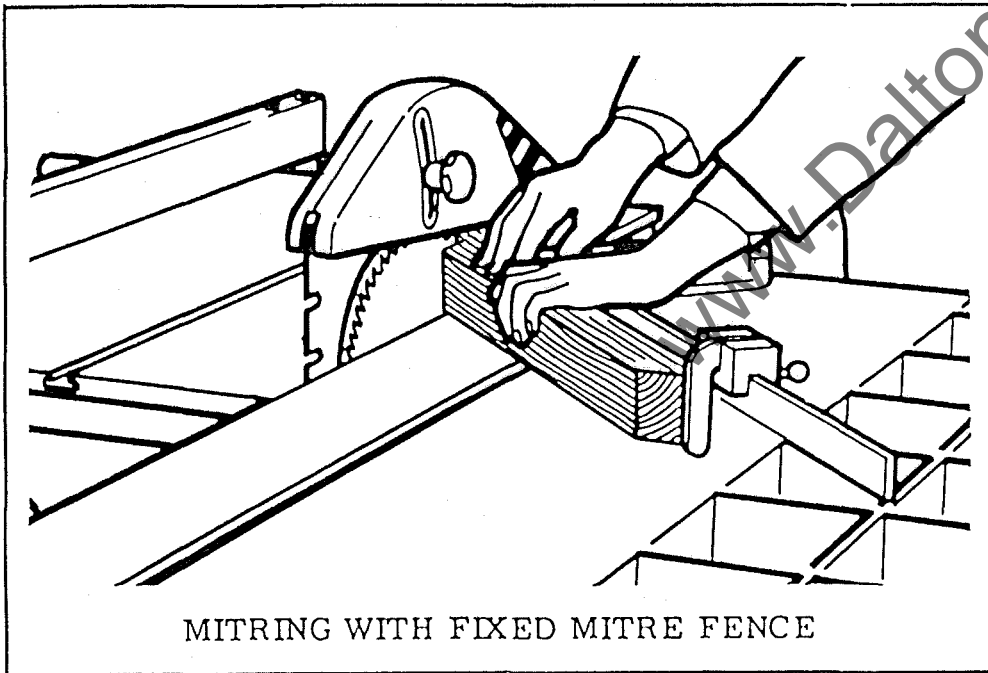

MITRING WITH FIXED MITRE FENCE

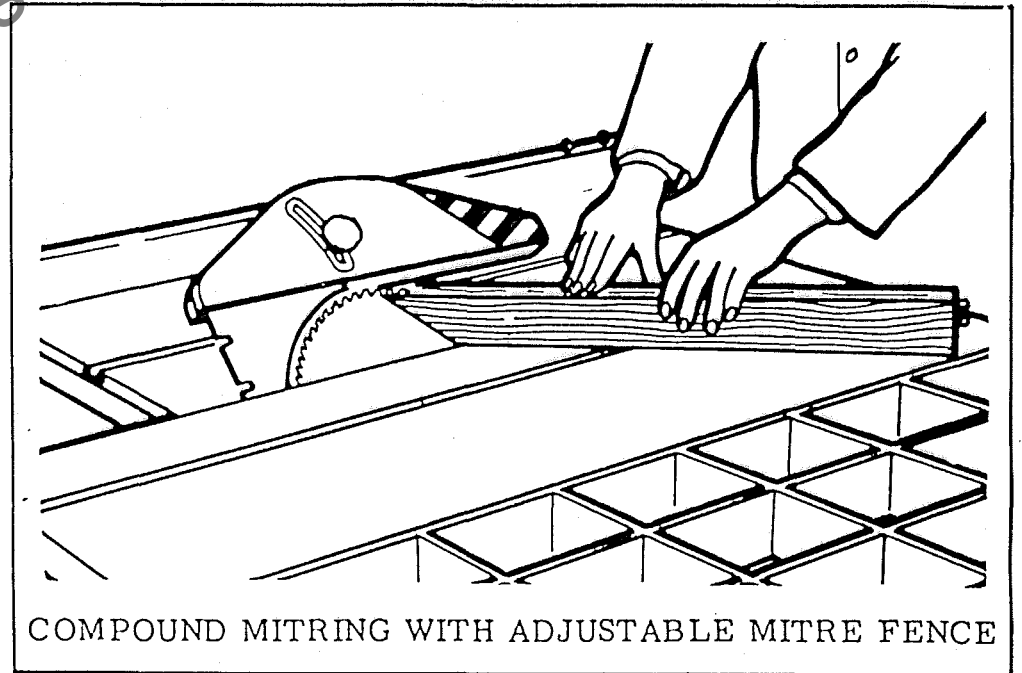

COMPOUND MITRING WITH ADJUSTABLE MITRE FENCE