



---

# Operating instructions F45 EvoDrive

1.1/2015

GB

<b>1</b>	<b>Foreword</b>	<b>5</b>
<b>2</b>	<b>Identification</b>	<b>6</b>
2.1	Machine identification	6
2.2	Certificates	7
2.3	Marks of conformity	16
<b>3</b>	<b>Product description</b>	<b>17</b>
3.1	Marking, pictographs	17
3.2	Intended use	17
3.3	Dimensions and weights	23
3.4	Auxiliary power/power requirements	24
3.5	Emissions	26
3.5.1	Noise - characteristic values	26
3.5.2	Dust	28
3.5.3	Electromagnetic compatibility	28
3.6	Ambient conditions	29
3.7	Safety information	30
3.7.1	Operational safety	30
3.7.2	Safety devices	33
3.7.3	Top safety hood/riving knife	34
3.7.4	Handling batteries / accumulators	35
<b>4</b>	<b>Definitions</b>	<b>37</b>
4.1	Description of machine	37
4.2	Terms	39
<b>5</b>	<b>Transport, siting and installation</b>	<b>42</b>
5.1	Transport	42
5.2	Safety measures before use/installation	43
5.3	Installation	47
5.3.1	Telescopic tube for swinging arm	47
5.3.2	Main table length extension	49

5.3.3	Rip fence	50
5.3.4	Cross-slide and crosscut fence	51
5.3.5	Sliding table	69
5.3.6	Electrical connection	75
5.3.7	Connecting the extraction system (customer side!)	79
5.4	Basic machine setting	80
5.4.1	Sub rollers on the sliding table	80
5.4.2	Main table	82
5.4.3	Swinging arm	83
5.4.4	Cross-slide height	84
5.4.5	Setting free cut	86
5.4.6	Angle cut	88
5.4.7	0° setting of the saw blade	89
<b>6</b>	<b>Operating</b>	<b>90</b>
6.1	Working safely with the dimension saw	90
6.1.1	Cross-slide/crosscut fence	90
6.1.2	Rip fence	93
6.1.3	Double roller carriage	95
6.2	Working examples	97
6.3	Machine operation	105
6.3.1	Main switch	105
6.3.2	Switching the saw drives on and off	106
6.3.3	Setting the speed	108
6.3.4	Fitting the main saw blade	109
6.3.5	Saw blade recommendation	113
6.3.6	Table locking	114
6.4	Monitor controls EvoDrive	115
6.4.1	Height adjustment	117
6.4.2	Tilt adjustment	119
6.4.3	Electromotive rip fence (option)	123
6.4.4	Infinitely variable speed adjustment (option)	126
6.4.5	CNC crosscut fence	128
6.4.6	Vacuum clamping in the sliding table	137
6.4.7	Menu	138
6.5	Protection hood	170
6.6	Optional modules	174
6.6.1	Scorer, tilting to one side	174
6.6.2	Scorer, tilting to both sides	183
6.6.3	Mitre fences	184
6.6.4	DIGIT L dimension display unit	186
6.6.5	Digital angle and length display DIGIT LD	189
6.6.6	Rip fence with DIGIT X digital dimension display	192

6.6.7	Parallel cutting device	196
6.6.8	Workpiece hold-down device	199
6.6.9	Cross-slide width extension	205
6.6.10	Additional cross-slide	206
6.6.11	LASER cutting line display	207
6.6.12	Coolant spray device	209
6.6.13	TIP-SERVO-DRIVE	210
<b>7</b>	<b>Cleaning/care</b>	<b>211</b>
7.1	Safety measures	211
7.2	Maintenance/cleaning by the user	212
7.3	Maintenance/cleaning by qualified persons	223
7.3.1	Checking the winding shield	223
<b>8</b>	<b>Faults/problems/troubleshooting</b>	<b>224</b>
8.1	Machine diagnosis	224
8.2	Motor overload protection	225
8.3	Troubleshooting/faults/messages	226
8.4	Electronic brake module	231
<b>9</b>	<b>Technical data</b>	<b>232</b>
9.1	Standard equipment	232
9.2	Special equipment	236
<b>10</b>	<b>Maintenance and repairs</b>	<b>238</b>
10.1	General	238
10.2	Customer service addresses	239



## 1 Foreword

***Please read these operating instructions carefully before commissioning the machine.***

***No liability will be accepted for any injury, damage or disruption to operations resulting from failure to comply with these operating instructions!***

***Persons operating this sliding table saw must have had sufficient instruction and be suitably qualified!***

***These operating instructions cannot be regarded as a binding type description as the manufacturer may have carried out technical modifications.***

The operating instructions must always be available where the machine is being used. They must be read and heeded by any person performing the following activities at or on the machine:

- Operating including set-up, troubleshooting during operation, elimination of production waste, care, disposal of operating and auxiliary materials
- Maintenance, repair, inspection
- Transport

It is necessary to comply with national regulations on health and safety at work and environmental protection, in addition to the operating instructions.

The removal of safety devices, especially safety hoods for the saw blade cover and riving knives, will endanger the operator and may lead to accidents.

Safe work is only possible with a clean machine and a clean environment!

**Reproduction of this document or parts thereof is only allowed with our permission!**

2 Identification

2 Identification

2.1 Machine identification

The type plate fitted to the machine frame serves for identifying the machine and other important machine data.

Meaning of the stated descriptions:



Fig. 2-1 Type plate

- Type: Machine designation
- Number: Machine specific identification number
- Year of construction: Year of manufacture
- Saw blade min Ø: Diameter of the smallest permissible saw blade
- Saw blade max Ø: Diameter of the largest permissible saw blade
- Guide slot width of the riving knife: Diameter of the guide bolts for the riving knife in the riving knife holding fixture

**2.2 Certificates****Conformity declaration as defined by the machinery directive, Annex II 1A**

-Original / Translation of the original

Manufacturer:	Wilhelm Altendorf GmbH & Co. KG Maschinenbau Wettinerallee 43/45 32429 Minden Germany
Person authorised to compile the technical documentation:	Rolf Tweer, Technology Management, Wilhelm Altendorf GmbH & Co. KG Maschinenbau
Product:	Sliding table saw, type F45
Machine number:	
Authority named for prototype testing according to annex IX:	DGUV Test Prüf- und Zertifizierungsstelle Holz Fachbereich Holz und Metall Vollmoellerstraße 11 70563 Stuttgart Germany Identification number 0392

We hereby declare that the above-mentioned product conforms with all applicable regulations of machinery directive 2006/42/EC. It fulfils the requirements of the following applicable directives:

- Low-voltage directive 2006/95/EC
- EMC directive 2004/108/EC

The following harmonised standards have been applied:

- DIN EN 1870-18:2007:2013, Safety of woodworking machines - Circular sawing machines - Part 18: Dimension saws
- DIN EN ISO 12100 :2011-03 Safety of machinery - General principles for design - Risk assessment and risk reduction
- DIN EN 60204-1:2007:-06, Safety of machinery - Electrical equipment of machines - Part 1: General requirements

Minden, 20/05/2015

---

 Piotr Szablewski, Manager of Development & Construction

## 2 Identification

---

www.DaltonsWadkin.com

### EC prototype testing certificate

Bescheinigung  
Nr. **HO 131059**  
vom **02.07.2015**

**DGVU Test**  
Prüf- und Zertifizierungsstelle  
Holz  
Fachbereich Holz und Metall

Europäisch notifizierte Stelle  
Kenn-Nummer: 0392

### EG-Baumusterprüfbescheinigung

Name und Anschrift des  
Bescheinigungsinhabers:  
(Auftraggeber) Wilhelm Altendorf GmbH & Co. KG Maschinenbau  
Wettinerallee 43/45  
32429 Minden

Produktbezeichnung: **Formatkreissägemaschine**

Typ: F45 ProDrive, F45 EvoDrive, F45 ElmoDrive

Prüfgrundlage: GS-HO-01: 08.2013 Holzbearbeitungsmaschinen

Zugehöriger Prüfbericht: 114114

Weitere Angaben: Bestimmungsgemäße Verwendung:  
Bearbeiten von Holz und gleichartig zu bearbeitenden Werkstoffen.  
Mitgeprüfte Ausstattung: siehe Anlage  
Nachfolgebescheinigung zu Nr. HO 131059 vom 30.09.2013.

Das geprüfte Baumuster entspricht den einschlägigen Bestimmungen der Richtlinie 2006/42/EG (**Maschinen**).  
Diese Bescheinigung ist gültig bis: **10.03.2016**  
Weiteres über die Gültigkeit, eine Gültigkeitsverlängerung und andere Bedingungen regelt die Prüf- und Zertifizierungsordnung.



PZB02  
11.14 Deutsche Gesetzliche Unfallversicherung (DGUV) e.V.  
Spitzenverband der gewerblichen Berufsgenossenschaften  
und der Unfallversicherungsträger der öffentlichen Hand

DGVU Test Prüf- und Zertifizierungsstelle Holz  
Fachbereich Holz und Metall  
Vollmoellerstraße 11 • 70563 Stuttgart • Deutschland

## 2 Identification



Anlage zu EG-Baumusterprüfbescheinigung Nr. HO 131059, Ausstellungsdatum 02.07.2015

Sicherheitsrelevante Ausstattung, die in mindestens einem der Typen ProDrive, EvoDrive und ElmoDrive enthalten ist
Bildschirmsteuerung mit 12" Touchscreen
Doppelrollwagenlänge 2.250 / 3.000 / 3.200 / 3.400 / 3.800 / 4.300 / 5.000 mm
TIP-SERVO-DRIVE (kraftbetriebener Doppelrollwagen)
Start-Stop-Taster am Doppelrollwagen
Antrieb der Hauptsäge über Frequenzumrichter
Hauptsägeblattdurchmesser max. 550 mm
Verstärkter Antriebsmotor für die Hauptsäge 7,5 kW bzw. 11 kW
Vorritzsäge mit kraftbetriebener Verstellung
Vorritzaggregat Typ Rapido Plus, Höhen-, Seiten- und Schnittbreitenverstellung kraftbetrieben
Kraftbetriebener Parallelanschlag
Winkelgehrungsanschlag mit Längenmesssystem
Parallelogramm-Querschlitzen
Einseitiger Gehrungsanschlag
Duplex-Gehrungsanschlag
Digitalanzeige für den Parallelanschlag
Kraftbetriebener Gehrungsanschlag
Tischverlängerungen, 1.200 / 1.600 / 2.000 mm
Querschlitzenverbreiterung
Zusätzlicher Querschlitzen mit Bodenstützrolle
Schwenkbarer Vordertisch; nicht in Verbindung mit kraftbetriebenem Parallelanschlag
2. Auflage am Doppelrollwagen
Schnellspanner, manuell
Schnellspanner, elektro-pneumatisch
Vakuumspanneinheiten im Doppelrollwagen; nicht in Verbindung mit TIP-SERVO-DRIVE
Druckbalken, pneumatisch
Parallelschneidvorrichtung
Laser-Richtlicht zur Schnittfugenanzeige
Sprühvorrichtung
Drehstromsteckdose am Maschinenständer, z.B. für Absaugung, Vorschubapparat

Stuttgart, 02.07.2015

*F. Hagen*  
 Leiter der Prüf- und Zertifizierungsstelle  
 Frank-Hagendorf





## GS test certificate

Bescheinigung  
Nr. **HO 131060**  
vom 02.07.2015

 **DGVU Test**  
Prüf- und Zertifizierungsstelle  
Holz  
Fachbereich Holz und Metall

## GS - Zertifikat

Name und Anschrift des  
Bescheinigungsinhabers:  
(Auftraggeber) Wilhelm Altendorf GmbH & Co. KG Maschinenbau  
Wettinerallee 43/45  
32429 Minden

Produktbezeichnung: **Formatkreissägemaschine**

Typ: F45 ProDrive, F45 EvoDrive, F45 ElmoDrive

Prüfgrundlage: GS-HO-01: 08.2013 Holzbearbeitungsmaschinen

Zugehöriger Prüfbericht: 114114

Weitere Angaben: Bestimmungsgemäße Verwendung:  
Bearbeiten von Holz und gleichartig zu bearbeitenden Werkstoffen.  
Mitgeprüfte Ausstattung: siehe Anlage  
Nachfolgebescheinigung zu Nr. HO 131060 vom 30.09.2013.

Das geprüfte Baumuster stimmt mit den in § 21 Absatz 1 des Produktsicherheitsgesetzes genannten Anforderungen überein. Der Bescheinigungsinhaber ist berechtigt, das umseitig abgebildete GS-Zeichen an den mit dem geprüften Baumuster übereinstimmenden Produkten anzubringen. Der Bescheinigungsinhaber hat dabei die umseitig aufgeführten Bedingungen zu beachten.

Diese Bescheinigung einschließlich der Berechtigung zur Anbringung des GS-Zeichens ist gültig bis: **10.03.2016**

Weiteres über die Gültigkeit, eine Gültigkeitsverlängerung und andere Bedingungen regelt die Prüf- und Zertifizierungsordnung.



## 2 Identification



Anlage zu GS - Zertifikat Nr. HO 131060, Ausstellungsdatum 02.07.2015

<b>Sicherheitsrelevante Ausstattung, die in mindestens einem der Typen ProDrive, EvoDrive und ElmoDrive enthalten ist</b>
Bildschirmsteuerung mit 12" Touchscreen
Doppelrollwagenlänge 2.250 / 3.000 / 3.200 / 3.400 / 3.800 / 4.300 / 5.000 mm
TIP-SERVO-DRIVE (kraftbetriebener Doppelrollwagen)
Start-Stop-Taster am Doppelrollwagen
Antrieb der Hauptsäge über Frequenzumrichter
Hauptsägeblattdurchmesser max. 550 mm
Verstärkter Antriebsmotor für die Hauptsäge 7,5 kW bzw. 11 kW
Vorritzsäge mit kraftbetriebener Verstellung
Vorritzaggregat Typ Rapido Plus, Höhen-, Seiten- und Schnittbreitenverstellung kraftbetrieben
Kraftbetriebener Parallelanschlag
Winkelgehungsanschlag mit Längenmesssystem
Parallelogramm-Querschlitzen
Einseitiger Gehrungsanschlag
Duplex-Gehrungsanschlag
Digitalanzeige für den Parallelanschlag
Kraftbetriebener Gehrungsanschlag
Tischverlängerungen 1.200 / 1.600 / 2.000 mm
Querschlitzenverbreiterung
Zusätzlicher Querschlitzen mit Bodenstützrolle
Schwenkbarer Vordertisch; nicht in Verbindung mit kraftbetriebenem Parallelanschlag
2. Auflage am Doppelrollwagen
Schnellspanner, manuell
Schnellspanner, elektro-pneumatisch
Vakuumspanneinheiten im Doppelrollwagen; nicht in Verbindung mit TIP-SERVO-DRIVE
Druckbalken, pneumatisch
Parallelschneidvorrichtung
Laser-Richtlicht zur Schnittfugenanzeige
Sprühvorrichtung
Drehstromsteckdose am Maschinenständer, z.B. für Absaugung, Vorschubapparat

Stuttgart, 02.07.2015

*Frank Hagendorff*  
 Leiter der Prüf- und Zertifizierungsstelle  
 Frank Hagendorff





## DGUV Test Certificate

Bescheinigung Nr. <b>HO 111007</b> vom <b>02.07.2015</b>
--



## DGUV Test - Zertifikat

Name und Anschrift des Bescheinigungsinhabers: (Auftraggeber) Wilhelm Altendorf GmbH & Co. KG Maschinenbau Wettinerallee 43/45 32429 Minden

Produktbezeichnung: **Formatkreissägemaschine**

Typ: F45 ProDrive, F45 EvoDrive, F45 ElmoDrive

Prüfgrundlage: GS-HO-05: 08.2013 Staubemission von Holzbearbeitungsmaschinen

Zugehöriger Prüfbericht: 114114

Weitere Angaben: Bestimmungsgemäße Verwendung: Bearbeiten von Holz und gleichartig zu bearbeitenden Werkstoffen  
Hinweis: Holzstaubgeprüft im Sinne von BGI 739-1. Dem DGUV Test-Zeichen muss der Vermerk „holzstaubgeprüft“ angefügt werden.  
Mitgeprüfte Ausstattung: siehe Anlage  
Nachfolgebescheinigung zu Nr. HO 111007 vom 30.09.2013.

Das geprüfte Baumuster entspricht der oben angegebenen Prüfgrundlage. Der Bescheinigungsinhaber ist berechtigt, das umseitig abgebildete DGUV Test-Zeichen an den mit dem geprüften Baumuster übereinstimmenden Produkten sofern zutreffend mit dem oben genannten Zeichenzusatz anzubringen. Diese Bescheinigung einschließlich der Berechtigung zur Anbringung des DGUV Test-Zeichens ist gültig bis: **10.03.2016**

Weiteres über die Gültigkeit, eine Gültigkeitsverlängerung und andere Bedingungen regelt die Prüf- und Zertifizierungsordnung.



## 2 Identification



Anlage zu DGUV Test - Zertifikat Nr. HO 111007, Ausstellungsdatum 02.07.2015

Sicherheitsrelevante Ausstattung, die in mindestens einem der Typen ProDrive, EvoDrive und ElmoDrive enthalten ist
Bildschirmsteuerung mit 12" Touchscreen
Doppelrollwagenlänge 2.250 / 3.000 / 3.200 / 3.400 / 3.800 / 4.300 / 5.000 mm
TIP-SERVO-DRIVE (kraftbetriebener Doppelrollwagen)
Start-Stop-Taster am Doppelrollwagen
Antrieb der Hauptsäge über Frequenzumrichter
Hauptsägeblattdurchmesser max. 550 mm
Verstärkter Antriebsmotor für die Hauptsäge 7,5 kW bzw. 11 kW
Vorritzsäge mit kraftbetriebener Verstellung
Vorritzaggregat Typ Rapido Plus, Höhen-, Seiten- und Schnittbreitenverstellung kraftbetrieben
Kraftbetriebener Parallelanschlag
Winkelgehrungsanschlag mit Längenmesssystem
Parallelogramm-Querschlitzen
Einseitiger Gehrungsanschlag
Duplex-Gehrungsanschlag
Digitalanzeige für den Parallelanschlag
Kraftbetriebener Gehrungsanschlag
Tischverlängerungen, 1.200 / 1.600 / 2.000 mm
Querschlitzenverbreiterung
Zusätzlicher Querschlitzen mit Bodenstützrolle
Schwenkbarer Vordertisch; nicht in Verbindung mit kraftbetriebenem Parallelanschlag
2. Auflage am Doppelrollwagen
Schnellspanner, manuell
Schnellspanner, elektro-pneumatisch
Vakuumspanneinheiten im Doppelrollwagen; nicht in Verbindung mit TIP-SERVO-DRIVE
Druckbalken, pneumatisch
Parallelschneidvorrichtung
Laser-Richtlicht zur Schnittfugenanzeige
Sprühvorrichtung
Drehstromsteckdose am Maschinenständer, z.B. für Absaugung, Vorschubapparat

Stuttgart, 02.07.2015

*F. Hagendorf*  
 Leiter der Prüf- und Zertifizierungsstelle  
 Frank Hagendorf









C US-Certificate

<h1>Certificate</h1>		
Certificate no.		CU 72071841 01
<b>License Holder:</b> Wilhelm Altendorf GmbH & Co. KG Wettiner Allee 43-45 D-32429 Minden Germany	<b>Manufacturing Plant:</b> Wilhelm Altendorf GmbH & Co. KG Wettiner Allee 43-45 D-32429 Minden Germany	
<b>Test report no.:</b> USA-UH 30771975 001	<b>Client Reference:</b> Rolf Tweer	
<b>Tested to:</b> UL 987:1996 R9.00 C22.2 No. 73-1953 (R2004) C22.2 No. 105-1953 (R2004)		
<b>Certified Product:</b> Table Saw Stationary	<b>License Fee - Units</b>	
Model Designation: F45/Mod.2006	7	
Rated Voltage: AC 380-440V, 60Hz		
Rated Current: 10.5/12A		
Rated Power: 5.5kW		
Appendix: 1, 1-2	7	
<b>Licensed Test mark:</b> 	<b>Signatures</b>  Stephan Schmitt President	<b>Date of Issue (day/mo/yr)</b> 26/07/2007  Dipl.-Ing. M. Raap QA Certification Officer
TUV Rheinland of North America, Inc., 12 Commerce Road, Newtown, CT 06470, Tel (203) 426-9880 Fax (203) 426-4099		

2 Identification

2.3 Marks of conformity

			
<p>CE symbol</p>	<p>GS symbol</p>	<p>Wood dust approved mark</p>	<p>C US mark</p>

### 3 Product description

#### 3.1 Marking, pictographs

		
Danger warning	Hand injury warning	Laser beam warning
		
Crushing risk warning	Voltage warning	Note: Wear ear protection

#### 3.2 Intended use

The sliding table saw and the workpiece guide equipment supplied with it are intended to be used for cutting wood and similar materials such as:

- Laminated and unlaminated board materials (e.g. chipboard, coreboard, MDF board, ...)
- Solid wood
- Veneer with a suitable clamping device
- Gypsum plasterboard
- Cardboard
- Dimensionally stable plastics (thermoset plastics, thermoplastics). Sawing these materials does not normally involve any risks in respect of dust, chips, and thermal degradation products.
- Aluminium and aluminium alloys

### 3 Product description

---

The sliding table saw and the workpiece guide equipment supplied with it are **not intended** to be used for cutting materials such as:

- Sheet steel
- Sheet brass
- Sheet copper
- Round wood without the use of a suitable clamping device

#### **Tools:**

- The chosen saw blade must be suitable both for the specific work cycle (e.g. longitudinal cutting or crosscutting) and for the specific material.
- Only circular blades which are solid chrome vanadium (CV) or tungsten carbide tipped (TCT) and have a maximum width of 20 mm are permitted for the main saw and milling/grooving cutter. The middle table strip and the cushioning disc must be removed when using a milling/grooving cutter.
- Saw blades with a maximum diameter of 120 mm are allowed for the scoring saw.
- **Saw blades made of high-alloy high-speed steel (HSS) may not be used.**
- **Wobble units may not be used.**



Usable saw blades:

250 - max. 500 mm diameter with scorer

250 - max. 550 mm diameter without scorer

**Site of installation/use:**

- The machine is not suitable for use outdoors or in rooms that are subject to moisture or the risk of explosions.
- The intended use of the machine involves connection to a suitably dimensioned extraction system.
- Intended use also involves compliance with ALTENDORF's specified operating, maintenance and repair conditions and adherence to the safety information contained in the operating instructions.
- The sliding table saw may only be used, set up and maintained by persons who are familiar with the machine and aware of the dangers.
- The pertinent accident prevention regulations as well as any other generally recognised technical safety and industrial medicine rules must be observed.
- Repair work must be carried out by our own customer service or by an organisation that we have authorised. Only original ALTENDORF spare parts may be used for this. ALTENDORF will assume no warranty for any damage that is caused by using non-original spare parts.

**Coolant spray device:** (Option)

It is advisable to use a coolant spray device when sawing aluminium and plastics. When using such a spray device, make sure you only use coolant that does not impair the function of safety-relevant parts such as protection hoods! (The transparent parts of the protection hood are made of polycarbonate, and the grey hood support of polyamide.)

**Clamping device:**

A suitable clamping device should be used for small workpieces, in particular.

### 3 Product description

#### Machine operator positions:

The sliding table saw is intended to be operated from the following operator positions:

1. On the left of the sliding table at the front of the machine, seen in the feed direction (main operator position).
2. At the front cross-end of the machine on the right of the sliding table when working with the rip fence (make sure you do not move your body or parts of it into the blade rotation area).
3. Any person removing the workpieces must stand at the rear cross-end of the machine behind the main table length extension (under no circumstances in the sliding table traverse area)!

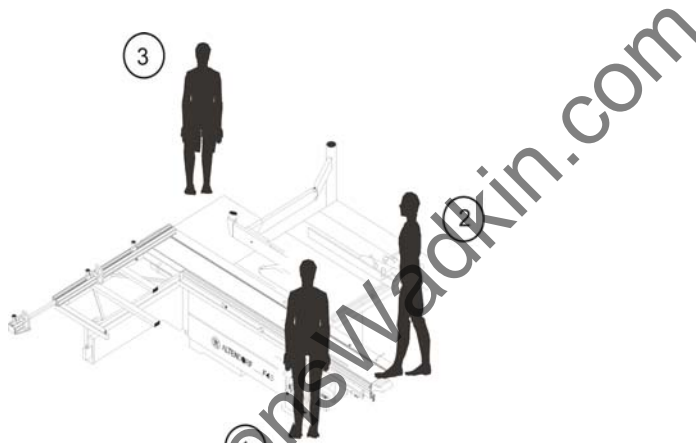

Fig. 3-1 Machine operator positions



#### Warning!

When removing workpieces at the rear of the machine, ensure that you keep sufficient distance from the extending telescopic tube.

Non-adherence may lead to knee injuries!



#### Note!

Any other use is deemed as unintended. ALTENDORF will not be liable for any kind of injury or damage that may result from such unintended use; the risk thereof is borne by the user alone.

Unauthorised modifications by users to the machine or its electrical parts and the use of non-original parts on the machine exclude any liability by the manufacturer for any resultant injury or damage.



**Foreseeable misuse:**

- Working with the safety hood swung up
- Working with the safety hood swung away
- Failure to use the push stick or push block for cuts < 120 mm
- Moving the sliding table without using the handle
- Trimming without the trimming shoe
- Touching or manual infeed with automatically moving stops
- Saws without a riving knife
- Incorrect setting of the straight edge on the rip fence



**Warning!**

Always, under all circumstances avoid the above-mentioned types of work.

All types of foreseeable misuse can lead to severe injuries!

---

www.DaltonsWadkin.com

### 3 Product description

---

#### Residual risk:

Even when the machine is operated in accordance with its intended use and all pertinent safety regulations, the following residual risks may be encountered because of design changes caused by the intended use in question:

- Contact with the main saw blade and the scoring blade in the cutting area, in particular when the saw blade is tilted in the  $-45^\circ$  position and the protection hood is not correctly adjusted.
- Contact with the main saw blade and the scoring blade from beneath the table level when the sliding table is pushed fully forward or pulled fully back.
- Kick-back of workpiece or workpiece parts.
- Individual teeth spinning off tungsten carbide tipped blades.
- Breakage and ejection of the saw blade.
- Crushing at the manual or motor-driven sliding table.
- Crushing between the motor-driven tilt movement of the saw blade and the rip fence or workpieces lying in the tilting area.
- Contact with live parts when the electrical installation area is open.
- Damage to hearing as a result of working for long periods of time without hearing protection
- Emission of health-endangering dust from operation without extraction.
- Wear suitable gloves due to the risk of cuts when handling saw blades, grooving tools and when pushing the wood into the machine, as well as during maintenance work
- Do not remove chips while the saw blades are turning
- Do not use the machine before all protective devices/guards required for processing have been installed and are in perfect condition



---

#### Warning!

Avoid the potential dangers posed by these remaining risks by paying increased attention when setting up, operating and servicing the machine!

Always adhere to the specified working positions when operating the machine.

---

### 3.3 Dimensions and weights

Sliding table length	Net weight, machine box	Gross weight, machine box	Net weight, sliding table	Gross weight, sliding table	Net weight, accessories	Gross weight, accessories	Dimensions, machine box	Dimensions, sliding table box
[mm]	[kg]	[kg]	[kg]	[kg]	[kg]	[kg]	[mm]	[mm]
2250	855-1282	970-1495	114	175	131-142	203-230	2580x660x330	2060x960x500
3000	855-1282	970-1495	158	234	131-142	203-230	3330x660x330	2060x960x500
3200	855-1282	970-1495	170	250	131-142	203-230	3530x660x330	2060x960x500
3400	855-1282	970-1495	205	289	131-142	203-230	3730x660x330	2060x960x500
3800	855-1282	970-1495	212	304	131-142	203-230	4130x660x330	2060x960x500
4300	855-1282	970-1495	249	350	131-142	203-230	4630x660x330	2060x960x500
5000	855-1282	970-1495	269	385	131-142	203-230	5330x660x330	2060x960x500

*The weights depend on the machine equipment!*

### 3 Product description

#### 3.4 Auxiliary power/power requirements

The permissible tolerance of the specified mainsvoltage is + 5 % and - 10 %. Greater deviations will impair functionality.

Only connect the machine to a three-phase AC mains with phases L1, L2 and L3, otherwise the brake module or the frequency converter may be destroyed. Operating the machine together with phase converters, frequency converters or transformer-capacitor combinations will destroy the brake module or the frequency converter and power supply unit!

Screw-in fuse links of the type NEOZED D02 (utilisation category gL) should preferably be used as back-up fuses.

The supply line must be dimensioned such that it cannot be overloaded and a max. voltage drop < 3% occurs at nominal current.

The loop impedance and suitability of the overcurrent protection device must be inspected/tested at the machine installation site.

#### Note!



**Devices for differential protection** (to be provided by the customer!)

In 230V/400V systems, devices are generally used that detect leakage currents < 300 mA. For switch-off in the event of a fault, RCDs (residual current devices) with a rated differential current < 300 mA are normally used, and for indication, fault current indicators (relays) or RCMs (residual current monitors) are used.

Mains voltage independent devices for differential protection that also detect differential currents (leakage currents) with DC components are to be used.

If leakage current indicators or RCMs are used, ensure that additional switch-off devices, e.g. circuit breakers, are provided.

(Extract from VDS Directive 2033)

If there are special safety requirements for persons setting up the equipment, then frequency converters complying with EN 50178 must be replaced by RCMA's with an isolator (preferably) or by type-B RCDs (universal-current-sensitive residual-current circuit breakers).

The following devices can be used:

Manufacturer: Doepke switching devices; these switching devices can also be purchased via Altendorf.

- DFS4 040-4/0,30-B NK, release current 300 mA
- DFS4 040-4/0,03-B NK, for personal protection

### Auxiliary power/power requirements

Motor [kW]	Voltage [V]	Frequency [Hz]	Nominal current Without/with scoring blade [A]	Fusing [A]
4	230	50	12.4 / 15.8	25
4	400	50	7.2 / 8.7	20
5.5	200 - 220	50	19.8 / 23.2	35
7.5	200 - 220	50	26.5 / 29.9	35
5.5	380 - 420	50/60	11.5 / 13.5	20
7.5	380 - 420	50	15.5 / 17.5	25
11	380 - 420	50	22.5 / 24.5	35
VARIO tilting to one side	380 - 420	50/60	36.0 / 38.0	35
VARIO 5kW tilting to both sides	380-420	50/60	36.0 / 38.0	35
VARIO 6.5kW tilting to both sides	380-420	50/60	36.0/38.30	35
5.5	200 - 220	60	20.0 / 23.5	35
7.5	200 - 220	60	24.0 / 28.0	35
5.5	600	60	7.5 / 8.5	20
7.5	600	60	9.5 / 10.5	20

### 3 Product description

## 3.5 Emissions

### 3.5.1 Noise - characteristic values

Sound power level [dB (A)]	Emission sound level at the workplace [dB (A)]	Tools
Idling_____L <sub>WA</sub> = 87.3 Cutting__L <sub>WA</sub> = 96.6	Idling_____L <sub>PA</sub> =77.4 Cutting__L <sub>PA</sub> = 84.0	Circular saw blade 300x3.2/96 WZ n = 3987 rpm
Idling_____L <sub>WA</sub> = 101.3 Cutting__L <sub>WA</sub> = 104.2	Idling_____L <sub>PA</sub> =95.7 Cutting__L <sub>PA</sub> = 92.1	Circular saw blade 350x3.5/54 WZ n = 3987 rpm
Idling_____L <sub>WA</sub> = 93.9 Cutting__L <sub>WA</sub> = 98.7	Idling_____L <sub>PA</sub> =84.1 Cutting__L <sub>PA</sub> = 89.9	Circular saw blade 350x3.5/84 WZ n = 3987 rpm
Idling_____L <sub>WA</sub> = 93.9 Cutting__L <sub>WA</sub> = 99.1	Idling_____L <sub>PA</sub> =84.5 Cutting__L <sub>PA</sub> = 86.0	Circular saw blade 303x3.2/60 DH n = 3987 rpm <b>LOW NOISE</b>
Idling_____L <sub>WA</sub> = 87.7 Cutting__L <sub>WA</sub> = 96.3	Idling_____L <sub>PA</sub> =78.1 Cutting__L = 84.6	Circular saw blade 303x3.2/90 WZ n = 3987 rpm <b>LOW NOISE</b>

The noise emission values determined according to DIN EN ISO 3746 for the sound power level or DIN EN ISO 11202 and for the sound pressure level at the workplace on the basis of the working conditions stated in ISO 7960 Appendix A are as listed in the table.

A measurement uncertainty allowance of K = 4 dB (A) applies to the stated emission values.

The stated values are emission levels and therefore not necessarily levels for safe working. Although there is a correlation between emission and immission levels, it cannot be reliably deduced from this whether or not additional precautionary measures are needed to protect operators.

Factors that influence the immission level at the workplace include the duration of exposure, room characteristics, other sources of noise such as the type and number of neighbouring machines, and other working processes involving noise emission.

www.DaltonsWadkin.com

### 3 Product description

---

#### 3.5.2 Dust

The dust emission values – measured in accordance with the “Principles for Testing Dust Emission (Concentration Parameters) from Woodworking Machines” issued by the German trade association's technical committee for wood – are below 2 mg/m<sup>3</sup>.

When the machine is attached to a correctly functioning extraction system with an air speed of at least 20 m/s (measured after the join of the two extraction connections) you can assume it is and will stay compliant with the technical reference concentration (TRK) limit for wood dust that is in force in Germany.

The machines are tested concerning wood dust in accordance with the BGI 739-1. The machines bear the DGUV mark with the additional wood dust mark "holzstaubgeprüft". Consequently, a company operating the machine in Germany is exempt from the obligation to perform measurements at the workplace in accordance with TRGS 553.

#### 3.5.3 Electromagnetic compatibility

EMC (Electromagnetic Compatibility) is the ability of an electrical device to function in its electromagnetic environment without disruptively influencing this environment, which also includes other devices, or being disturbed by it.

The machine complies with the requirements set out in the European electromagnetic compatibility directive 2004/108/EC (EMC directive).



### 3.6 Ambient conditions

#### Transport and storage

The machine must not be used in an environment with explosive or corrosive gases.

The ambient temperatures for transport and storage range from - 25° C to + 55° C, and + 70° C is permissible for a short time.

The maximum air humidity must not exceed 90%, and condensation must be avoided in all cases.

www.DaltonsWadkin.com

### 3 Product description

## 3.7 Safety information

### 3.7.1 Operational safety

The operation of woodworking machines with manual feed involves a high risk in the event of incorrect handling. Therefore always observe the safety information that is summarised in this chapter as well as government and other industrial safety regulations (e.g. accident prevention regulations)!

#### Note!



Ensure that the operators are suitably trained in the use, setting and operation of the machine!

- Never operate the machine without the protective devices intended for the specific work cycle (also refer to “Working safely with the sliding table saw – working examples”), and do not make any changes that could impair safety.
- Before all work, make sure that the protective and working devices are securely fitted and are not damaged.
- Before changing a tool, rectifying any faults and carrying out repairs, make sure that the machine cannot be turned on accidentally, for example by padlocking the main switch.
- Only use correctly sharpened tools designed to conform with the requirements of the European standard EN 847-1:2005+A1:2007.
- When grooving with milling tools, only use milling tools for manual feeding with a groove width less than or equal to 20 mm (5 mm for machines with the option "Saw blade tilting to both sides"), marked with MAN according to the European standard EN 847-1:2005+A1:2007.
- Only fit saw blades with the dimensions described in the technical data. The diameter of the mounting hole must always measure 30 mm. Loose intermediate rings are not allowed to be used.
- Select the rotational speed so that the maximum permissible rotational speed specified for the tool is not exceeded when using tungsten carbide tipped saw blades or grooving cutters.
- HSS saw blades and cracked or deformed saw blades may not be used.
- Always wear tight-fitting work clothes and do not wear rings, bracelets or watches.
- Make sure that the workplace is uncluttered, slip-proof and well lit.
- Do not cut workpieces that are too large or too small for the machine to handle.
- When working at the machine, always stand to the side of the saw blade outside a possible kick-back area.

- Remove any loose parts from the vicinity of the saw blade before switching on the machine.
- Only start cutting when the saw blade has reached its full rotational speed.
- Always use the top protection hood!
- Adjust the height of the top protection hood to the thickness of the workpiece to be cut. When operating with a tilted saw blade, exchange the narrow hood for a wide hood. For machines with the option "Saw blade tilting to both sides", move the protective hood to the respective work position by pushing it to the correct side!
- Always guide the workpiece safely and use the appropriate stops/fences.
- Use a push stick when cutting narrow workpieces (< 120 mm) at the rip fence.
- Crosscuts and longitudinal cuts in round wood are not permitted with the standard feeding aids or fences/stops.
- Always use the riving knife except for insert cuts. The riving knife must not be thicker than the cutting line width or thinner than the main blade. Adjust it so that it is at a distance of least 3 mm and at most 8 mm from the gear rim. The guide slot must be 13 + 0.5 mm wide. The riving knives supplied with the machine cover the entire range of diameters for the saw blades that are allowed to be used – from 250 mm to 550 mm. With respect to their thickness, they match the cutting line widths of commercially available tungsten carbide tipped saw blades. If other saw blades, e.g. made of chrome vanadium (CV), are used, select a riving knife thickness that lies between the cutting line width and the main blade thickness. Such riving knives can be obtained from the trade or directly from ALTENDORF.
- Use an anti-kick device for insert cuts, e.g. the front of the clamping shoe. Fix this in the sliding table groove, ensuring that the sliding table is locked with its interlock to prevent movement. Following insert cutting, refit the riving knife and the top protection hood immediately.
- Only do angle cuts when the cross-slide is fixed to the sliding table. Make sure that small cut-off workpieces cannot be taken up by the gear rim and kick out, for example by using a deflection wedge.
- For trimming, use the clamping shoe fixed to the sliding table to hold down the workpiece.
- When using a feeding unit, use at least the riving knife as an anti-kick device.
- Replace worn-out table strips immediately.
- Wobble units or wobble cutting devices are not allowed to be used.
- The sound pressure level at the workplace generally exceeds 85 dB(A). For this reason, wear hearing protection when working.
- Only qualified electricians are permitted to work on the electrical equipment of the machine.

### 3 Product description

- Regular cleaning of the machine and, in particular, the main table, sliding table and guides (e.g. rip fence) is an important safety factor. Before starting this work, make sure that the machine cannot be switched on unintentionally.
- The sawdust generated during cutting not only impairs visibility but is partially also hazardous to health. Therefore, the machine must be connected to a chip extraction system with both extraction sockets. The minimum air speed at the lower extraction socket must be at least 20 m/s. When the machine is switched on, the extraction system must switch on at the same time.



#### Warning!

Always use a deflector wedge fastened to the table top when small waste pieces are produced during cutting that could be kicked out by the saw blade.



Fig. 3-2 Deflector wedge

### 3.7.2 Safety devices

Altendorf's sliding table saws have been developed in compliance with European standard DIN EN 1870-1 "Safety of woodworking machines – circular sawing machines –: circular saw benches (with and without sliding table) and dimension saws".

During the design stages great importance was attached to creating optimum working conditions, ranging from numerous mechanical and electrical safety devices to noise insulation and reduction of dust emission.

The machine is equipped with all the necessary safety devices to protect against operating risks that could not be eliminated by its design. These safety devices include, in particular:

- Rip fence with straight edge adjustable in cutting direction: Can be pulled back to prevent parts of crosscut workpieces from jamming between the fence and the rising gear rim, or can be switched over to a low guide surface for cutting narrow and flat workpieces, allowing adequate space for the guide hand together with the possibility of lowering the top safety hood onto the workpiece here, too.
- Trimming hold-down to clamp and hold down untrimmed solid wood to secure against slippage in the course of trimming.
- Electrical interlocking of the door in the machine frame to change over the belt to change the rotational speed (only with three-speed model). It is not possible to switch on the machine when the door is open, and if the door is opened while the machine is running, the drives will switch off.
- Sliding table arresting device to prevent workpiece kick-back for insert cuts together with the cross-stop.
- Automatic brake which, after switching off, brings the main saw blade to a standstill in less than 10 seconds, regardless of the saw blade diameter and rotational speed.
- Ergonomic arrangement of the operating elements at readily accessible positions.

### 3 Product description

---

#### 3.7.3 Top safety hood/riving knife

For a max. tool diameter of 400/500/550 mm:

- Top safety hood fitted separately from the riving knife for max. saw blade diameter of 400/500/550 mm, available in a narrow and a wide format made of polycarbonate to optimally cover the section of the blade not required for sawing above the machine table with a safeguard against lifting beyond the maximum cutting height of + 5 mm. Rollers integrated in the safety hoods at the leading and trailing ends facilitate both feeding workpieces and pulling back workpieces if workpieces have a slightly different thickness.
- Laterally displaceable protective hood for machines with the option "Saw blade tilting to both sides"
- 3 riving knives for saw blades between 250 and 400/500 (550) mm diameter to avoid workpiece kick-back as a result of jamming in the cutting line.

www.DaltonsWadkin.com

### 3.7.4 Handling batteries / accumulators

#### Information on battery regulations



##### Note!

Dispose of used batteries according to the applicable laws and regulations at a communal collection point or return them to your retailer free of charge.

##### Danger caused by lithium batteries

If lithium batteries are used or stored outside of their specification, they may be dangerous. Dangers result primarily from incorrect handling and improper use.

Examples of improper use:

- mechanical damage (internal short-circuit)
- thermal stress (internal short-circuit)
- overloading (strong temperature increase due to exothermic processes).

*In Germany:*

According to § 5 ArbSchG (German Occupational Safety and Health Law), § 3 BetrSichV (German Industrial Safety Law), the owner/user must create a risk assessment to assess the dangers caused by technical equipment and devices.

##### Measures for damage prevention

The risk potential of lithium batteries is, in addition to the product design, primarily determined by the module or system capacity. The types used by Altendorf are low-capacity lithium batteries (batteries > 1 kg). The information for damage prevention applies to both new and used batteries.

##### General safety regulations

Always observe the following safety regulations:

- Adhere to all specifications by manufacturers and on safety data sheets
- Prevent external short-circuits
- Prevent internal short-circuits (protect from mechanical damage)
- Immediately and properly dispose of damaged products (even in case of slight damage)
- Do not expose directly and permanently to high temperatures or sources of heat (e.g. direct sunlight)
- Train employees in the proper handling of lithium batteries (as with hazardous materials)

### 3 Product description

---

Source: VdS 3103 : 2012-06 (01)

Lithium batteries - Excerpt of the GDV leaflet for damage prevention

www.DaltonsWadkin.com



## 4 Definitions

### 4.1 Description of machine

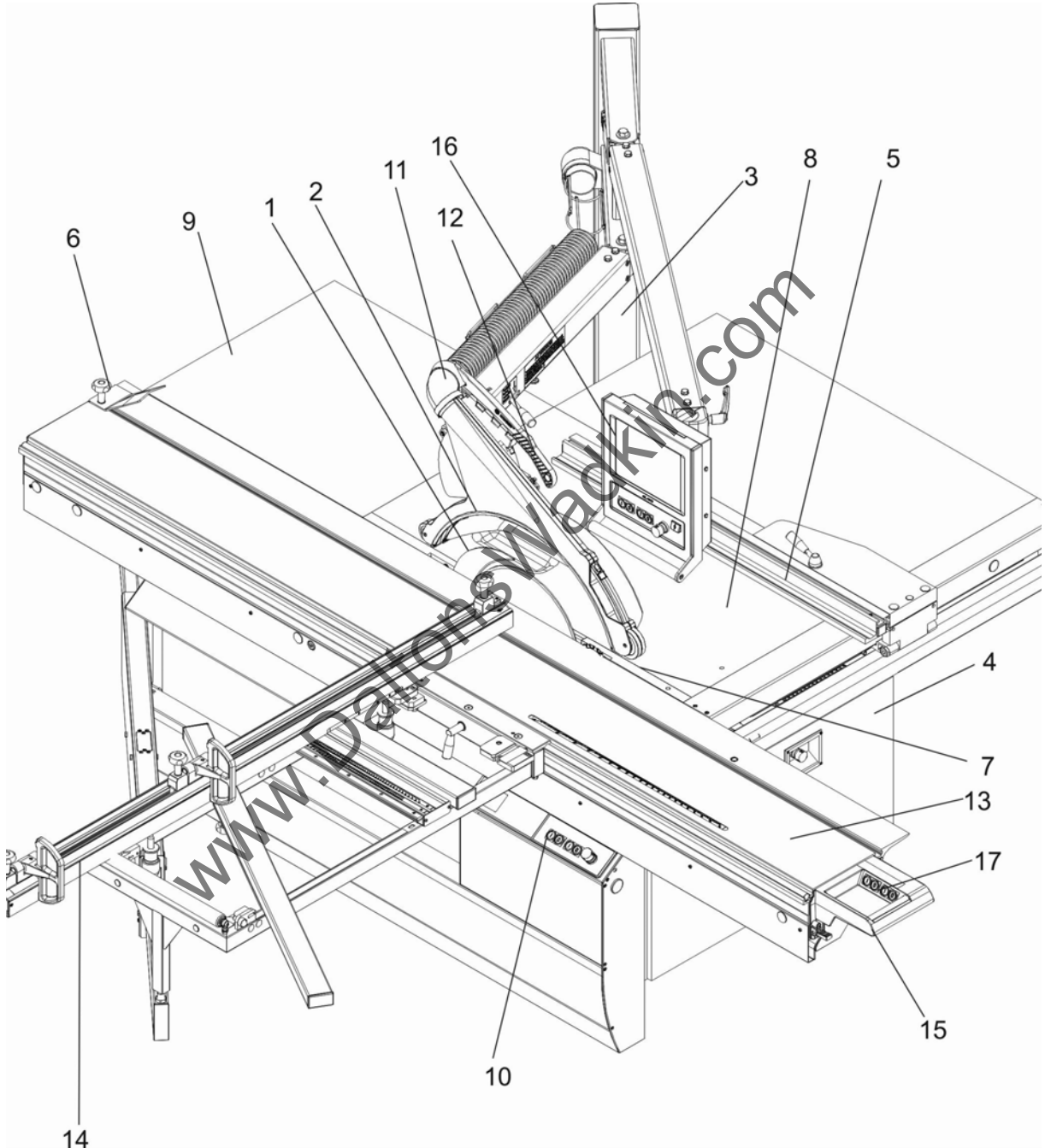

Fig. 4-1 Description of the sliding table saw

## 4 Definitions

1. Riving knife
2. Saw blade, protective hood
3. Protective hood support
4. Fixed guards beneath the table
5. Rip fence
6. Trimming hold-down device (clamping shoe)
7. Table insert
8. Machine table
9. Table length extension
10. Fixing elements
11. Protective hood holding fixture
12. Push stick
13. Sliding table
14. Crosscut fence
15. Sliding table handle
16. Movable operating terminal
17. Additional fixing elements on the rear end of the sliding table (optional)



## 4.2 Terms

### **Scoring**

Creation of a shallow cut in the surface of a workpiece, deep enough to pass through any coating on the workpiece, so as to prevent damage to the underside when the main saw blade makes its cut.

### **Scoring blade**

A blade that is located in front of the sawing blade, used to score the workpiece and rotate along with the feed direction.

### **Grooves**

Creation of cuts in the surface of the workpiece not deep enough to pass through using the saw blade or a milling tool.

### **Machine drive**

Power driven device to effect a machine movement

### **Hand feed**

Holding and/or guiding the workpiece manually.

www.DaltonsWadkin.com

## 4 Definitions

### **Removable feeding device**

Feeding mechanism fastened to the machine such that it can be tilted out of the work position without tools or similar equipment

### **Safety appliance**

Additional device that is not an integral part of the machine but helps the operator to feed the workpiece safely, e.g. a push block or push stick.

### **Kick-back**

Unexpected sudden movement of the workpiece or parts of it opposite to the direction of feed in the course of sawing.

### **Riving knife**

Protection against workpiece kick-backs and unintentional contact with the rising gear rim.

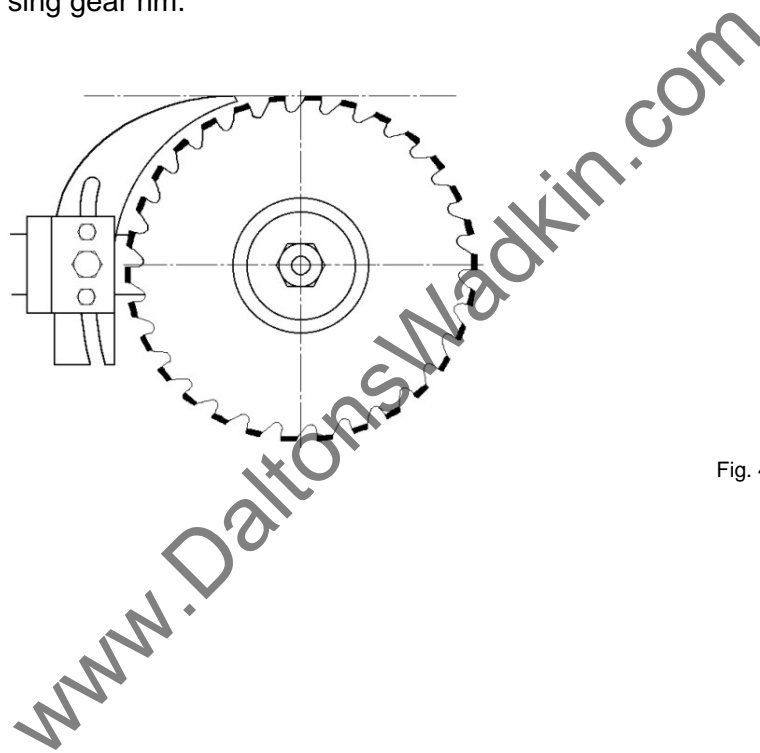

Fig. 4-2 Force-guided riving knife

www.DaltonsWadkin.com

## 5 Transport, siting and installation

### 5.1 Transport

When transporting the sliding table saw by elevating truck or fork lift truck (forks only with unchangeable length), only lift the machine up slightly and secure it against tipping!

#### **Packaging**

The type of packaging depends on the type of transport. Unless otherwise contractually agreed, the packaging corresponds to the HPE guidelines established by Bundesverband Holzmittel, Paletten, Exportverpackungen e.V. (the German Association for Wooden Materials, Pellets, Export Packaging) and the VDMA. Observe the symbols on the outside of the packaging!

#### **Degree of dismantling**

The degree of dismantling of the sliding table saw depends on the transport conditions and the options supplied with the machine. The sliding table is always shipped dismantled into several installation assemblies.

#### **Sensitivity**

Particular care must be taken when transporting the sliding table saw in order to avoid damage from force or poor loading and unloading. Knocks and condensation due to extreme temperature fluctuations must be avoided during transport.

#### **Intermediate storage**

If the sliding table saw or its assemblies are not installed immediately after delivery, make sure that they are stored in a protected location. They must be correctly covered to prevent any ingress of dust or moisture. Bare, non-surface-treated parts of the sliding table saw are protected with a conserving agent which will protect them for approx. 1 year. Reconservation is necessary if storage is to last longer than this period.

## 5.2 Safety measures before use/installation

### Installation site

No special foundations are required at the installation site for the sliding table saw. The floor must have a load bearing strength suitable for the machine weight and should be flat and level.

Select an installation site that provides enough clearance around the sliding table saw, allowing for the space requirements shown in the figure and the size of the workpieces to be cut. In addition, observe the safety clearances to parts of the building and other machines in order to eliminate the risk of crushing the operator or other personnel.

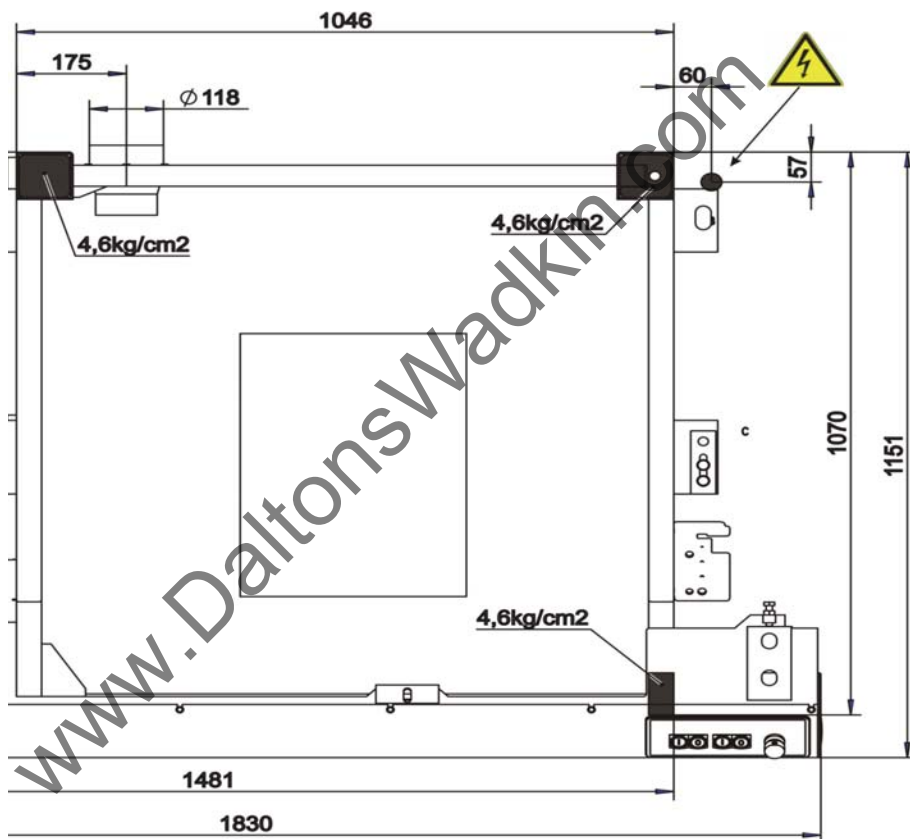

Fig. 5-1 Foundation plan

## 5 Transport, siting and installation

---



---

### **Danger!**

### **Danger of crushing!**

- For operation with the max. workpiece weight, secure the machine against tilting!
  - Ensure that there is sufficient safety clearance from building parts and other machines!
- 

www.DaltonsWadkin.com



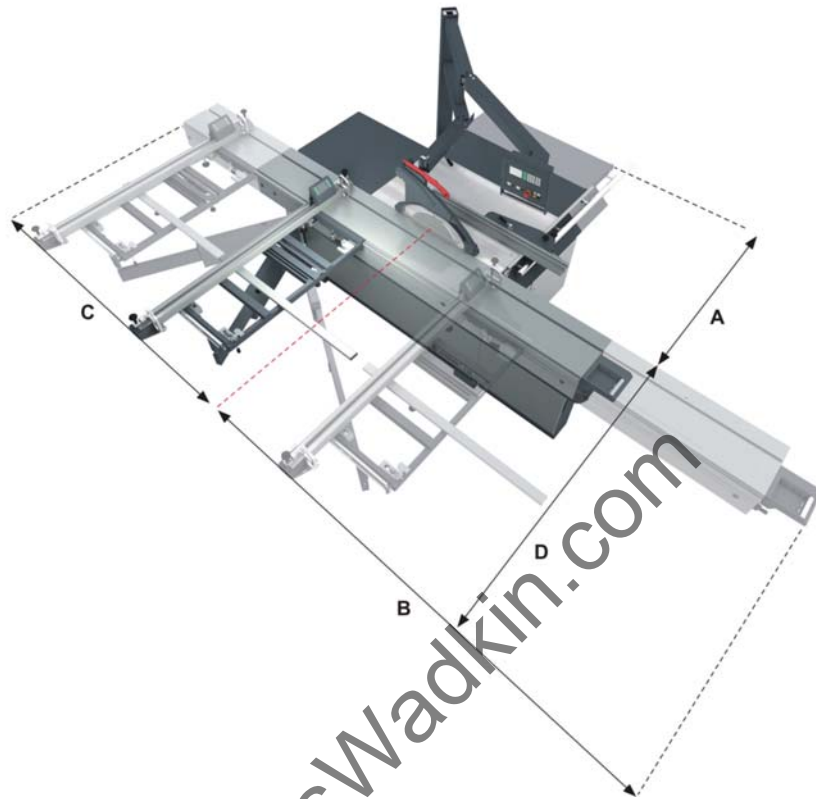

Fig. 5-2 Space requirement

**Key**

**Dimension A:**

Manual adjustment PA: Cutting width + 280 mm

Motor-driven adjustment PA: Cutting width + 3600 mm

**Dimension B: Sliding table length + 360 mm**

**Dimension C:** Sliding table length + 290 mm; sliding table length + 30 mm with TSD

**Dimension D:**

Crosscut fence: 1890 - max. 3420 mm

Crosscut mitre fence and PQS: 1960 - max.3690 mm

CNC crosscut fence UNO/DUO: 2200 - max.3670 mm

## 5 Transport, siting and installation

---

### ***Fixing***

A fixing element is provided on the side of the machine frame to ensure the machine stays in position. Once the sliding table saw has been set up, loosen the screws and lower the fixing down to the floor. Then retighten the two screws.



### 5.3 Installation

#### 5.3.1 Telescopic tube for swinging arm



Fig. 5-3 Installing the telescopic tube

- [1] Undo the cheese head screw
- [2] Push in the telescopic tube from the front through the housing for the swinging arm
- [3] Insert and tighten the cheese head screw

## 5 Transport, siting and installation

---

www.DaltonsWadkin.com

Fig. 5-4 Installing the telescopic tube, 4th axis

### 5.3.2 Main table length extension

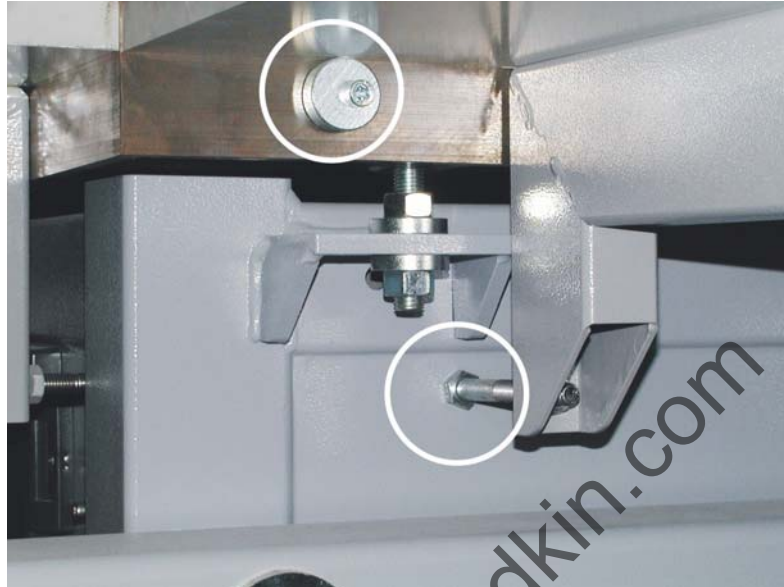

Fig. 5-5 Installing the main table length extension

- [1] Guide the bolts of the table length extension into the front holes of the main table.
- [2] Loosely secure to the main table with two M10 nuts and U-shaped washers
- [3] Place the main table length extension on the eccentrics.
- [4] Tighten the M10 nuts.
- [5] If necessary, correct the alignment and flushness by readjusting the eccentrics and the support screws.

**For table length extensions with floor support:**

## 5 Transport, siting and installation

### 5.3.3 Rip fence



Fig. 5-6 Installing the main table width extension

- [1] Guide the bolts of the main table width extension into the front holes in the table, and place the extension on the eccentrics
- [2] Loosely secure to the main table with two M10 nuts and U-shaped washers
- [3] Tighten the M10 nuts.
- [4] If necessary, correct the alignment and flushness by readjusting the eccentrics and the support screws.



Fig. 5-7 Installing the measuring bar

- [1] Fit the measuring bar easily with M6x30 countersunk screws (1)
- [2] Knock a 6x45 clamping pin (2) through
- [3] Tighten the countersunk screws(1)

### 5.3.4 Cross-slide and crosscut fence

#### Cross-slide

The cross-slide must be attached to every point of the exterior round bar of the sliding table, and must be clamped.

Carry out installation as follows:

- Place the supporting pipe of the cross-slide on the bolt of the telescopic tube
- tilt the cross slide to the sliding table, hook it in and clamp it using the eccentric lever; for the operation of the eccentric lever, refer to the following pages.

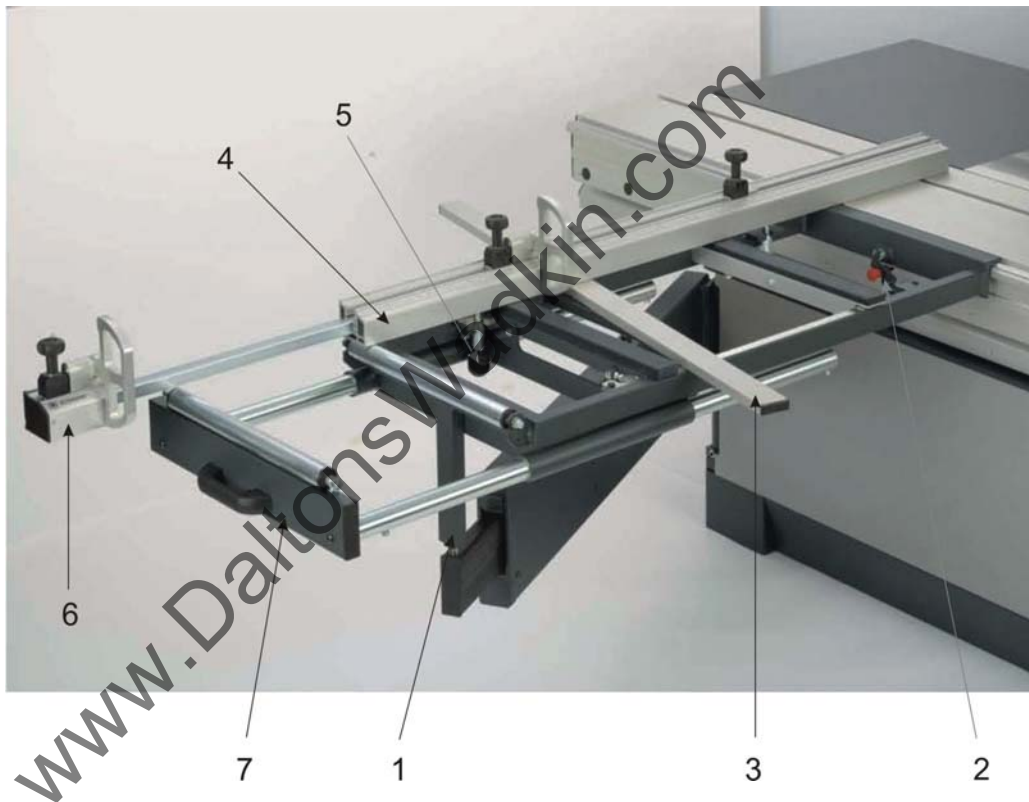

Fig. 5-8 Installing the cross-slide

- [1] Support pipe
- [2] Eccentric clamping lever
- [3] Workpiece support
- [4] Crosscut fence
- [5] Crosscut fence clamping
- [6] Extendable crosscut fence extension
- [7] Extendable cross-slide width extension (option)

### Description of the cross-slide clamping mechanism WA/WGA/CNC cross-cut fence UNO

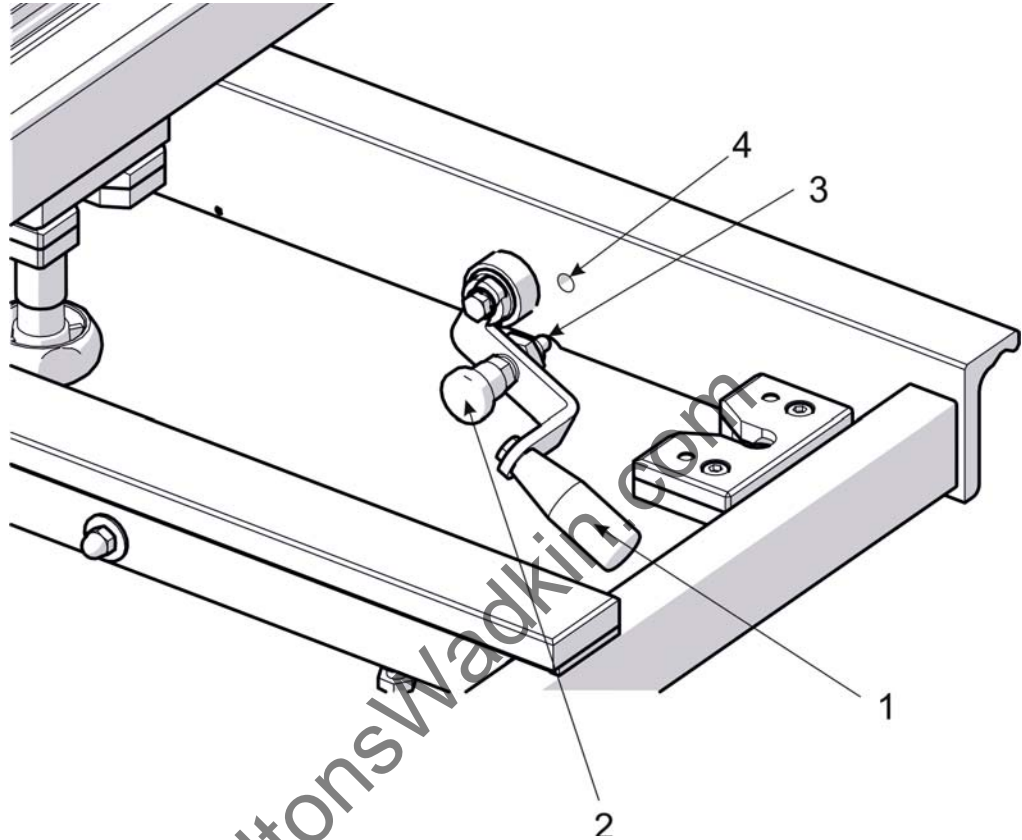

Fig. 5-9 Clamping lever

- [1] Clamping lever
- [2] Safety locking mechanism
- [3] Stop, safety locking mechanism for displacing the cross-slide
- [4] Drill hole, safety locking mechanism for removing the cross-slide

To push the cross-slide to other positions on the sliding table, undo the clamping lever [1] up to the stop of the safety locking mechanism. It is now possible to displace the cross-slide without a risk of the cross-slide falling down.

To remove the cross-slide, pull out the safety locking mechanism and push up the clamping lever. The safety mechanism engages in the hole [4]. The cross-slide can now be removed completely.

When assembling the cross-slide, first hook it in, pull out the safety locking mechanism, push the clamping lever all the way to the fixed stop. Release the safety locking mechanism.



### Description of the cross-slide clamping mechanism CNC crosscut fence

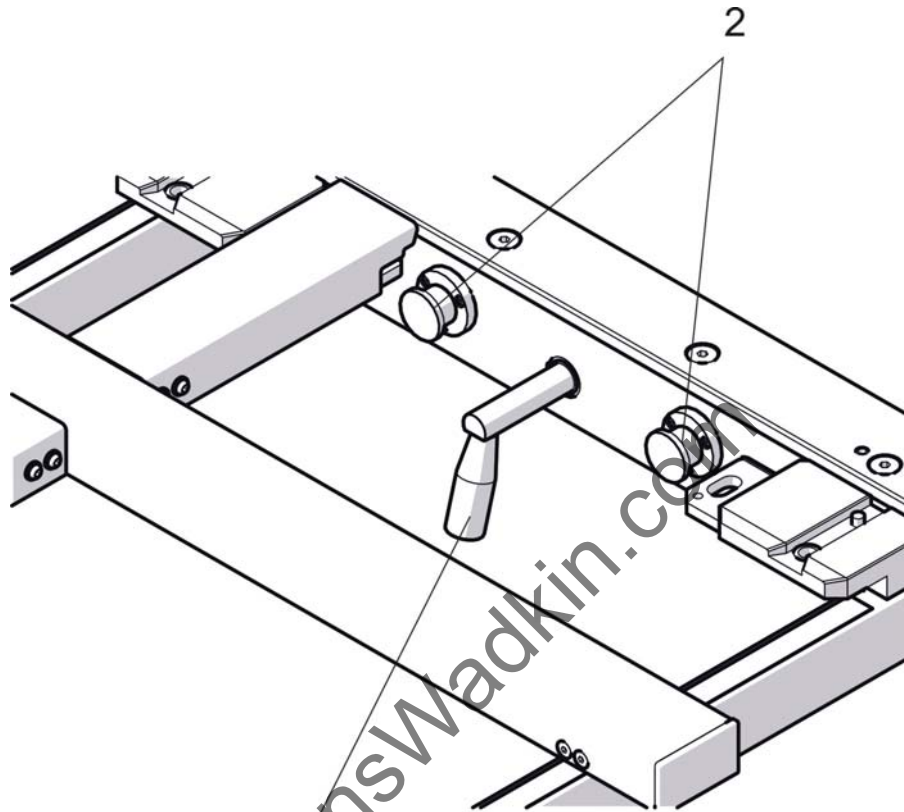

Fig. 5-10 Cross-slide clamping, CNC crosscut fence DUO

- [1] Eccentric clamping lever
- [2] Safety locking mechanism

To push the cross-slide to other positions on the sliding table, undo the clamping lever [1]. It is now possible to displace the cross-slide without a risk of the cross-slide falling down.

To remove the cross-slide, pull out the safety locking mechanisms and turn them. The safety locking mechanisms engage. The cross-slide can now be removed completely.

When assembling the cross-slide, first hook it in and push the clamping lever all the way to the fixed stop. Undo the safety locking mechanism and turn to engage.

### Crosscut fence, 90° only

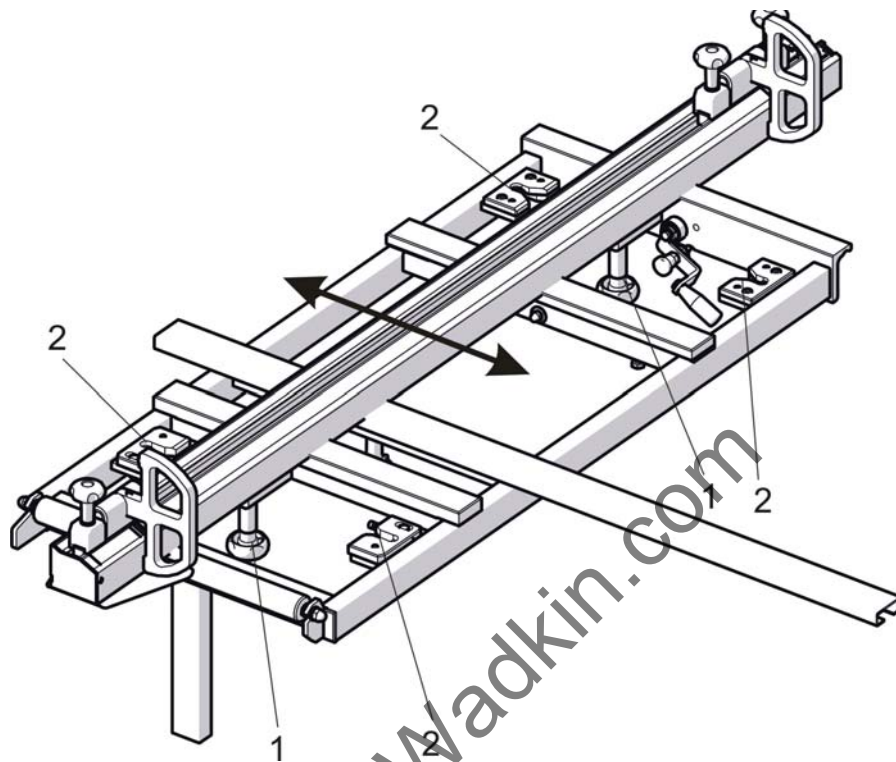

Fig. 5-11 Installing the 90° crosscut fence

1. Place the crosscut fence on the cross-slide such that the clamping bolts [1] can be inserted in the grooves [2]
2. Tighten the clamping bolts [1], positioning is carried out by means of the tapered surfaces

### Changing the 90° crosscut fence

1. Undo the clamping bolts [1]
2. Move the crosscut fence to a new position; ensure that the clamping bolts are inserted into the grooves
3. Tighten the clamping bolts, positioning is carried out by means of the tapered surfaces

---

### Warning!



***In the case of the "tilting to both sides" option, only use the crosscut fences supplied with this machine!***

---

### Crosscut-mitre fence

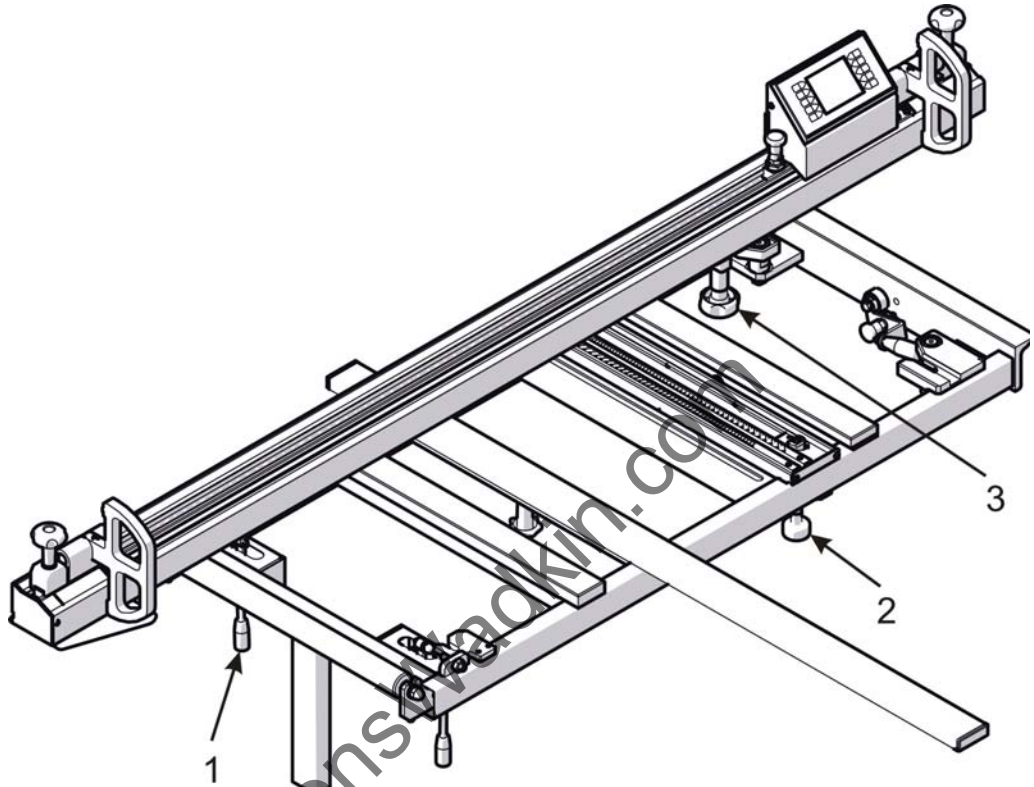

Fig. 5-12 Crosscut-mitre fence operating elements

- [1] Clamping lever 90° position
- [2] Indexing bolt for angle measurement
- [3] Clamping pivot point

**Installing** the standard crosscut-mitre fence / with DIGIT L + LD:

- Place the crosscut-mitre fence on the rear fence surface
- Push the ball bearing over the groove in the sliding table
- Unscrew the handle of the degree scale clamping
- Carefully turn the crosscut-mitre fence by 90° so that the ball bearing can be inserted in the groove of the sliding table and the threaded bolt of the clamping degree scale in the groove of the profile
- Fasten the handle of the clamping degree scale

## 5 Transport, siting and installation

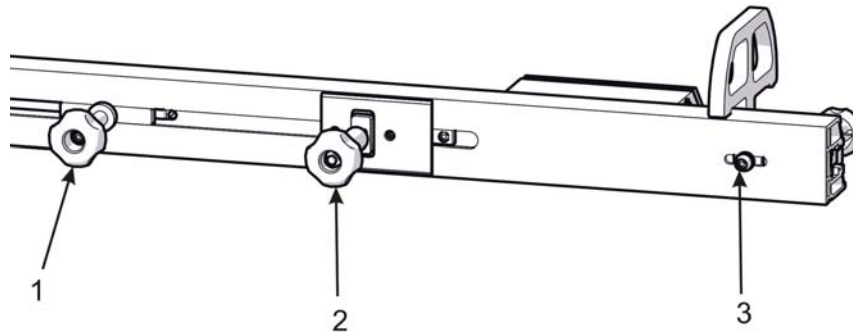
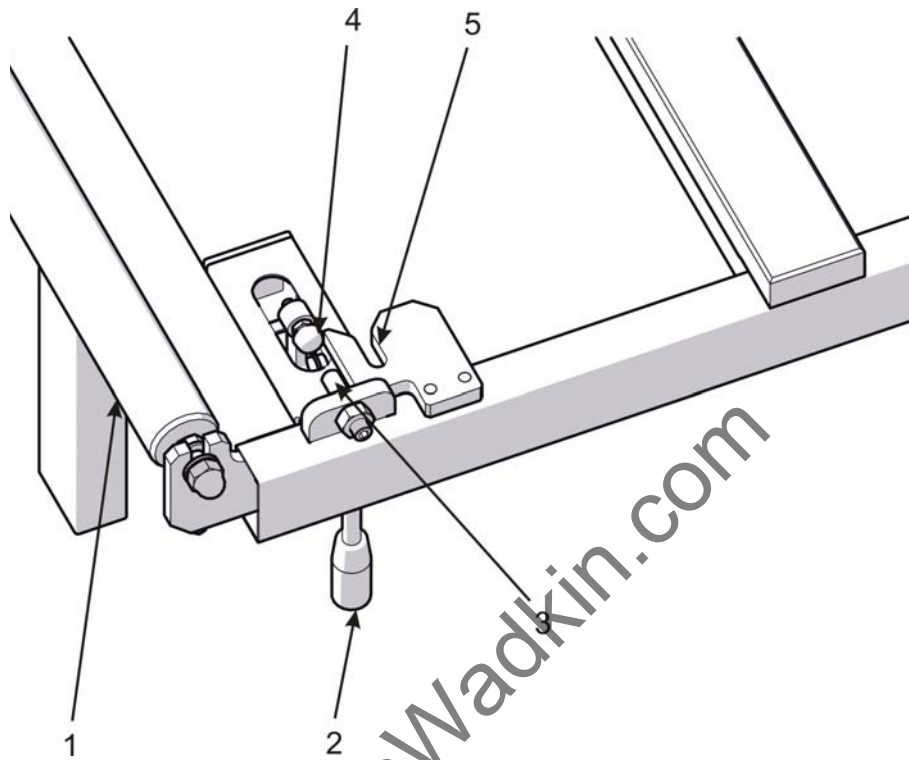

Fig. 5-13 Installing the crosscut-mitre fence

- [1] Clamping degree scale
- [2] Clamping pivot point
- [3] Ball bearing

www.DaltonsWadkin.com

90° clamping



- [1] Support roller
- [2] Clamping lever
- [3] 90° stop
- [4] Pressure piece on the clamping lever
- [5] Guide groove

Fig. 5-14 90° clamping

## 5 Transport, siting and installation

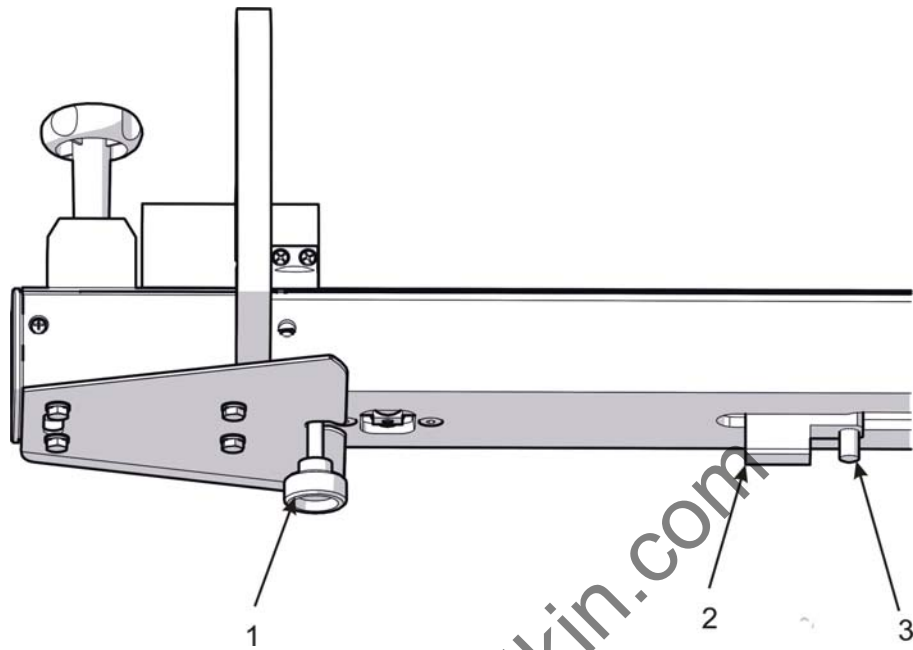

Fig. 5-15 Crosscut-mitre fence left-hand side

- [1] Clamping screw, telescopic extension
- [2] Clamping piece, 90° position
- [3] Guide pin

### Crosscut-mitre fence WGA\_LD

Crosscut-mitre fence with digital angle and length measurement

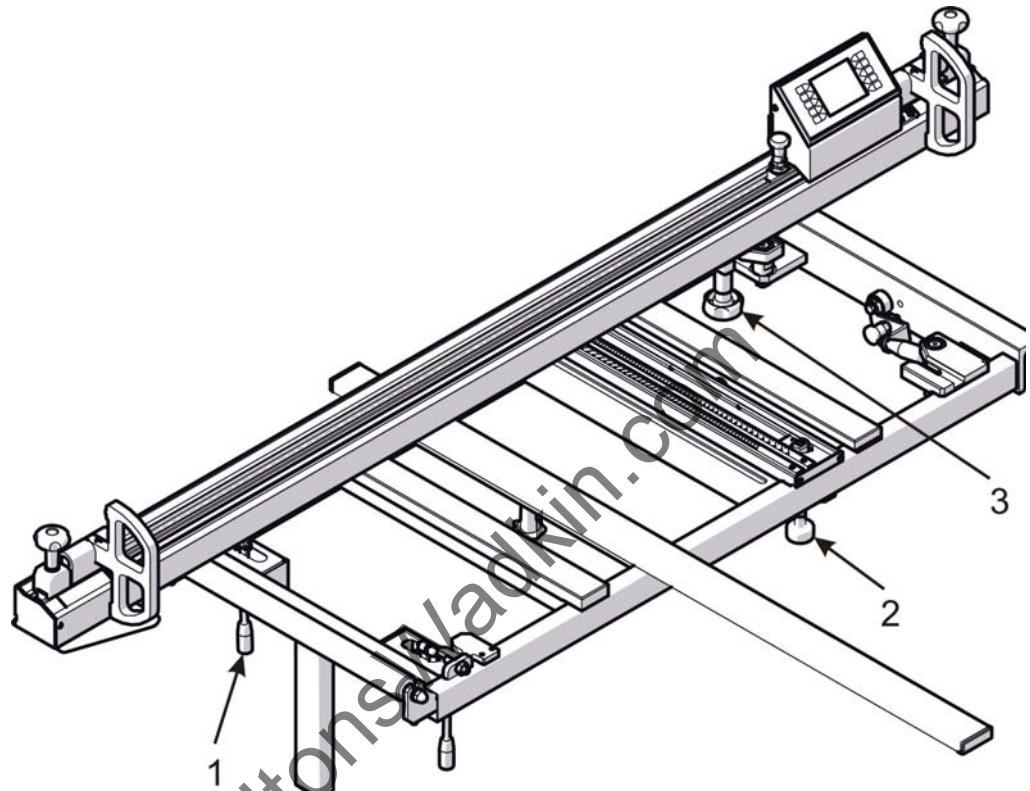

Fig. 5-16 WGA\_LD

- [1]
- [2] Lower the crosscut-mitre fence so that the bolt enters the guide carriage hole
- [3] Turn in clamping screw 1 loosely

## 5 Transport, siting and installation

Operating elements:

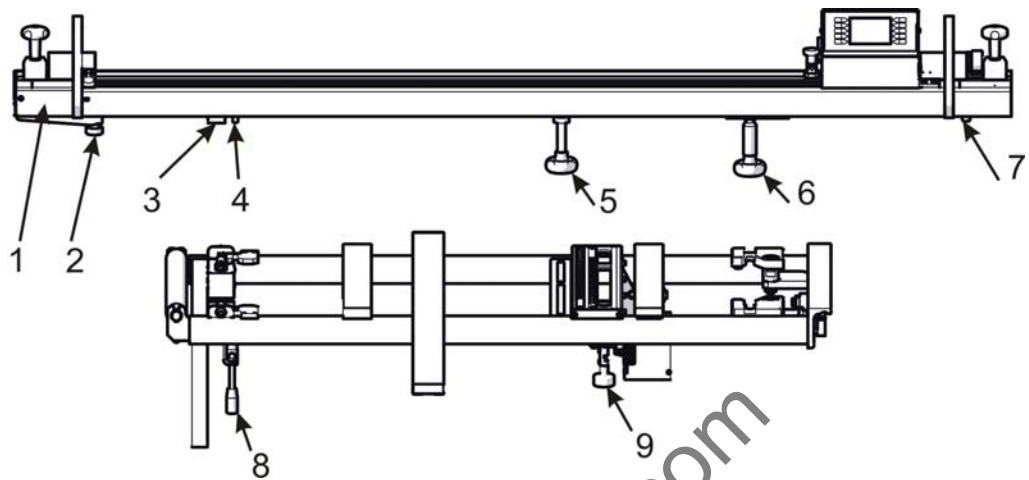

Fig. 5-17 WGA\_LD

- [1] Telescopic extension
- [2] Clamping, telescopic extension
- [3] 90° stop
- [4] Guide pin, 90° position
- [5] Clamping degree scale
- [6] Clamping pivot point
- [7] Guide roller, sliding table
- [8] Clamping lever, 90° position
- [9] Indexing bolt, angle measurement



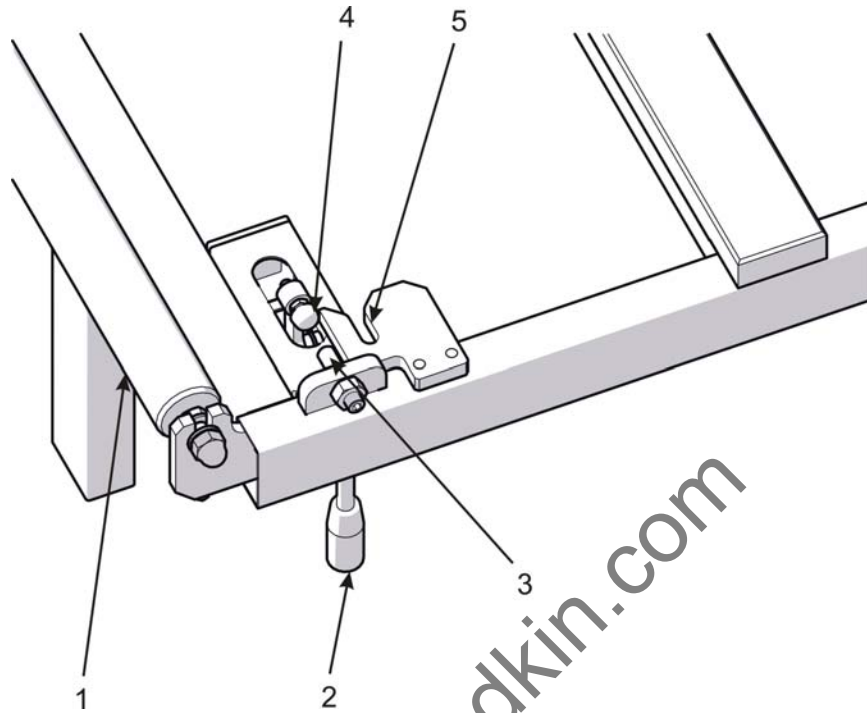

Fig. 5-18 90° clamping

- [1] Support roller
- [2] Clamping lever
- [3] 90° stop
- [4] Pressure piece on the clamping lever
- [5] Guide groove

## 5 Transport, siting and installation

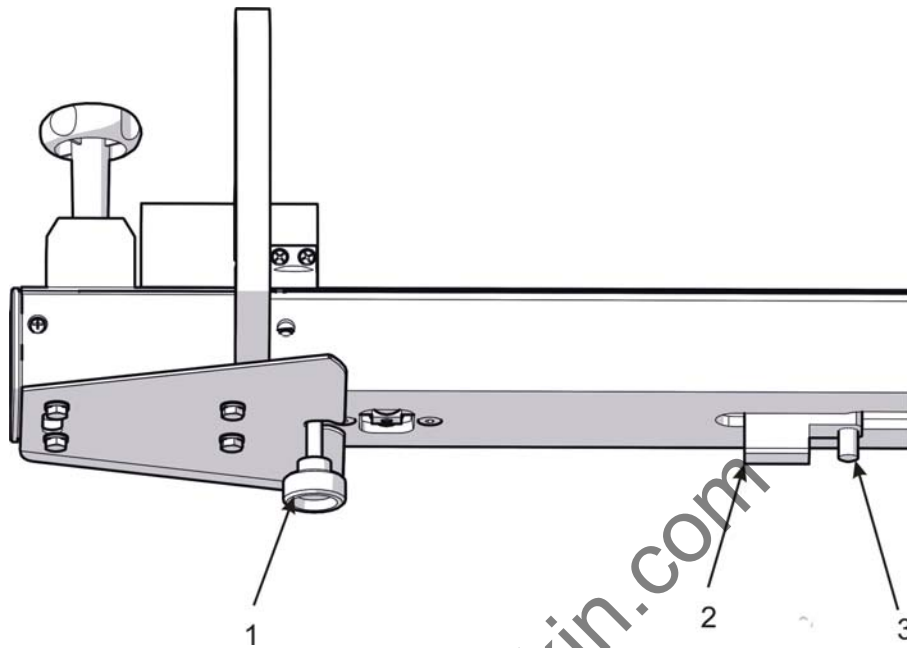

Fig. 5-19 WGA\_LD, LH side

- [1] Clamping screw, telescopic extension
- [2] Clamping piece, 90° position
- [3] Guide pin

### CNC crosscut fence

Operating elements, CNC crosscut fence UNO

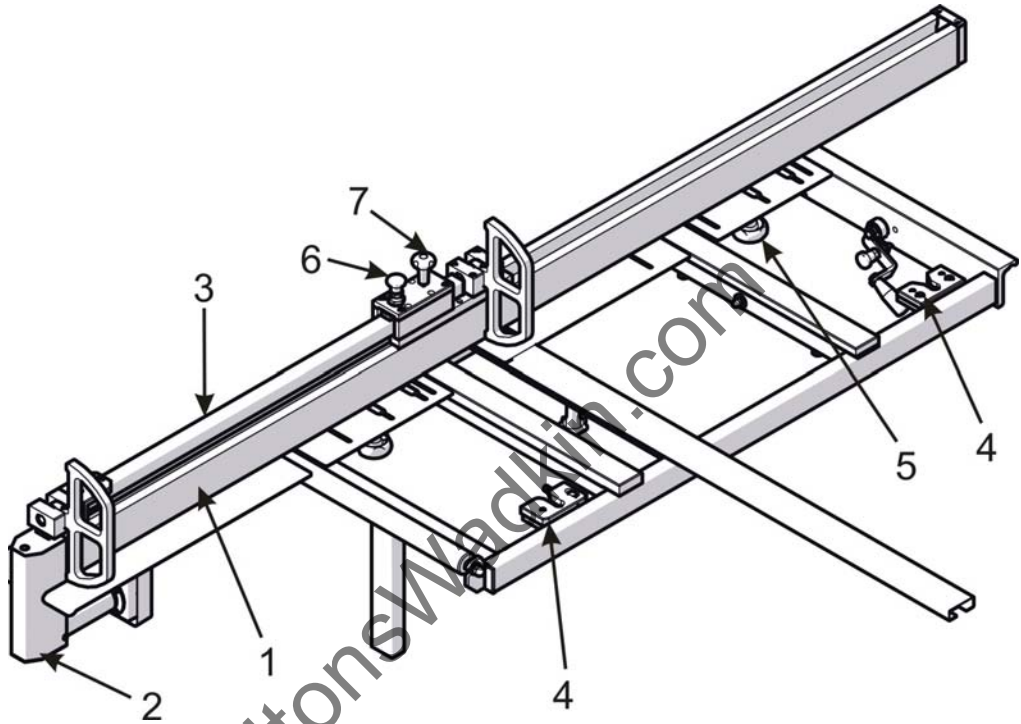

Fig. 5-20 CNC crosscut fence DUO

- [1] Stop fence
- [2] Axis drive
- [3] Axis extension
- [4] 90° stop
- [5] Clamping screws
- [6] Indexing bolt, extension
- [7] Clamping screw, extension

## 5 Transport, siting and installation

### Extension:

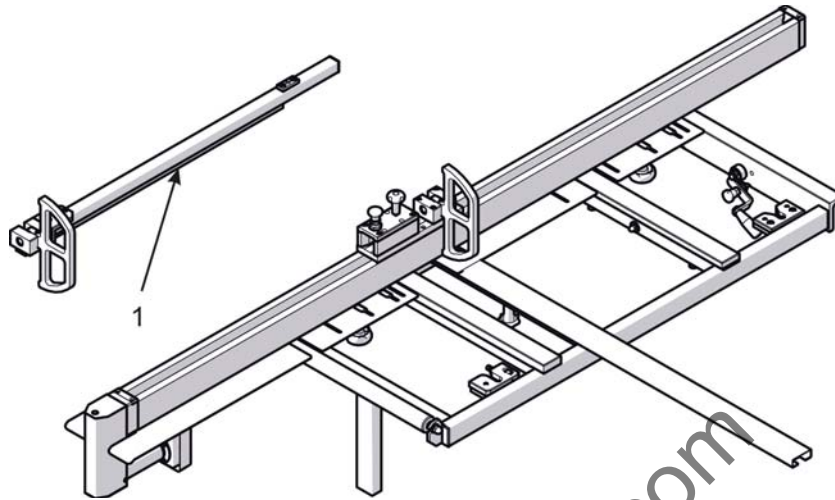

Fig. 5-21 Extension, CNC crosscut fence UNO

[1] 1000 mm extension piece

### Installing the extension:

- Insert the extension into the guide until the indexing bolt engages
- Tighten the clamping screw.
- When using the second throw-over stop, the adjustable dimension increases by 1000 mm

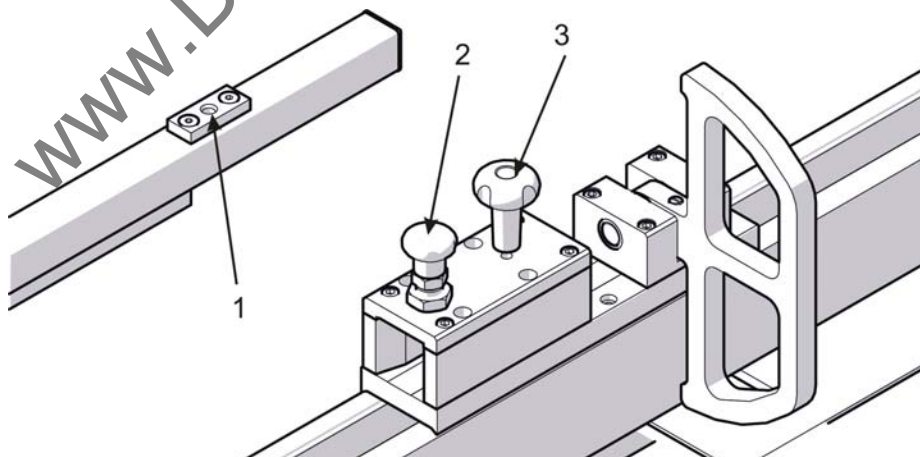

Fig. 5-22 Extension installation

- [1] Locking hole, extension
- [2] Indexing bolt
- [3] Clamping, extension

Operating elements, 4th axis, heavy:

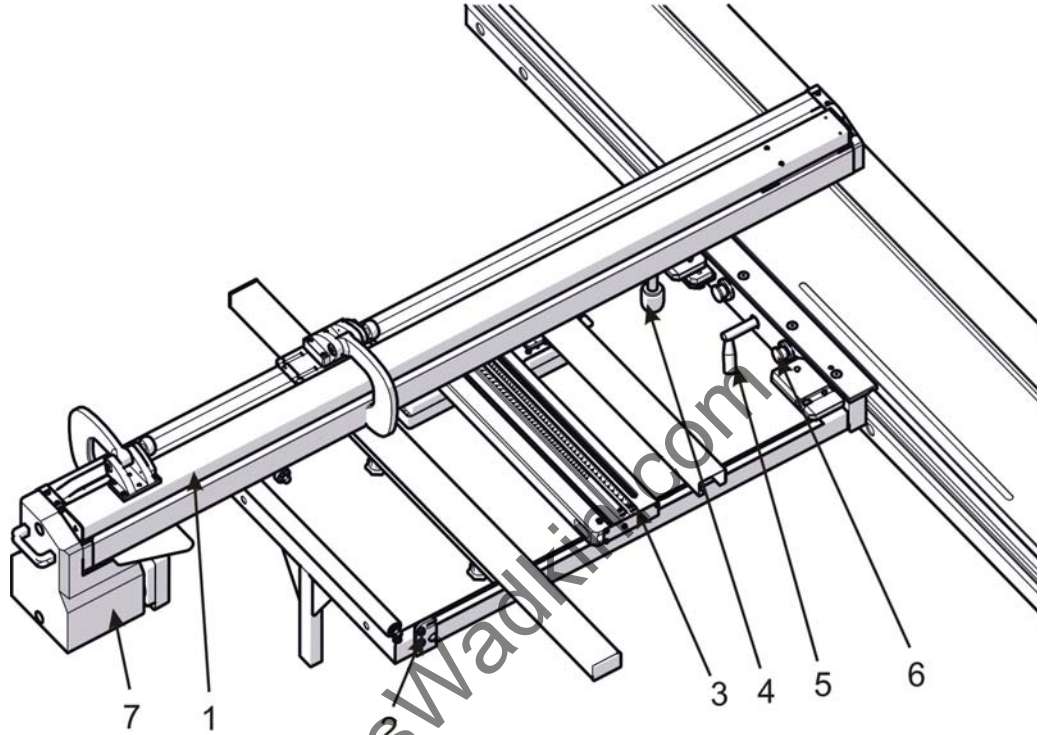

Fig. 5-23 Operating elements, 4th axis

- [1] 4th axis
- [2] 90° stop
- [3] Degree scale
- [4] Clamping pivot point
- [5] Clamping cross-slide
- [6] Cross-slide, locking mechanism
- [7] Drive

## 5 Transport, siting and installation

Installing the cross-slide:

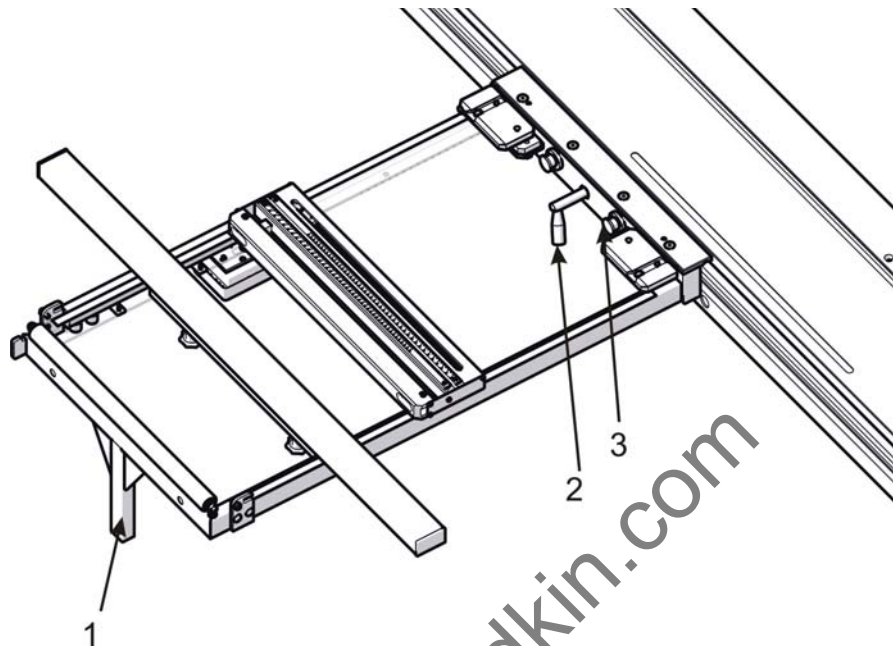

Fig. 5-24 Installing the cross-slide

- [1] Support pipe
- [2] Clamping, cross-slide
- [3] Cross-slide, locking mechanism

The cross-slide can be hooked in and clamped at any position on the sliding table as follows:

- Place the supporting pipe of the cross-slide on the bolt of the telescopic tube.
- Swing the cross-slide to the sliding table, hook it in and clamp it with the clamping mechanism.
- Engage cross-slide locking mechanism



Installing the 4th axis:

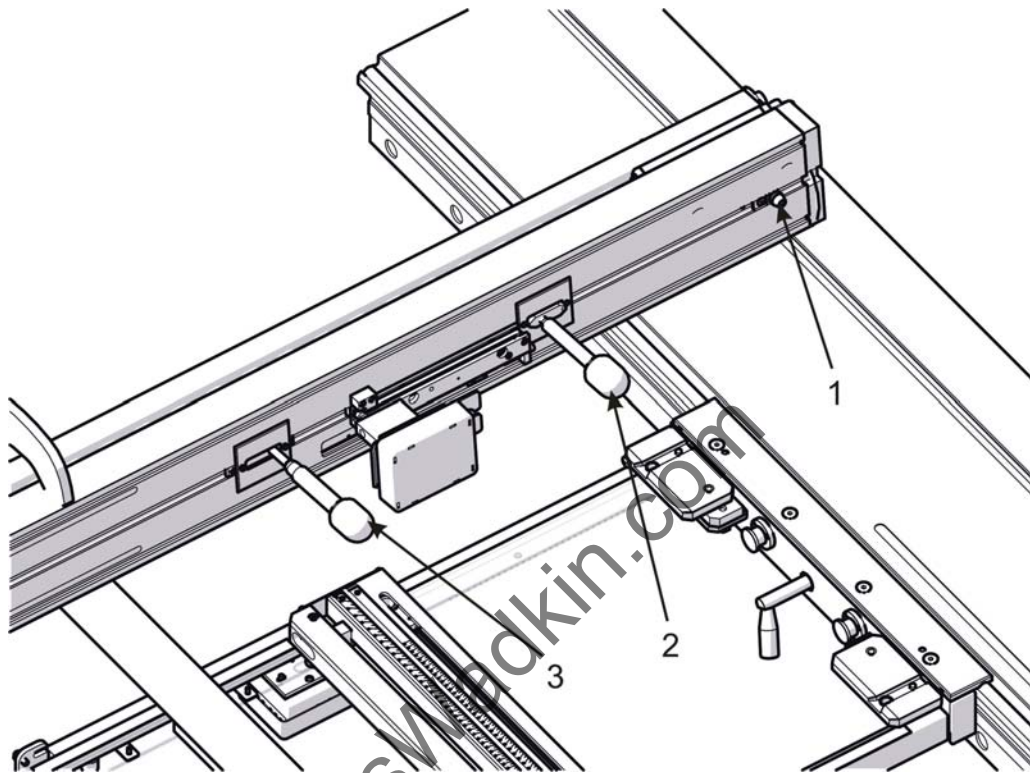

Fig. 5-25 Installing the 4th axis

- [1] Guide roller
- [2] Clamping pivot point
- [3] Clamping degree scale

Prior to assembly, unscrew the handle of the clamping, degree scale [3].

- Place the 4th axis on the rear fence surface
- Position the guide roller over the groove in the sliding table
- Position the degree scale clamping over the groove in the degree scale
- Position the guide carriage such that the distance between the stop fence and the hole in the guide carriage is 100 mm
- Turn the clamps 90° in the longitudinal direction
- Turn the 4th axis by 90°
- Check the guide roller in the roller carriage groove
- Push the pivot clamp to the right into the clamping plate and tighten the bolts
- Fasten the handle of the 'Degree scale clamping'
- Insert the plug connectors of the 4th axis underneath the telescopic tube.

## 5 Transport, siting and installation

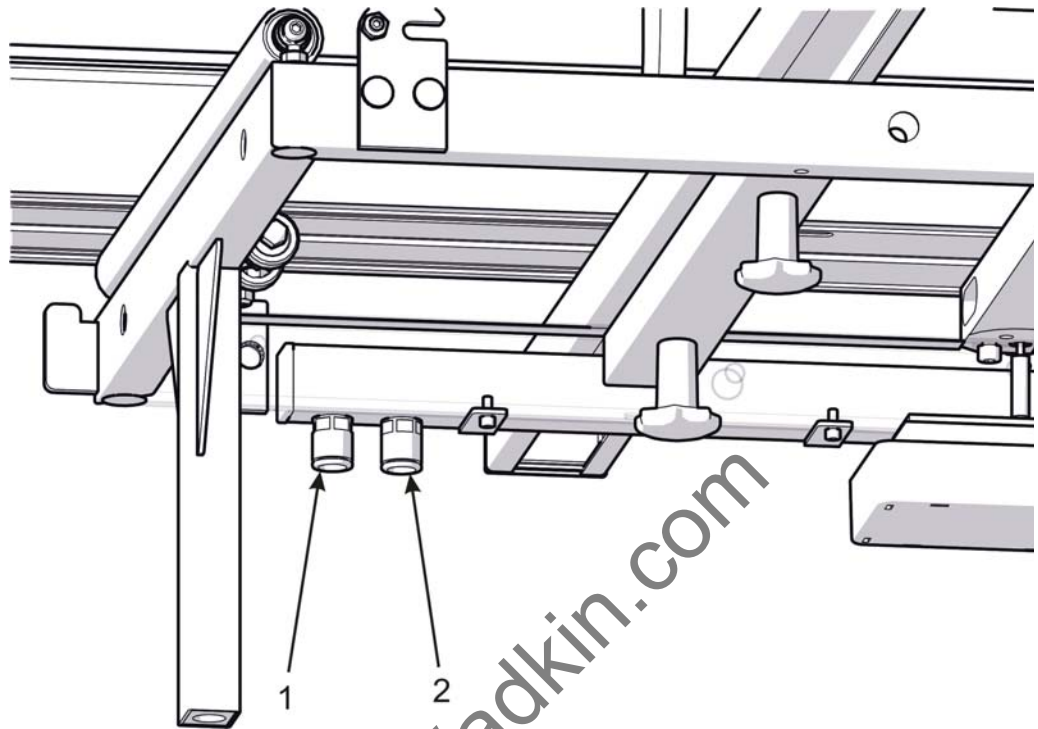

Fig. 5-26 Electrical connection

- [1] Socket 1
- [2] Socket 2



### Warning!

***The plug connectors have 3 and 5 poles, are marked in different colours and must only be connected or disconnected when the main switch is switched off.***

Non-adherence can lead to destruction of the plug connectors or the electronics.



### 5.3.5 Sliding table

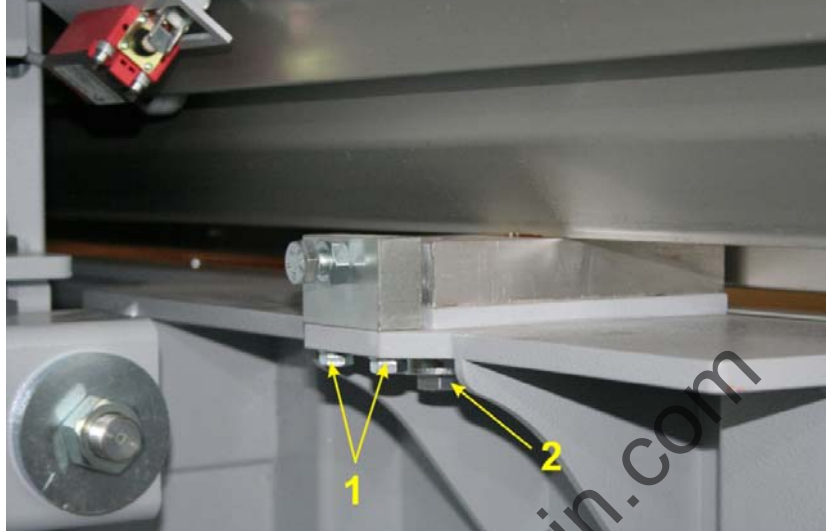

Fig. 5-27 Bottom carriage stop

- [1] Place the bottom carriage on the machine frame and push against the stop screws.
- [2] Screw on the bottom carriage using the outer fixing screws.
- [3] Only tighten the middle fixing screw loosely.

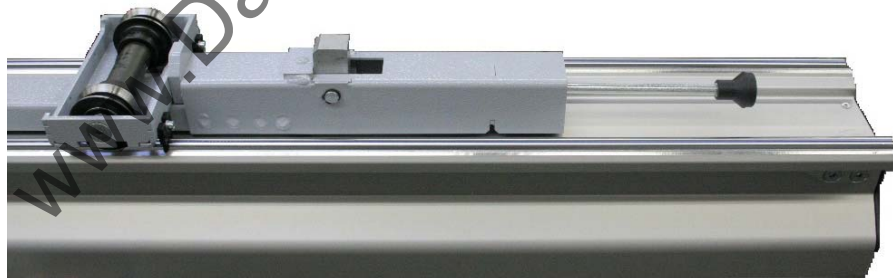

Fig. 5-28 Installing the middle carriage

- [1] Place the middle carriage on the bottom carriage so that the interlock is pointing to the right.
- [2] Push the middle carriage to the right until the 1st double roller is still just resting on the round bars. If this is not observed, in the case of the TIP-SERVO-DRIVE the end position sensors could be destroyed when the top carriage is pushed on!

## 5 Transport, siting and installation



Fig. 5-29 Installing the top carriage

- [1] Carefully push on the top carriage making sure it is not skewed, watch the e-chain.
- [2] Carefully push the guide rails onto the double rollers.
- [3] Push the top carriage towards the left, all the way to the stop.

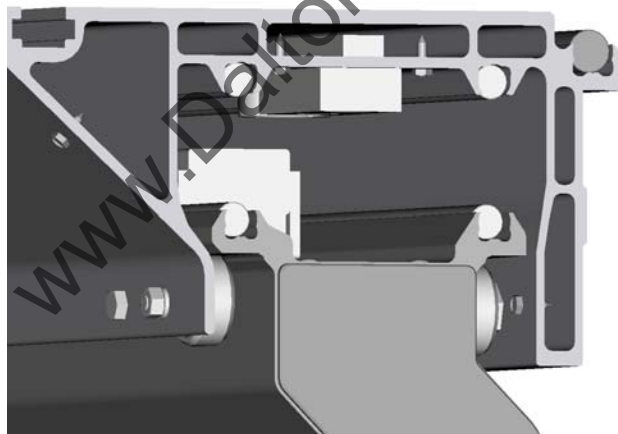

Fig. 5-30 Back stop

- [1] Fit the back stop



Fig. 5-31 Central fixing

- [1] Tighten the central fixing screw.
- [2] Check that the sub-rollers are correctly adjusted.



Fig. 5-32 Bracket on the bottom carriage

- [1] Fix the bracket to the bottom carriage with 3 screws.

## 5 Transport, siting and installation

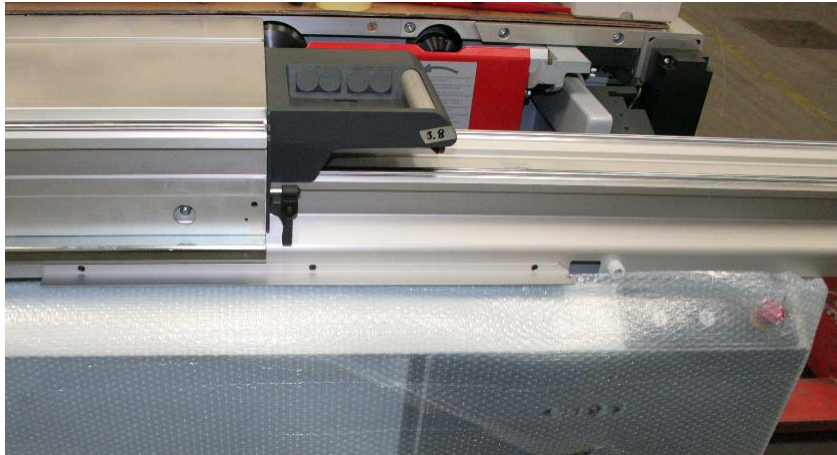

Fig. 5-33 Bracket on the bottom carriage

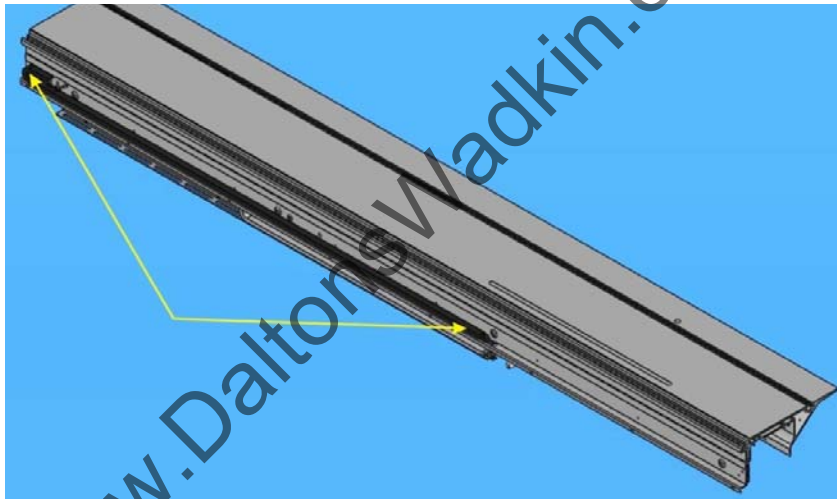

Fig. 5-34 Position of e-chain

- [1] Place the bottom e-chain on the bracket on the bottom carriage.
- [2] Run the cable into the machine frame through the opening in the bottom carriage.

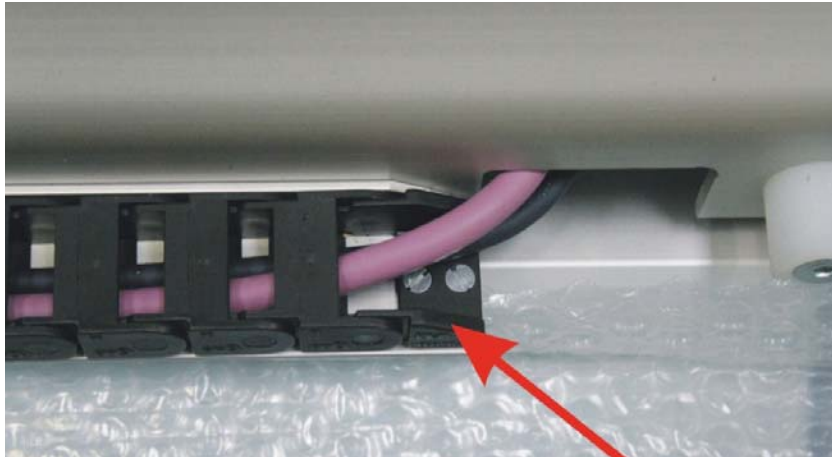

Fig. 5-35 Fastening the e-chain

[1] Screw the first link of the e-chain onto the bracket using 2 screws.

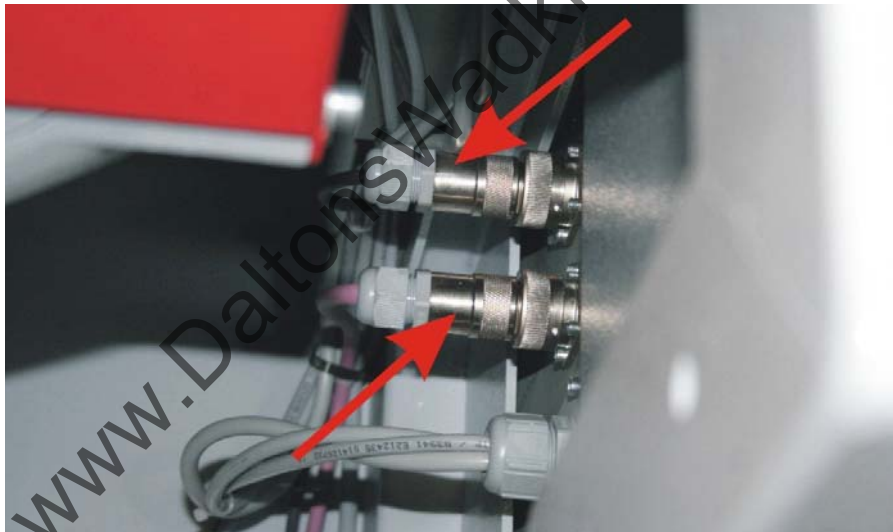

Fig. 5-36 Switch cabinet

[1] Connect the plug to the switch cabinet.  
[2] Tighten the cap nut.



**Warning!**

The connectors have 3 and 5 poles.

Ensure you plug the 3-pole connector into the 3-pole socket, otherwise the connector will be destroyed!

## 5 Transport, siting and installation

---

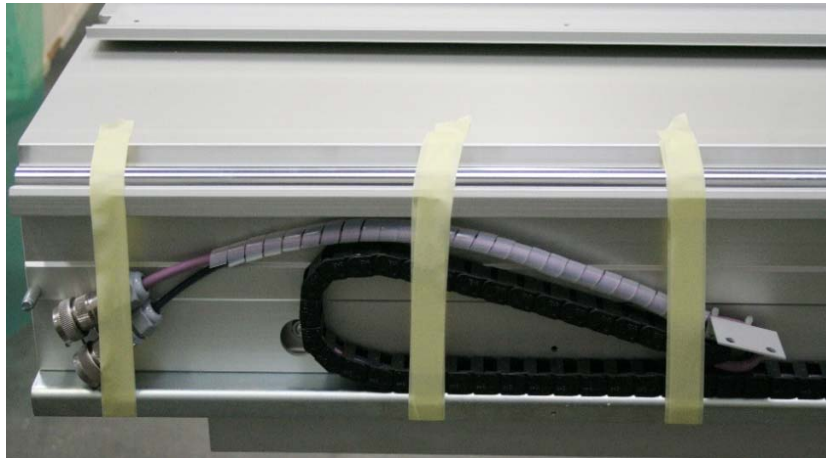

Fig. 5-37 Fastening the e-chain / cable

- [1] Remove all the packing tape.
- [2] Screw on the cover profile.

www.DaltonsWadkin.com



### 5.3.6 Electrical connection



#### Warning!

#### Dangerous electric voltage!

All work on the electrical equipment, including connection to the mains supply, may only be performed by a qualified electrician.

Disconnect the machine from the mains supply before working on the electrical equipment.

- After connecting the supply line, check the rotational direction of the main saw motor by briefly starting up and, if necessary, correct it by interchanging the two outer conductors in the mains connection box.
- Pay attention to the rotational direction arrow on the saw blade cover!
- As far as machines with a VARIO drive are concerned, check the rotational direction of the scoring saw motor, because the frequency converter ensures that the directional rotation of the main saw motor is always correct, regardless of the phase position.
- Only connect or disconnect plug-in connectors when the main switch has been turned off or disconnected!

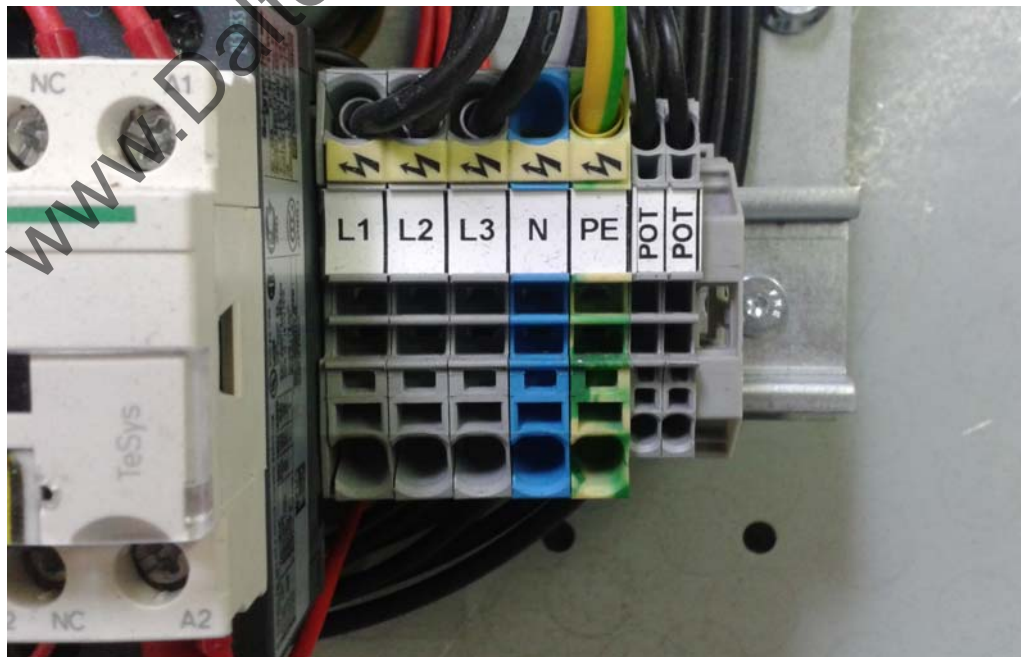

Fig. 5-38 Mains connection

## 5 Transport, siting and installation

---

The mains connection is in the RH switch cabinet on the right-hand side. The terminals for the supply line are marked L1, L2, L3, N and PE, the terminals for the potential-free contact with the control system of an extraction system are marked POT. The supply line cross-section and the fuses to be fitted by the user depend on the installed motor rating.

If the machine is connected via a flexible supply line, a rubber-sheathed cable (wire marking H07RN-F) must be used. Required plug-in device: Round connector in accordance with DIN 49463.

www.DaltonsWadkin.com



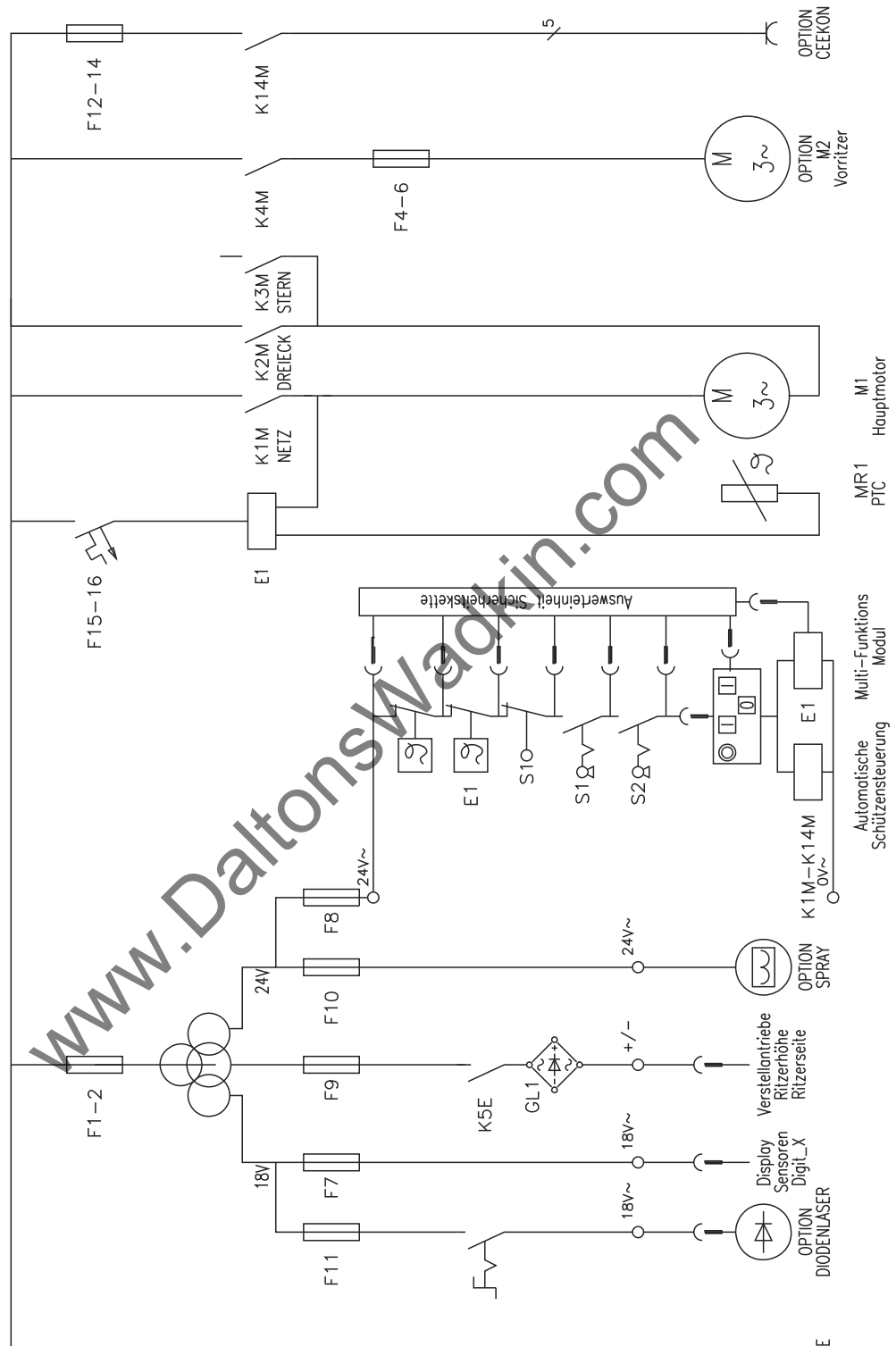

Fig. 5-39 Circuit diagram

## 5 Transport, siting and installation

Designation	Designation
GL 1	Rectifier
Q 1	Main switch
S 26	LASER option switch
M 1	Main saw motor
M 2	Scoring saw motor
MR 1	Temperature monitor for main saw motor
S 1	Sliding table safety switch
S 2	EMERGENCY STOP button
S 3	Temperature monitor for scoring saw motor
S 1	Machine door/cover plate safety switch
E 1	Multifunction module
F 1 - F 2	Control fuses (primary)
F 4 - F 6	Scorer motor (option)
F 7 - F 9	Control fuses (secondary)
F 10 - F 11	SPRAY / LASER control fuse (option)
F 12 - F 14	CEKON (option)
K 1 M - K 5 M	Motor contactors
K 5 E	Supply voltage contactor for adjustment drives
K 14 M	CEKON contactor (option)

### 5.3.7 Connecting the extraction system (customer side!)



Fig. 5-40 Bottom extraction connection

Total extraction system connection  $D = 140 \text{ mm}$

$V_{\text{min}} = 1150 \text{ m}^3/\text{h}$  at  $20 \text{ m/s}$

Bottom extraction connection  $D = 120 \text{ mm}$

***The hoses and Y-tube are not supplied as standard with the machine.***

The dust emission values – measured in accordance with the “Principles for Testing Dust Emission (Workplace-Related Dust Concentration) from Woodworking Machines” issued by the German trade association’s technical committee for wood – are under  $2 \text{ mg/m}^3$ . When the machine is attached to a correctly functioning extraction system with an air speed of at least  $20 \text{ m/s}$  (measured at the connection socket) you can assume it is and will stay compliant with the technical reference concentration (TRK) value for wood dust that is in force in Germany. For perfect and safe operation, the machine must be connected to the extraction system at the extraction sockets (rear of machine frame and protection hood support). The minimum air speed at the extraction sockets must be  $20 \text{ m/s}$ . The  $80 \text{ mm}$  extraction hose from the hood to the connection socket on the support tube is not supplied as standard. The extraction socket and hoses are not supplied as standard!

Make sure that the extraction system is switched on together with the machine. For this, you can use the existing potential-free contact (POT - refer to circuit diagram) or a current transformer installed in the supply line. When using spray device (SPRAY), make sure that you use a suitable moisture extraction system in order to avoid faults.

## 5 Transport, siting and installation

### 5.4 Basic machine setting

#### 5.4.1 Sub rollers on the sliding table

Basic machine setting is carried out at our factory during final assembly. It may be necessary to correct the machine's basic settings due to removal of various assembly groups, and transport and installation on site. The machine elements to be checked are described below.

##### Check the sub-rollers

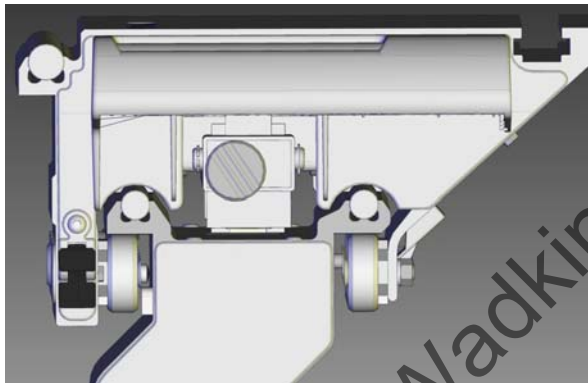

Fig. 5-41 Sub-rollers

The sub-rollers must run smoothly against the start slope at the start and end of the raceway. They should be set so that they can be held by hand with noticeable force and that they slip while the sliding table is moved.

##### Setting of the sub-rollers

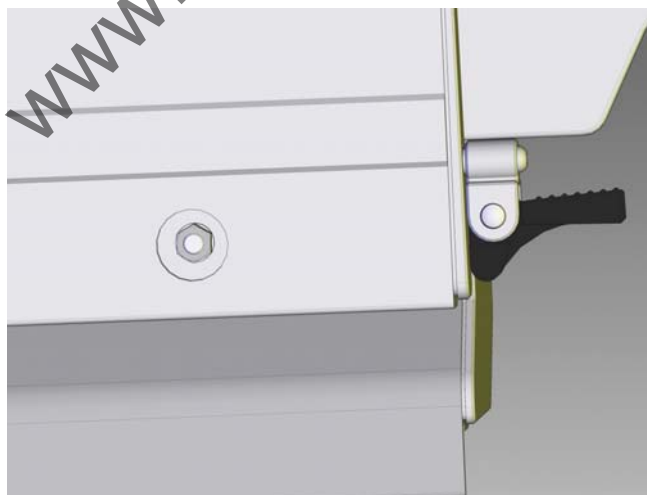

Fig. 5-42 Sub-rollers

The sub-rollers have eccentric bearings and can be adjusted.

The sub-rollers are set so that they can be held by hand with noticeable force and that they slip while the sliding table is moved. Adjusting them too tightly will result in stiff movement of the sliding table, and can lead to unwanted cutting results.

www.DaltonsWadkin.com

## 5 Transport, siting and installation

### 5.4.2 Main table

#### Checking the main table

Place a rip fence straight edge on the sliding table, and move the table into the middle position. Move the sliding table forward and backward; the main table must be approx. 1/10 mm lower.

#### Adjusting the main table

Release the lock nuts (1) of the 4 stay-bolts, adjust the main table, and tighten the lock nuts.

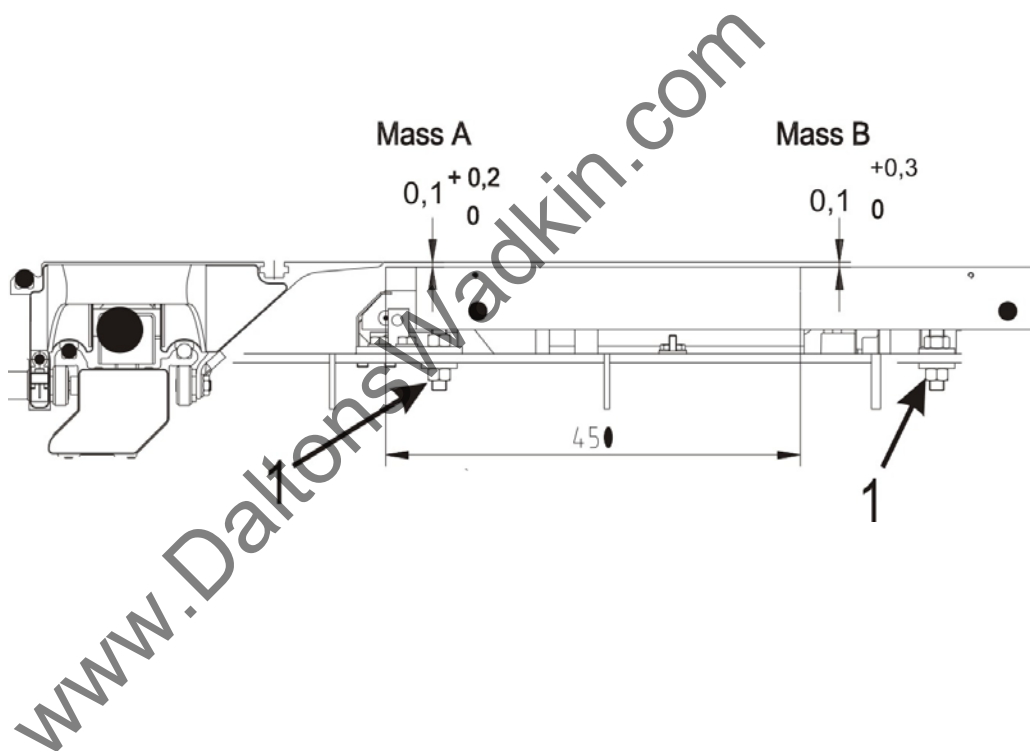

### 5.4.3 Swinging arm

#### Check



Rest the swinging arm against the machine frame, fully extend the telescopic tube of the swinging arm and check dimensions A and B. Set dimensions A and B with a tolerance of 0.5 mm; if necessary correct the setting with EX 1 and EX 2.

The dimension between the bottom edge of the crosscut fence profile and the top edge of the top carriage profile (see fig. 2) is a feature for the tolerance of the swivel arm setting. The dimension must not exceed the cut length possible with the cross-slide between 0.1 and 0.9 mm (check with feeler gauge).

## 5 Transport, siting and installation

### 5.4.4 Cross-slide height

#### Check

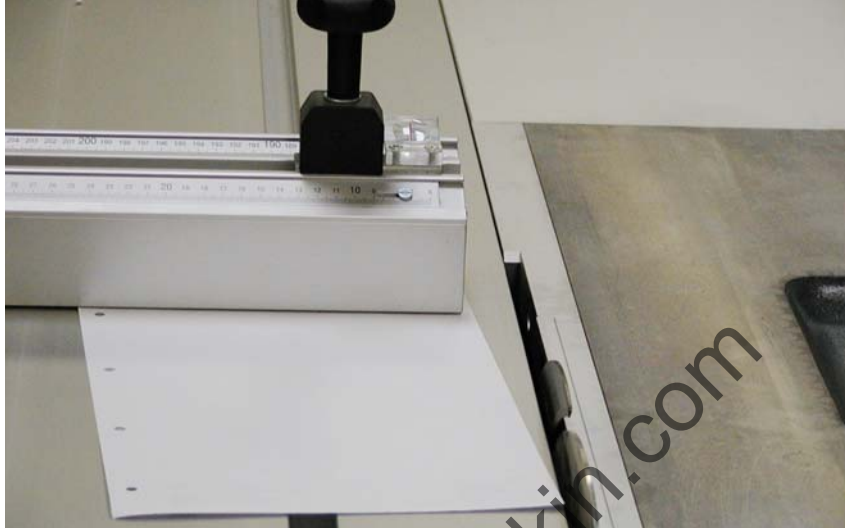

Fig. 5-43 Checking the cross-slide height

Push a piece of cardboard of approx. 0.5 mm thickness between the crosscut fence and the sliding table; it must be possible to move the cardboard freely in every position. The crosscut fence must be parallel to the surface of the sliding table!

#### Setting



Fig. 5-44 Adjusting the cross-slide height



Adjust the height of the swinging arm bolt and fix it with a lock nut. Check that the swinging arm is parallel if the gap changes in accordance with the position of the sliding table!

www.DaltonsWadkin.com

### 5.4.5 Setting free cut

#### Sliding table

##### Definition:

The sliding table, the saw blade and the rip fence are not parallel to each other, so the crosscut fence and the rip fence do not form a 90° angle. The sliding table runs to the left out of the direction, by a fraction of a millimetre. In the same way, the rip fence points slightly to the right so that a gap is created behind the saw blade.

The rising saw blade tooth must not recut, but free cut should be set as small as possible. When using a scorer, make sure that both free cuts are of an equal size.

##### Check:

Set the saw blade to maximum cutting height, and cut off an approx. 100 mm piece from an MDF test piece at the cross-cut fence. The noise difference between the cutting and non-cutting teeth lets you identify whether the sliding table is set correctly. When the rising teeth pass, only a slight fluttering should be heard compared to the noise of the cutting teeth.

##### Setting:

Release the sliding table mounting components at both ends **and** in the centre (if installed). Release the lock nuts of the stop screws. Adjust them as required and fix them with lock nuts again. Then push the sliding table against the stop screws and re-tighten all fastening screws.

#### Rip fence

##### Check:

Set the saw blade to maximum cutting height, and cut off a test piece of about 300 x 450 mm (if possible MDF) at the rip fence. The sound of the rising teeth must be the same as when cutting free on the left, with the sliding table correctly set.

##### Cross-check:

Move the rip fence approx. 0.5 mm closer to the saw blade, push the riving knife with the workpiece slightly to the side and cut in backward approx. 50 – 80 mm. Pull out again in the normal direction, turn it once around the cross-axis, and cut in approx. 20 mm deep in the normal way. The difference between these two cuts should be almost invisible but easily felt.

When using a scorer, make sure that both free cuts are set as equal as possible!

### Setting: Manually adjustable rip fence

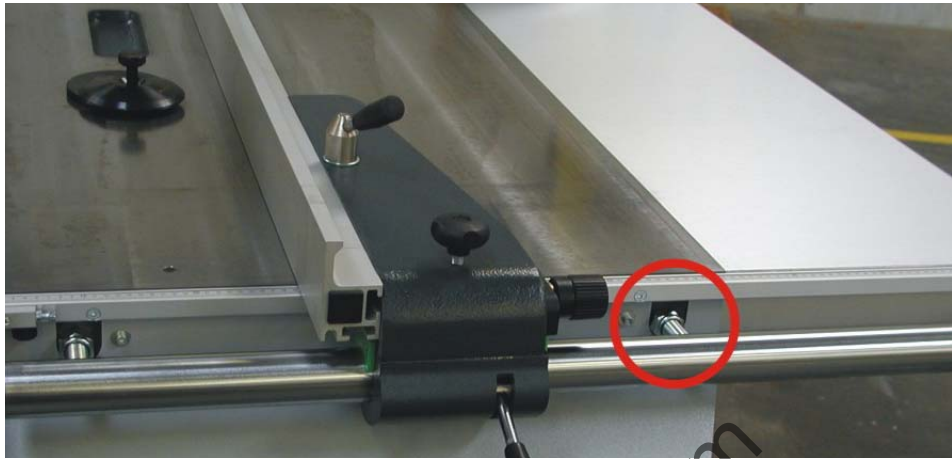

Fig. 5-45 Setting free cuts, standard rip fence

- Undo the nuts on the bolts connecting the round bar and the table width extension
- The degree of free cut on the rip fence can be altered by adjusting the middle lock nuts
- Tighten the nuts on the bolts connecting the round bar and the table width extension

### Setting: Electromotive rip fence

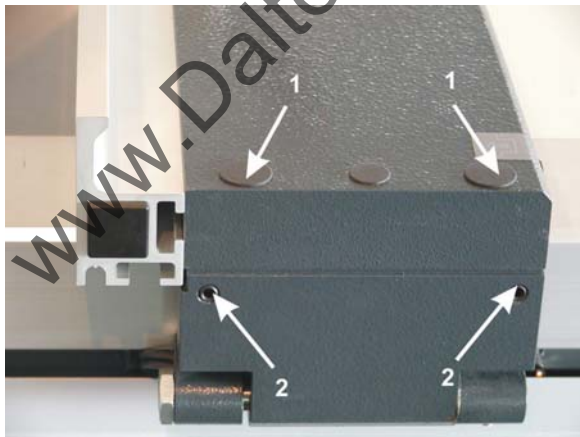

Fig. 5-46 Free cut setting, electromotive PA

- Release clamping screws 1
- Set the free cut by adjusting setscrews 2
- Tighten clamping screws 1

## 5 Transport, siting and installation

### 5.4.6 Angle cut

#### Checking the angle cut

Before checking the angle cut, check the settings of the sliding table and of the swinging arm, and correct them if necessary.

Carry out the check as follows:

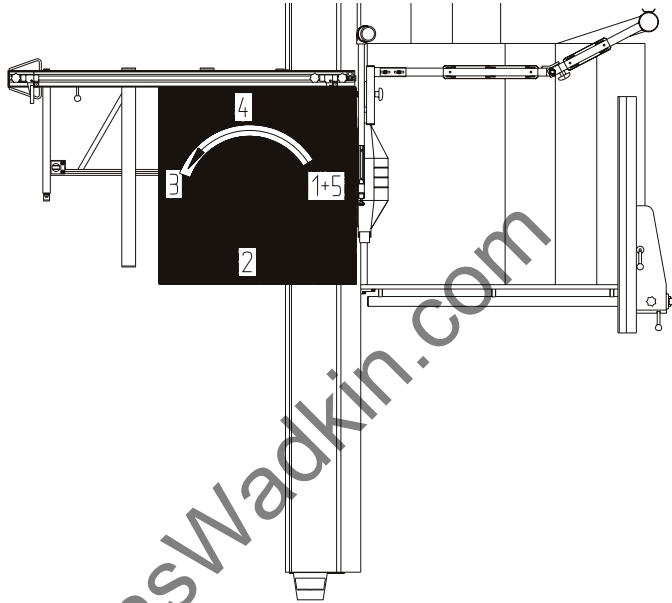

Fig. 5-47 Angle cut

As the tool, use a sharp saw blade,  $D = 350 \text{ mm}$  / 3.5/2.5/72 teeth alternate bevel at  $n = 5000 \text{ rpm}$ . Take a  $1000 \times 1000 \text{ mm}$  chipboard or MDF board, minimum board thickness  $19 \text{ mm}$ . Perform 5 cuts (see fig.), laying the last cut side at the crosscut fence for the next cut (turn the board counterclockwise). For the 5th cut, cut off a strip with a width of approx.  $10 \text{ mm}$ . Measure the thickness at both ends of the strip with a vernier caliper. The difference between the two dimensions divided by 4 gives the angular error per metre cut length.

Check:

The angle cut must be checked at a minimum of 2 different positions on the cross-slide of the sliding table.

Factory setting:

The cross-slide is clamped to positions of approx.  $300 \text{ mm}$  and  $1300 \text{ mm}$  from the sliding table end. In these two positions, the angle cut is checked and adjusted as described above. Ensure that the setting does not exceed the maximum permissible tolerance of  $< 0.2 \text{ mm}$  (for the 5th cut (dimension 1 - dimension 2)).

### 5.4.7 0° setting of the saw blade

**Check:**

- Set the tilt adjustment to 0°.
- Position 2 strips (approx. 100 mm wide) **vertically** in front of the crosscut fence, cut in this position and butt the cut surfaces against each other.
- If the setting is correct, the cut surfaces should be parallel, i.e. no gap can be seen between the cut surfaces.



Fig. 5-48 Cutting a test piece



Fig. 5-49 Checking the 0° -setting

**Setting:**

Recalibrate the machine if a gap is detectable!

## 6 Operating

### 6 Operating

#### 6.1 Working safely with the dimension saw

##### 6.1.1 Cross-slide/crosscut fence



Fig. 6-1 Cutting boards

The crosscut fence can be installed at two positions on the cross-slide.

##### **Position 1: Cutting boards**

The operator presses the workpiece against the fence in the cutting direction.



Fig. 6-2 Cutting solid wood

##### **Position 2: Cutting solid wood and boards up to 600 mm wide**

The operator pulls the workpiece along the fence against the cutting direction.

### Function description of the crosscut-mitre fence

- The crosscut-mitre fence can be swung by 49° (angle indicated on scale), plus angle-dependent adjustable length compensation via a scale.
- Ball bearings run in the sliding table groove, preventing the stop fence coming into the cutting plane when swung
- Clamping of the stop profile at the pivot and on the degree scale
- Additional clamping at the 90° position
- Movable, fixable C profile as an additional workpiece support

### Operating elements



Fig. 6-3 Position of clamping screws

- [1] Clamping screw 1  
[2] Clamping screw 2

### Adjusting the angle

- Release the clamping screws
- Set the crosscut-mitre fence to the desired angle
- Carry out length compensation
- Tighten clamping screw 1
- Set and tighten clamping screw 2



### Length compensation

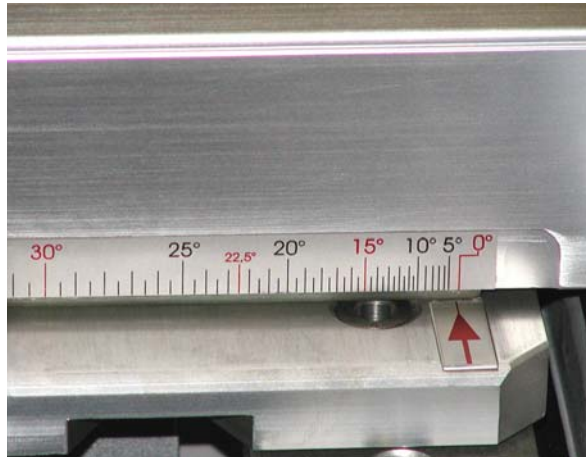

Fig. 6-4 Length compensation scale

By shifting the crosscut-mitre fence, the length dimension can be adjusted for the set angle.

#### Changing the crosscut-mitre fence

- Release the clamping screw and clamping lever
- Push the crosscut-mitre fence to the 2nd position
- Push the guide piece of the eccentric clamping system into the pivot groove as far as it will go and clamp it
- Tighten the clamping screws

#### Note!



When dimensions need to be adjusted with the stop bar, make sure that the flip stop is against the fence of the extension!



### 6.1.2 Rip fence



Fig. 6-5 Position of the clamping screw

For cutting parallel, the rip fence is pushed up to the required dimension. The set dimension is read off from the edge of the aluminium profile. The dimension scale can be adjusted to the individual tool thickness after releasing the knurled screw.

#### **Stop fences**



Fig. 6-6 Upright position of the stop fence

## 6 Operating

The stop fence of the rip fence can be adjusted in the cutting direction and to the profile height. Clamp it in the required position with the top eccentric lever. For crosscutting short workpieces and for recessing or other work cycles during which offcuts can become jammed between the stop and the saw blade, the stop fence is moved forward until its rear end is in front of the saw blade.

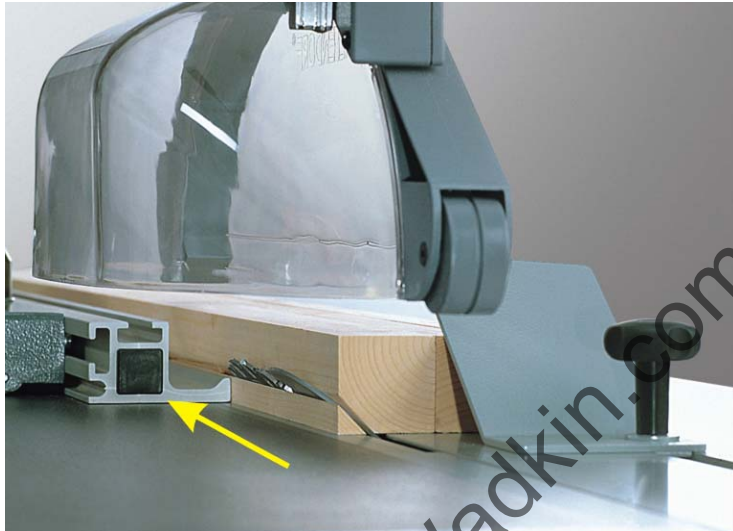

Fig. 6-7 Flat position of the stop fence

The stop fence is moved into the flat position when cutting flat and narrow workpieces. This means there is more space for workpiece guidance and the fence can be moved closer to the saw blade, in particular when the saw blade is tilted, without hitting the protection hood.



### Warning!

Danger of injury!

When cutting widths of less than 120 mm, make sure that the material is fed with a push stick and that the stop fence is laid flat.

### 6.1.3 Double roller carriage

Sliding table operating elements:



Fig. 6-8 Sliding table operating elements, manual



Fig. 6-9 Sliding table operating elements, TIP SERVO

## 6 Operating



Fig. 6-10 Sliding table operating elements, vacuum suction cups

The vacuum suction cups are exclusively operated by means of the operating panel.

## 6.2 Working examples

### General information

The Altendorf sliding table saw is a universal machine that can be used for various saw cuts. However, the machine must be set up appropriately.

### Tools

First, make sure that you only use saws in perfect condition, that the riving knife is correctly set and that the top protection hood is lowered close above the workpiece to be cut. The latter is also particularly important for ensuring perfect functioning of the top extraction system.

### Rotational speed

#### Note!



Make sure that the correct rotational speed is set and, after the machine has been switched on, do not start pushing the workpiece forward until the saw blade has reached its full rotational speed.

### Position of the hands

Lay your hands flat on the workpiece with fingers and thumbs close together, and with sufficient safety clearance from the saw blade.

For further information about safe working, refer to the following description of the individual work steps.

### Edge cutting (trimming)



Fig. 6-11 Edge cutting

*Tool: Circular saw blade for longitudinal cuts*

Work cycle: Fit the clamping shoe on the sliding table. Lay the workpiece with the hollow side down, and press underneath the clamping shoe. Push the workpiece forward by applying pressure with the ball of your right hand on the workpiece edge. Place your hands with sufficient safety clearance from the tool.



### Longitudinal cutting of narrow workpieces

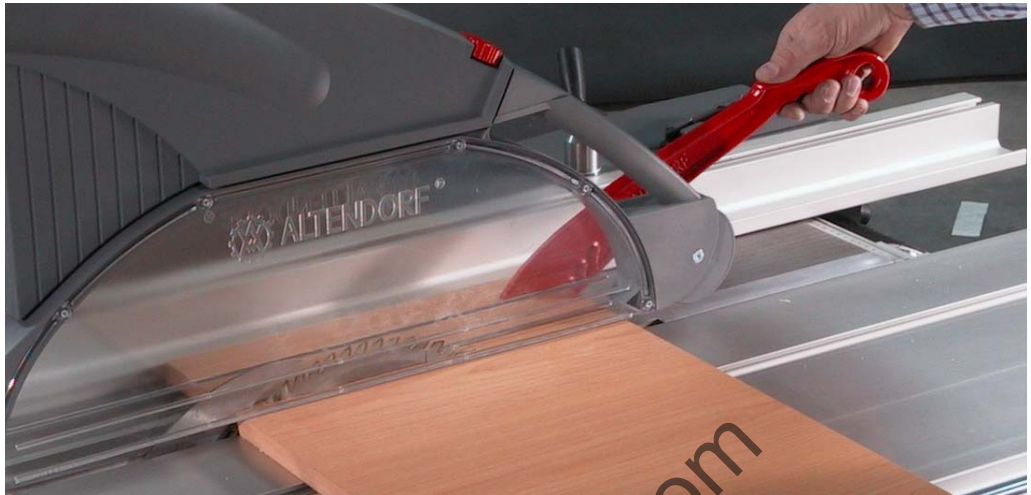

Fig. 6-12 Longitudinal cutting

Workpiece width < 120 mm

*Tool: Circular saw blade for longitudinal cuts*

Work cycle: Set the rip fence to the required cutting width. Lower the top protection hood according to the workpiece height. Push the workpiece (aligned along the fence) and sliding table forward, using the push stick in the vicinity of the saw blade, and push the parted workpiece beyond the riving knife. Use the push stick from the very beginning when cutting short workpieces.

### Cutting strips



Fig. 6-13 Cutting strips

*Tool: Circular saw blade for fine cuts*

## 6 Operating

Work cycle: Set the aluminium straight edge of the rip fence to the low guide surface. Lay the workpiece on the sliding table and press against the rip fence with your left hand. Push the workpiece forward with the sliding table; use the push stick in the vicinity of the saw blade to push the strip beyond the rising knife.

### Crosscutting wide workpieces



Fig. 6-14 Crosscutting

*Tool: Circular saw blade for crosscuts*

Work cycle: Lay the workpiece against the crosscut fence; when pushing forward, push firmly against the fence with your left hand. When using the throw-over stop, raise the stop and remove the workpiece from the saw blade before pulling back after the cut, or remove the workpiece behind the rising gear rim.



**Concealed cutting, rebating**

Fig. 6-15 Concealed cutting

*Tool: Circular saw blade for fine cuts*

Work cycle: When rebating, select the cutting sequence so that the cut-out strip is produced on the side of the blade opposite the fence. Lower the protection hood onto the workpiece and ensure good workpiece guidance (left hand presses the workpiece against the rip fence).

**Concealed cutting, grooves**

Fig. 6-16 Grooves

*Tool: Grooving tool permitted for manual feeding (max. width 20 mm)*

## 6 Operating

Work cycle: Close the table opening with a table strip matched to the grooving tool. Set the tool to the required groove depth. Leave the riving knife in as a rear tool cover. When pushing forward, firmly press the workpiece onto the table (otherwise danger of unintentional insert operation.).

### Note!



Always use the crosscut fence when cross-grooving narrow workpieces.

### Crosscutting against the rip fence



Fig. 6-17 Crosscutting

Lay the material against the crosscut fence of the cross-slide. Set the required dimension at the rip fence, pulling back the stop fence to the front of the saw blade after releasing the clamping, and guide the workpiece with the sliding table. When the stop fence is pulled back, the workpiece cannot jam between the saw blade and fence.

### Crosscutting short and narrow workpieces

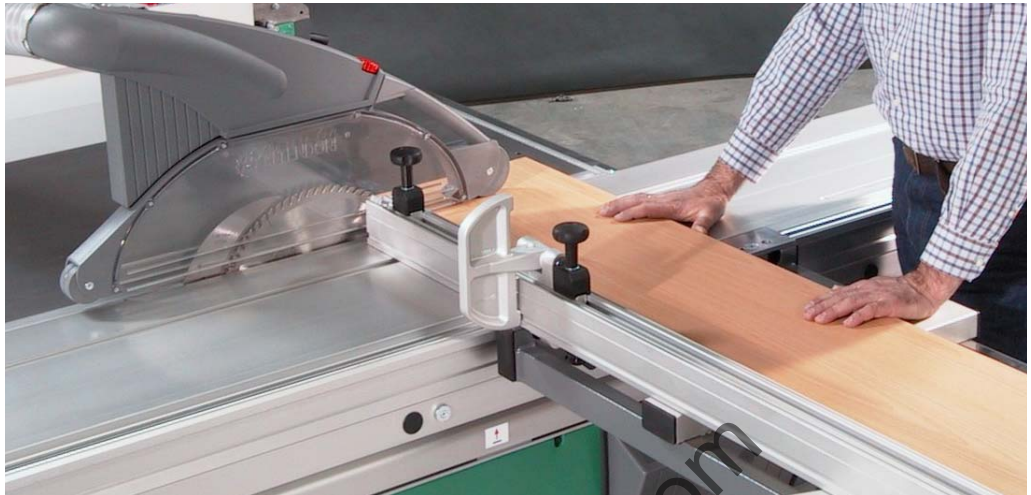

Fig. 6-18 Crosscutting

*Tool: Circular saw blade for fine cuts*

Work cycle: Adjust the deflector wedge featuring a magnet (not part of the scope of supply) such that the workpiece cuts cannot touch the rising section of the saw blade. Only feed workpieces using the crosscut fence. Never remove off-cuts by hand from the vicinity of the tool.

### Dividing large boards



Fig. 6-19 Dividing

For this work cycle, the dimension can be set both on the rip fence and on the crosscut fence. If several pieces of the same size are to be cut from a large board, it is best to first cut off parallel strips at the rip fence and then cut them to the required dimension. However, if the workpieces exceed the cutting width of the machine, the dimension is set at the machine's crosscut fence.

### Cutting with a negative cutting angle



Fig. 6-20 Cutting with a negative angle

For this work cycle only the crosscut fence or crosscut-mitre fence is used.

Do **not** use a DUPLEX fence!

Do not use a clamping shoe as the saw blade is tilted above the sliding table for a negative cutting angle.

## 6.3 Machine operation

### 6.3.1 Main switch



Fig. 6-21 Main switch

The main switch is located on the outside of the RH switch cabinet.

Before turning on the saw drives, the main switch must be moved to setting I. The machine control unit carries out a self-test, after which the available axes and their current values are displayed.

#### ***Grey/black main switch***

The main switch does not have an EMERGENCY STOP function! When the machine is turned off with the main switch, the saw drives run down unbraked!

#### ***Red/yellow main switch***

The main switch has an EMERGENCY STOP function! When the machine is turned off at the main switch, the main saw drive is braked.



### 6.3.2 Switching the saw drives on and off



Fig. 6-22 Switches for saw drives



#### Warning!

- Before switching on the machine, make sure that all protective devices required for the respective work cycle are attached and operative. In addition, check that the saw blades are correctly fitted and that there are no workpieces or other objects in their vicinity. Check whether the correct rotational speed has been preselected to match the saw blade and the work cycle to be performed. Check that the circular saw blade is running in the correct direction by briefly switching on.
- Make sure that the extraction system switches on at the same time as the saw drives.

Press the white push button I with the main saw symbol in the operating panel to start the main saw drive. After switching on the main saw, this button is lit. The scoring saw can only be started when the main saw has reached its operating speed. To do so, press the white push button I with the symbol of the scoring saw. This button lights up when the scoring saw has been switched on. To switch off, press the black button marked "O".



Fig. 6-23 Switches for sliding table saw drives

The drives can also be turned on and off with the switches on the sliding table (option).

In addition, the machine can be switched off with one of the EMERGENCY STOP buttons. However, this possibility should only be used in case of an emergency.



### 6.3.3 Setting the speed

Three rotational speeds can be set for the main saw drive by moving over the V-ribbed belt:

- 3000 / 4000 / 5000 rpm

#### *Changing the rotational speed*

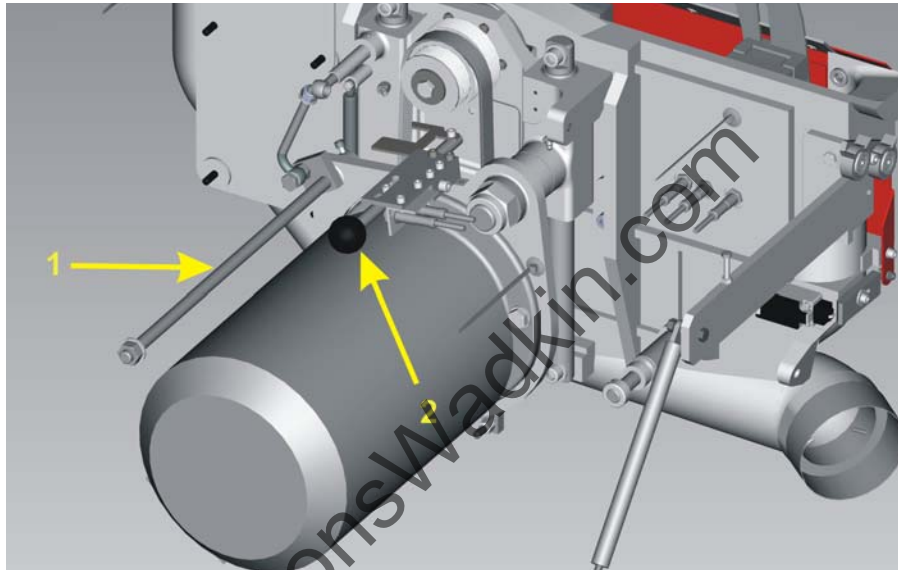

Fig. 6-24 Changing the rotational speed

- [1] Switch off the drive.
- [2] Open the machine door.
- [3] Turn screw 1 counterclockwise until it engages.
- [4] Set belt guide 2 to the required rotational speed.
- [5] Place the V-ribbed belt so that it runs in the recess of the belt guide and into the vertical opposite grooves of the belt pulley.
- [6] Turn screw 1 clockwise.

The belt tension is automatically set when the screw is turned back!

***A rotational speed of only 3000 rpm is permissible with a saw blade diameter of  $D = 550$  mm (only for machines without scoring unit), for VARIO 3500 rpm.***

***Optimum position for changing speed/belt: Tilt saw unit to 25°!***

### 6.3.4 Fitting the main saw blade

#### AKE clamping system



#### Warning!

The following points must always be observed:

Non-adherence may lead to severe injuries!

- Do not fit any saw blades that are cracked or damaged in any way.
- Only fit saw blades with a diameter between 250 and 550 mm. Machines with a scoring unit have a maximum saw blade diameter of only 500 mm!
- The maximum rotational speed  $n_{max}$  stated on the tool must not be exceeded.



Fig. 6-25 Front flange

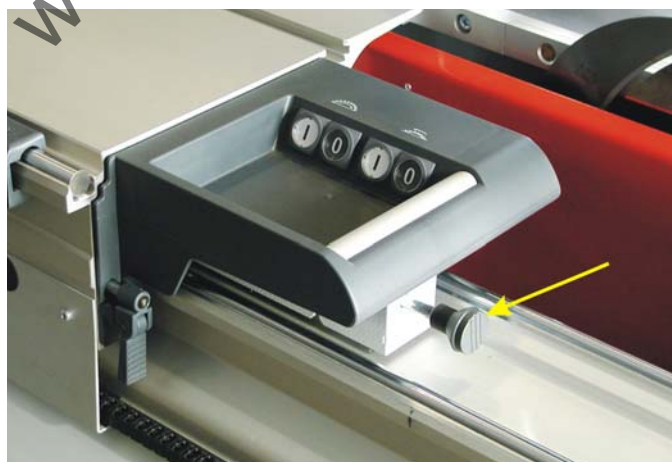

Fig. 6-26 Lock on the middle carriage

## 6 Operating

---

1. Switch off the drive.
2. Set the saw blade to the maximum cutting height and tilt to 0°.
3. **Turn off the main switch.**
4. Move the top carriage to the middle of the saw shaft, and unlock the lock at the saw blade centre by pressing the knob on the middle carriage.
5. Move the top carriage to the end position in the cutting direction.
6. Raise the red cover plate.
7. Use the wrench to release the screw in the expansion-head screw.
8. Undo the expansion-head screw by turning it counterclockwise with the flange.
9. Before fitting the new saw blade, remove any adhering chips and dust from both flanges.
10. Place the saw blade and front flange onto the saw shaft, turn in the expansion-head screw by hand and tighten it with the wrench.
11. Check the riving knife for strength and distance from the saw blade.
12. Close the red protective cover and perform a short test run to see whether the saw blade is running freely. Do this by lowering the top protection hood down to the table so that the saw blade is completely covered.



---

### Warning!

Check that saw blade clamping system is tight before operating the machine!

---

### Fitting a milling tool

In order to use a milling tool (max. cutting width 20mm), first proceed as described in point 1-8 in the previous section.

Then proceed as follows:

1. Remove the riving knife, cushioning disc and screws in the centre table strip

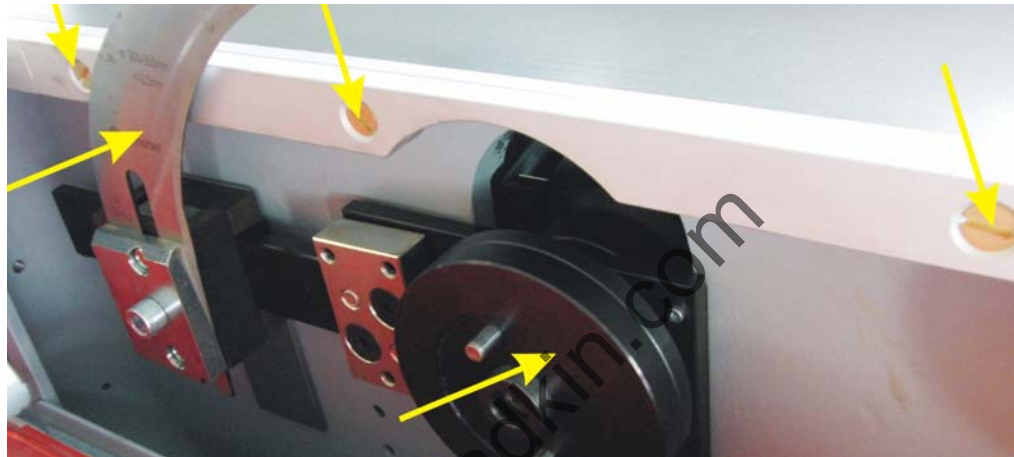

Fig. 6-27 See point 1

2. Remove the front part of the centre table strip
3. Place the milling cutter and front flange onto the saw shaft, turn in the expansion-head screw by hand and tighten it with the wrench.
4. Retract the riving knife block completely and tighten the clamping screw of the riving knife holding fixture
5. Close the red protective cover and perform a short test run to see whether the milling cutter is running freely. Do this by lowering the top protection hood down to the table so that the milling cutter is completely covered.



### Warning!

When returning to normal processing with a saw blade, adhere to the following:

Non-adherence to these points may lead to severe injuries of the operator!

- Reinsert the disassembled centre table strip; only use original brass screws for fastening
- Reinstall the cushioning disc
- Reinstall and correctly adjust the riving knife

## 6 Operating



### Warning!

After changing a saw blade, always check that the riving knife is correctly set.

Non-adherence to these points may lead to severe injuries of the operator!

- Select the riving knife according to the saw blade size and main blade thickness
- Ensure that the riving knife thickness is min. 0.2 mm larger than the main blade thickness
- The distance of the riving knife from the gear rim must be between 3 mm and 8 mm.
- The highest point of the riving knife must be set to between 0 and -2 mm beneath the topmost tooth.
- The riving knife must be at least 0.2 mm thicker than the main saw blade.

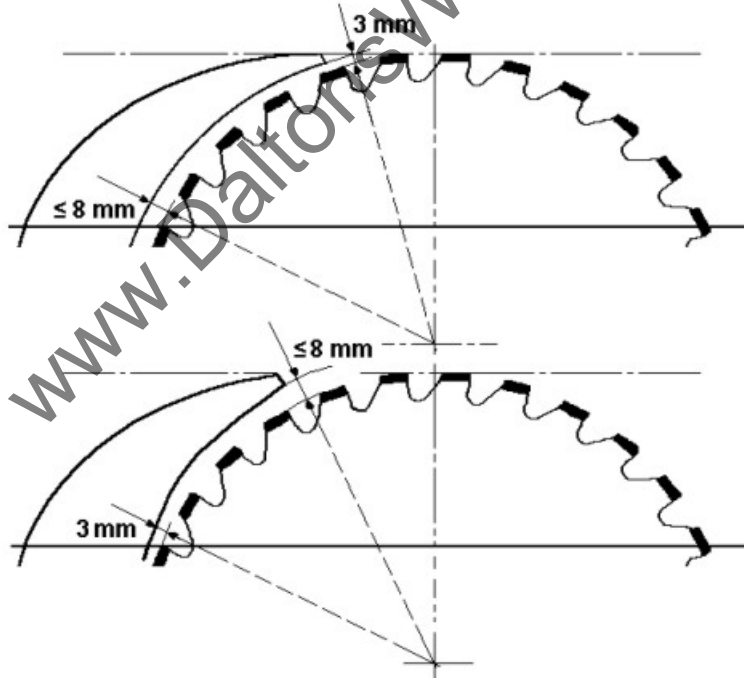

Fig. 6-28 Adjusting the riving knife

### 6.3.5 Saw blade recommendation



#### Warning!

Please note that only main saw blades with side holes can be fitted. This is necessary to prevent loosening of the saw blade mounting in the course of braking!

- Do not use high-speed steel (HSS) saw blades!
- The tools require a hole diameter of 30 mm and carrier holes of 10 mm diameter on a pitch circle diameter of 60 mm!
- The scoring blades have different diameters and are described in the respective chapters of this manual.

Choosing the correct saw blade in accordance with the material to be cut and its thickness, alongside the correct cutting speed, is very important for a clean cut and low stress for the operator. For a selection of saw blades for ALTENDORF sliding table saws, refer to the tool manufacturers' documentation. As some of the stated cutting speeds cover large ranges, it is indispensable to empirically determine the best speed for optimum cutting results!

Cutting speed in m/sec. for the adjustable rotational speeds and saw blade diameters:

Diameter [mm]	3000 rpm	4000 rpm	5000 rpm
250	39	52	65
300	47	63	79
350	55	73	92
400	63	84	105
450	71	94	118
500	80	106	132
550	86	115	144

Tbl. 6-1 Cutting speed

The areas marked grey may not be adjusted!

## 6 Operating

### 6.3.6 Table locking

The sliding table interlock can lock the sliding table in any position, so that the workpiece can be pushed against the crosscut fence without the easy-running sliding table being set in motion unintentionally. It is actuated by means of a handle at the end of the top carriage.



Fig. 6-29 Sliding table unlocked



Fig. 6-30 Sliding table locked



## 6.4 Monitor controls EvoDrive



Fig. 6-31 Monitor controls EvoDrive

- [1] Return button: one step back
- [2] Home button: return to start screen
- [3] Menu button: Menu call-up

Make changes to the desired setting by pressing the respective symbol on the screen. Enter the dimensions via the numeric keypad and press the yellow START button to carry out positioning. The operation can be interrupted at any time by pressing the STOP button. Positioning is finished when the dimension display switches to green numbers.

**Note:**

It is also possible to change several axes in their dimension by confirming the values with the Enter key. Then press the START button to adjust them together.

**Infinitely variable fine adjustment** is possible by pressing the Plus or Minus button. Adjustment takes place in creep speed mode. Pressing the button for more than 3 seconds switches adjustment to rapid speed mode. Briefly touching the Plus or Minus button causes adjustment of 0.1 mm (0.1°).



---

**Attention!**

**Safety area**

- For cutting widths of less than 180 mm, the rip fence is in the safety area and it may only be possible to change the axes in inching mode, i.e. adjustment only takes place while the START button is pressed. Inching mode is indicated by a flashing START symbol at the top left of the display.
- 

www.DaltonsWadkin.com

### 6.4.1 Height adjustment



Fig. 6-32 Start screen

For height adjustment, touch the highlighted button, the following screen appears:



Fig. 6-33 Saw blade height adjustment

Changing the saw blade height:

- Select one of the 4 last values by touching it
- or
  - enter a new dimension
  - Change the dimension by means of the plus or minus button
- Confirm the entry by pressing ENTER; the following screen appears:

## 6 Operating

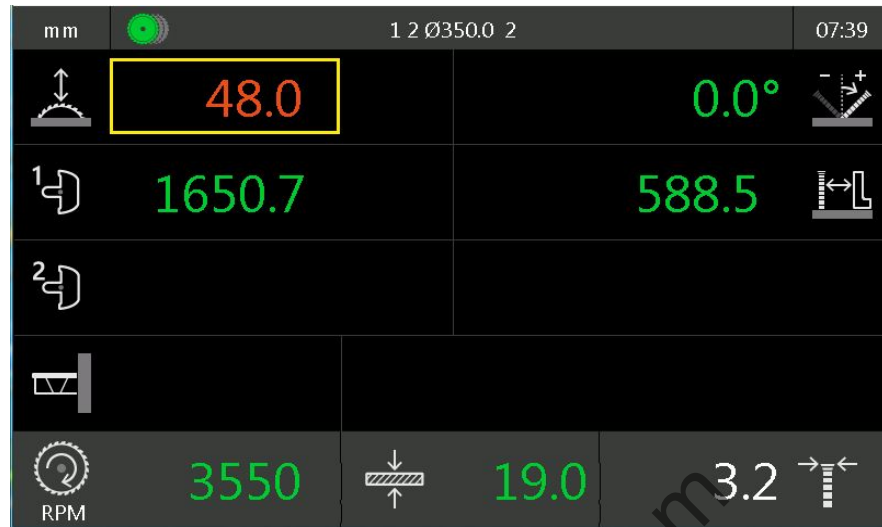

Fig. 6-34 Saw blade height adjustment

After pressing the yellow start button, the dimension field loses its colour and the value is displayed in green once the position is reached.

## 6.4.2 Tilt adjustment

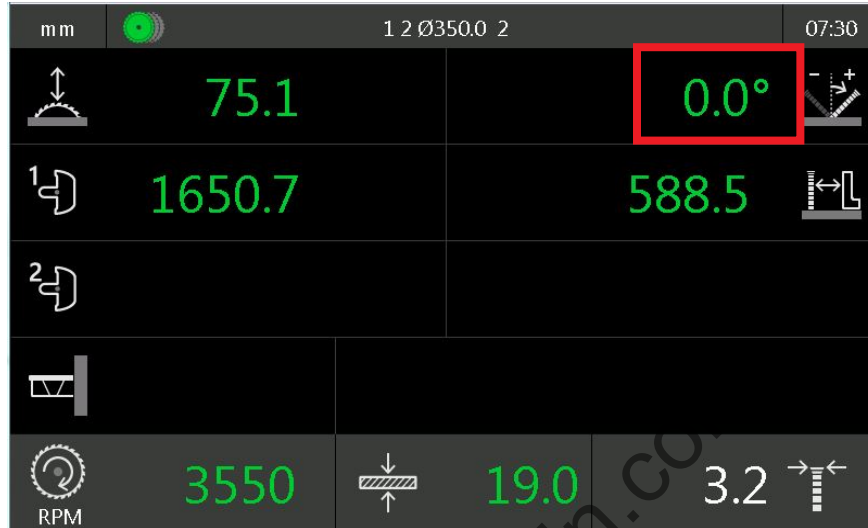

Fig. 6-35 Start screen



### Warning!

Always observe the following points prior to tilting the saw blade:

- Use the wide safety hood!
- When tilting to negative angles, laterally adjust the protective hood!
- Clear the main table of any workpieces in the swivelling area.
- When cutting widths less than 180 mm, set the rip fence straight edge to the flat position.
- When the tilt has been adjusted, the cutting height that has been set is automatically set to its value. Collisions can occur if the above points are not followed!
- In case of large cutting heights, the selected cutting height may be impossible to reach when swivelling.

For tilt adjustment, touch the highlighted button, the following screen appears:

6 Operating

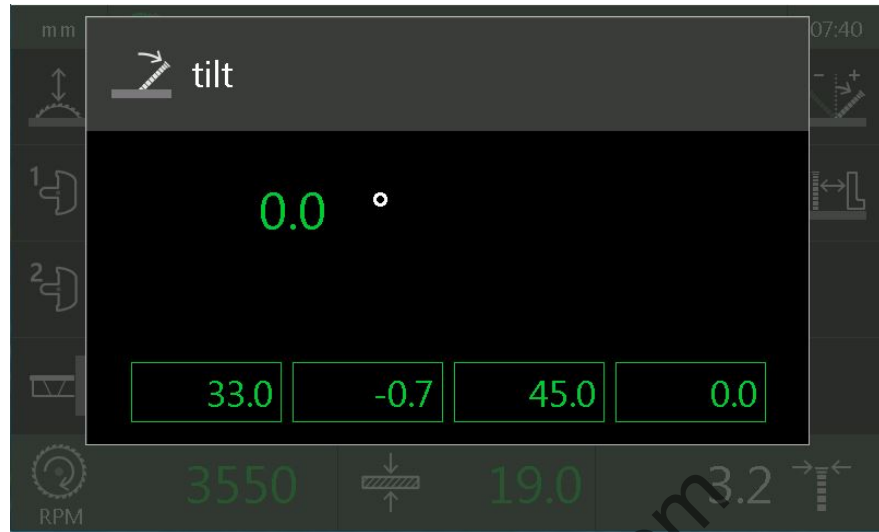

Fig. 6-36 Tilt adjustment

**Note!**



When the saw blade is tilted, the dimensions of the rip fence and crosscut fence may change. This is due to the tilt axis correction and the obtuse angle/acute angle setting of the rip fence or crosscut fence.

- For CNC axes, the correction is made automatically.
- For manually adjustable axes, workpiece dimensions can be entered. The fence dimensions to be set manually are then displayed.
- If no correction is necessary, no value is displayed



Fig. 6-37 Display of the auxiliary dimensions of the tilted saw blade

Auxiliary dimension crosscut fence \_\_\_\_\_ auxiliary dimension rip fence

### Changing the tilting angle

- Select one of the 4 last values by touching it
- or
  - enter a new dimension
  - Change the dimension by means of the plus or minus button
- Confirm the entry by pressing ENTER; the following screen appears:

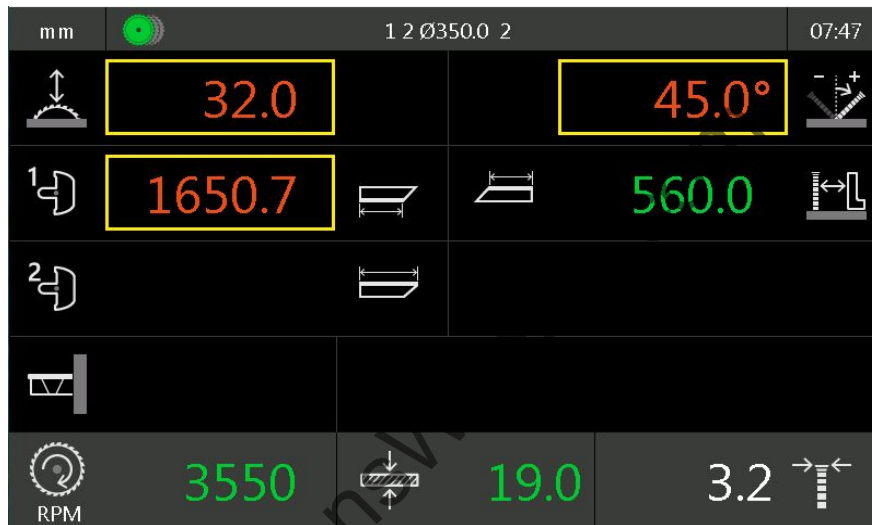

Fig. 6-38 Tilt adjustment

After pressing the yellow start button, the dimension field loses its colour and the value is displayed in green once the position is reached. The saw blade height and CNC crosscut fence (if installed) are also corrected.

### Calibration

- Select tilting.
- Press the Cal button for >1sec., CAL is displayed.
- Enter the measured tilt angle via the numeric keypad.
- Press the Cal button; the new tilt angle is shown on the display.



## 6 Operating

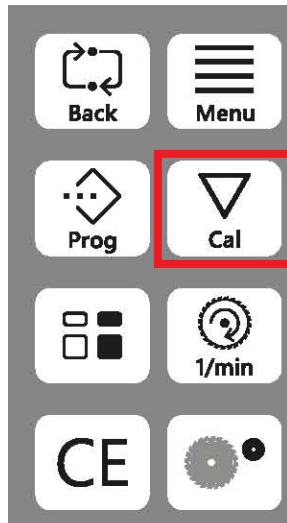

Fig. 6-39 Function button block

***Infinitely variable fine adjustment*** is possible by pressing the Plus or Minus button. Adjustment takes place in creep speed mode. Pressing the button for more than 3 seconds switches adjustment to rapid speed mode. Briefly touching the Plus or Minus button causes adjustment of 0.1 °.



### 6.4.3 Electromotive rip fence (option)

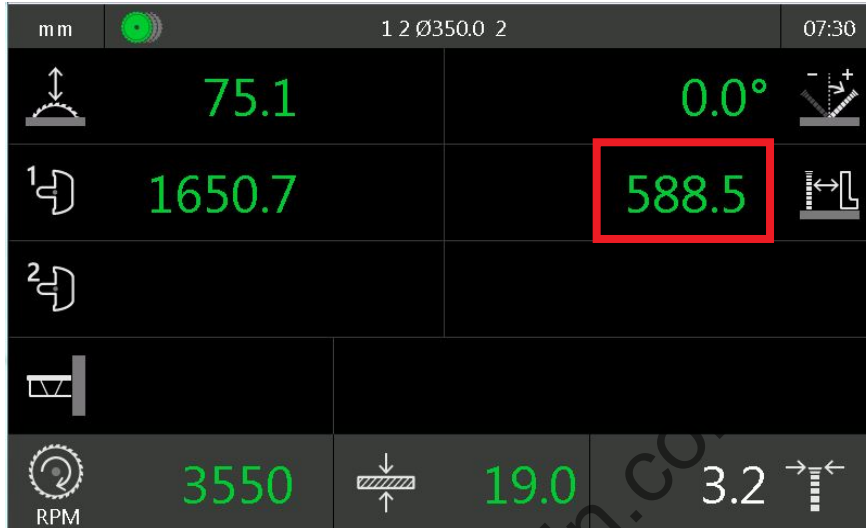

Fig. 6-40 Rip fence selection



#### Warning!

Prior to adjusting the rip fence, remove any workpieces/residual pieces from the adjustment area.

Non-adherence can lead to jamming between the fence and saw blade causing kick-backs and injury to the operator.

To adjust the CNC rip fence, touch the highlighted button, the following screen appears:



Fig. 6-41 Rip fence adjustment

## 6 Operating

Changing the rip fence:

- Select one of the 4 last values by touching it
- or
  - enter a new dimension
  - Change the dimension by means of the plus or minus button
- Select the acute or obtuse angle
- Confirm the entry by pressing ENTER; the following screen appears:

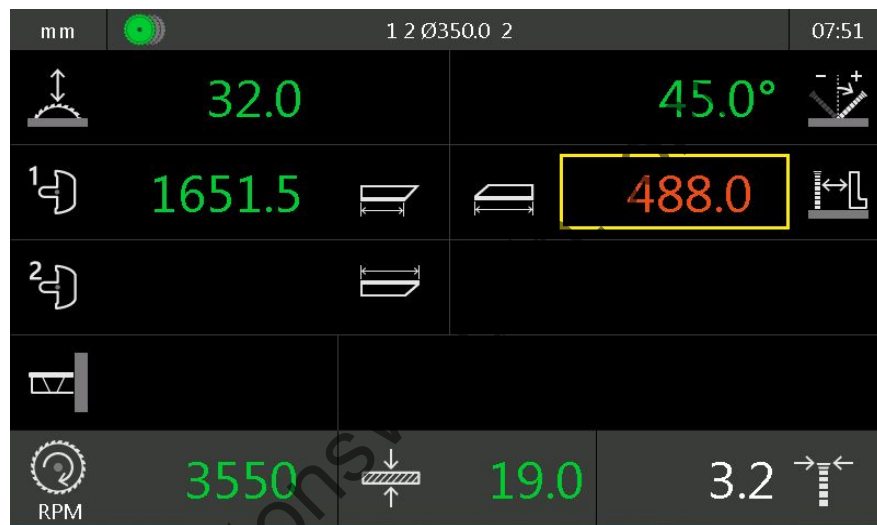
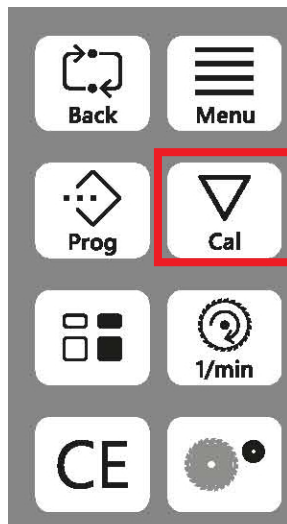

Fig. 6-42 Rip fence adjustment

After pressing the yellow start button, the dimension field loses its colour and the value is displayed in green once the position is reached.

### Calibration

- Select rip fence.
- Press the Cal button for >1sec., CAL is displayed.
- Enter the measured cutting width via the numeric keypad.
- Press the Cal button; the new cutting width is shown on the display.



**Infinitely variable fine adjustment** is possible by pressing the Plus or Minus button. Adjustment takes place in creep speed mode. Pressing the button for more than 3 seconds switches adjustment to rapid speed mode. Briefly touching the Plus or Minus button causes adjustment of 0.1 mm.



## 6 Operating

### 6.4.4 Infinitely variable speed adjustment (option)

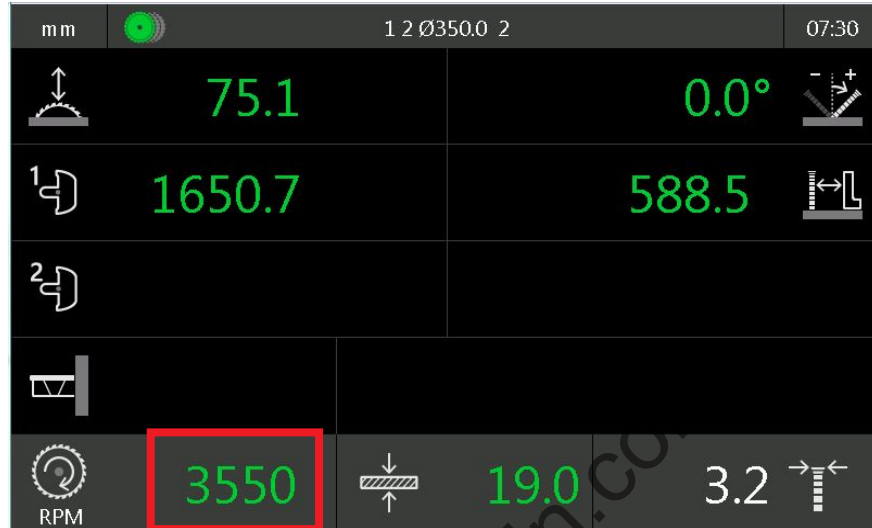

Fig. 6-43 Start screen

To adjust the rotational speed, touch the highlighted button, the following screen appears:



Fig. 6-44 Rotational speed adjustment

Changing the rotational speed

- Select one of the 4 last values by touching it or
- Tap the large numerical value and change it by entering numbers
- Use the plus or minus button to change the rotational speed by 50 revolutions each



Fig. 6-45 Rotational speed adjustment

If tool management is active, the cutting speed in m/sec is also displayed. Once you have pressed the start button, the start screen with the changed rotational speed appears.

## 6 Operating

### 6.4.5 CNC crosscut fence

#### CNC crosscut fence DUO



Fig. 6-46 CNC crosscut fence UNO

To adjust the crosscut fence, touch the highlighted button, the following screen appears:



Fig. 6-47 Dimension input



### Changing the crosscut fence

- Select one of the 4 last values by touching it
- or
  - enter a new dimension
  - Change the dimension by means of the plus or minus button
- Select the acute or obtuse angle
- Confirm the entry by pressing ENTER; the following screen appears:

Once you press the yellow START button, the dimension field changes colours. The value is displayed in green once the position is reached.

If a manual rip fence is equipped, the correction values for the crosscut fence are displayed as a function of the tilt angle.

#### Note!



Additional input options for dimension input.

- Use the P button to move the 2nd throw-over stop to the minimum position
- If the PIN button is activated, the input window remains open. The fence can then quickly be moved between different positions.

## 6 Operating

### Calibration

- Select crosscut fence.
- Press the Cal button for >1sec., CAL is displayed.
- Enter the measured dimension via the numeric keypad.
- Press the Cal button; the new dimension is shown on the display.

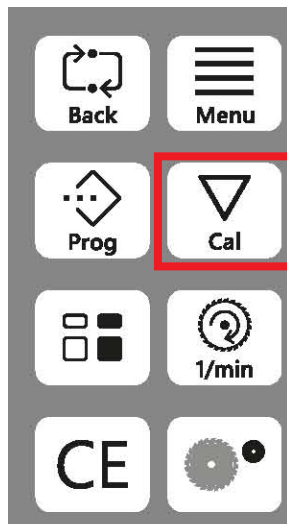

Fig. 6-48 Function button block

**Infinitely variable fine adjustment** is possible by pressing the Plus or Minus button. Adjustment takes place in creep speed mode. Pressing the button for more than 3 seconds switches adjustment to rapid speed mode. Briefly touching the Plus or Minus button causes adjustment of 0.1 mm.



### CNC crosscut fence DUO 90

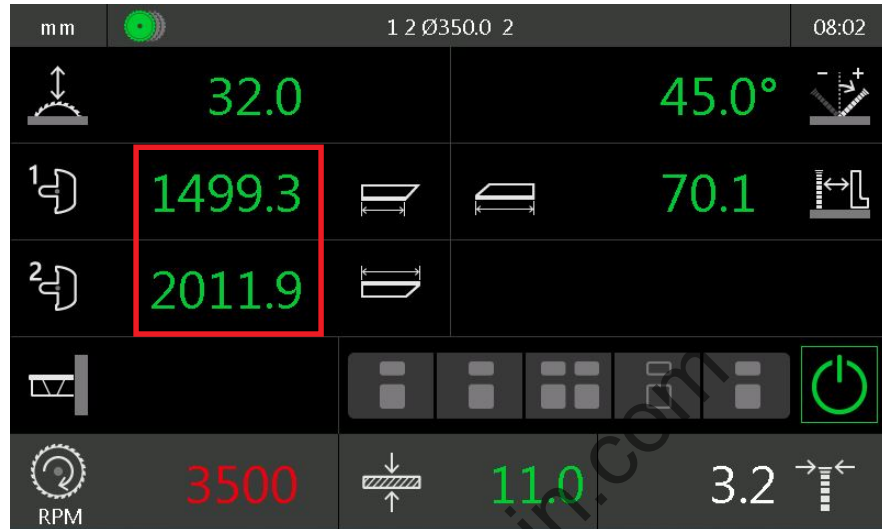

Fig. 6-49 CNC crosscut fence DUO90

To adjust the crosscut fence, touch one of the highlighted buttons, the following screen appears:

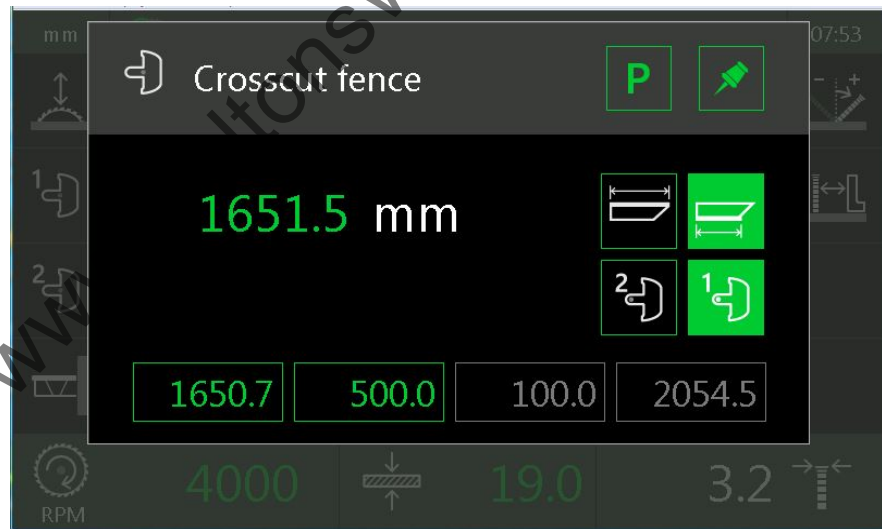

Fig. 6-50 Dimension input

Changing the crosscut fence:

- Select one of the 4 last values by touching it
- or
  - enter a new measurement (entered values are assigned to the throw-over stop which can reach this value.)
  - Change the measurement by means of the plus or minus button
- Select the acute or obtuse angle
- Complete the input with ENTER

Once you press the yellow START button, the dimension field changes colours. The value is displayed in green once the position is reached.

If a manual rip fence is equipped, the correction values for the crosscut fence are displayed as a function of the tilt angle.

**Note!**



Additional input options for dimension input:

- Use the P button to move the 2nd throw-over stop to the minimum position
- If the PIN button is activated, the input window remains open. The fence can then quickly be moved between different positions.

### Calibration

- Select crosscut fence.
- Press the Cal button for >1sec., CAL is displayed.
- Enter the measured dimension via the numeric keypad.
- Press the Cal button; the new dimension is shown on the display.

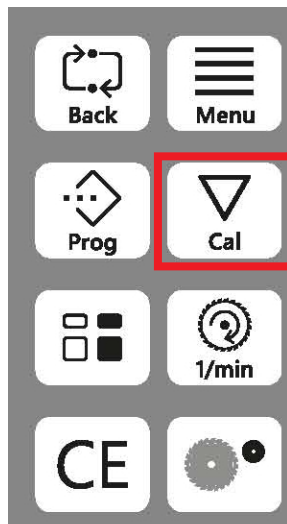

Fig. 6-51 Function button block

**Infinitely variable fine adjustment** is possible by pressing the Plus or Minus button. Adjustment takes place in creep speed mode. Pressing the button for more than 3 seconds switches adjustment to rapid speed mode. Briefly touching the Plus or Minus button causes adjustment of 0.1 mm.



**CNC crosscut-mitre fence DUO Flex**

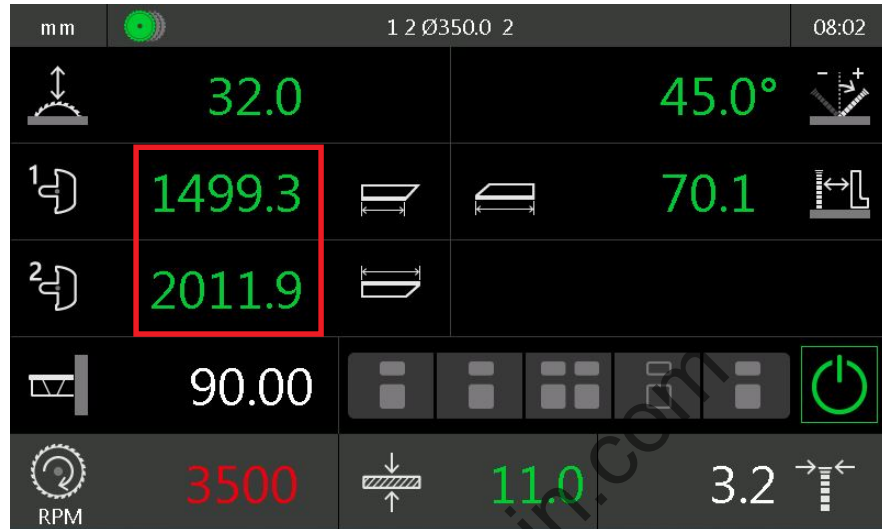

Fig. 6-52 CNC crosscut-mitre fence DUOFlex

To adjust the crosscut fence, touch one of the highlighted buttons, the following screen appears:



Fig. 6-53 Dimension input

### Changing the crosscut fence

- Select one of the 4 last values by touching it
- or
  - enter a new dimension (entered values are assigned to the throw-over stop which can reach this value.)
  - Change the dimension by means of the plus or minus button
- Select the acute or obtuse angle
- Complete the input with ENTER

Once you press the yellow START button, the dimension field changes colours. The value is displayed in green once the position is reached.

If a manual rip fence is equipped, the correction values for the crosscut fence are displayed as a function of the tilt angle.

#### Note!



Additional input options for dimension input:

- Use the P button to move the 2nd throw-over stop to the minimum position
- If the PIN button is activated, the input window remains open. The fence can then quickly be moved between different positions.

## 6 Operating

### Calibration

- Select crosscut fence.
- Press the Cal button for >1sec., CAL is displayed.
- Enter the measured dimension via the numeric keypad.
- Press the Cal button; the new dimension is shown on the display.

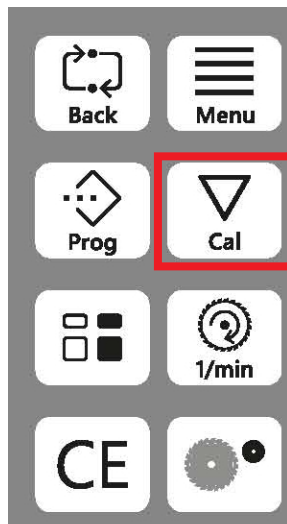

Fig. 6-54 Function button block

**Infinitely variable fine adjustment** is possible by pressing the Plus or Minus button. Adjustment takes place in creep speed mode. Pressing the button for more than 3 seconds switches adjustment to rapid speed mode. Briefly touching the Plus or Minus button causes adjustment of 0.1 mm.





### 6.4.6 Vacuum clamping in the sliding table

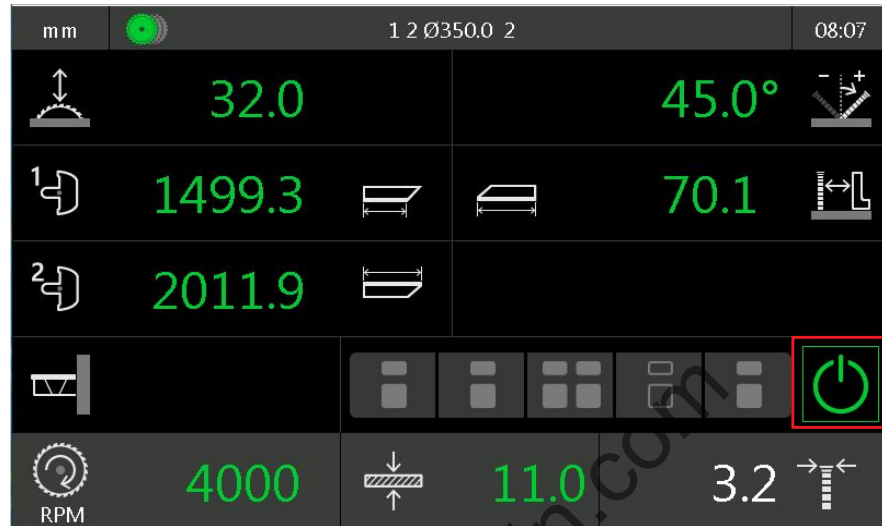

Fig. 6-55 Vacuum table

Press the highlighted button or use the remote control to draw in or release the workpiece. During intake, the button turns from grey to green.

#### Note!

If the option *Vacuum clamping in the sliding table* is selected, separate instructions are enclosed!



6 Operating

6.4.7 Menu

Grooves / concealed cuts

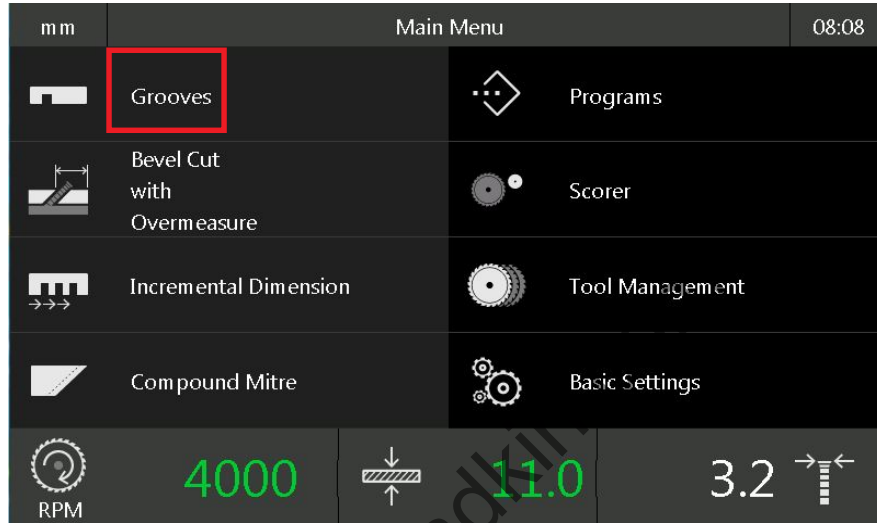

Fig. 6-56 Main menu

To call up the grooving function, touch the highlighted button, the following screen appears:

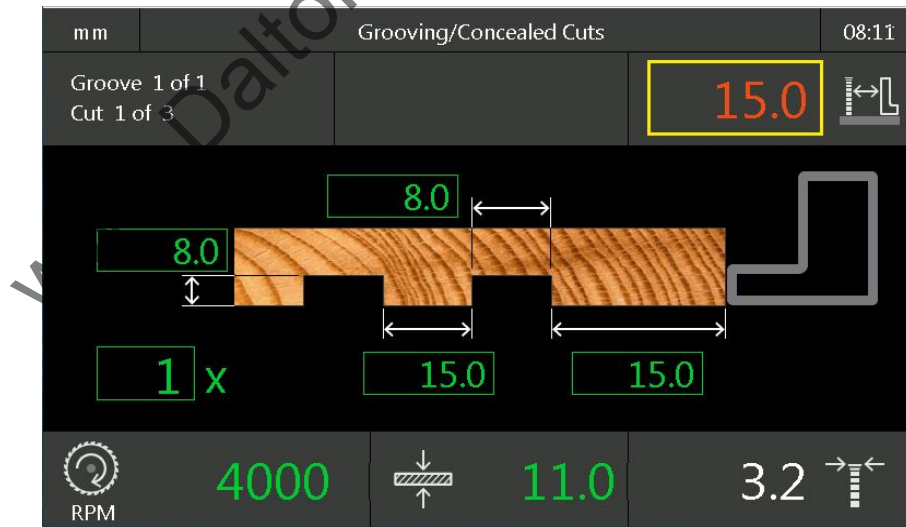

Fig. 6-57 Groove 1st cut

Enter the groove dimensions here. When the rip fence is in the start position, the first of 3 cuts can be carried out.

For the second cut, press the start button, the rip fence will move to its new position. Now the 2nd cut can be carried out.

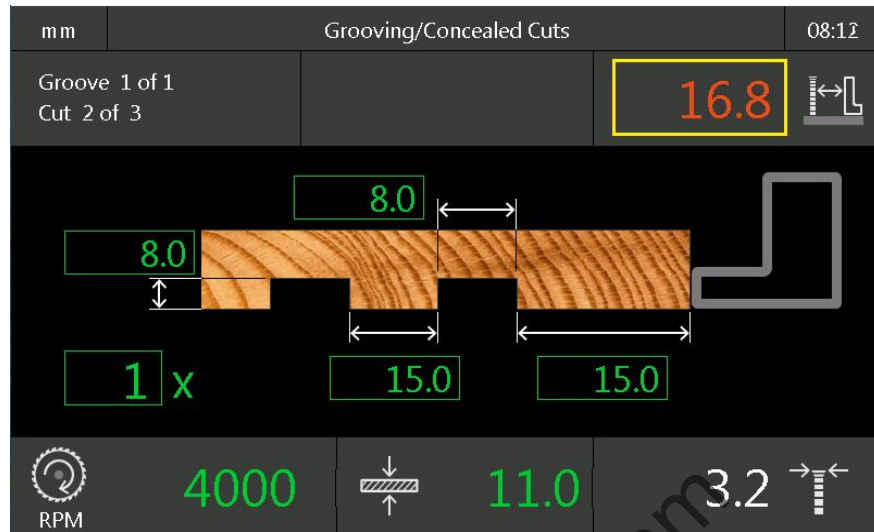

Fig. 6-58 Groove 2nd cut

For the third cut, press the start button, the rip fence will move to its new position. Now the third cut can be carried out.

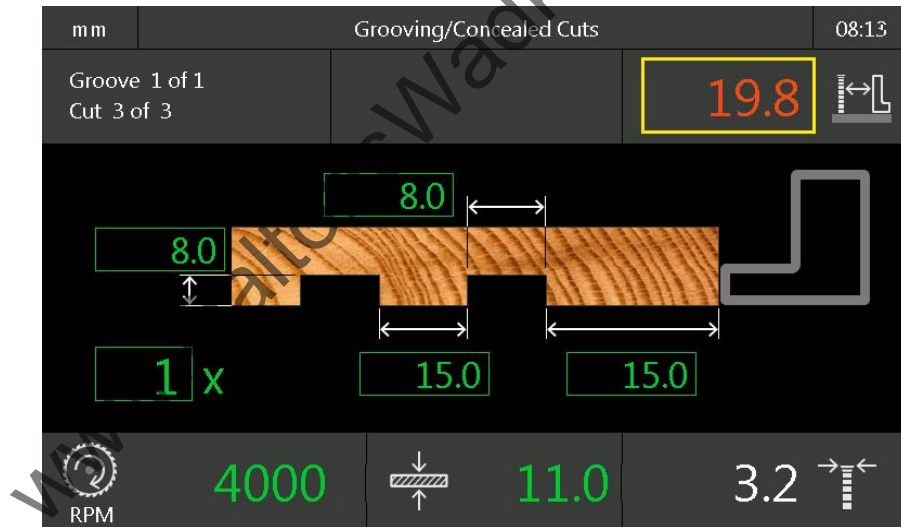

Fig. 6-59 Groove 3rd cut

The grooving process can be restarted by pressing the highlighted button.

## 6 Operating

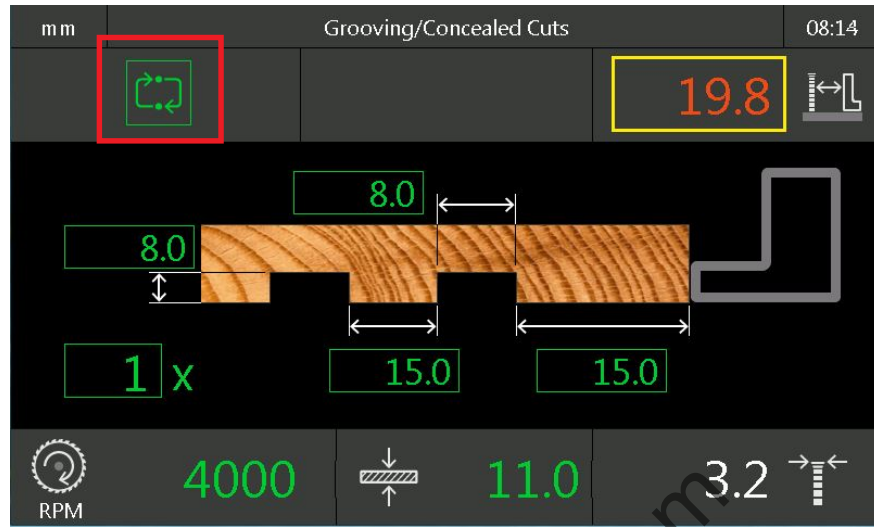

Fig. 6-60 Restart grooving process.

**Note!**



If the saw blade is in the vertical position, the current tilting angle is shown with a red background!

Touch the red field to select a tilting angle of 0°, so that the tilting angle is corrected during the 1st positioning.

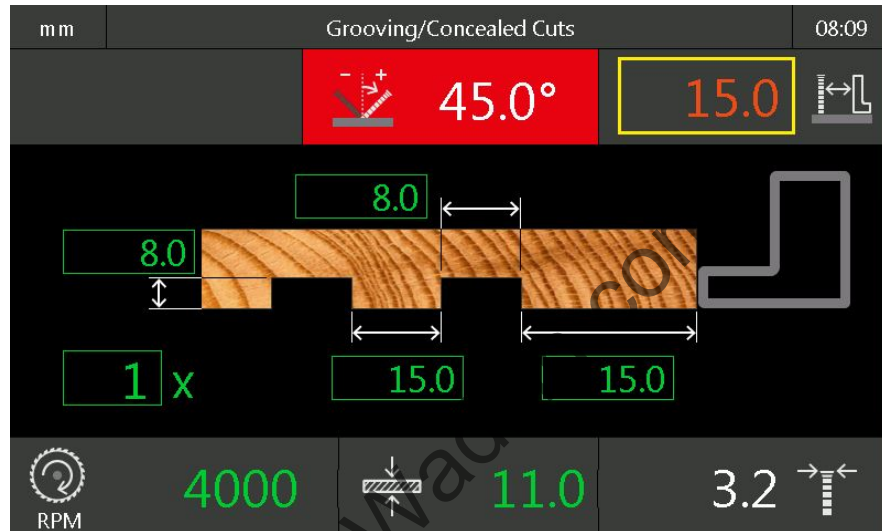

Fig. 6-61 Tilting angle deviating from 0°

**Angle cut with oversize**

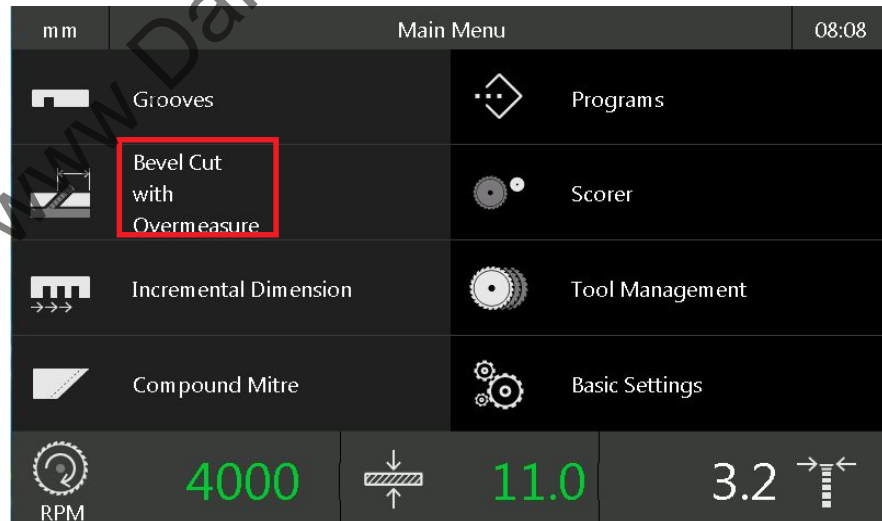

Fig. 6-62 Main menu

To call up the angle cut function, touch the highlighted button, the following screen appears:

## 6 Operating

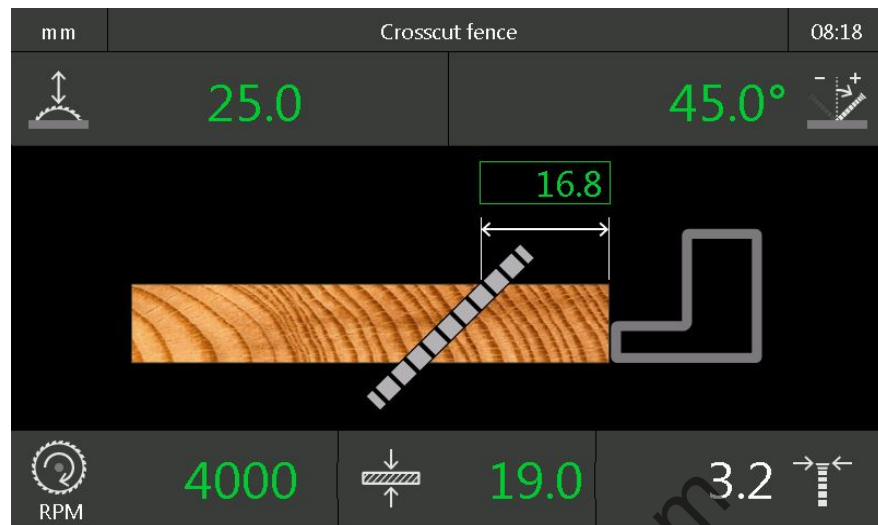

Fig. 6-63 Angle cut with oversize

The following values have to be entered:  
Enter the value after pressing the corresponding button!

- Workpiece oversize
- Workpiece thickness (measured)
- Saw blade overhang
- Tilt angle

**Note!**

- Correctly enter the saw blade thickness, otherwise the dimensions will be incorrect!

Please note that saw blades generally cut wider than the blade thickness indicated on the saw blade.



### Incremental dimensions

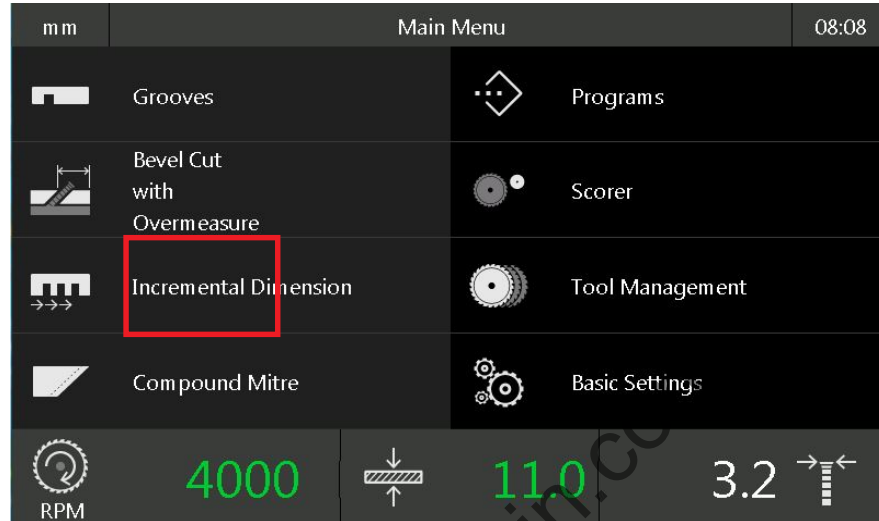

Fig. 6-64 Main menu

For work with incremental dimensions, touch the highlighted button, the following screen appears:

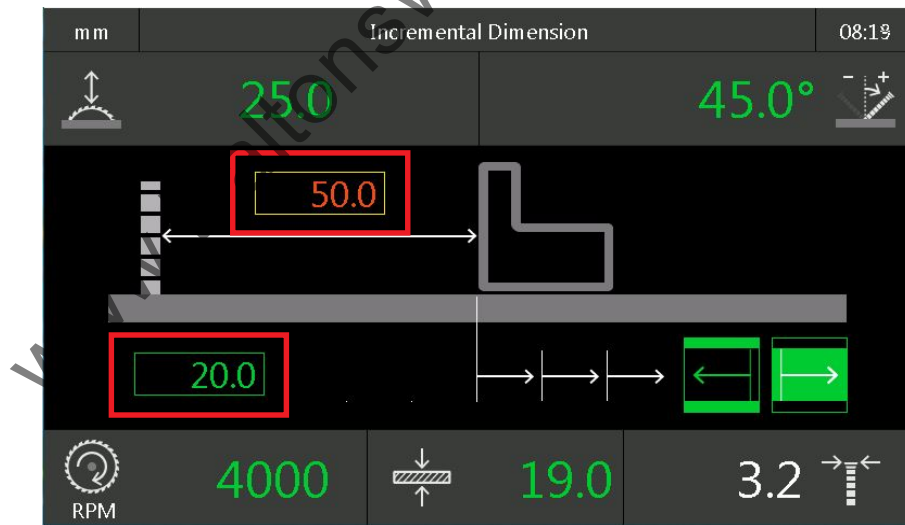

Fig. 6-65 Incremental dimensions

Incremental dimension \_\_\_\_\_ Start position

The saw blade height and the rip fence are not in the correct position. Once the start button is pressed, the following screen appears:

All axes are in the correct position and the incremental dimension work cycle can be started.

## 6 Operating

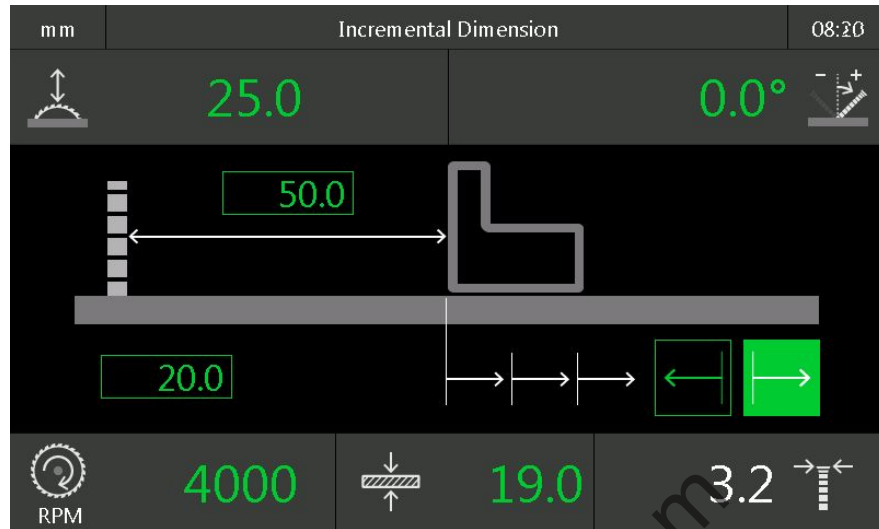

Fig. 6-66 Incremental dimensions

Once you have pressed the start button, the rip fence moves by 20 mm to higher values.

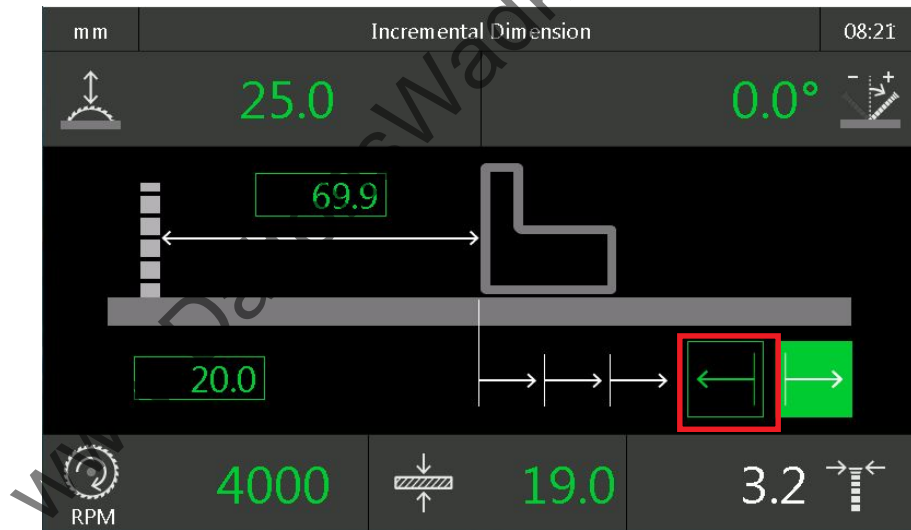

Fig. 6-67 Incremental dimensions

If a certain dimension is to be positioned from the start position in the direction of the saw blade, select this direction with the red button.



### Shifter cut

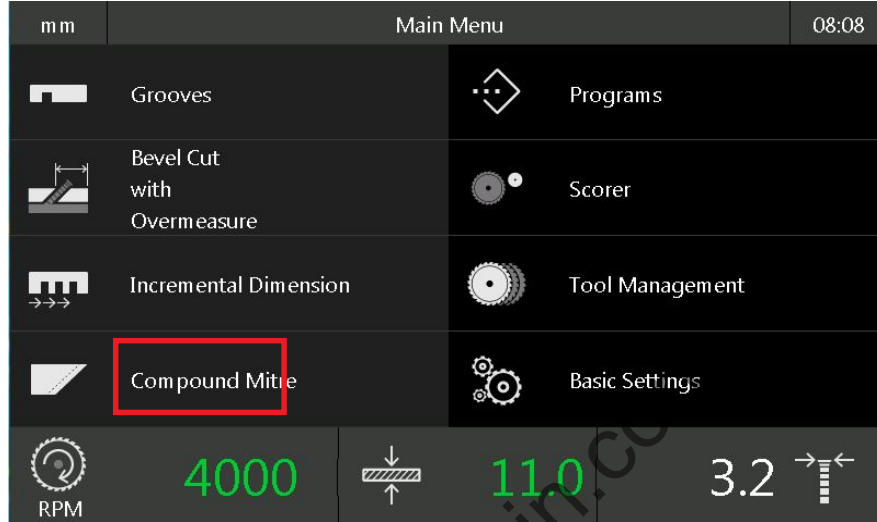

Fig. 6-68 Main menu

For the shifter cut function, touch the highlighted button, the following screen appears:

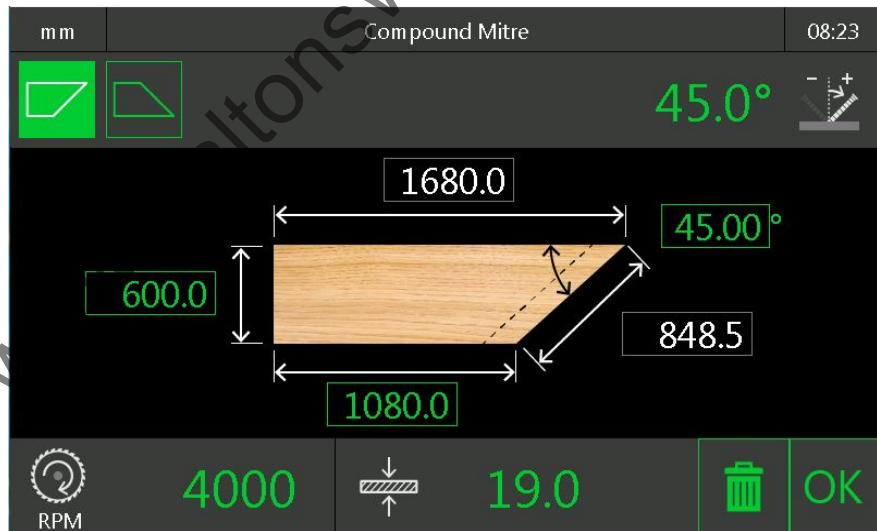

Fig. 6-69 Shifter cuts

The workpiece positioning and the setting of the crosscut-mitre fence is displayed once you press the OK button, see the following screen:

6 Operating

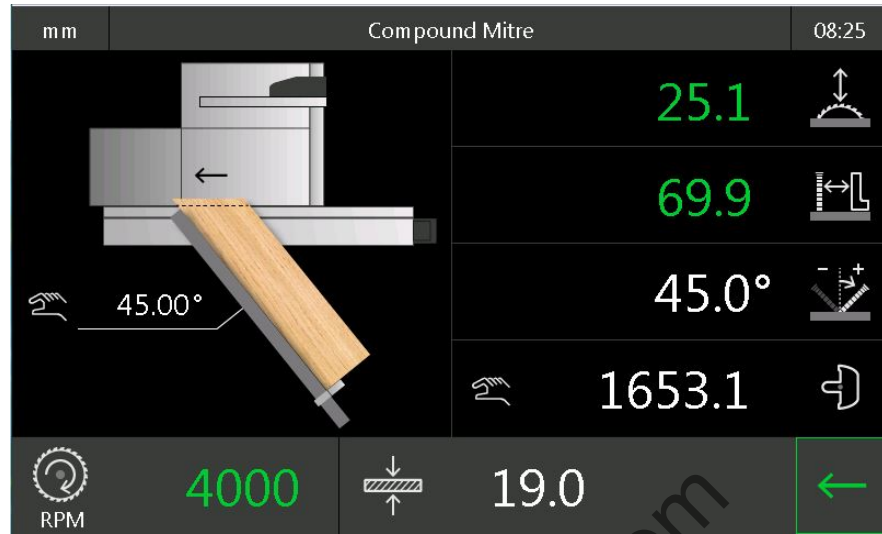

Fig. 6-70 Shifter cut, 2nd page

Press the arrow button to return to the first page.

www.DaltonsWadkin.com

## Programs

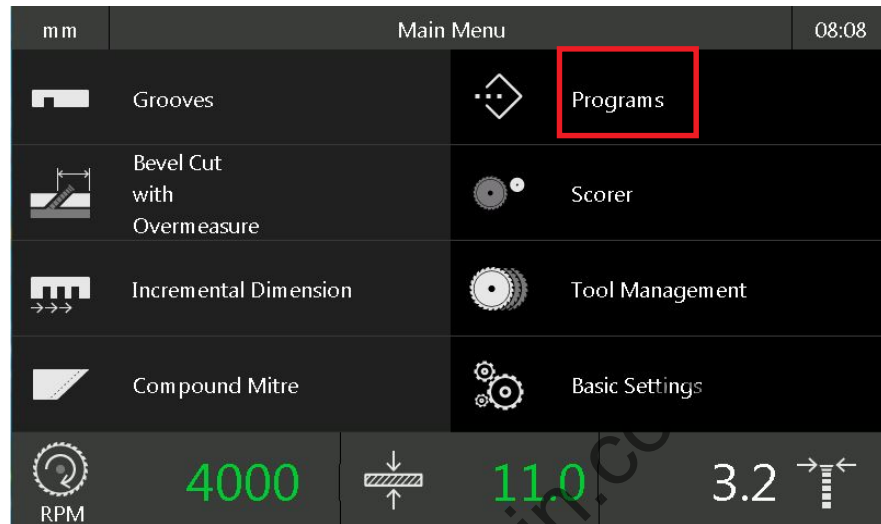

Fig. 6-71 Main menu

For the program function, touch the highlighted button, the following screen appears:

www.DaltonsWadkin.com

Fig. 6-72 Programs

Press the + button to create a new program.

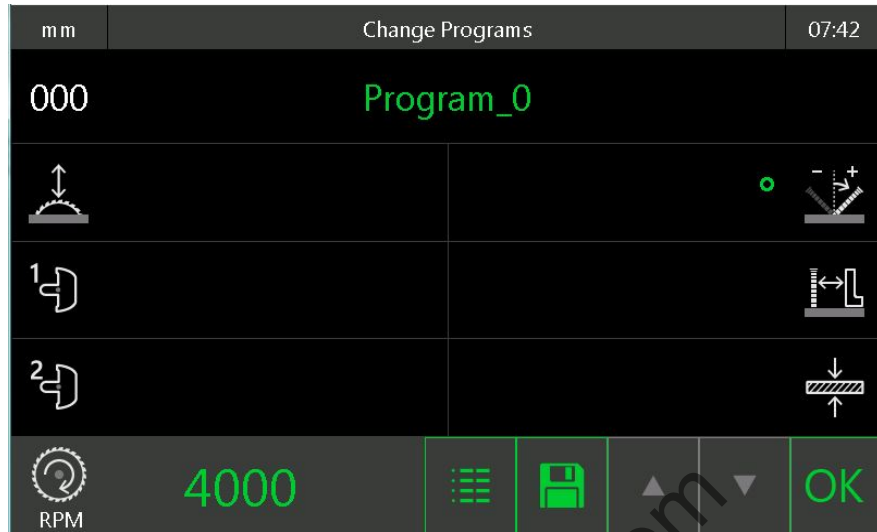
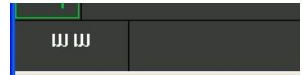

Fig. 6-73 Enter program

*Entering positions:*

Touch the respective field, enter a value, confirm with Enter

*Deleting a position:*

Touch the respective field, CE button, confirm with Enter

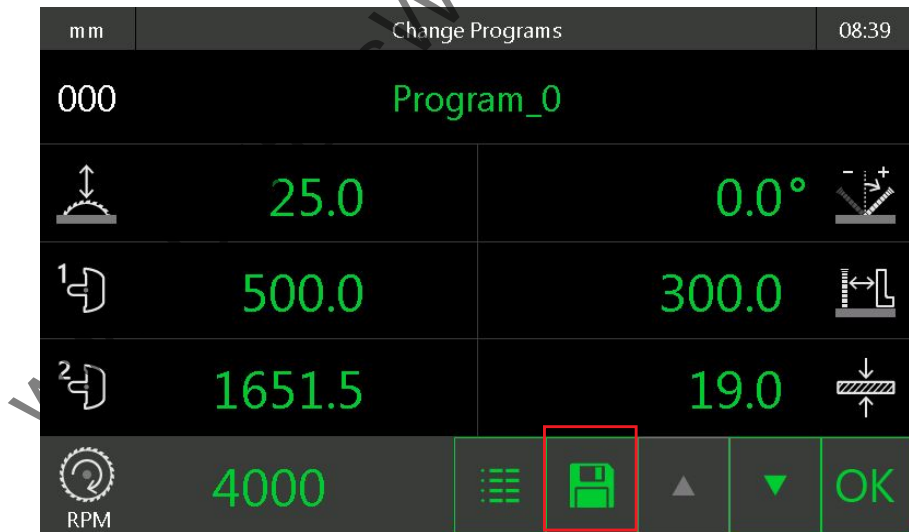

Fig. 6-74 Enter program

Touch the highlighted button to save the program

mm	Programs						08:40
→	Name						
000	Program_0	25.0	0.0	500.0	1651.5	300.0	19.0
001	Program_1	75.0	0.0				11.0
002	Program_2	50.0				20.0	
003	Program_3						
004	Program_4		0.0				

RPM 4000 +     OK

Fig. 6-75 Program saved

www.DaltonsWadkin.com

## 2-axis scorer

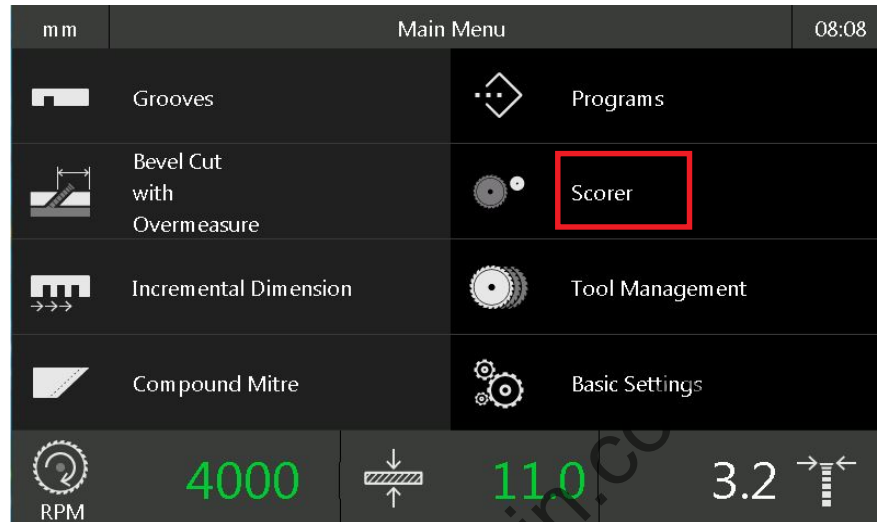

Fig. 6-76 Main menu

For scorer adjustment, touch the highlighted button, the following screen appears:

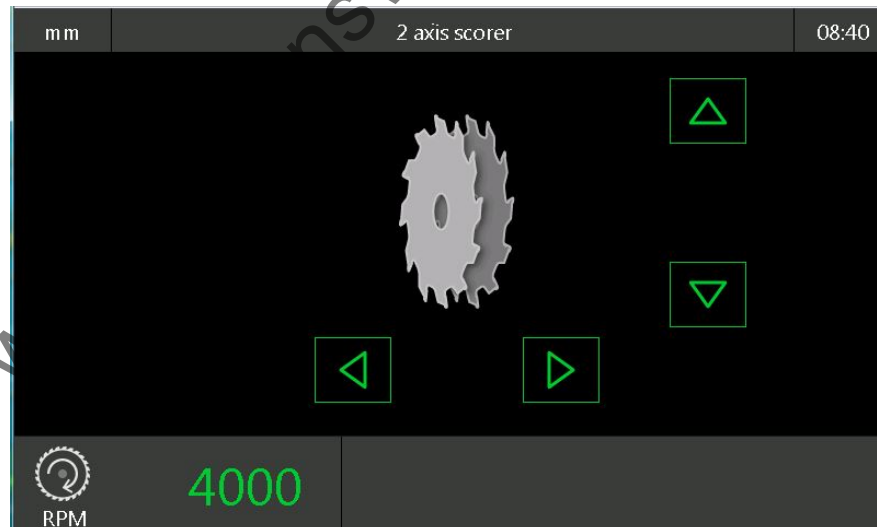
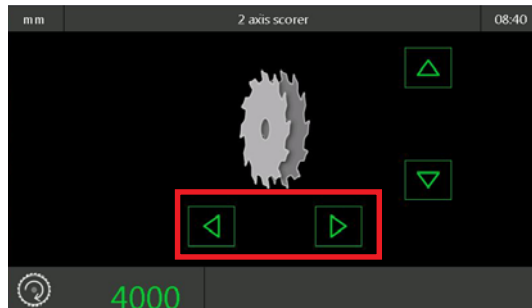
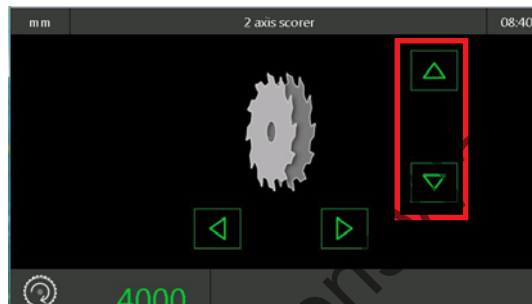

Fig. 6-77 Adjusting the scorer

- [1] The cutting height of the scorer and the side position can now be changed by means of the arrow buttons.
- [2] Once this function is exited, the scorer moves down if the motor is off. Otherwise it moves down when the scorer motor is switched off, on returning from an EMERGENCY STOP, and when the machine is switched on. The height position that has been set is saved.

**Side adjustment:**

- Briefly touching the horizontal arrow buttons causes minimal adjustments of approx. 0.03 mm.
- Holding these buttons down causes bigger adjustments.

**Height adjustment:**

- Briefly touching the vertical arrow buttons causes minimal adjustments of approx. 0.1 mm.
- Holding these buttons down causes bigger adjustments.

When the scorer motor is on, the scorer is in the top position. Otherwise it is moved up when the function is invoked.

### 3-axis scorer

**RAPIDO Plus** is a 3-axis scoring system with motorised adjustment of the cutting height and the right and left-hand side of the scoring saw blade. All settings can be made while the machine is running, so they can be done very quickly.

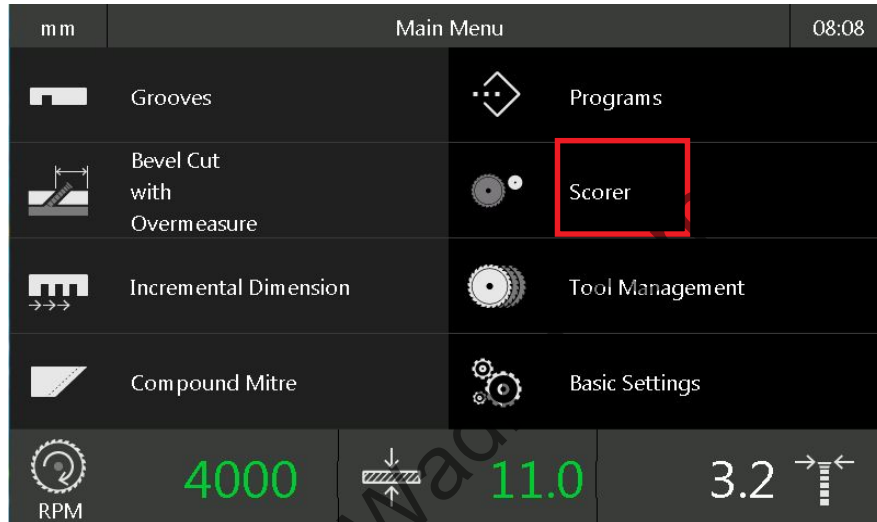

Fig. 6-78 Main menu

For scorer adjustment, touch the highlighted button, the following screen appears:

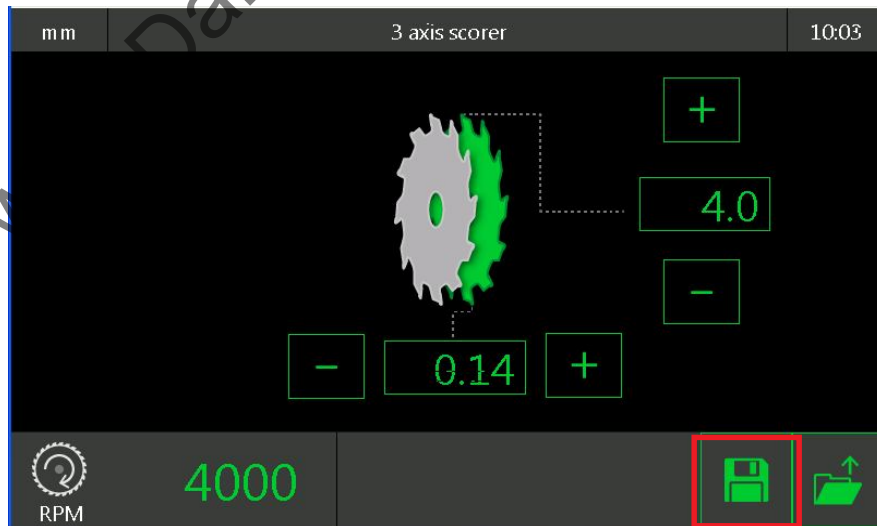

Fig. 6-79 Adjustment\_scorer saw blade RH



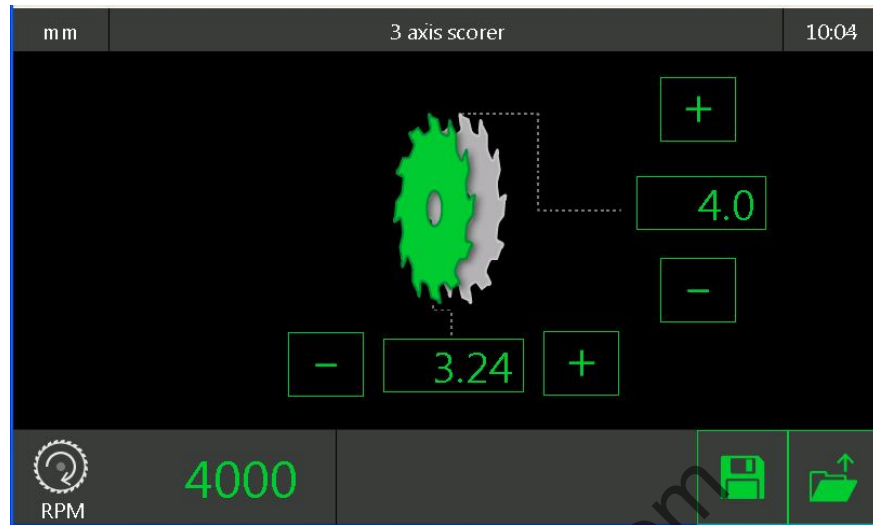

Fig. 6-80 Adjustment\_scorer saw blade LH

Select the saw blade side by touching the saw blade in the screen graphics. Use the + or - button to change the height and side position. In addition, you can touch a dimension and enter a new value by means of the numerical keypad, which will be positioned once the Start button is pressed.

**Note!**

The positions given for the saw blade sides are guide figures only.

Touch the highlighted button to save the setting of the scorer and assign it to a tool, see next screen.

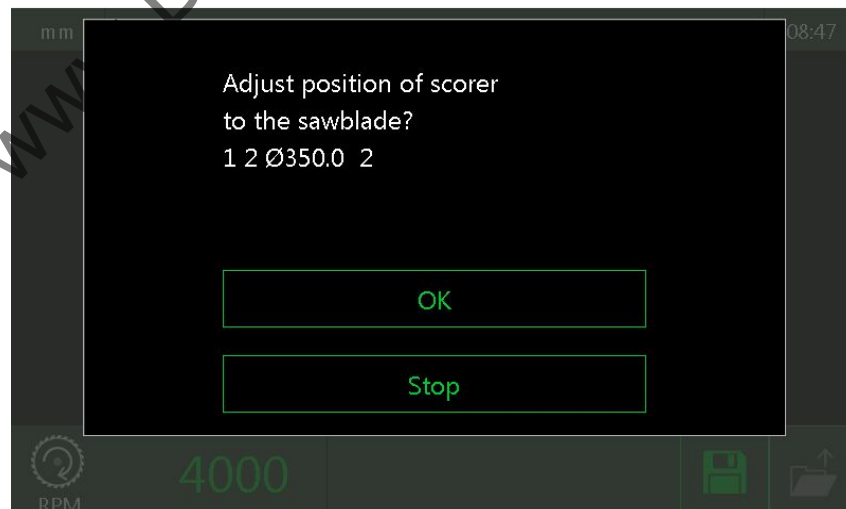

## 6 Operating

### Tool management

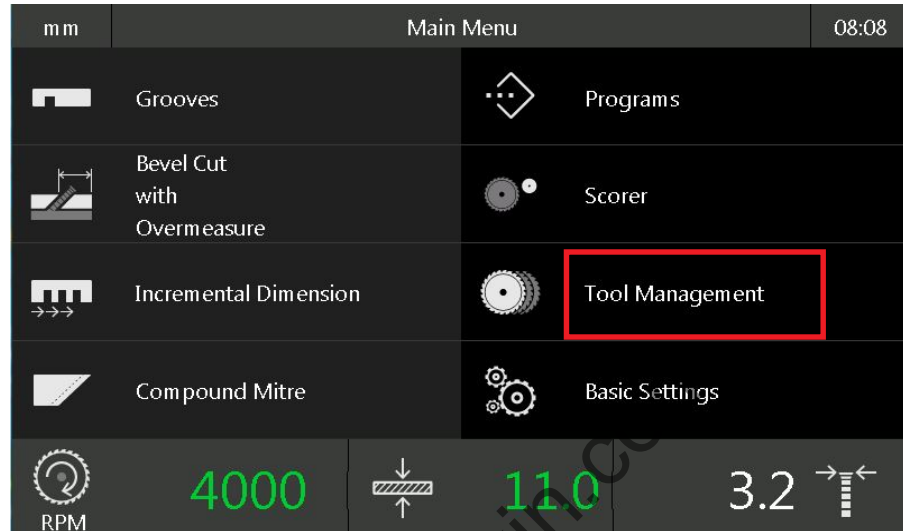

To call up the tool management, touch the highlighted button, the following screen appears:

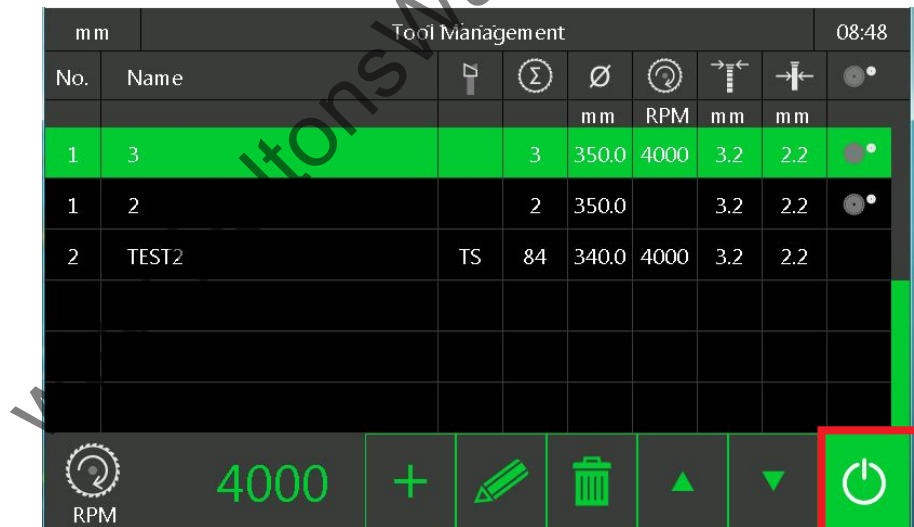

Fig. 6-81 Tool management activated

Touch the highlighted button to activate or deactivate the tool management function

m m		Tool Management						08:49
No.	Name		$\Sigma$	$\emptyset$				
				mm	RPM	mm	mm	
1	3		3	350.0	4000	3.2	2.2	
1	2		2	350.0		3.2	2.2	
2	TEST2	TS	84	340.0	4000	3.2	2.2	

RPM

4000

+

Fig. 6-82 Tool management switched off

After pressing the red button, the data of the selected tools can be changed, the following screen appears:

m m		Change tool Number1		08:49
Name	3			
$\emptyset$ Diameter	350.0	3.2	Kerf	
$\Sigma$ No. of Teeth	3	2.2	Plate width	
Tooth form		4000	rotational speed	

RPM

4000

Fig. 6-83 Creating/changing a tool

Touch the respective field to change the value or delete it by means of CE. Press the Enter button to apply values.

6 Operating

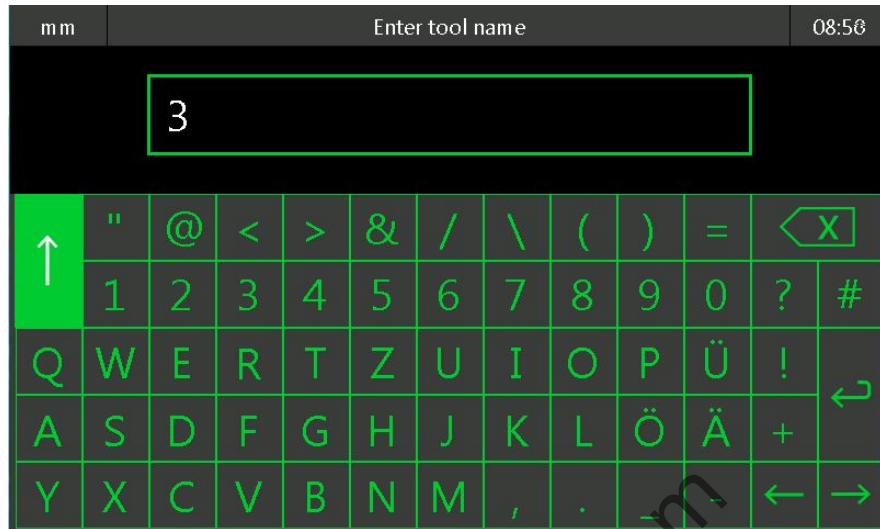

Fig. 6-84 Name a tool

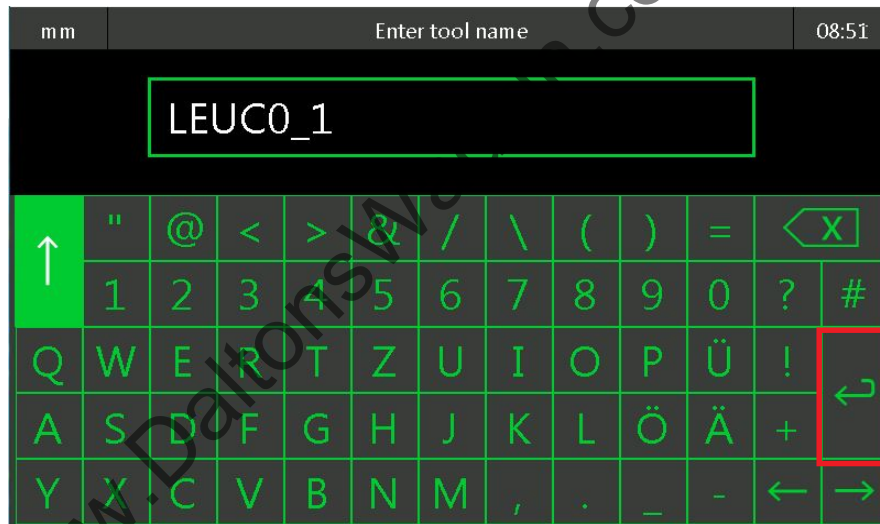

Fig. 6-85 Name a tool

Complete the input by pressing the ENTER button (displayed in red)

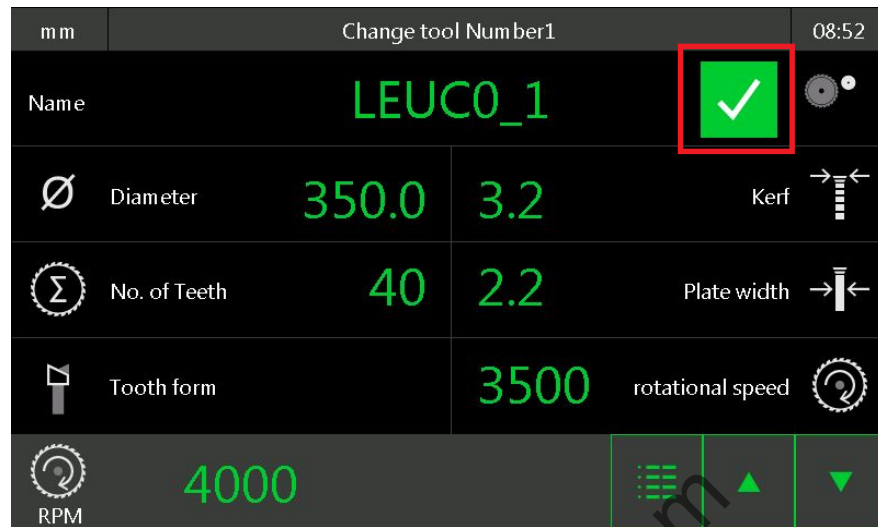

Fig. 6-86 Assigning a scorer

The current position of the 3-axis scorer is saved with the tool, once the highlighted button is touched and turns green.

You can also delete the stored scorer position by tapping the checkmark to remove it.

Use the Back, Home or Menu button to exit tool management and select the highlighted tool.

If tool management is active, the data of the highlighted saw blade is now applied. In addition, the 3-axis scorer moves to the scorer position saved with the saw blade.

With the VARIO option, the rotational speed assigned to the tool is applied.

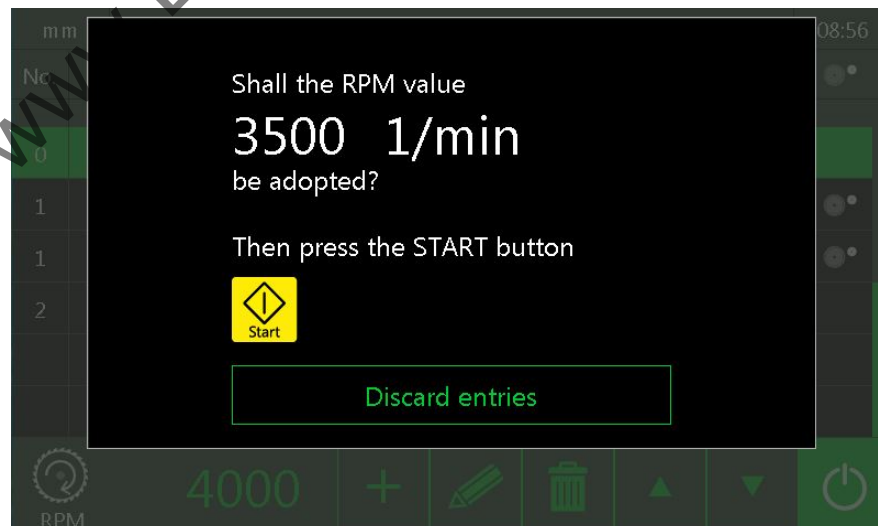

Fig. 6-87 Rotational speed transfer

## 6 Operating

### Basic settings

#### Design / unit

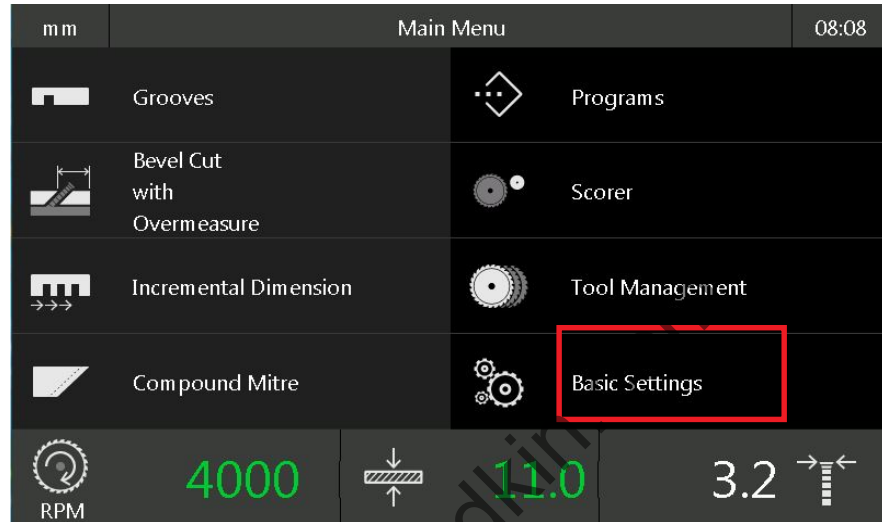

Fig. 6-88 Main menu

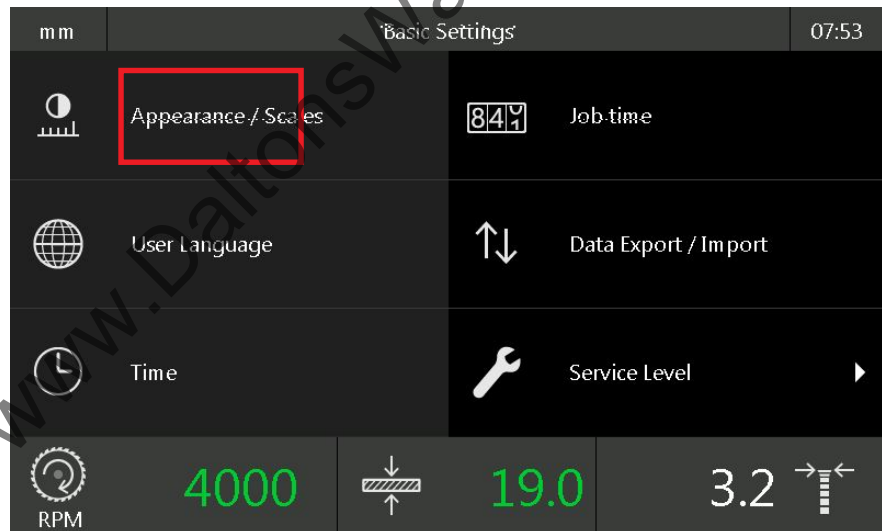

Fig. 6-89 Basic settings

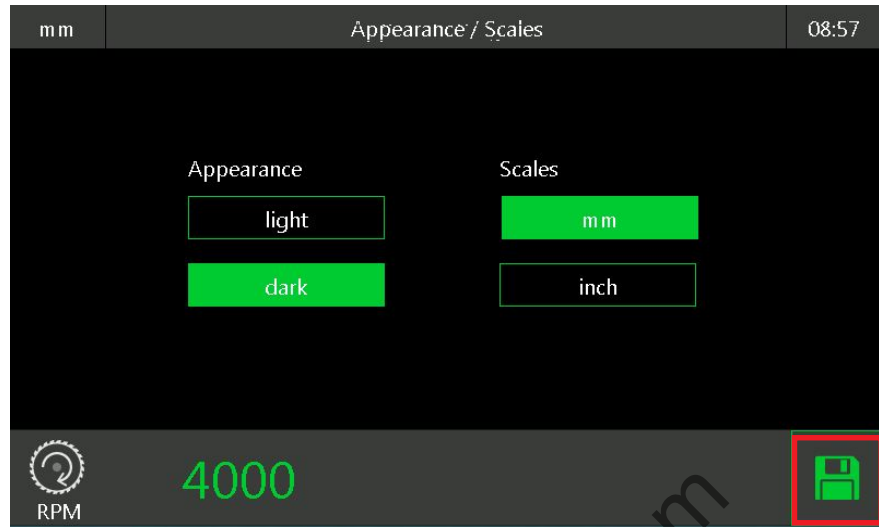

Fig. 6-90 Design / unit

Select the desired setting and save with the highlighted button.

www.DaltonsWadkin.com

## 6 Operating

### Language

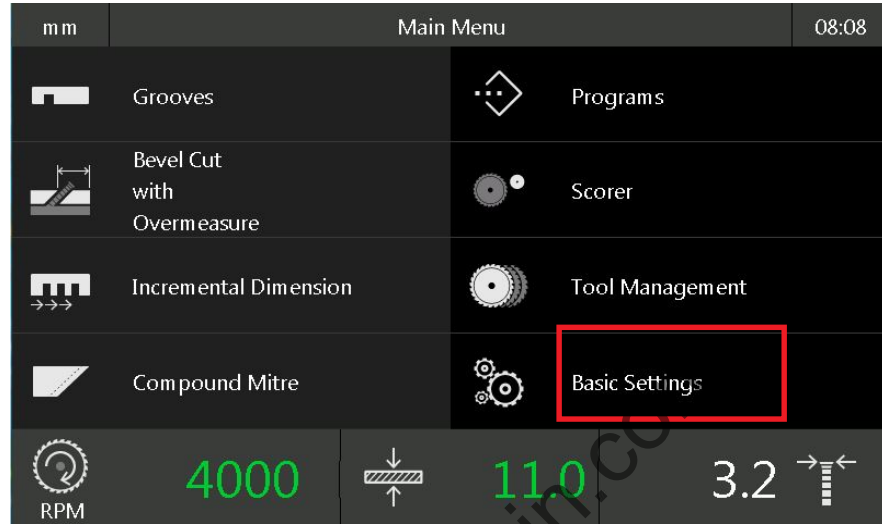

Fig. 6-91 Main menu

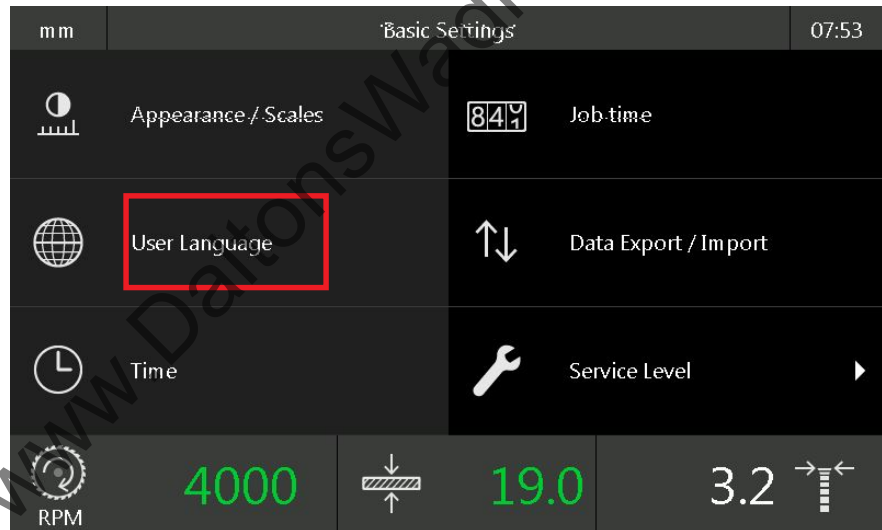

Fig. 6-92 Basic settings



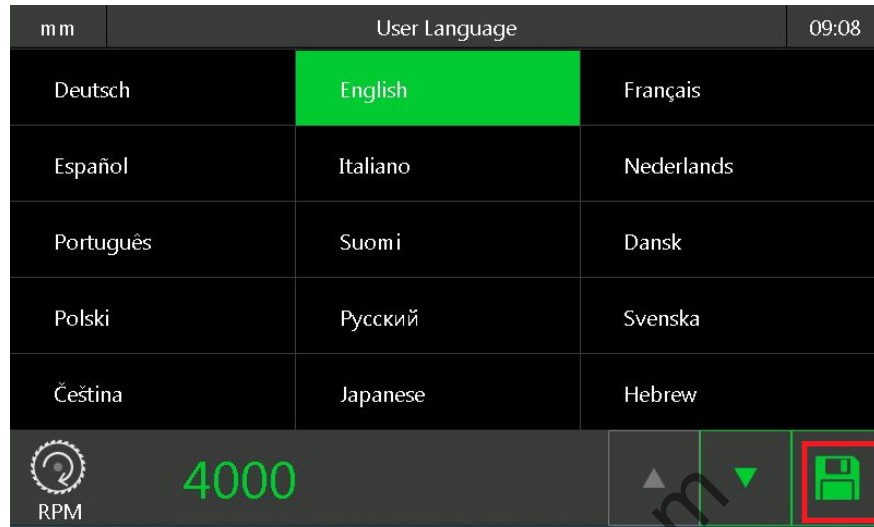

Fig. 6-93 Selecting a language

Select a language and save with the highlighted button.

www.DaltonsWadkin.com

## 6 Operating

### Time

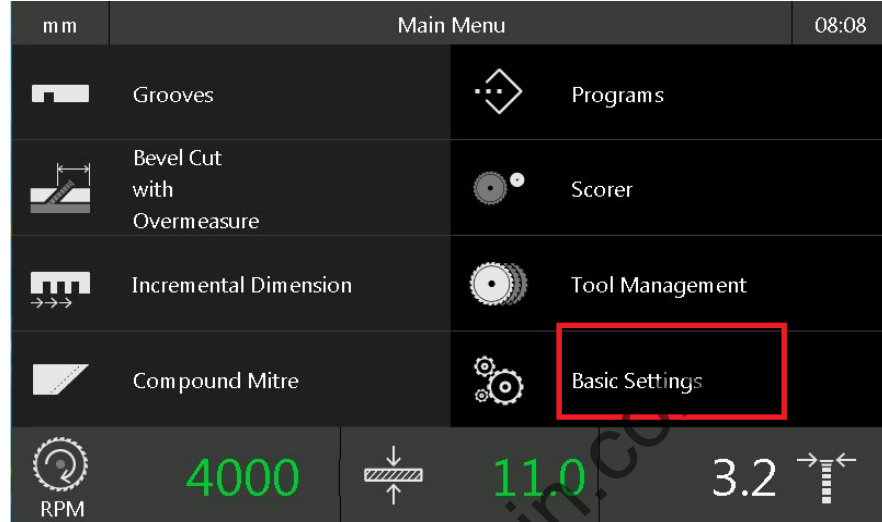

Fig. 6-94 Main menu

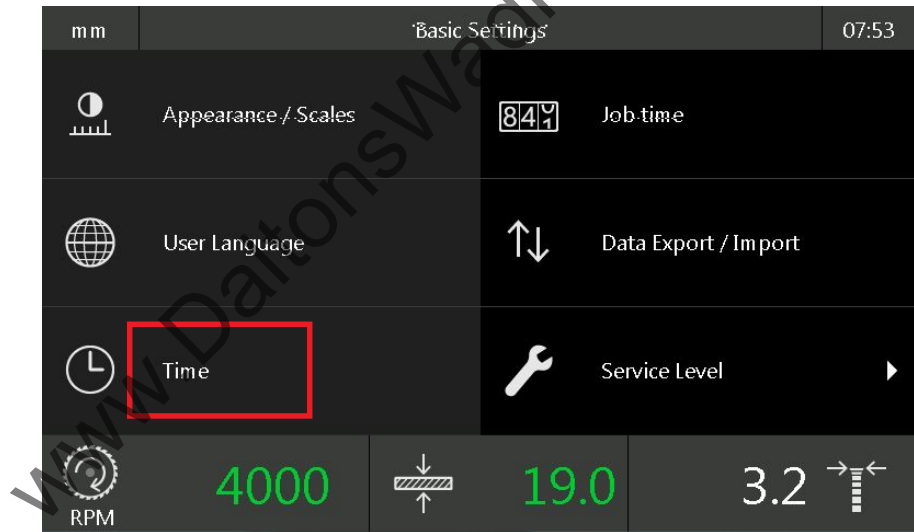

Fig. 6-95 Basic settings

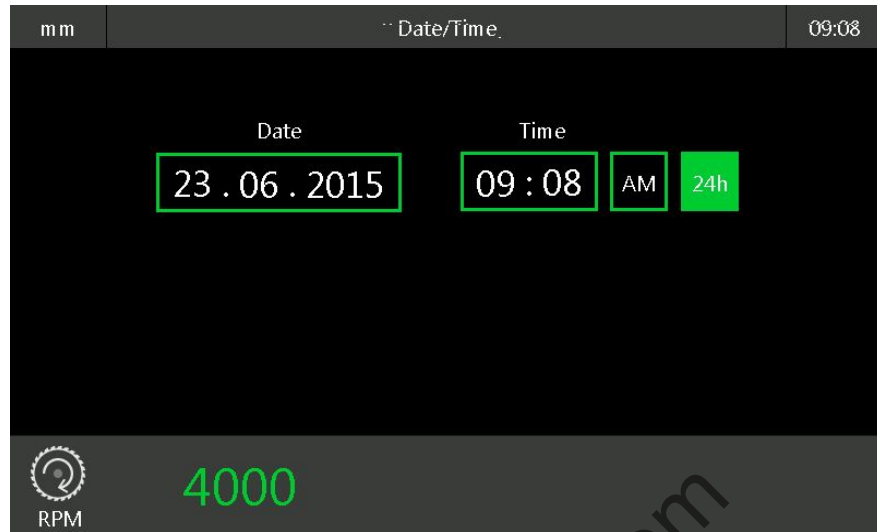

Fig. 6-96 Setting a date/time

You can choose between a 12 and 24 hour display.

www.DaltonsWadkin.com

## 6 Operating

### Running time

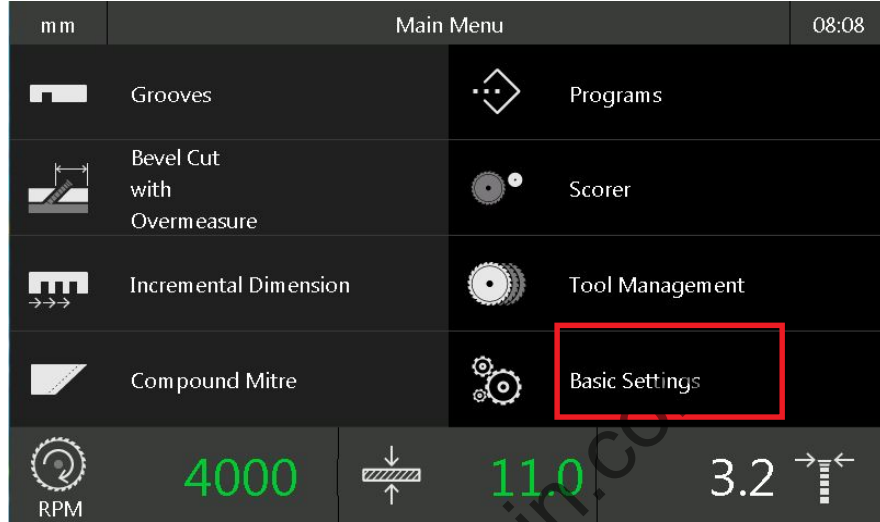

Fig. 6-97 Main menu

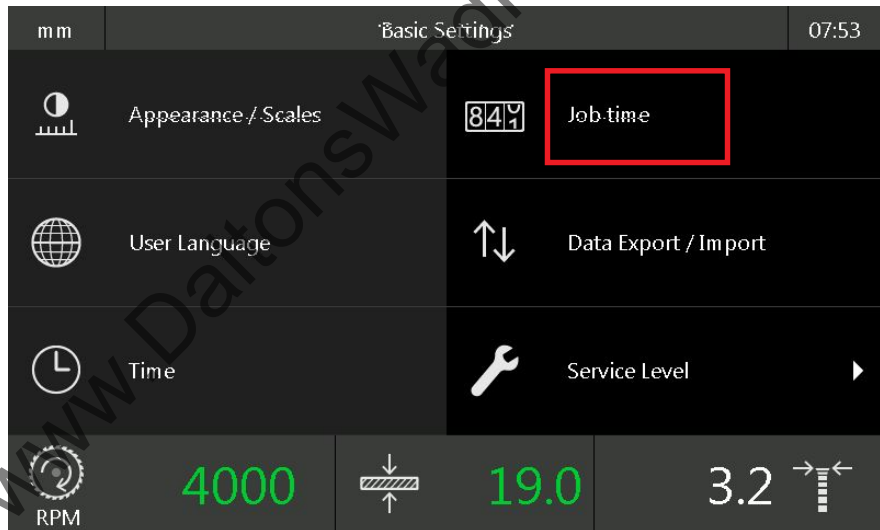

Fig. 6-98 Basic settings







mm	Distance ran		09:09
	0.003 km	3 °	
	0.000 km	0.007 km	
	0.000 km	0 h	
 RPM	4000		

Fig. 6-99 Operational performance of the axes

www.DaltonsWadkin.com

## 6 Operating

### Data export/import

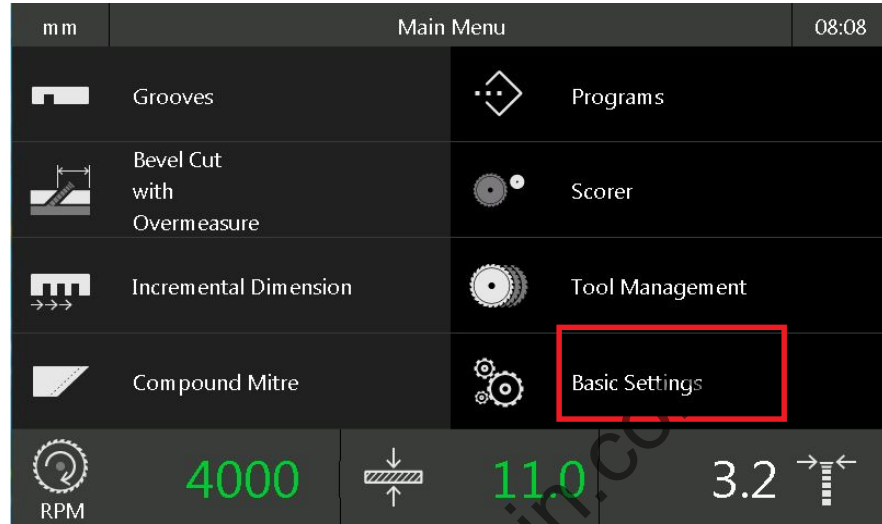

Fig. 6-100 Main menu

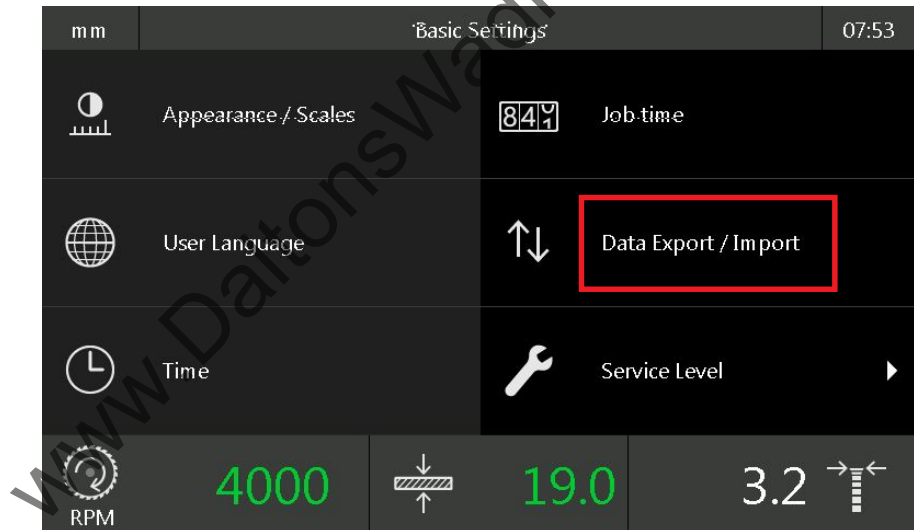

Fig. 6-101 Basic settings

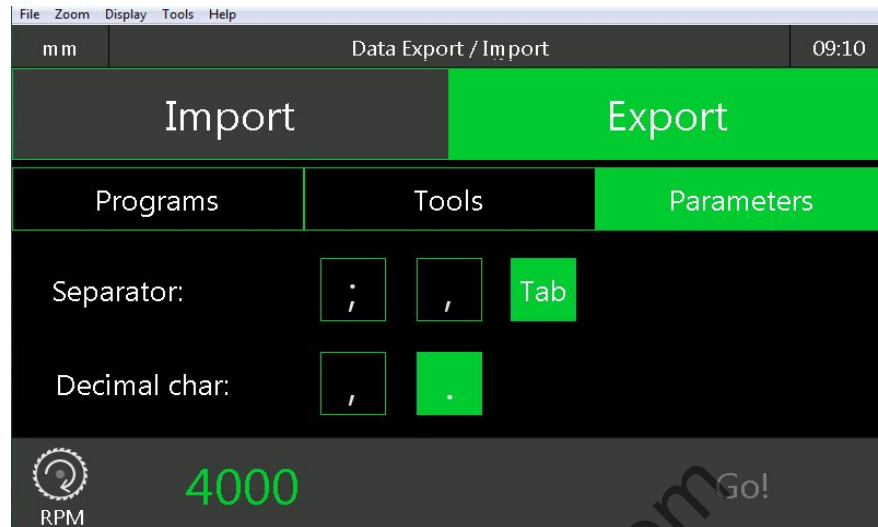

Fig. 6-102 Data import/export

Touch the respective fields to copy programs, tools or machine parameters to a USB flash drive (export) or from a USB flash drive into the machine (import).

The following file names are used for this:

- Programs: prog.txt
- Tools: tool.txt
- Parameters: par.txt

Export programs and tools using tabs as separators and commas as decimal marker. They can then be changed and added to on a PC by means of a spreadsheet program. When saving, ensure that the file is saved in the proper format.

## 6 Operating

### Technician level

#### Technician level

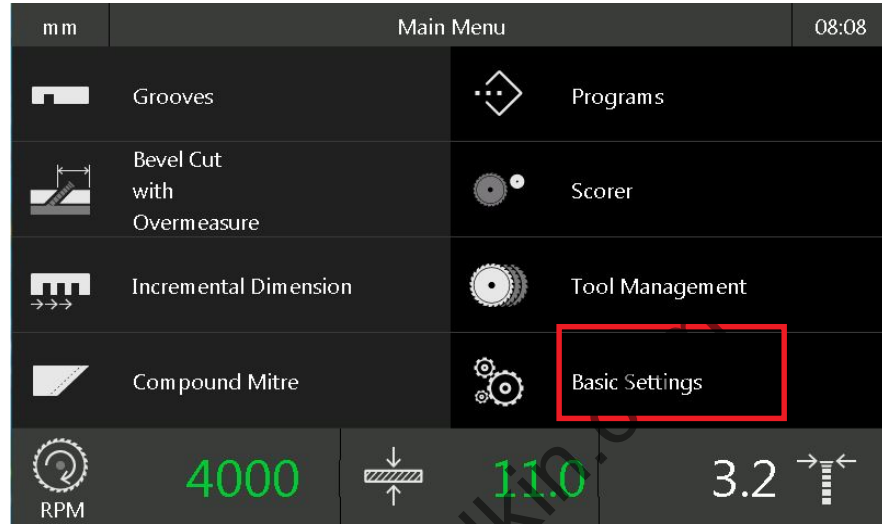

Fig. 6-103 Main menu

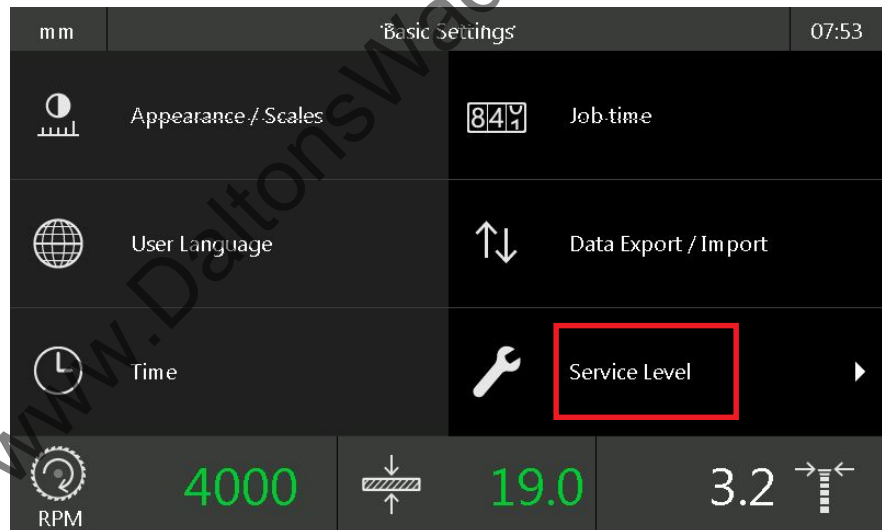

Fig. 6-104 Basic settings



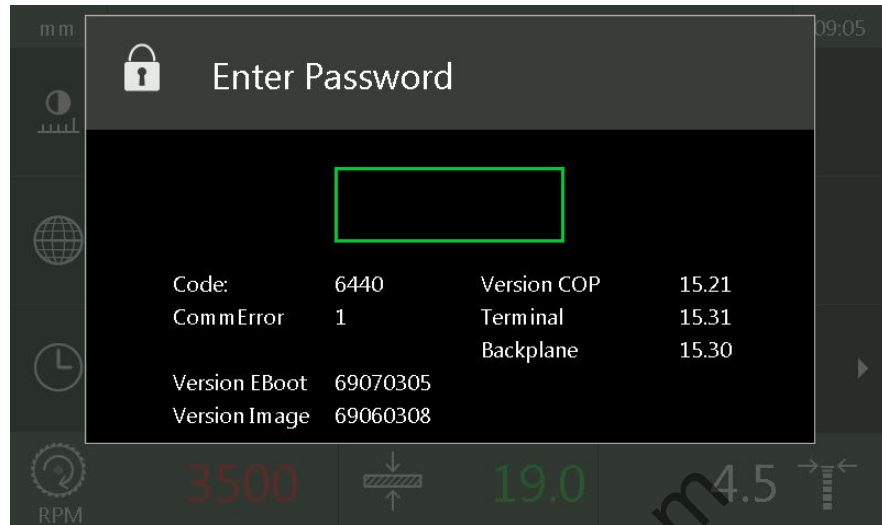

Fig. 6-105 Technician level

To install a software update, enter the password **77997**.

www.DaltonsWadkin.com

## 6 Operating

### 6.5 Protection hood



Fig. 6-106 Protection hood swung away

Swing away the protection hood as follows:

- Turn off the main switch and secure against turning on again
- Actuate the release lever
- Swing the protection hood away



#### Warning!

You may only work with the protection hood swung away in special cases and with increased caution, e.g. for bulky workpieces.



Fig. 6-107 Normal working position

[1] Unlocking/locking lever



**Note!**

After completing the work cycle, immediately swing the protection hood back into the normal working position and lock it with the lever.

Pull the lever forward until it noticeably engages.

### Changing the protection hood sections



Fig. 6-108 Swivel out the hood section

When changing between wide and narrow, it is not necessary to completely exchange the hood but only the respective hood section by means of a snap fit.

For exchanging the hood section, press the red pusher down and swivel out the hood section. Suspend the other hood section and swivel in until the snap fit engages.



Fig. 6-109 Large protection hood with wide hood section

### Protection hood, machine tilting to both sides

Installing the wide protection hood, see photo and text on previous page.

For tilting in the negative range (-), the protection hood is pulled out after unlocking the lever at the rail guide.



Fig. 6-110 Lateral displacement, protection hood

## 6 Operating

### 6.6 Optional modules

#### 6.6.1 Scorer, tilting to one side

When processing boards coated on both faces, the scoring unit makes it possible to cut without breakouts on the underside of the board. The scorer cuts into the material from below approx. 1-2 mm; then the main saw blade cuts through it. Make sure that the scoring blade is exactly in line with the main blade and is set to the corresponding width. To achieve optimum cutting results, the scoring blade runs in the workpiece advance direction, i.e. the opposite direction to the main saw blade.

The scoring saw can only be started once the main saw has reached its operating speed (after approx. 5 sec.). It is started by pressing push-button I labelled with the scoring saw symbol on the panels.

#### Saw blades

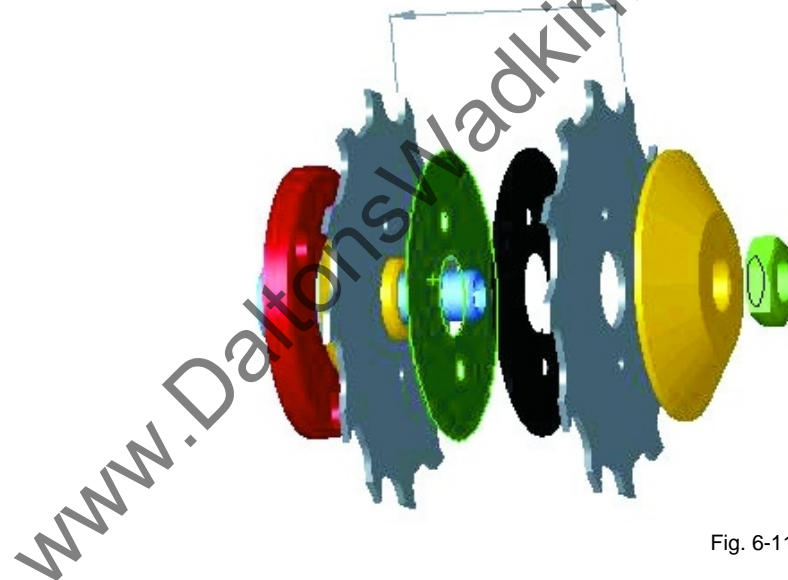

Fig. 6-111 Two-part scoring blade

We recommend using two-part scoring blades which can be set to the required blade thickness by inserting spacer discs. The cutting line of the scoring blade should be approx. 1/10 mm wider than the main saw blade, i.e., 5/100 mm to each side. In addition, the two scoring blades should have carrier pins and their thickness should be marked on the spacer discs.

The **RAPIDO scoring tool** facilitates and accelerates cutting width adjustment. Compared with two-part scoring blades, this represents a potential saving of up to 30 minutes since the cutting width can (without removing the saw blades) be adjusted infinitely to the cutting width of the main saw blade.

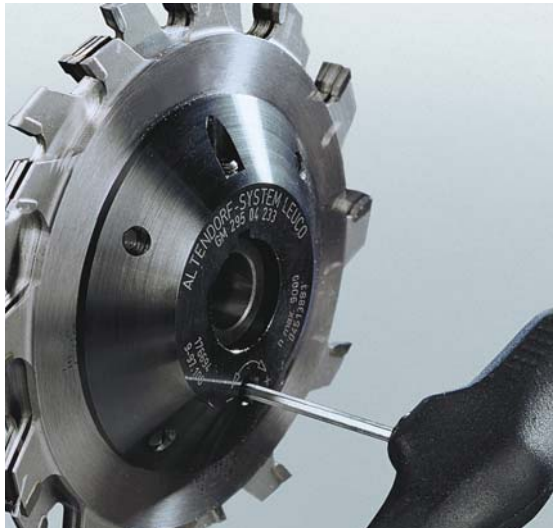

Fig. 6-112 RAPIDO scoring tool

### Fitting the saw blade

The description for fitting the saw blade applies both to two-part scoring blades and to **RAPIDO** scoring tools.

Only use saw blades with a diameter of 120 mm and a hole diameter of 22 mm!

- Switch off the drives.
- Move the scoring saw up to its highest position.
- Move the sliding table in the cutting direction.
- Unlock the lock in the middle of the saw blade by pressing the knob on the middle carriage.
- Move the sliding table to the end position in the cutting direction.
- Open the bottom hinged safety cover (orange coloured cover plate).
- Release the nuts with a special wrench by turning counterclockwise.
- Before fitting the new scoring blade, remove any adhering chips from both flanges.
- Place the saw blade and front flange on the saw shaft, and tighten the nut clockwise.



---

**Attention!**

The following must also be observed when using RAPIDO scoring blades with infinitely variable cutting width adjustment:

- Failure to comply with the operating instructions inadmissibly reduces Health and Safety at Work and excludes any claims for liability.
  - Incorrect use and use other than that intended is forbidden.
  - Permissible cutting widths 2.8 - 3.8 mm
  - Take particular caution when unpacking and packing the adjustment unit, danger of injury!
  - Only store the adjustment unit in the original packaging!
  - Fit the scoring blade outside of the machine.
  - Make sure that all connection elements are fitted.
  - Only use original spare parts in the case of loss or damage to the connection elements!
- 

**Adjusting a two-part scoring blade**

The cutting width of the scorer should be set to the cutting width of the main saw blade (+ 0.05 mm). Carry out the adjustment toward the left side of the main saw blade. The cutting width is adjusted with the spacing discs that are supplied.



### Adjusting the scoring blade for the RAPIDO scoring tool

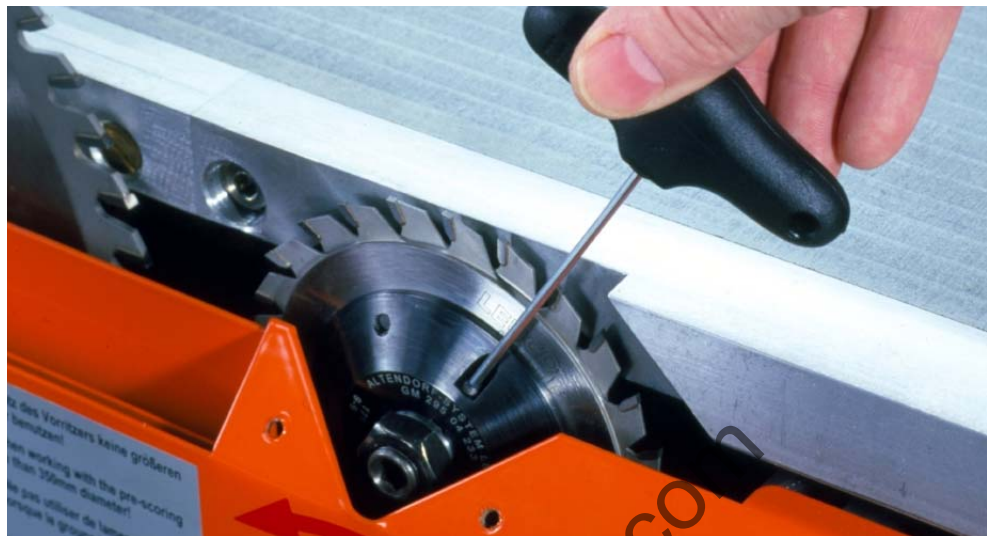

Fig. 6-113 Release the clamping screw.



Fig. 6-114 Adjust the spindle.

#### Note!



Only use the supplied tools for adjustment work!

- Release the clamping screw, approx. 2 turns.
- Turn the spindle until the required dimension is reached. (1 turn = 0.5 mm)
- Tighten the clamping screw.
- Make a test cut and, if necessary, correct the cutting width again as described above.

### Replacing the scoring blade for RAPIDO

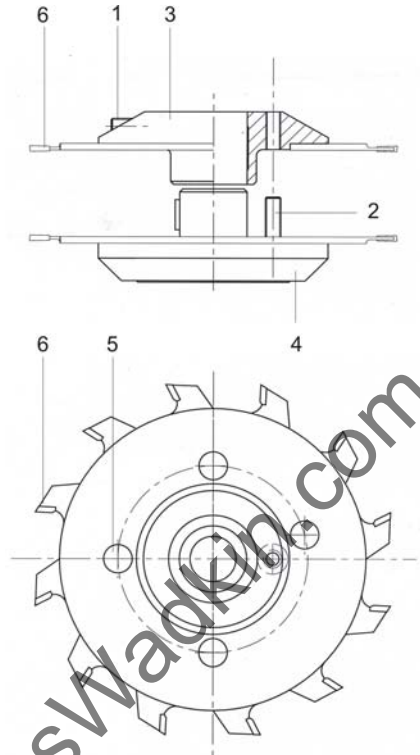

Fig. 6-115 RAPIDO saw blades

Remove the adjustment unit from the machine. It may be necessary to loosen the clamping screw because an excessively tight clamping screw can cause the adjustment unit to jam on the shaft!

#### Dismantling

Using the Allen wrench:

- Release the clamping screw (1), turn the spindle (2) approx. 3 – 4 turns clockwise until the flange (3) can be removed from the holder (4).

Using the internal torx wrench:

- Undo the screws (5).
- Remove the circular saw blade (6).
- Carefully clean the flange (3) and screws (5). Make sure that the running and flange surfaces are dry and free of dust.

- Fit a new saw blade, paying attention to the rotational direction and hole pattern: The circular saw blade (6) is in full contact with the flange (3) and the shoulder on the circular saw blade must point to the contact surface.
- Turn in the screws (5) and tighten with a torque of 8.6 Nm.
- Proceed in the same manner for the other half of the adjustment unit.

**Prohibitory!**

Do not apply oil or grease!

**Installation**

- The clamping screw (1) is released.
- Fit the flange (3) vertically onto the holder (4) so that the spindle (2) engages in the threaded hole (7).
- Turn the spindle (2) counterclockwise with the Allen wrench. The flange (3) is drawn onto the holder (4); the force applied must not increase.
- Continue turning the spindle (2), until the two circular saw blade halves are in contact.
- Install the adjustment unit on the machine.
- Set the cutting width, see above.
- Slightly tighten the clamping screw (1).

## 6 Operating



### Note!

A red anodised table strip is integrated in the area of the scorer (optionally available with LED lighting).

This strip marks the hazard zone of the scoring tool.



Fig. 6-116 Red table strip (standard)



Fig. 6-117 Red table strip with lighting (optional)

**RAPIDO - PLUS**

The 3-axis scoring system allows motorised positioning of the cutting height, width and cutting width. All settings can be entered via the keypad while the machine is running, and are shown on the display.

**Replacing saw blades**

Fig. 6-118 RAPIDO Plus

- [1] Remove the adjustment unit from the machine.
- [2] Undo the screws and remove.
- [3] You can now pull the adjustment unit apart



Fig. 6-119 Disassembled RAPIDO Plus

## 6 Operating



Fig. 6-120 RAPIDO-Plus, fitting the saw blade

- [1] Undo the screws
- [2] Remove circular saw blade
- [3] Carefully clean the flange and screws
- [4] Fit a new saw blade, paying attention to the rotational direction and hole pattern!
- [5] Insert screws and tighten with a torque of 8.6 Nm
- [6] Proceed in the same manner for the other half of the adjustment unit



### 6.6.2 Scorer, tilting to both sides

The following scorer systems are available for machines tilting to both sides:

Scorer diameter: 180 mm!

#### **Duet set**

Main saw blade and scorer blade ground to the same width in pairs

#### **RAPIDO-BS**

Width-adjustable scoring system with two saw blades, the spacing of which is adjustable

#### **3-axis scorer**

In this case, the width and side adjustment is carried out electrically in the control system.

www.DaltonsWadkin.com

## 6 Operating

### 6.6.3 Mitre fences

#### Single-sided mitre fence



Fig. 6-121 Single-sided mitre fence

The fence can be fitted quickly and easily to the sliding table with an eccentric clamping system. Dimension scales are inclined in order to stay in the operator's field of vision. Crosscutting to 2500 mm.

#### Double-sided mitre fence DUPLEX



Fig. 6-122 Double-sided mitre fence DUPLEX



The DUPLEX mitre fence can be infinitely adjusted from 0° to 90°. The circular scale with a radius of 350 mm has 0.25° graduation, allowing precise and fast setting of the mitre angle. The DUPLEX mitre fence can be fitted at any position of the sliding table due to its eccentric clamping system.

The stop bar (2 throw-over stops) can be used in both stop profiles. It is possible to crosscut workpieces of up to 1350 mm in length or, when the extended stop fence is used, up to 2150 mm in length.

In addition, the DUPLEX and DUPLEX D mitre fence features a length compensation scale with which the length dimension is set in accordance with the mitre angle.

**Note!**

*Separate instructions are enclosed for the selected options DUPLEX, DUPLEX D or DUPLEX DD.*

## 6 Operating

### 6.6.4 DIGIT L dimension display unit



Fig. 6-123 DIGIT L

The dimensions that have been set are displayed digitally in the 150 mm to 3200 mm range to an accuracy of  $\pm 0.1$  mm. The proximity sensor operates wear-free and is not sensitive to dust. A precise adjustment system is used for precision setting in 1/10 mm increments.

#### Operating the display electronics



Fig. 6-124 DIGIT L display unit

Press button 1: switches over the throw-over stop side. Pressing button 2, 3 or 4 changes the measuring range on the display electronics. Throw-over stop 1 is permanently connected to the measuring system and the display unit. The measuring range is from approx. 150 mm to approx. 1630 mm. Throw-over stop 2 is a flip stop and, when it makes contact at the left of throw-over stop 1, it is at a distance of 295.0 mm from throw-over stop 1. This results in a measuring range of approx. 445 mm to approx. 1750 mm. If throw-over stop 2 is pushed onto the length extension, this results in a measuring range of about 1750 mm to 3200 mm; if necessary, the length extension can be connected to throw-over stop 1 with the aid of the detent bolt.

### Power supply

Power is supplied by a rechargeable battery. The charging state is shown in the bottom right hand corner of the display. The batteries can be recharged using the supplied charger.

### Changing the rechargeable battery



Fig. 6-125 Changing the rechargeable battery for DIGIT L , DIGIT LD



Fig. 6-126 Battery charger

#### Note!



For information on how to handle batteries, see chapter 3.6.4

### Basic setting / calibration of the display unit

The basic setting of the display unit is needed in order to adapt the measuring system to the machine situation. Check and, if necessary, re-enter the basic settings following each tool change.

How to proceed:

- Push throw-over stop 1 with the display unit to the right against the mechanical stop.
- Fix throw-over stop 1 with a clamping screw.
- Cut a test piece, measure the workpiece width with a calliper and enter the precise value as follows:
- Press key 2; after three seconds the following calibration menu will appear (only the first throw-over stop can be calibrated).



Fig. 6-127 Calibration

- [1] Press the adjacent function key to select the required decade. If the highest decade has been selected and the function key is reactivated, the lowest decade is automatically selected.
- [2] Press the "+" key to increment the display value of the active decade.
- [3] Press the "-" key to decrement the display value of the active decade.
- [4] Press the adjacent function key to store the new throw-over stop value under parameter L-L1; this value is also automatically calculated with the throw-over stop values displayed on the user interface.

### Switching the display unit from mm to inches or inches to mm

- Press the Menu button
- Select inch (or mm) as the measuring unit.

### 6.6.5 Digital angle and length display DIGIT LD



Fig. 6-128 Crosscut-mitre fence display unit WGA\_LD

The angle is shown in the display to an accuracy of  $0.01^\circ$  and the dimensions set in the 150 mm to 3200 mm range are shown in the display to an accuracy of  $\pm 0.1$  mm. The length dimensions shown are automatically corrected when the angle is changed.

#### Operating the display electronics



Fig. 6-129 Display unit

Pressing buttons 2, 3, 4 on the right hand side changes the measuring range on the display electronics. The dimension of the current throw-over stop is shown in bold. Throw-over stop 1 is firmly connected to the measuring system and the display unit. Throw-over stop 2 is a flip stop and, when it makes contact at the left of throw-over stop 1, it is at a distance of approx. 200.0 mm from throw-over stop 1. If throw-over stop 2 is pushed onto the length extension, this results in a measuring range of about 1750 mm to 3200 mm; if necessary, the length extension can be connected to throw-over stop 1 with the aid of the detent bolt.

Pressing button 1 (RH side) for more than 3 seconds switches over the degree display.

The fence position is switched over on the cross-slide by pressing the button on the left hand side.

## 6 Operating

### Power supply

Power is supplied by a rechargeable battery. The charging state is shown in the bottom right hand corner of the display. The batteries can be recharged using the supplied charger.

### Changing the rechargeable battery



Fig. 6-130 Changing the rechargeable battery for DIGIT L , DIGIT LD



Fig. 6-131 Changing the rechargeable battery for WGA DIGIT LD



Fig. 6-132 Battery charger

### Note!



For information on how to handle batteries, see chapter 3.6.4

### Basic setting / calibration of the display unit

The basic setting of the display unit is needed in order to adapt the measuring system to the machine situation. Check and, if necessary, re-enter the basic settings following each tool change.

How to proceed:

- Push throw-over stop 1 with the display unit to the right against the mechanical stop.
- Fix throw-over stop 1 with a clamping screw.
- Cut a test piece, measure the workpiece width with a calliper and enter the precise value as follows:
- Press key 2; after three seconds the following calibration menu will appear (only the first throw-over stop can be calibrated).



Fig. 6-133 Calibration

- [1] Press the adjacent function key to select the required decade. If the highest decade has been selected and the function key is reactivated, the lowest decade is automatically selected.
- [2] Press the "+" key to increment the display value of the active decade.
- [3] Press the "-" key to decrement the display value of the active decade.
- [4] Press the adjacent function key to store the new throw-over stop value under parameter L-L1; this value is also automatically calculated with the throw-over stop values displayed on the user interface.

### Switching the display unit from mm to inches or inches to mm

- Press the Menu button
- Select inch (or mm) as the measuring unit.



## 6 Operating

### 6.6.6 Rip fence with DIGIT X digital dimension display



Fig. 6-134 Rip fence with Digit X

The electronic measuring system with digital display and fine setting system ensures precise and fast setting of the rip fence. The display is always in the field of vision. The touch-free measuring system is not sensitive to dust. When the guide surface of the stop fence is changed, the dimensions are corrected automatically in the measuring system.

#### Changing the batteries



Fig. 6-135 Release the clamping screws





Fig. 6-136 Remove the housing with the display unit

**Note!**



For information on how to handle batteries, see chapter 3.6.4



Fig. 6-137 Undo the screws and remove the cover.



Fig. 6-138 Change the batteries, ensuring correct polarity

### Basic setting of the display unit



Fig. 6-139 Operating the Digit X

The basic setting of the display unit is needed in order to adapt the measuring system to the machine situation. Check and, if necessary, re-enter the basic setting for each tool change. The basic setting can only be carried out together with the tools used so it cannot be done at the factory.

- Push the rip fence to the left against the mechanical stop
- Hold the F button down and press the Reset button
- Set the rip fence to a cutting width of 130 mm (straight edge in the position of the low guide surface)
- Cut a test piece and measure the workpiece width with a sliding calliper
- Hold the F button down; the right-hand digit of the display starts flashing after approx. 3 seconds
- Pressing the + button increases the flashing digit by 1 each time. When the maximum number value 9 is passed, the numbers start again with 0.
- Pressing the Minus button decreases the flashing digit by 1 in each case.
- Release the F key.
- The dimension that has been set is saved as the basic setting.

### Calibrating the display unit

Calibration of the display unit is required when the fence has been moved under the main table.

- Push the rip fence to the left against the mechanical stop
- Hold the F button down and briefly press the Reset button; the display shows the basic setting again.

### Switching the display unit from mm to inches or inches to mm

- Hold the + button down for more than 3 seconds; the display shows inches (or mm).
- Release the + key; the display unit now shows the set dimension in inches (or mm).

www.DaltonsWadkin.com

### 6.6.7 Parallel cutting device

#### Parallel cutting device



Fig. 6-140 PALIN parallel cutting device

Parallel cutting of long, narrow parts is done to the left of the saw blade. The PALIN and PALIN\_D parallel cutting devices are good for this. In parallel cutting, the flip stop is set to the same dimension at the crosscut fence and at the PALIN. The workpiece can be placed safely and be guided easily on the left of the saw blade.

#### Parallel cutting device with digital dimension display and precision setting system



Fig. 6-141 PALIN D parallel cutting device

PALIN\_D with digital dimension display and precision setting system A precise adjustment system is used for precision setting in 1/10 mm increments. Both parallel cutting devices can be adjusted to a workpiece width of up to 900 mm.



Alkali manganese batteries have an operating life of approx. 1 year. A battery capacity display provides a timely reminder of a battery change.

We do not recommend the use of rechargeable batteries of any type as their voltage and capacity differ from that of alkaline batteries. As a result, the estimated operating life of approx. 12 months would not be reached, and the symbol in the battery capacity display would not show the battery status correctly.

### Note!



For information on how to handle batteries, see chapter 3.6.4

		
<p>Carefully push out the display unit.</p>	<p>Undo the screws and remove the cover.</p>	<p>Change the batteries, ensuring correct polarity!</p>

Tbl. 6-1 Changing the batteries

### Calibrating the display unit

- Push the fence to the right against the mechanical stop.
- Fix the fence with a clamping screw.
- Hold the F button down and briefly press RESET.
- The basic setting value reappears on the display unit.

**Basic setting of the display unit**

The basic setting of the display unit is needed in order to adapt the measuring system to the machine situation. Check and, if necessary, re-enter the basic settings following each tool change. The basic setting can only be carried out together with the tools used so it cannot be done at the factory.

- Push the fence including the display unit to the right against the mechanical stop and fix with a clamping screw.
- Cut a test piece, measure the workpiece width with a vernier calliper and enter the precise value as follows:
- Press the F button, all digits of the display will light up after 3 seconds.
- Hold the F button down.
- The right-hand digit of the display starts flashing.
- Pressing the + button increases the flashing digit by 1 each time. When the maximum number value 9 is passed, the numbers start again with 0.
- Pressing the - key reduces the flashing digit by 1 each time; when the maximum numeric value (9) is passed, the numbers start again with 0.
- Release the F key.
- The dimension that has been set is saved as the basic setting.
- The display unit is now ready for operation.

**Switching the display unit from mm to inches or inches to mm**

- Hold the + button down for more than 3 seconds; the display shows inches (or mm).
- Release the + key; the display unit now shows the set dimension in inches (or mm).

## 6.6.8 Workpiece hold-down device

### Manual quick-action clamp



Fig. 6-142 Manual quick-action clamp

The manual quick-action clamp fixes the workpiece to the crosscut fence.

### Klemmfix



Fig. 6-143 Altendorf Klemmfix

Altendorf Klemmfix consists of two collets for fixing narrow and small workpieces on the sliding table. They securely hold workpieces from 0-70 mm. The collets can be used as required throughout the full length of the sliding table.



### Electro-pneumatic hold-down device

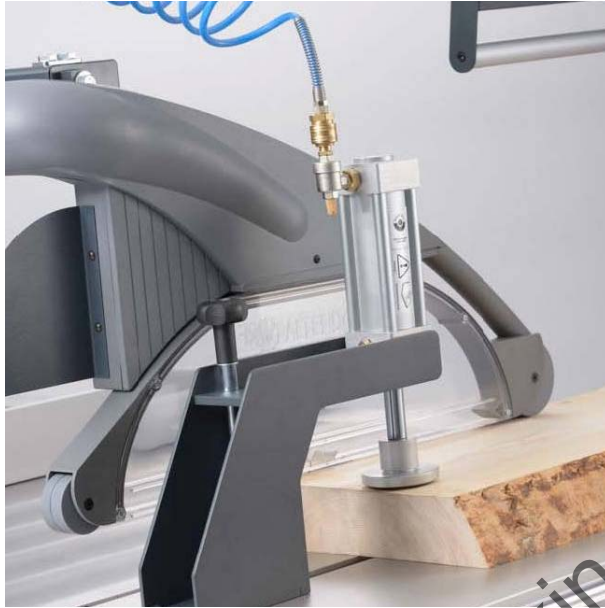

Fig. 6-144 Electro-pneumatic hold-down device

The electro-pneumatic hold-down device fixes the workpiece to the crosscut fence and operates with a clamping force of max. 100 kp at a pressure of 6 bar. The maximum clamping height is 90 mm.

The safety cylinder only clamps the workpiece when the pressure plate is positioned vertically in relation to the cylinder axis. If the pressure plate is offset by more than 2° from the vertical position, e.g. by contact with the back of the hand, no clamping force builds up.



#### Warning!

#### Danger of crushing fingers!

- Ensure that the pressure plate can freely move in all directions, otherwise, the safety function will be impaired.
- Never reach beneath the pressure plate on purpose!
- Never use two fingers to reach opposite to, parallel or centred beneath the clamping plate!





Fig. 6-145 Remote control, hold-down device

Movement up and down is controlled wirelessly via a small hand-held radio transmitter.

The operating status of the hold-down device is shown on the switch box of the protection hood support.

Yellow lamp: Cylinder pressurised

White lamp: Cylinder not under tension

If the remote control fails, the hold-down device can be controlled directly by pressing the illuminated push button.

### Pneumatic hold-down device



Fig. 6-146 Pneumatic hold-down device

The split hold-down beam can be controlled separately. This ensures optimum adjustment to differing workpiece lengths with one or both hold-down beams. The hold-down beam stroke is 80 mm; the customer-provided pneumatic connection is 6 bar.

The customer must provide a pneumatic connection of 6 bar.

Sliding table length [mm]	Beam length [mm]
2250	1975
3000	2725
3200	2925
3400	3125
3800	3525

Tbl. 6-1 Beam length

### Operation

The pneumatic hold-down beam consists of two segments and can be operated by 2 control levers to ensure optimum holding down of different workpiece lengths.

When valve V1 has been actuated, the two compressed-air cylinders lower the short part of the hold-down beam onto the workpiece.

The entire length of the hold-down beam is controlled via valve V2. After actuation, the two segments of the pressure beam are lowered simultaneously. The rubber coating of the hold-down beam prevents the workpiece from slipping.

### **Installation**

- Place the hold-down beam onto the sliding table.
- Insert the two T-nuts into the sliding table groove.
- Align the hold-down beam in parallel with the protection hood.
- The distance between the hold-down beam and the protection hood should be 15 mm; the length of the slots prevents contact with the protection hood.
- Tighten the M12 nuts.
- Connect the compressed-air supply to the air servicing unit, and set the pressure reducer to 3 bar.

www.DaltonsWadkin.com

### Vacuum fastening in the sliding table



Fig. 6-147 Suction cup rows

A vacuum is generated in one or more suction cup rows via a high-capacity vacuum pump to reliably hold the workpiece on the sliding table. Each suction area can be individually controlled, the workpiece can be released at the press of a button.

**Note!**

***Separate instructions are enclosed for the selected option Vacuum fastening!***

### 6.6.9 Cross-slide width extension



Fig. 6-148 Cross-slide width extension

The cross-slide width extension is intended to facilitate work with large format or long workpieces. It extends the width of the workpiece support surface to max. 700 mm by means of two telescopic tubes. Long boards can be securely loaded and crosscut. The additional horizontal roller allows the workpiece to be easily pushed throughout the entire length.

## 6 Operating

### 6.6.10 Additional cross-slide



Fig. 6-149 Additional cross-slide

Optional equipment for optimum support extension for large format or particularly unwieldy boards. The additional cross-slide can be easily fitted at any point of the sliding table due to its quick-action clamping system.

Max. workpiece weight up to 250 kg.

The guide is not supplied as standard with the machine!

### 6.6.11 LASER cutting line display

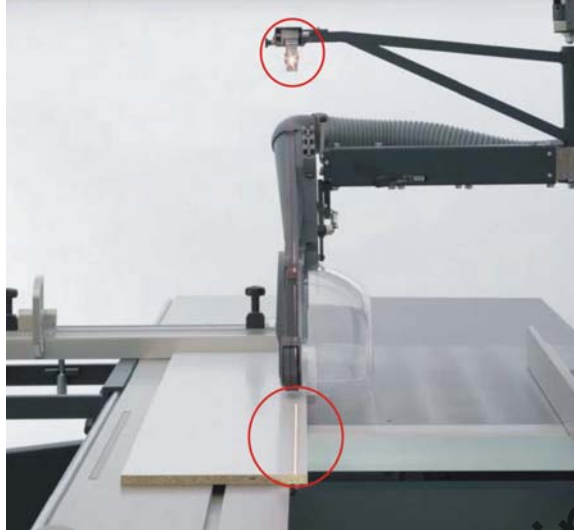

Fig. 6-150 Laser cutting line display

The laser beam shows the run of the cutting line over a length of approx. 5000 mm. For trimming or cutting along a marked line (e.g. for stairs/steps) in particular, valuable set-up time and material can be saved.



#### Warning!

##### Laser beams!

The laser creates a red luminous beam with a width of approx. 3 mm. The intensity of this laser is sufficiently low that looking into it briefly is harmless. The eye is protected by its natural reflex to close.

Never observe the laser beam using optical aids or instruments, e.g. glasses, binoculars or magnifying glasses etc. which could bundle the light, and then possibly damage the eye.

- Never attach mirror surfaces in the laser area!
- Never carry out any modifications to the laser optics!
- Furthermore, make sure that the warning signs attached to the laser are always legible. They must not be removed!
- Never replace the laser with a laser unit of a different type!
- Defective laser units may only be repaired by the manufacturer!

### Aligning the laser beam with the cutting line

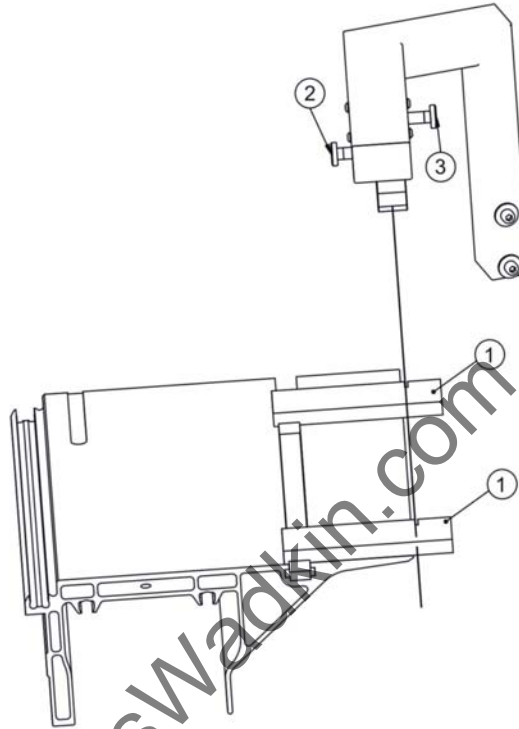

Fig. 6-151 Aligning the laser

At the factory the laser is set so that the beam is perpendicular and parallel to the sliding table.

When the hood has been swung away and this has been followed by positioning, it is necessary to check and possibly correct the laser settings.

Setting:

- Place wooden gauges (1) in the sliding table groove, and saw for approx. 15 mm
- Set the laser beam parallel to the cutting line with the left setscrew (2)
- Move the laser in parallel with the right-hand setscrew (3) until the beam aligns with the cutting line



### 6.6.12 Coolant spray device



Fig. 6-152 Coolant spray device

To improve the cutting quality, we recommend the use of a coolant spray device for plastics with a low melting point and for certain light metal alloys, especially in conjunction with the infinitely variable speed adjustment.

A sensor is fitted in the front table strip to detect the workpiece. It will interrupt the coolant supply when not obstructed by a workpiece.

#### Note!



*Separate instructions are enclosed for the selected option Coolant spray device.*

### 6.6.13 TIP-SERVO-DRIVE



Fig. 6-153 TIP-SERVO-DRIVE

The drive serves to assist the operator during sawing and is activated as soon as the joystick fitted on the sliding table is actuated (pressing = forward, pulling = backward). Operation is carried out from the usual workplace of the machine upstream of the sliding table.

**Note!**

*Separate instructions are enclosed for the selected option TIP-SERVO-DRIVE.*

## 7 Cleaning/care

### 7.1 Safety measures



---

#### Attention!

- ***Always turn off the main switch and secure it against being turned on again before doing any maintenance work!***
  - ***Before using solvents and cleaning agents, make sure that these substances do not cause damage to the painted, anodised or galvanised surfaces as well as plastic parts. For information on these substances, please refer to the safety data sheets available from the manufacturers of the solvents or cleaning agents.***
- 

www.DaltonsWadkin.com

## 7 Cleaning/care

### 7.2 Maintenance/cleaning by the user



#### Note!

Regular cleaning of the **machine** and the **machine environment** prolongs the life of the machine, is prerequisite for perfect cutting results and reduces the risk of accidents.

Pay attention to the following:

- Machine table
- Sliding table
- Sliding table guides
- Tilt segments
- Stop bar of rip fence
- Machine interior
- Machine environment

Carry out cleaning/care measures as follows:

*Regularly:*



Fig. 7-1 Remove chips and dust from the **sliding table + machine table** with a brush



Fig. 7-2 Remove chips from the **bottom carriage of the sliding table**

**Once a month:  
Sliding table**



Fig. 7-3 Remove dirt and resin residue from the **guide of the sliding table** using a cloth soaked in spirit



Fig. 7-4 Remove dirt from the **bottom of the guide of the sliding table**



Fig. 7-5 Dirt from the bottom of the sliding table guide



## 7 Cleaning/care

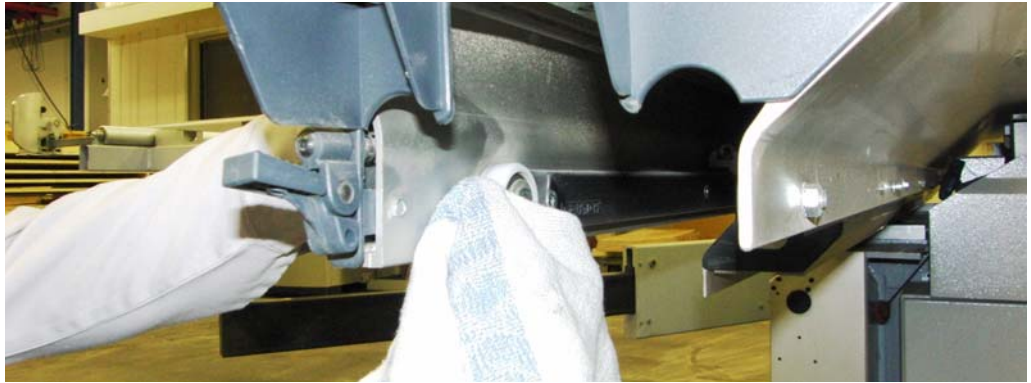

Fig. 7-6 Cleaning of the **sub-rollers** of the sliding table

### **Swinging arm**



Fig. 7-7 Open the **swinging arm** compartment



Fig. 7-8 Clean the roller



Fig. 7-9 Clean the roller from below

**Note!**



DO NOT APPLY OIL TO THE SWINGING ARM, just clean (dry)!

**Segments**



Fig. 7-10 Remove chips/dirt from the **tilt segments** (right and left-hand side) and spray with universal oil

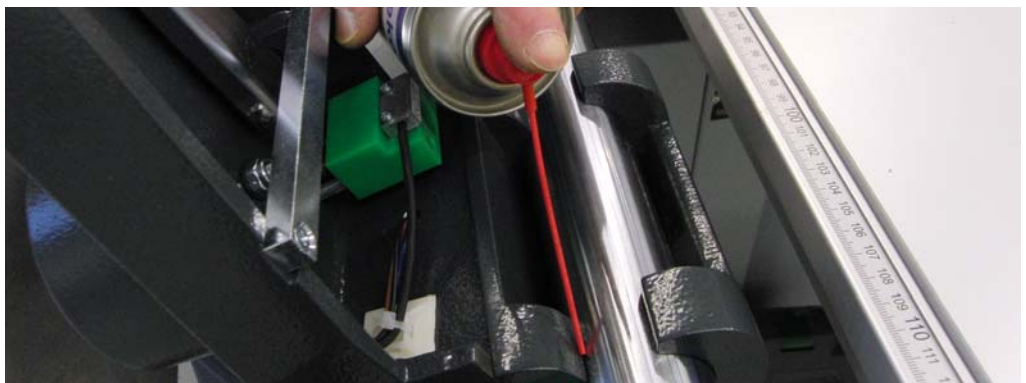

Fig. 7-11 Spray round bar. Subsequently move the block up and down.

7 Cleaning/care

**Every 6 months**  
**Sliding table**



Fig. 7-12 Spray guides with universal oil

**Note!**



Remove the oil from all lubricated points using a cloth!

**Note!**



Clean the monitor controls/screen using screen cleaning equipment such as a microfibre cloth, cleaning spray or cleaning pad (available from PC or mobile phone shops).

Type of soiling	Remove/clean with
Chips and dust	Vacuum cleaner, brush, cleaning cloth
Resin residue	Nitro thinner
Resin residue <i>on the sliding table guide</i>	Cleaning cloth, petroleum, spirit
On the monitor	Microfibre cloth, display cleaning spray or pad
Avoidance of	Necessary subsequent treatment
Rust formation	Universal oil





---

**Warning!**

NEVER APPLY RESIN REMOVER TO ANODIZED SURFACES!

- Do not allow resin removing cleaning agents to corrode the aluminium surfaces!
  - It is very important to adhere to the manufacturer's specifications!
- 

www.DaltonsWadkin.com

### Quantity of lubricant

When lubricating, **max. 5 strokes** are required for applying the required 7 g of lubricant.

The filled grease gun is included in the scope of delivery.



### Attention!

- Adhere to the precise lubricant quantity and time interval specified for each relubrication cycle.
- Excessive lubrication as a result of shorter intervals and/or too much lubricant will lead to malfunctions!



### Note!

If you want to save time and money, sign up for the annual Altendorf *inspection*, the "check-up" for your sliding table saw.

The lubrication measures will be carried out by our maintenance staff within the framework of the professional maintenance.

### Motor driven rip fence (X axis)

The rail guide is lubricated via lubricating nipples on the carriage.

### Time interval

After travel of 1500 m a message is shown on the display indicating that relubrication is necessary.

Lubrication is necessary every 12 months, irrespective of the distance travelled.

### Clearing the message

*To temporarily clear the message:* Actuate the STOP button.

After 10 adjustments or an interruption to the power, the message reappears!

*To clear the message after lubrication:* Press the START button 3x

Remove the protective cover and relubricate the lubricating nipples with the provided grease gun.



**Warning!**

Turn off the main switch before removing the cover plate!

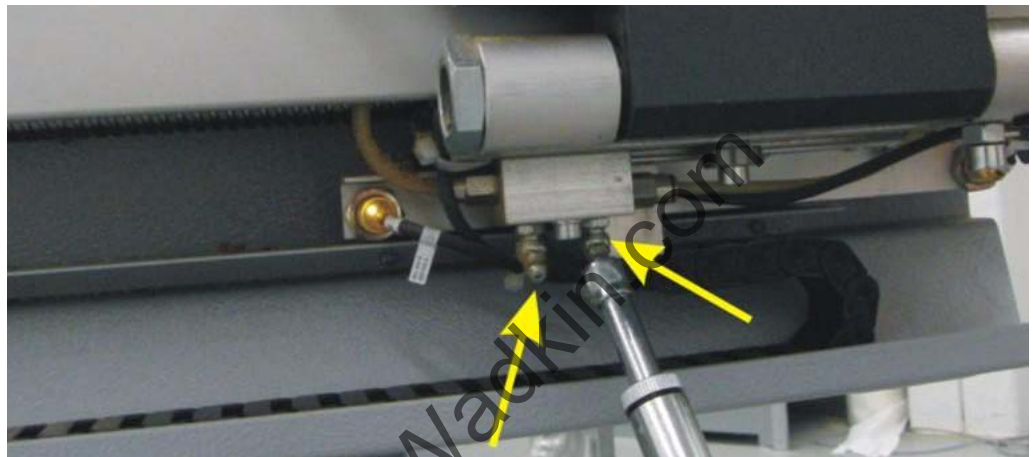

Fig. 7-13 Lubricating nipple, linear guide X axis

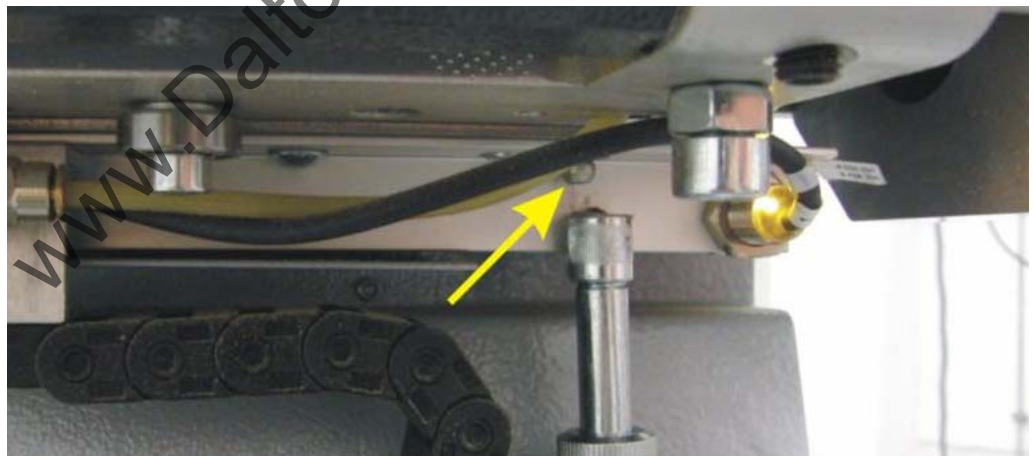

Fig. 7-14 Lubricating nipple, spindle drive F45

### Lubrication of the main saw

#### **Time interval:**

After a travel path of 100 m has been reached, a message is shown on the display indicating that relubrication of the height adjustment unit is necessary. Lubrication is necessary once a year, irrespective of the distance travelled.

#### **How to proceed:**

To relubricate, set the tilt of the saw blade to 45° and the cutting height to 0 mm. Open the machine door or remove the protective cover plate (VARIO). This allows optimum access to the lubricating nipples.



Fig. 7-15 Lubricating nipple (1) height adjustment

Remove any emerging grease and chips from the guides (2).

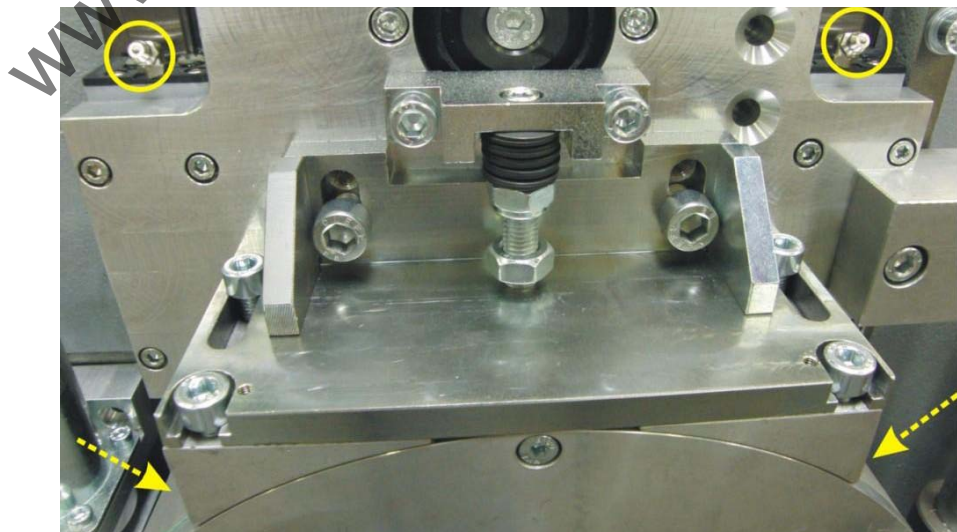

Fig. 7-16 Lubricating nipples, saw unit tilting to both sides

### Lubricating the scorer

**Note!**



Lubricating the scorer is only required for machines tilting to both sides (option).



Fig. 7-17 Lubricating nipple, scorer

**Note!**



No relubrication of the saw shaft is necessary!

## 7 Cleaning/care

### Choice of lubricants

Lubricant	Manufacturer
Aralub HL 2	Aral
BEACON 2	Esso
BP Energrease LS 2	BP
ELF ROLEXA 2	Elf
Gulfcrown Grease No. 2	Gulf
Marson EPL 2	Wintershall
Shell Alvania grease R 2	Shell
Extreme pressure-bearing grease LGEP 2	SKF
Way Lubricant 220	Texaco

Tbl. 7-1 Choice of lubricants



### Attention!

***Lubricants containing graphite or MoS<sub>2</sub> additives are not allowed to be used!***

### 7.3 Maintenance/cleaning by qualified persons

#### 7.3.1 Checking the winding shield

##### Checking the winding shield

The resistance of the PTC resistors must be checked in the motor terminal box by an electrician at least once a year. Resistance must be measured with a cold motor, and should be 750 ohms  $\pm$  200 ohms.

www.DaltonsWadkin.com



## 8 Faults/problems/troubleshooting

### 8.1 Machine diagnosis

The display shows when limit switches have been actuated at protective devices and so on. There are two function groups.

Function group 1:

- Motor temperature
- Machine door
- Lower saw blade cover
- EMERGENCY STOP button
- Sliding table limit switch

Function group 2:

- Brake unit

Response by function group 1:

Machine drives are switched off or cannot be started

Response by function group 2:

Machines will not start

Indication to request a service technician to check the functioning



## 8.2 Motor overload protection

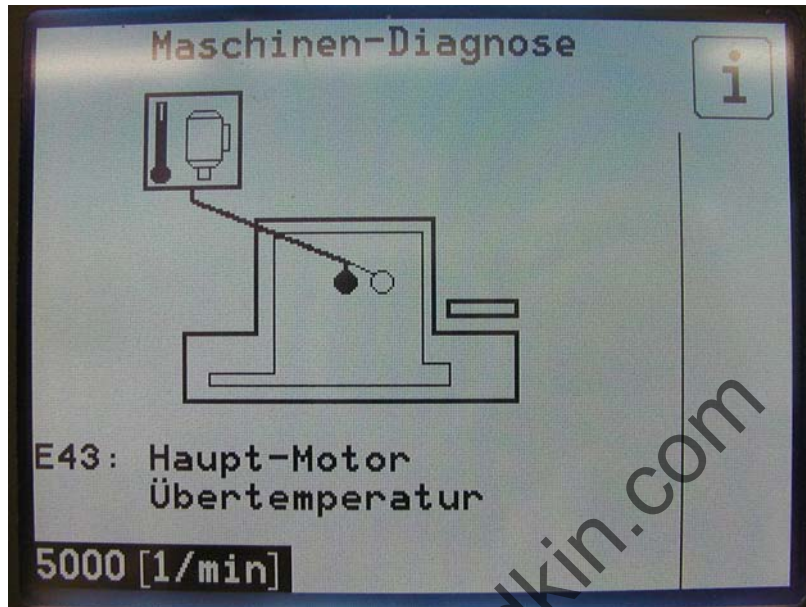

Fig. 8-1 Motor overload protection

The drive motors are protected against overload by a winding shield. This switches a motor off automatically if it overheats. In the case of machines equipped with a scorer, the scorer drive is also switched off even if this motor was not overloaded. The motor can only be switched on again when it has cooled down. It may take several minutes (max. 10) for the motor to cool down!

## 8 Faults/problems/troubleshooting

### 8.3 Troubleshooting/faults/messages

Fault	Cause	Troubleshooting
The machine cannot be switched on.	<p>The main switch is not turned on.</p> <p>Power failure or phase failure</p> <p>Overload protection has responded.</p> <p>Sliding table moved over saw blade centre line.</p> <p>EMERGENCY STOP button pressed.</p> <p>Door in machine frame or lower base plate in front of saw blades opened.</p> <p>Control circuit fuses defective</p>	<p>Turn the main switch to switch position "I".</p> <p>Wait for power to be reinstated, or eliminate cause for loss of power, check factory fuses.</p> <p>Allow motor to cool down, also refer to machine diagnosis display.</p> <p>Move the sliding table back to the saw blade centre line; also refer to machine diagnosis display.</p> <p>Rearm the EMERGENCY STOP button again by pulling, also refer to machine diagnosis display.</p> <p>Close the machine door or cover plate; also refer to machine diagnosis display.</p> <p>Turn off the main switch, open the switch cabinet and identify which of the fuses F1, F2, F8 is defective. Find and eliminate the cause. Replace defective fuses, only using fuses of the same rating!</p>
The machine switches off automatically during operation.	<p>Power failure in one or several phases due to responding factory fuses.</p> <p>Overload protection has responded due to blunt saw blade or excessive feed speed.</p>	<p>Eliminate cause of phase failure.</p> <p>Change saw blade or reduce feed speed. Allow motor to cool down, also refer to machine diagnosis display.</p>
	Control circuit fuses defective	Turn off the main switch, open the switch cabinet and identify which of the fuses F1, F2, F8 is defective. Find and eliminate the cause. Replace defective fuses, only using fuses of the same rating!
Workpiece jammed while feeding forward.	<p>Blunt saw blade</p> <p>Riving knife thickness does not match the saw blade used.</p>	<p>Fit a sharp saw blade.</p> <p>Fit the correct riving knife; it must be thicker than or equal to the thickness of the main saw blade.</p>

<b>Fault</b>	<b>Cause</b>	<b>Troubleshooting</b>
The finished size of the cut workpiece does not match the cutting width set on the rip fence.	Dimension scale for cutting width display is misadjusted.  Incorrect calibration for DIGIT_X, CONTROL	Reset the dimension scale: Cut a workpiece at the rip fence, precisely measure the cut width and position the measuring scale so that the measured cutting width is displayed on the fence edge.  Recalibrate
The finished size of the cut workpiece does not match the cutting width set on the crosscut stop.	Dimension scale for cutting width display is misadjusted.  Incorrect calibration for DIGIT_X, CONTROL	Reset the dimension scale: Cut a workpiece at the crosscut stop, precisely measure the cut width and position the measuring scale so that the magnifying glass display matches the measured cut width.  Recalibrate
Swinging arm does not move smoothly.	Soiled telescopic tube or track rollers	Clean telescopic tube or track rollers; check wiper.
Sliding table has lateral play.	Sub-rollers incorrectly set.	Set the sub-rollers.
In its end positions, the sliding table is higher than the machine table.	Sub-rollers incorrectly set.	Set the sub-rollers.
Saw blade burns on the sliding table side.	Insufficient free cut on sliding table  Excessive free cut on the rip fence	Readjust the free cut.  Readjust the rip fence.
Saw blade burns on the rip fence side.	Insufficient free cut on rip fence	Readjust the free cut.
Saw blade burns on both sides.	Incorrect free cut setting.  Workpiece jammed.  Operating error	Readjust the free cuts.  Insert a riving knife in the cutting line or use a wider riving knife.  Guide the workpiece either at the LH or the RH fence. Do not guide the workpiece on the rip fence when cutting with the sliding table.
Workpiece has burn marks.	Blunt saw blade	Change the saw blade.

## 8 Faults/problems/troubleshooting

Fault	Cause	Troubleshooting
	Feed too low	Increase the feed rate.
	Saw blade has too many teeth.	Change the saw blade.
	Incorrect free cut	Readjust the free cut.
Break-outs in spite of scorer	Scorer not aligned with main saw blade	Readjust free cuts; the free cut should be almost "0".
	Scoring blade too narrow	Adjust saw width.
Workpiece rises when cut with the scorer.	Blunt scoring blade	Exchange the sawing blade.
	Cutting height too low	Set the scoring blade higher.

Tbl. 8-1 Fault

Fault message	Cause	Troubleshooting
B000 - B063	Internal faults	Request a service technician to check the function.
E01	Limit switch ES_MIN1 reached	
E02	Limit switch ES_MIN2 reached	
E03	Limit switch ES_MAX reached	
E06	Fault, collision, fast shutdown	
E07	Drive positioning fault	
E08	Axis reference run error	Perform new reference run
E18	Fresh oil lubricator empty	Change cartridge
E21	Error during update: File error on the USB stick	
E22	Error during update: File errors on the USB stick (various)	
E40	20VAC control voltage missing	Check fuse F9
E41	24VAC control voltage missing	Check fuse F8

Fault message	Cause	Troubleshooting
E42	Scoring saw motor overheated	Allow motor to cool down.
E43	Main saw motor overheated	Allow motor to cool down.
E44	Sliding table limit switch	
E45	Saw blade cover open	
E46	Machine door open	
E47	EMERGENCY STOP button 1 pressed	
E48	EMERGENCY STOP button 2 pressed	
E49	EMERGENCY STOP button 3 pressed	
E51	Brake unit fault: Phase failure/rotational direction	Check fusing in the factory and fuses F15 / F16.
E53	Brake unit fault: Mains contactor not in neutral position.	Request a service technician to perform a repair.
E54	Operating error, incorrect riving knife position or speed setting, e.g. too fast for 450 mm saw blade. Drives cannot be started!	Check rotational speed and riving knife position.
E55	Brake unit fault: Communication problem with machine control unit - brake unit is operating in default mode, 450 mm saw blade / 4000 rpm.	Request a service technician to check the function.
E56	Frequency converter phase failure/overvoltage	Press any button on the control unit.
E57	Frequency converter excessive speed	Restart the machine. If this does not remedy the fault, request a service technician.
E58	Frequency converter communication fault	Request a service technician to check the function.
E59	Emergency running block 3500 rpm	Switch the main saw blade off and on again.
E61	Malfunction, drive positioning, current consumption evaluation	Lubricate the axle

## 8 Faults/problems/troubleshooting

Fault message	Cause	Troubleshooting
E81	Malfunction, shaft encoder A/B channel evaluation error	Request a service technician to check the function.
E91K	K contact error of the STOP button	If the fault occurs repeatedly, request a service technician to check the function.
E92	K-n stop signal missing Check the AC stop circuit	Request a service technician to check the function.
E93K	K contact error of the START button	If the fault occurs repeatedly, request a service technician to check the function.
E94	K free signal missing	Request a service technician to check the function.
E99	Excess temperature of the control electronics	Switch off machine and allow to cool down before restarting. If fault occurs again, request a service technician to check the function.

Tbl. 8-2 Fault messages

#### **8.4 Electronic brake module**

The main saw shaft is braked with an electronic brake module. This brake module is located in the contractor control housing, and is accessible when the rear panels have been removed. Braking is controlled in such a way that there is a high brake current at the beginning of braking. This is reduced over time to ensure smooth braking. In addition, a standstill monitoring facility switches off the brake current if the motor is standing still. The brake module contains various function blocks for control and monitoring tasks. There is also a communications connection for machine control.

www.DaltonsWadkin.com

## 9 Technical data

### 9 Technical data

#### 9.1 Standard equipment

**Saw blade heights:** Standard up to 450 mm

Features
<p><b>Electromotive height and tilt adjustment 0 - 46 ° for the main saw blade</b>, for tilting in both directions from -46° to +46°, with automatic correction of the cutting height when tilting the saw unit, and with display of tilt angle and cutting height.</p>
<p><b>F45 display control system with dimension input via the keypad</b> Saving of 99 programs</p>
<p><b>Sliding table incl. infinitely variable top carriage locking</b> Sliding table length 3000 mm</p>
<p><b>Rip fence</b> Cutting width 1000 mm, table width extension, aluminium anodised</p> <ul style="list-style-type: none"> <li>• Manual adjustment with precision setting</li> </ul>
<p><b>Crosscut fence</b></p> <ul style="list-style-type: none"> <li>• manual adjustment, crosscutting up to 3200 mm, 2 operating positions on the cross-slide frame</li> </ul>
<p><b>Drive power / rotational speed of main saw shaft</b> With automatic brake and display of rotational speed</p> <ul style="list-style-type: none"> <li>• 4kW (5.5 PS) with a rotational speed of 4200 rpm</li> </ul>
<p><b>Tool clamping system</b> for main saw blade</p>
<p><b>Max. cutting height 150 mm, max. saw blade diameter 450 mm</b> Cutting heights: see table</p>
<p><b>Table length extension</b> 840 mm, aluminium anodised</p>
<p><b>USB-A port for data and program transfer</b></p>
<p><b>Machine diagnosis and operating hours meter</b></p>
<p><b>Aluminium parts in anodised finish</b></p>
<p><b>Clamping shoe, push stick, push block handle and pull-back handle</b></p>



Saw blade diameter [mm]	Standard			Option: Extended cutting height		
	0°	+ 45°	- 45°	0°	+ 45°	- 45°
250	0 - 55	0 - 30	0 - 1	0 - 55	0 - 30	0 - 1
300	0 - 80	0 - 47	0 - 18	0 - 80	0 - 47	0 - 18
350	0 - 105	0 - 64	0 - 35	0 - 105	0 - 64	2,5 - 35
400	0 - 130	0 - 81	2 - 52	25 - 130	17,5 - 81	20,5 - 52
450	25 - 155	16 - 98	20 - 69	50 - 155	35,5 - 98	38 - 69
500	-----	-----	-----	75 - 180	53 - 115	56 - 86
550	-----	-----	-----	100 - 205	70,5 - 132	73,5 - 103

**Note!**

1) For machines with a scoring unit, the scoring blade, including the front and rear flange, or RAPIDO must be removed.

## 9 Technical data

### Technical data:

<b>Main saw</b>	Tool holder diameter	30 mm
	Saw blade tilting range	0-46°
	Idling speed	4000 rpm
	Tool edge width	max.20 mm
<b>Sliding table</b>	Sliding table cutting length	See table
<b>Crosscut fence</b>	Crosscutting at 90° crosscut fence	3200 mm
<b>Rip fence</b>	Cutting width at rip fence	1000
<b>Extraction</b>	Connection socket diameter below table	120 mm
	Connection socket diameter at top safety hood	80 mm
	Overall vacuum connection $\varnothing$ 140 mm	1500 PA
	Air speed	20 m/s
	Minimum air volume	1150 m <sup>3</sup> /h
<b>Ambient conditions</b>	Operating temperature	10 - 40 °C
	Max. relative humidity <b><i>Do not expose the machine to a gaseous environment which is explosive or may cause corrosion!</i></b>	90 %, no condensation



<b>Weight</b>	Machine weight, dependent upon equipment	Approx. 1100 kg
<b>Electrical equipment</b>	Lockable main switch	
	Contactor control with pushbutton operation	Control voltage 24 VAC
	Rotational speed, tilt angle, cutting height	Digital display
	Braking of main motor, monitoring of winding temperature	Electronic multifunction module/frequency converter
	Adjustment of tilt and cutting height for the main saw	CNC-controlled

**Sliding table cutting lengths**

Maximum cutting length with use of clamping shoe or crosscut-mitre fence  
Does not apply to crosscut fence, crosscutting up to 2500 mm.

Sliding table length [mm]	2250	3000	3200	3400	3800	4300	5000
Cutting length [mm] for WA,WGA,PQS, UNO	2155	2905	3105	3305	3705	3705	3705
Cutting length [mm] for DUO and DUO Flex	2100	2850	3050	3250	3650	3650	3650
<b>TIP-SERVO-DRIVE</b>							
Cutting length [mm] without scoring blade	1840	2590	2790	2990	3390	3870	3870
Cutting length [mm] with scoring blade	1725	2475	2675	2875	3275	3775	3775

## 9 Technical data

### 9.2 Special equipment

Available special equipment
<p><b>Main saw drive</b></p> <p>Heavy-duty motors up to 11 kW (for machines tilting to one side)</p> <p>Infinite rotational speed adjustment (VARIO, adjustable in increments of 5, power for machines tilting to one side: 5.5kW, 7.5kW , power for machines tilting to both sides: 5kW and 6.5 kW)</p>
<p><b>Sliding table</b></p> <p>Sliding table lengths from 2250 mm to 5000 mm</p> <p>Second support (STEG), support width extension by 400 mm</p> <p>On/Off switch at the end of the sliding table</p>
<p><b>Crosscut-mitre fence</b></p> <p>Length dimension adjustable via digital display with fine adjustment (DIGIT L), setting accuracy 0.1 mm, crosscutting up to 3200 mm</p> <p>Length dimension, angle, length compensation via digital display (DIGIT LD), setting accuracy 0.1 mm / 0.1°, crosscutting up to 3200 mm</p>
<p><b>Mitre fences</b></p> <p>One-sided mitre fence, angle adjustable via scale from - 30° to 45°, crosscutting up to 2500 mm</p> <p>Double-sided mitre fence (DUPLEX), angle adjustable via scale from 0° to 90°, crosscutting up to 1350 mm or 2150 mm, length compensation</p> <p>Double-sided mitre fence (DUPLEX D), angle digitally adjustable, setting accuracy 0.01°, crosscutting up to 1350 mm or 2150 mm, length compensation</p> <p>Double-sided mitre fence (DUPLEX DD), angle and length digitally adjustable, setting accuracy 0.01° / 0.1 mm, length display is adapted automatically in accordance with the angle that is set, crosscutting up to 1350 mm or 2150 mm</p>
<p><b>Rip fence</b></p> <p>With digital dimension display and fine adjustment, setting accuracy 0.1 mm</p>
<p><b>Parallel cutting device</b></p> <p>Parallel cutting device (PALIN), crosscutting up to 900 mm, adjustable via scale</p> <p>Parallel cutting device (PALIN_D), crosscutting up to 900 mm, digitally adjustable, setting accuracy 0.1 mm</p>

Available special equipment
<p><b>Pneumatic hold-down beam</b></p> <p>For sliding table length 2250 mm, clamping length 1975 mm            For sliding table length 3000 mm, clamping length 2725 mm            For sliding table length 3200 mm, clamping length 2925 mm            For sliding table length 3400 mm, clamping length 3125 mm            For sliding table length 3800 mm, clamping length 3525 mm            Max. clamping height 80 mm, min. pneumatic connection 6 bars</p>
<p><b>Electro-pneumatic hold-down device</b></p> <p>with 1 cylinder            with 2 cylinders            Max. workpiece height 0 – 90 mm or 80 – 170 mm, min. pneumatic connection 6 bar, wireless remote control</p>
<p><b>Manual quick-action clamp</b></p> <p>Max. clamping height 175 mm</p>
<p><b>Cross-slide</b></p> <p>Telescopic cross-slide width extension for up to 700 mm extra            Additional cross-slide with floor supporting roller, max. workpiece weight 250 kg</p>
<p><b>LASER cutting line display</b></p> <p>Light beam width approx. 3 mm, light beam length approx. 5 m</p>
<p><b>Three-phase A/C socket</b></p> <p>In European standard version, fuses 10 A, can be switched via the main switch</p>
<p><b>Coolant spray device</b></p> <p>Minimal cooling lubrication, operating pressure 0.5 – 5 bars</p>
<p><b>Support roller, tilting</b></p> <p>Positioned on the sliding table in front of the machine table</p>
<p><b>Parallelogram cross-slide</b></p> <p>Additional cross-slide with digital display</p>
<p><b>Vacuum suction cup in sliding table</b></p> <p>5 individually selectable suction areas for all table lengths</p>

## 10 Maintenance and repairs

### 10.1 General

Keeping a supply of the most important spare and wear parts on site is an important prerequisite for the constant functioning and operating capability of the sliding table saw. We only accept a guarantee for original spare parts supplied by us. We expressly point out that original spare parts and accessories not supplied by us have not been checked and released by us. Therefore, the fitting and/or use of such products may negatively influence the properties of the sliding table saw and thus impair its active and/or passive safety. Wilhelm Altendorf GmbH&Co. KG will not accept any liability or guarantee for damage resulting from the use of non-original spare parts and accessories.

Please note that special production and delivery specifications exist for our own and our suppliers' parts, and that we always supply spare parts that meet the latest state of the art and comply with the latest statutory regulations.

Please refer to the spare parts list when ordering spare parts.

For further information please refer to the spare parts drawings included in the spare parts list.

When ordering spare parts, please state the following information:

- Machine no.
- Article no.

## 10.2 Customer service addresses

Wilhelm Altendorf GmbH & Co KG  
Service department

Wettinerallee 43/45  
D-32429 Minden

Post office box  
D-32377

Phone: +49 571 9550222  
Telefax: +49 571 9550111  
e-Mail: [service@altendorf.de](mailto:service@altendorf.de)  
[www.altendorf.com](http://www.altendorf.com)

[www.DaltonsWadkin.com](http://www.DaltonsWadkin.com)