

Wadkin

COMBINED DISC AND BOBBIN SANDER, TYPE J. T. A.

PRINCIPAL DIMENSIONS AND CAPACITIES :

	English	Metric
Diameter of disc	30"	760 mm
Bobbin supplied with the machine	3½" diameter 9½" long	90 mm diameter, 241mm long
Maximum depth bobbin will sandpaper	7"	178 mm
Maximum diameter of bobbin	5"	127 mm
Minimum diameter of bobbin	2"	50 mm
Bobbin spindle	1¼" diameter, 11" long	31.75 mm diameter, 280 mm long
Size of disc table	2'10" x 1'5"	865 mm x 430 mm
Disc table cants 45° below and 10° above horizontal.		
Lateral adjustment of table from face to disc.	3"	76 mm
Height of disc table from floor level	2'10½"	875 mm
Size of bobbin table	2'2" x 2'1½"	660 mm x 650 mm
Bobbin table cants 30° below and 10° above horizontal.		
Height of bobbin table from floor level	3'1½"	950 mm
Floor space without dust collector.	5'6" x 2'10"	1675 mm x 865 mm
Motor for disc	4 H. P. - 900 r. p. m.	4 H. P. - 900 r. p. m.
Motor for bobbin	1½ H. P. - 3,000 r. p. m. on 50 cycles 3,600 r. p. m. on 60 cycles	1½ H. P. - 3,000 r. p. m. on 50 cycles 3,600 r. p. m. on 60 cycles
Net weight in cwts. without dust collector	18 (2016 lbs)	915 kilos
Net weight in cwts. with dust collector	21¼ (2380 lbs)	1,080 kilos
Shipping dimensions in cubic feet without dust collector	80	2.27 cu. meters
Shipping dimensions in cubic feet with dust collector	152	4.3 cu. meters

DETAILS INCLUDED WITH THE MACHINE :

Control gear for motors	Dust exhaust hood and guard to disc
One steel disc 30" diameter	Dust exhaust connection to bobbin
One split metal bobbin, 3½" diameter	Disc press and two spare steel discs
One filling-in ring in table for 3½" bobbin	One set of spanners
One universal swivelling fence.	Lubricating pump and tin of ball bearing lubricant.

INSTALLATION

The machine is despatched from the Works with all bright surfaces greased to prevent rusting. This must be removed by applying a cloth damped in paraffin or turpentine.

FOUNDATIONS.

Foundation bolts are not supplied by Wadkin Ltd. unless specially ordered. 5/8" (16 mm) diameter rag bolts should be used to fix the machine to the floor. If the mill floor consists of 4" (100 mm) to 6" (150 mm) solid concrete no special foundation is necessary. Cut 4" (100 mm) to 6" (150 mm) square holes in the concrete. When the machine has been carefully levelled it should be grouted in position with liquid cement.

WIRING

For cabling instructions see wiring diagram D. 658 on page 10.

DUST EXTRACTION.

The machine has a built in exhaust hood for the disc which has a 7¼" (185 mm) diameter outlet for piping connections. A hopper is formed in the bobbin table itself for the bobbin with a 3½" (90 mm) diameter outlet for piping connections.

LUBRICATION.

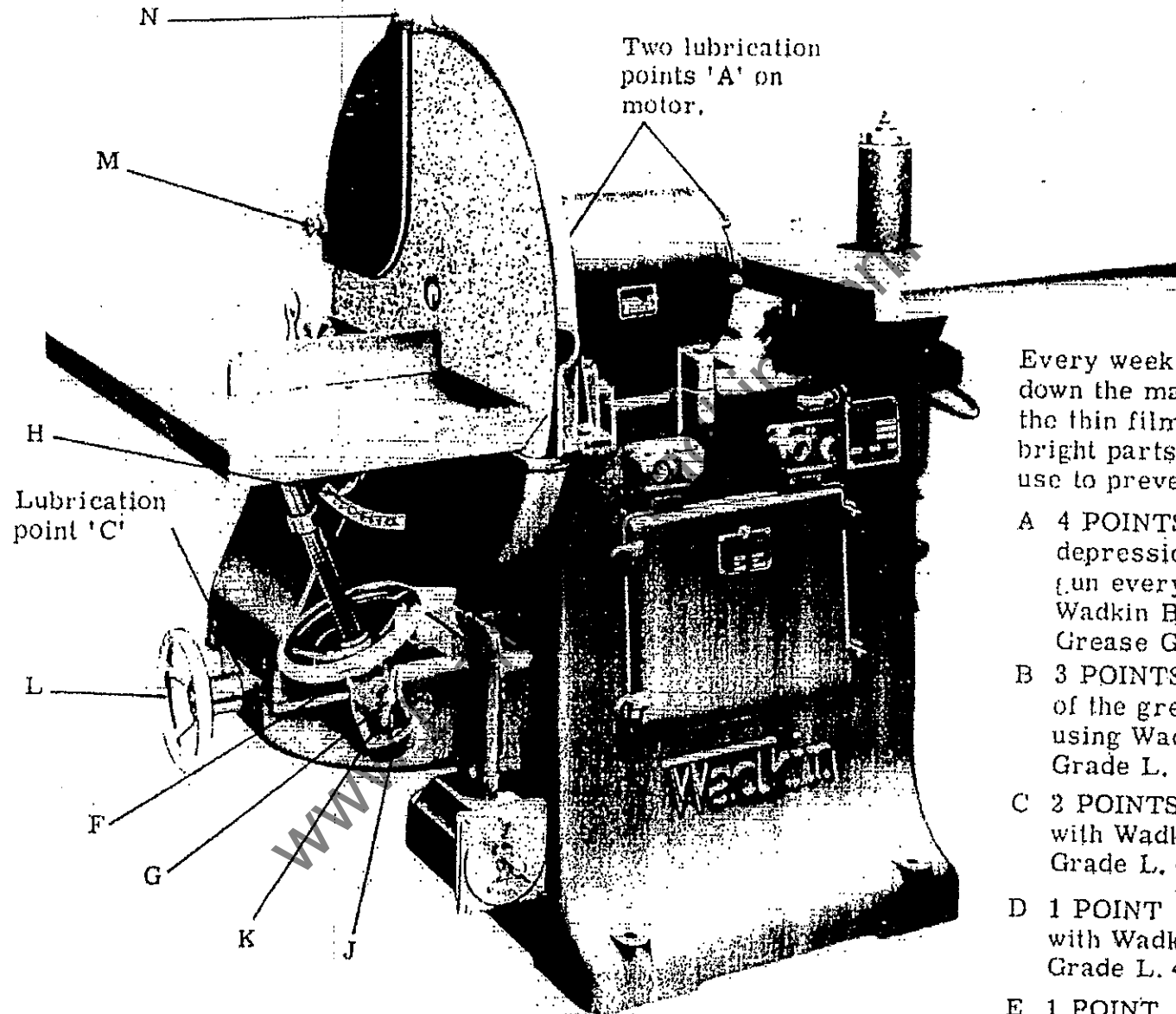

Two lubrication points 'A' on motor.

Lubrication point 'C'

Every week thoroughly clean down the machine and renew the thin film of oil on all bright parts not in constant use to prevent rusting.

- A 4 POINTS Give 1 or 2 depressions of the grease gun every month using Wadkin Ball Bearing Grease Grade L. 6.
- B 3 POINTS Give 1 depression of the grease gun daily using Wadkin Grease Grade L. 6.
- C 2 POINTS Oil twice weekly with Wadkin Machine Oil Grade L. 4.
- D 1 POINT Top up weekly with Wadkin Machine Oil Grade L. 4.
- E 1 POINT Inspect and top up every 3 months using Wadkin Gear Oil Grade L. 2.

FIG. 1. FRONT VIEW OF MACHINE

LUBRICATION

WADKIN RANGE OF OIL AND GREASE LUBRICANTS WITH EQUIVALENTS.

WADKIN GEAR OIL GRADE L. 2.

- (a) Shell Vitrea Oil 69
- (b) Gargoyle Oil D. T. E. /BB.
- (c) Meropa Lubricant No. 2 Oil.

WADKIN MACHINE OIL GRADE L. 4.

- (a) Shell Vitrea Oil 33.
- (b) "Vactra" Oil (Heavy Medium)
- (c) Caltex Aleph Oil.

WADKIN BALL BEARING GREASE GRADE L. 6.

- (a) Shell Nerita Grease 3.
- (b) Gargoyle Grease B. R. B. 3.
- (c) Regal Starfak No. 2 Grease.

Manufacturers :

- (a) Shell Mex & B. P. Ltd.
- (b) Vacuum Oil Co. Ltd.
- (c) Caltex Lubricants.

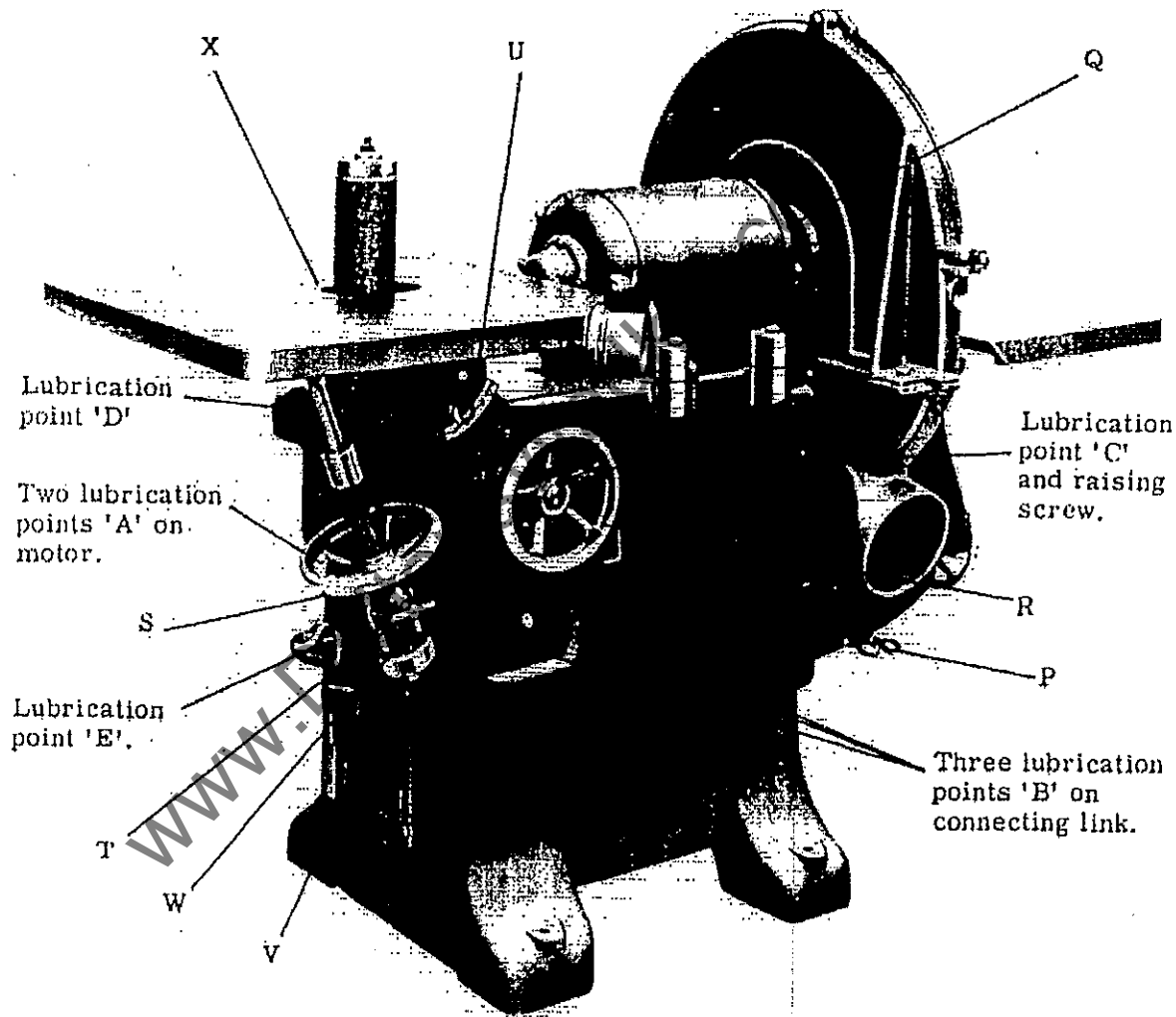

FIG. 2. REAR VIEW OF MACHINE

TO CHANGE THE ABRASIVE PAPER.

To remove a worn abrasive from the disc, immerse it in a bath of hot water and leave for ten to fifteen minutes, when the paper will peel off. While the disc is in the bath, scrape and clean off all the old solution. Remove it from the bath and allow it to dry.

When attaching a new abrasive the disc should be laid flat on a bench. Coat the surface with a thin layer of Wadkin Adhesive Cement Grade C. 5. If it is extremely cold the cement should be warmed before use. Spread to an even thickness with a roller or squeegee and leave until tacky. Afterwards put on the sheet of abrasive paper. The disc press as illustrated in Fig. 3 which is supplied complete with two sanding discs is now used. Place the newly prepared disc in the press and by the aid of the other spare disc clamp and leave for 12 hours or until required whichever is the longer.

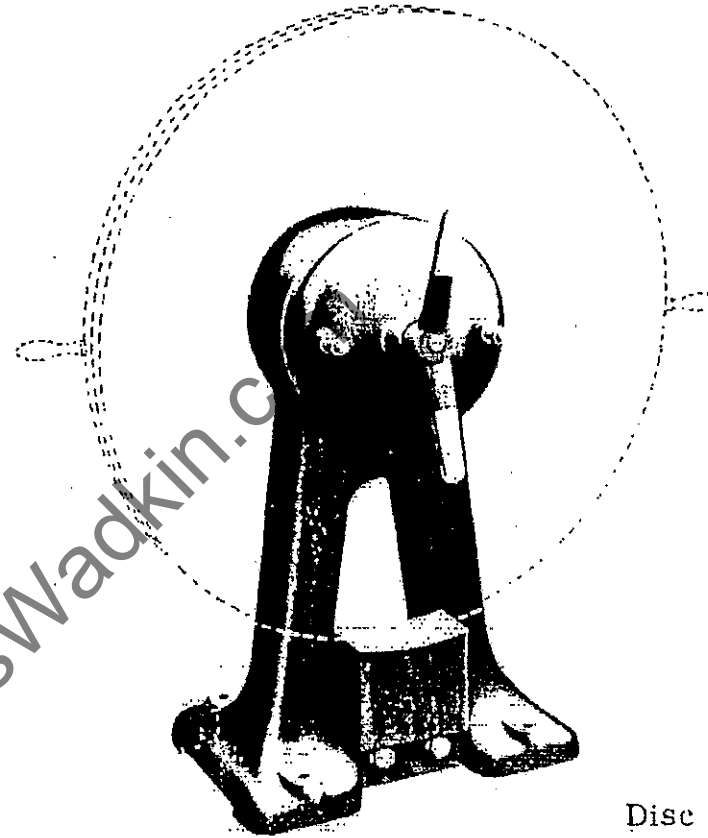

Fig. 3

Disc Press

SANDING BOBBIN.

The sanding bobbin is driven by an electric motor built direct on the vertical spindle, while a reciprocating motion is given to the bobbin by means of a worm and wormwheel drive. The gears are mounted in a totally enclosed gearbox and run in an oil bath. The carriage forming the unit is counterbalanced, while a screw adjustment is provided to enable the operator to raise or lower the bobbin slide to allow the full length of the abrasive paper to be used. This motion is operated by handwheel 'R', Fig. 2.

SANDING DISC.

The sanding disc is recessed at the back for securing to the driving flange plate which is mounted on a taper spindle. It is driven by an electric motor the shaft of which forms the disc spindle. A guard is provided.

DISC WORK TABLE.

The disc table is arranged to cant 45 degrees below and 10 degrees above the horizontal. The canting motion is controlled by handwheel 'F', Fig. 1, and screw. This movement is locked by tee locking handle 'G'. The scale 'H' and pointer registers angles in degrees. Sleeve 'J' is secured onto the end of the elevating screw and acts as a stop giving the dead horizontal position to the table on winding up from below the horizontal. When the table is canted above the horizontal the sleeve has to be turned so that the two stops 'K' will pass through the two holes in the sleeve. A horizontal adjustment to and from the disc is provided by operating handwheel 'L' which is used in conjunction with the canting mechanism and also facilitates removal of the disc.

The disc fence is of the universal swivelling type and can be fixed in any of the holes in the table to suit either right or left handed working. This method is preferred to the use of a slot across the table which can be dangerous if a piece of work is trapped between the near edge of the slot and the disc. Scales are provided for convenience in setting for angular work.

REMOVAL OF DISC.

Move the table horizontally away from the disc by rotating handwheel 'L', Fig. 1. The small knurled handwheel 'M' holding the guard in position over the face of the disc should be unscrewed. This leaves the guard free to be swung out of the way on the pivot 'N' securing it to the guard covering the back of the disc. Detach the two handles 'P', Fig. 2, from the body of the machine and screw into the holes tapped in the rim of the disc. The guard over the rim of the disc is cut out in two opposite positions to allow the handles to be inserted into the rim of the disc whilst it is still fitted to the machine. Take out the four screws 'Q'. Using the two handles lift the disc off the driving flange plate and clear of the machine.

Follow the reverse procedure when replacing the disc after a new abrasive has been attached.

NOTE: Care must be taken to remove the handles from the rim of the disc before putting the machine to use.

DUST COLLECTION.

In the case of the disc the dust is collected by a hood below the table provided with an outlet for connecting up to an exhaust system. A hopper is formed in the table itself for collection of dust from the bobbin with an outlet attached to the edge of the table for connecting to an exhaust system. If a main dust extracting system is available the machine outlets may be connected to the main suction plant.

Alternatively a compact self-contained dust collector can be supplied. This unit very efficiently handles the fine dust and is recommended where one machine only is installed. It embodies a dust storage bin of four cubic feet capacity made quickly detachable for emptying purposes. The dust laden air is filtered through a series of flame-proofed fabric sleeves, while a motorised mechanism for periodic shaking prevents accumulation of excessive dust. Full details for operating and maintenance of the unit are given on an Instruction Sheet inside the top lid of the unit.

Where a number of sanding machines are installed a separate system of dust collection quite distinct from the main suction plant is recommended. Advice on this will be given on request.

ABRASIVES.

Garnet Paper Discs and Rolls of varying grits and grades can be supplied to suit the class of work and the desired finish on woodwork. Discs of 30" diameter with a 2 $\frac{1}{4}$ " diameter centre hole are available. The abrasive for the bobbin is available in 50 yard Rolls, 9" wide.

BEARING LIST

Makers Number	Size		Width	Number Per Machine	Where used
	Bore	O/D			
Hoff. R. 545.	45 mm	120 mm	29 mm	1	Disc end of disc spindle
SKF. 1308F.	40 mm	90 mm	23 mm	1	Rear end of disc spindle
SKF. RM11F.	1 $\frac{3}{8}$ "	3 $\frac{1}{2}$ "	$\frac{7}{8}$ "	1	Top end of bobbin spindle
SKF. RM9F.	1 $\frac{1}{8}$ "	2. 13/16"	13/16"	1	Bottom end of bobbin spindle

BOBBIN TABLE.

The bobbin table is arranged to cant 30 degrees below and 10 degrees above the horizontal. The canting motion is controlled by handwheel 'S', Fig. 2, and screw, and locked by locking handle 'T'. A graduated scale 'U' and pointer indicates the angle of the table. Sleeve 'V' on the end of the elevating screw acts as a stop giving the horizontal position. When the table is canted above the horizontal the sleeve has to be turned so that the two stops 'W' will pass through the two holes in the sleeve. A loose filling in ring 'X' is provided in order to keep the table opening for the sanding bobbin as small as possible. The hopper cast in the table is the collecting point for the dust.

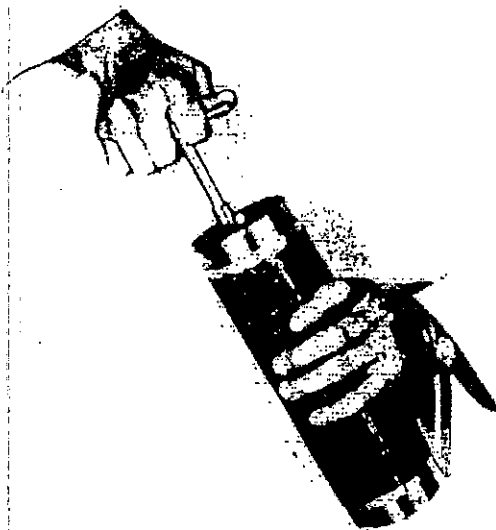

FIG. 4.

CHANGING SANDING BOBBIN AND ABRASIVE.

Unscrew the nut holding the bobbin on the spindle and withdraw the bobbin. The part carrying the paper is in two sections and the key shown in Fig. 4, is used to open the slots. When the slots are apart the abrasive can be removed. To avoid breaking the edges of a new abrasive paper they should be bent over about $\frac{1}{2}$ " on a rounded edge of a flat piece of wood. For the coarser grades of abrasive it might prove necessary to slightly dampen the edges before bending. Place the abrasive on the bobbin and close the slot with the key. The closing action stretches the paper and holds it perfectly taut. This type of sanding bobbin can be supplied in $3\frac{1}{2}$ " and 5" diameter sizes. Other sizes of metal split bobbins are available with either 2" or $2\frac{1}{2}$ " diameters.

NOTE: Oil the surfaces of the cones at each end of the tightener bolt when a new abrasive is applied.

USE WADKIN ADHESIVE CEMENT GRADE C. 5 FOR FIXING ABRASIVE PAPER TO STEEL DISCS.
IT IS SUPPLIED IN ONE GALLON TINS PREPARED READY FOR USE AND REQUIRES NO MIXING.

ELECTRICAL INSTALLATION INSTRUCTIONS

The cabling between the motor and the control gear has been carried out by Wadkin Ltd. , and it is only necessary to bring the line leads to the machine for it to be put into service. This should be done as follows :

1. Fit triple pole isolating switch near the machine unless it has been supplied to special order by Wadkin Ltd. , when it will be fitted and connected to the machine.
2. Connect the line lead to the appropriate terminals. See diagram of connections. The cables should be taken to the machine in conduit and secured to the control gear by locknuts.
3. Connect solidly to earth.
4. Close isolating switch and press start button. If motor does not rotate in the right direction, interchange any two incoming line leads.

FAILURE TO START

1. Electric supply is not available at the machine.
2. Fuses have blown or have not been fitted.
3. Isolating switch has not been closed.
4. Lock-off or stop button has not been released.

STOPPAGE DURING OPERATION AND FAILURE TO RESTART

1. Fuses have blown.
2. Overloads have tripped. They will reset automatically after a short time and the motor can be restarted in the usual manner.

ADJUSTMENTS

For a finer overload setting, set the load indicator to a lower value and vice-versa for a less fine setting.

GENERAL

Check the earth connection from time to time. Users are recommended to display in an appropriate position in the maintenance department a Wadkin Electrical Maintenance Instruction Card, No. 356, which is issued gratis on application.

MAINS SUPPLY
L1 L2 L3

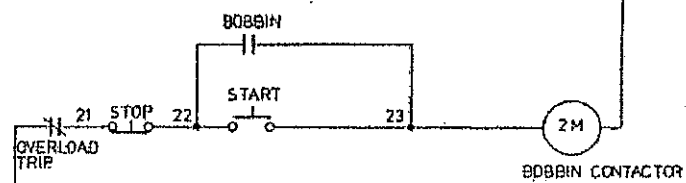
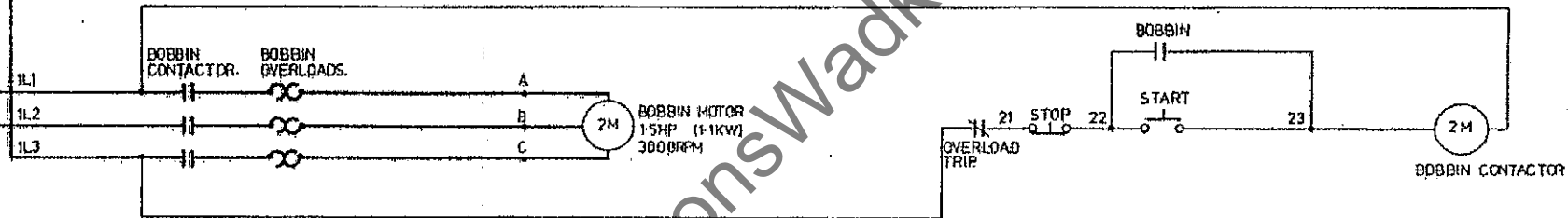
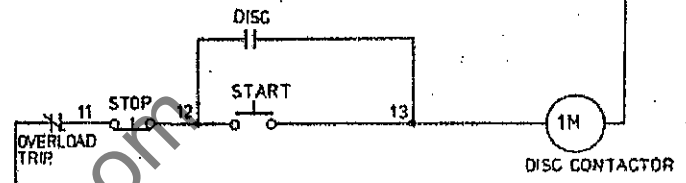
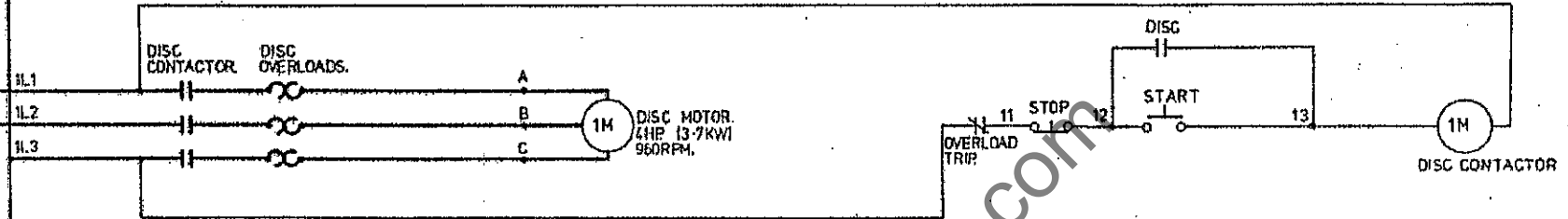
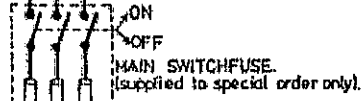

POWER CIRCUIT

CONTROL CIRCUIT

www.DaltonsWadkin.com

SHOW AS TO

SURFACE FINISH	
W	ROUGH M/C
XY	FINISH M/C
YY	ROUGH GRIND
YYY	FINISH GRIND

IMPERIAL UNITS	
FRACTIONS	1 32
DECIMALS	0.005

METRIC UNITS	
DIAMETER	± 0.04mm
DECIMALS	± 0.1mm
WALL THICKNESS UNITS - SEE LIST	

DATE	SG	F	E	D	C	B	A
1.12.76							

THIRD ANGLE PROJECTION WADKIN LTD. LEICESTER

DESCRIPTION	QTY	MATERIAL
JTA SANDER		

PART NO
D.2340



... blow away harmful dust, chips and dirt with a Wadkin Electric Blower

No motor can run at its maximum efficiency with its ventilating duct or control gear covered with dust and dirt. Sooner or later the resultant overheating will cause serious trouble.

Similarly, accumulations of chips and dust in the mechanical parts of the machine can interfere with its efficiency. A few minutes a week for blowing down all Woodworking Machinery will be amply repaid in better and easier running, in increased life, and freedom from breakdown.

Blowers can be supplied for single phase A.C. or Direct Current for any voltage up to 250.

Please state voltage when ordering.





SPARE PARTS BOOKLET

CONTENTS

1. Basic ordering requirements.
2. Sample type order.
3. List of item numbers and description of item.
4. Drawing showing item numbers.

JTA

DISC & BOBBIN SANDER

www.DaltonsWadkin.com

SPARE PARTS

Should spare parts be required due to breakage or wear full particulars including the machine and test number must be given. This information is on the nameplate attached to the machine and will be similar to the picture below.

Wadkin Ltd.
LEICESTER ENGLAND

MACHINE SERIAL NO.	FD 9134	
MACHINE TEST NO.	75601	
PATENT NO.		
VOLTAGE	PHASE	CYCLES
400	3	50

SEE MAINTENANCE INSTRUCTION
BOOK FOR LUBRICATION DETAILS

Please see the next page for sample detail of how to order spare parts.

MACHINE: JTA

MACHINE NO: 1407

TEST NO: 68975

PARTS REQUIRED

1 - JTA107/JTA2 STATOR FRAME
1 - JTA107/JTA13 END COVER FOR END SHIELD
1 - JTA107/JTA50 DISC SHAFT
1 - JTA107/JTA53 HANDWHEEL SHAFT
1 - JTA107/JT80 DRIVING PEG FOR BOBBIN

www.DaltonsWadkin.com

JTA SPARE PARTS LIST

JTA107/JTA1/A	MAIN FRAME
JTA107/JTA2	STATOR FRAME
JTA107/JTA3	END CAP FOR STATOR FRAME (PULLEY END)
JTA107/JTA5	EXHAUST HOOD FOR 30" DISC
JTA107/JTA12	END CAP FOR STATOR FRAME (DISC END)
JTA107/JTA13	END COVER FOR END SHIELD
JTA107/JTA14	BEARING BRACKET FOR ELEVATING SHAFT
JTA107/JTA31	TABLE
JTA107/JTA33	EXHAUST PIPE ADAPTOR
JTA107/JTA50	DISC SHAFT
JTA107/JTA51	STUD FOR PIVOT BEARING.
JTA107/JTA53	HANDWHEEL SHAFT
JTA107/JTA55	SPACING PIECE FOR DISC SHAFT
JTA107/JTA57	POINTER FOR FENCE
JTA107/JTA58	SLEEVE NUT FOR TABLE CANTING
JTA107/JTA62	PIVOT PIN FOR FENCE BASE
JTA107/JT21	NUT FOR TABLE SCREW
JTA107/JT46	BRACKET FOR DISC TABLE
JTA107/JT80	DRIVING PEG FOR BOBBIN
JTA107/JT183	SANDING BOBBIN 3½"
JTA107/JT184	TOP END COVER
JTA107/JT185	BOTTOM END COVER
JTA107/JT189	EXPANDER BOLT
JTA107/JT190	NUT FOR DITTO
JTA107/JT192	WASHER
JTA107/JV4	R.H. DISC FLANGE

JTA107/JV11	END COVER FOR DISC SHAFT
JTA107/JV14	FULCRUM BRACKET FOR TABLE
JTA107/JV18	PIVOT BRACKET FOR TABLE
JTA107/JV26	GUARD FOR DISC (30" DISC)
JTA107/JV31	TABLE
JTA107/JV34	FENCE
JTA107/JV35	FENCE BASE
JTA107/JV56	WIDE STRIP FOR DISC TABLE SLIDE
JTA107/JV57	NARROW STRIP FOR DISC TABLE SLIDE
JTA107/JV58	WEAR STRIP FOR DISC TABLE SLIDE
JTA107/JV59	PIVOT PIN FOR TABLE
JTA107/JV64	SWIVEL PIN FOR TABLE ELEVATING SCREW
JTA107/JV65/A	TABLE ELEVATING SCREW
JTA107/JV67	ADJUSTING SCREW FOR DISC TABLE SLIDE
JTA107/JV68	SANDER DISC
JTA107/JV69	KEY FOR DISC FLANGE
JTA107/JV72	STOP SLEEVE FOR ELEVATING SCREW
JTA107/JV73	STUD FOR TABLE STOP
JTA107/JV81	SLIDE STRIP FOR FENCE
JTA107/JV104	SPECIAL SWING AWAY GUARD L.H.
JTA107/JV106	PIVOT PIN FOR ABOVE GUARD
JTA107/JY3	SPINDLE SLIDE
JTA107/JY4	BEARING END SHIELD FOR SPINDLE SLIDE
JTA107/JY6	WORM GEAR COVER
JTA107/JY8	SPINDLE ADJ. SLIDE
JTA107/JY9	WORM GEAR FOR RECIPROCATING MOTION
JTA107/JY10	PIVOT BRACKET FOR TABLE

JTA107/JY10/A	PIVOT BRACKET FOR TABLE
JTA107/JY14	OIL COVER FOR SPINDLE SLIDE
JTA107/JY15	BLANK END COVER FOR SPINDLE SLIDE
JTA107/JY16	BRACKET FOR TABLE CANTING GEAR BOX
JTA107/JY17	POINTER FOR ANGLE INDICATOR
JTA107/JY18	PIVOT BEARING FOR TABLE CANTING HANDWHEEL
JTA107/JY27	CONN. LINK FOR RECTIPROCATING MOTION
JTA107/JY38	CLIP RING FOR END COVER
JTA107/JY42	SPINDLE
JTA107/JY43	3½" TABLE CENTRE PLATE
JTA107/JY47	DUST BELLOWS FOR SPINDLE
JTA107/JY50	WORM FOR RECIPROCATING MOTION
JTA107/JY51	SLEEVE FOR SPINDLE
JTA107/JY52	SCREW FOR CONN. LINK
JTA107/JY53	SPINDLE FOR WORMWHEEL
JTA107/JY54	BUSH FOR WORMWHEEL
JTA107/JY55	BUSH FOR CONN. LINK
JTA107/JY56	PIVOT PIN FOR CONN. LINK
JTA107/JY57	ELEVATING SCREW FOR ADJUSTING SLIDE
JTA107/JY59	SLIDE STRIP FOR SPINDLE SLIDE
JTA107/JY60	SLIDE STRIP FOR SPINDLE SLIDE
JTA107/JY61	WEAR STRIP FOR SPINDLE SLIDE
JTA107/JY62	C/BALANCE COMPRESSION SPRING
JTA107/JY76	STOP COLLAR
JTA107/JY86	PEG FOR ELEVATING SCREW
JTA107/JY102	COLLAR FOR TOP BEARING
JTA107/JY103	OIL DRAIN PIPE
JTA107/JY194	END COVER
JTA107/JY195	DUST COLLAR FOR TOP BEARING
JTA107/JY197	DUST RING (FOR TABLE)

JTA107/1B	BALL BEARING LOCKNUT
JTA107/3B	HANDWHEEL
JTA107/3F	HANDWHEEL
JTA107/4B	BALL BEARING LOCKNUT
JTA107/4C	BALL BEARING LOCKNUT
JTA107/7D	BALL BEARING LOCKNUT
JTA107/74	GREASE RETAINER
JTA107/81	GREASE RETAINER
JTA107/5	COLLAR
JTA107/SKF1308	SKEFCO BEARING
JTA107/R545	HOFFMANN BEARING
JTA107/SKF. RM9	SKEFCO BEARING
JTA107/SKF. RM11	SKEFCO BEARING
JTA107/EKA75	COLLAR FOR CUTTER SPINDLE
JTA107/EV61	WASHER FOR RAISING SCREW
JTA107/MF105	GREASE RETAINERS FOR CHAIN ROTOR SPINDLE
JTA107/QE3	MITRE WHEEL
JTA107/QV4	OIL GEAR

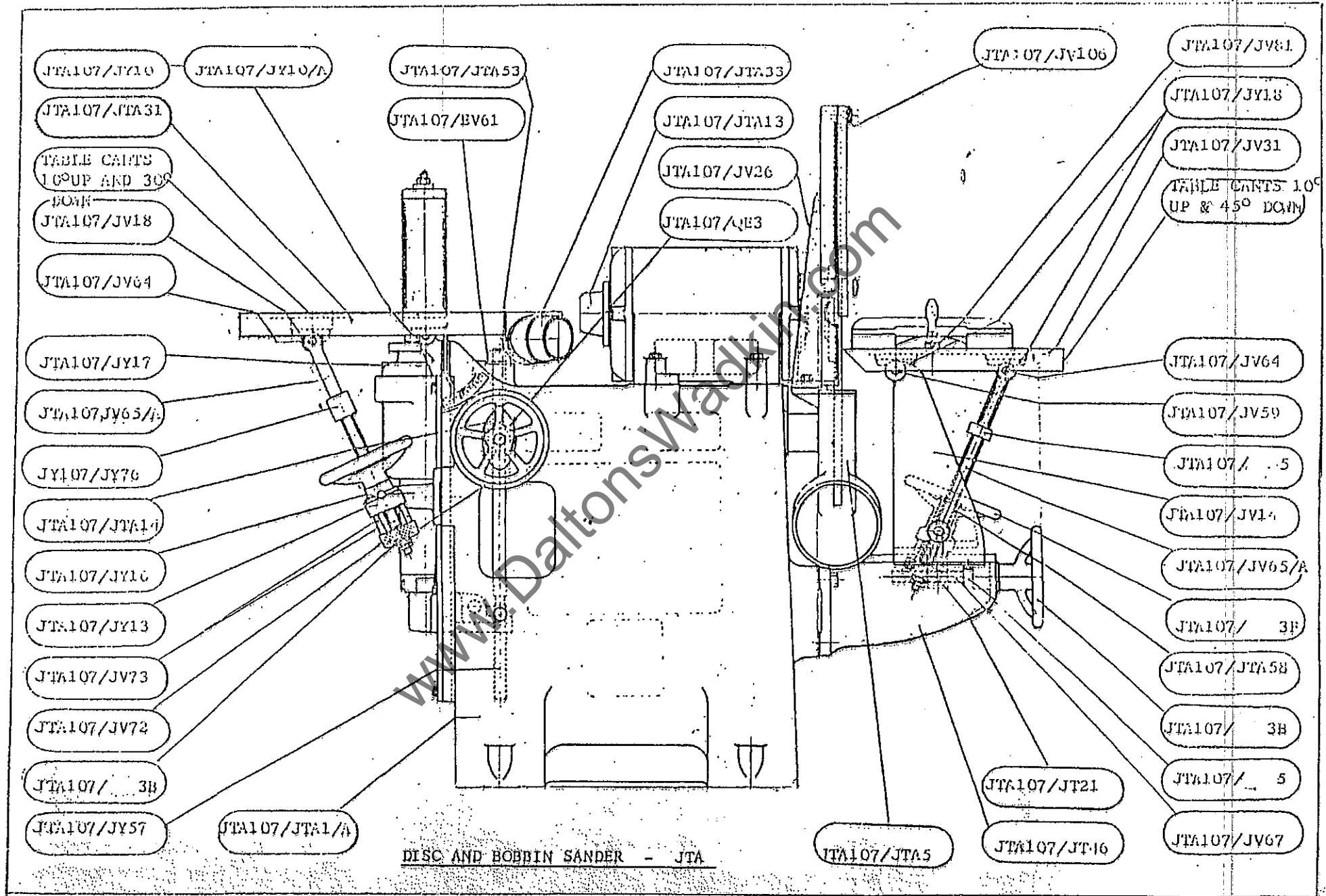

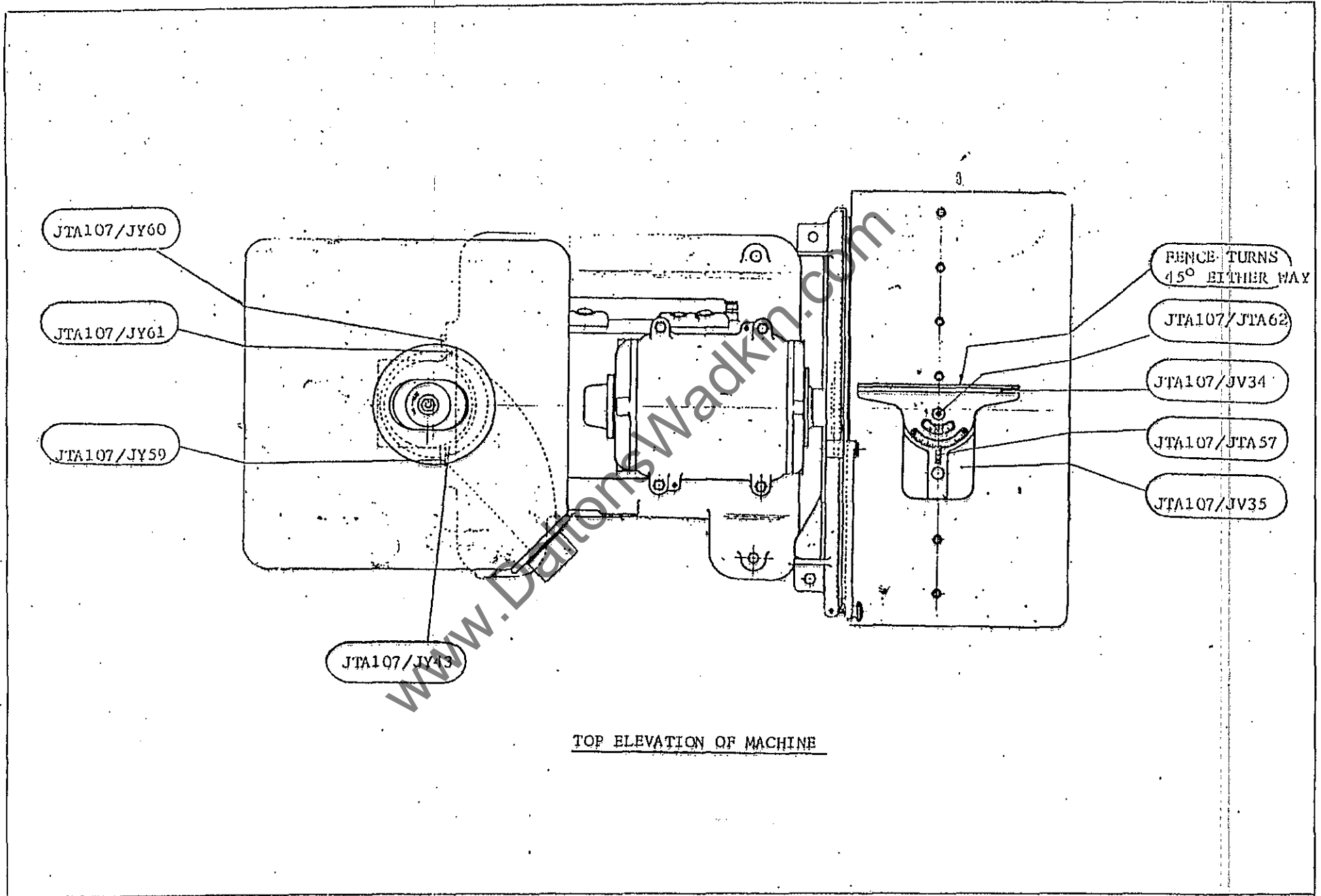

TOP ELEVATION OF MACHINE

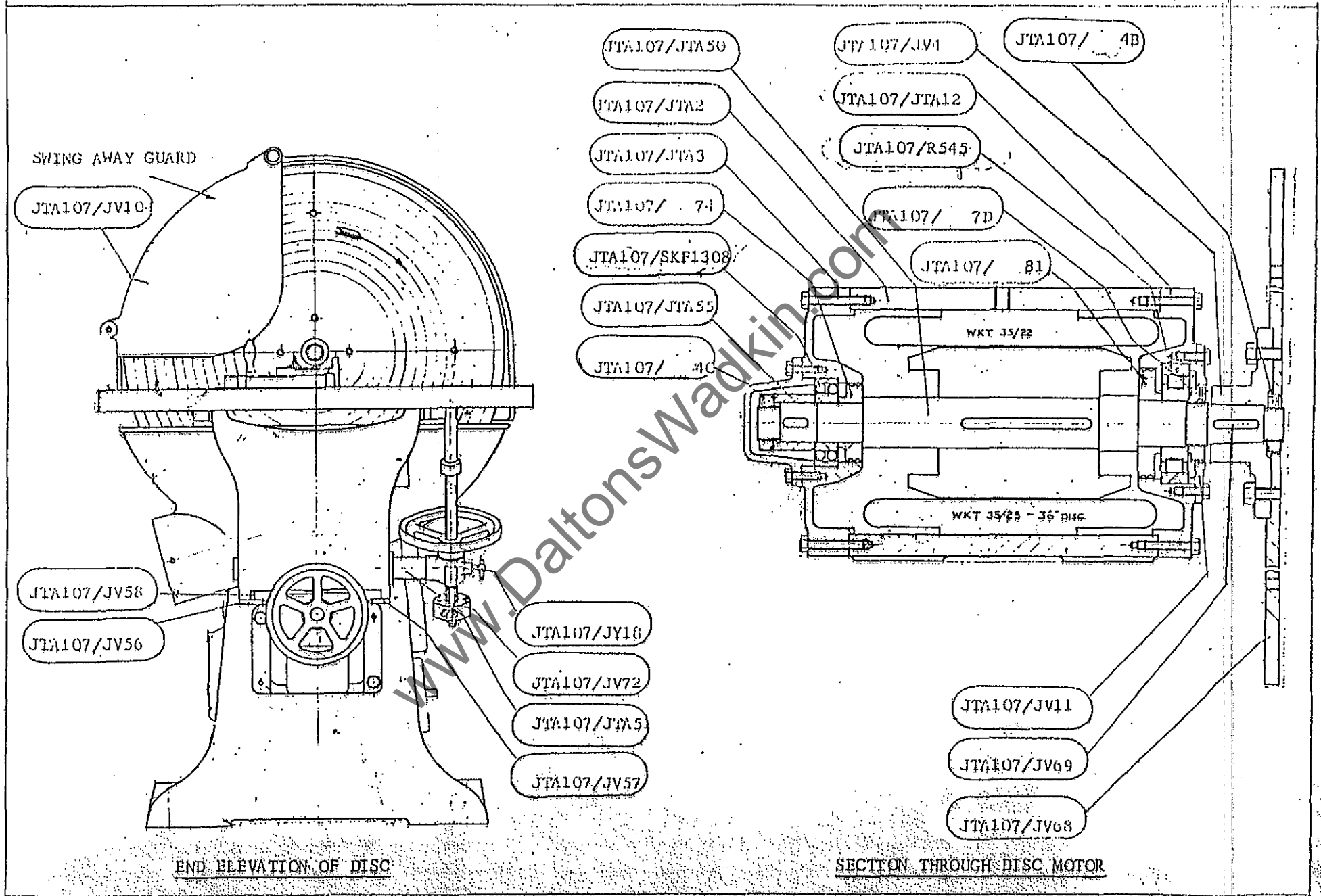

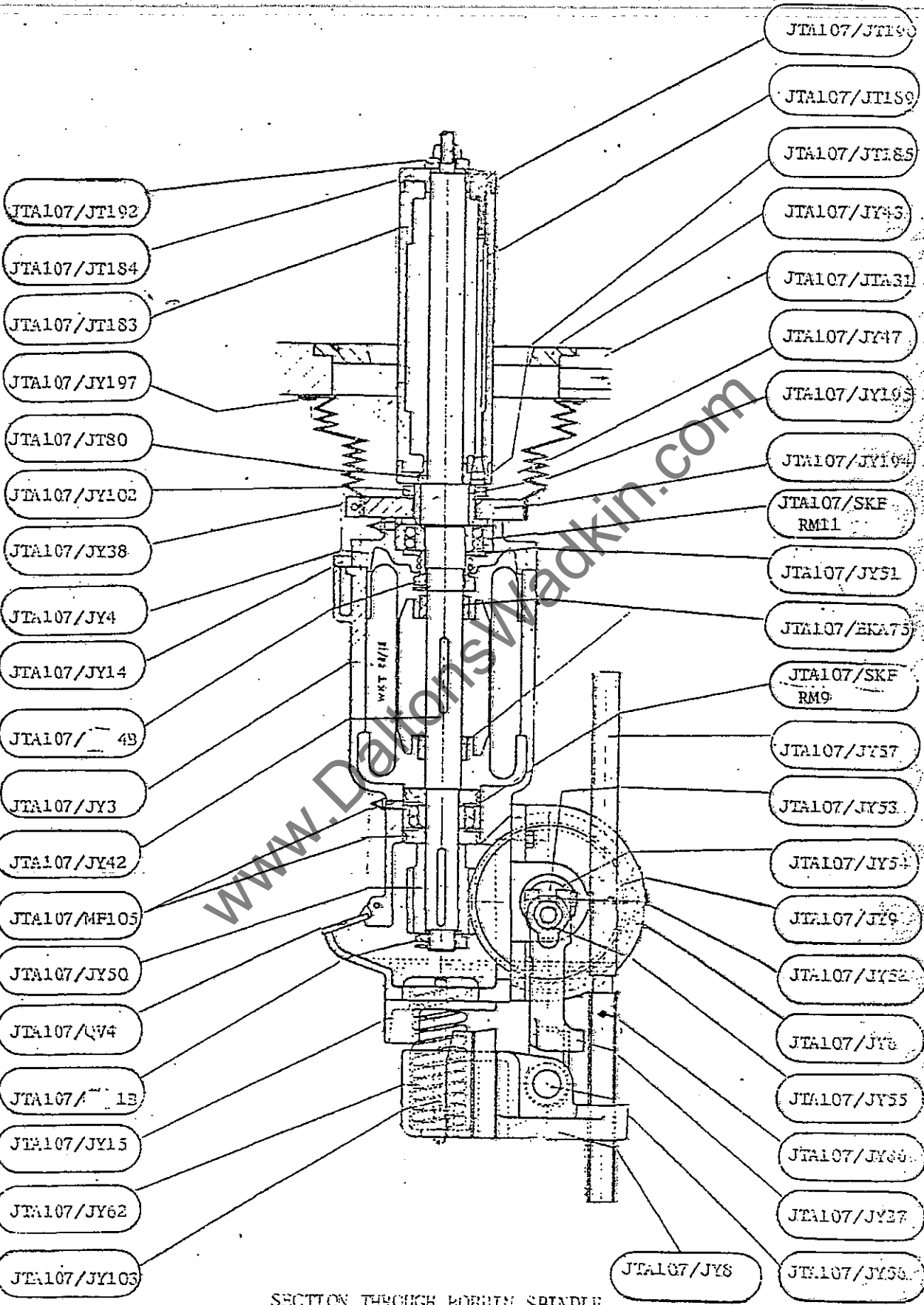

SECTION THROUGH BOBBIN SPINDLE