



**'Wadkin' Through Feed  
Four Side Straightening/  
Planing Machine and Moulder**

**Model GD**

M/C. No.
TEST No.



**MANUFACTURERS E.C. DECLARATION OF CONFORMITY**

The following machine has undergone "Conformity Assessment" and is "self" certificated in accordance with:-

Supply of Machinery (Safety) Regulations 1992  
and Amendment No. 2063

**COMPANY**

WADKIN LTD  
Green Lane Road  
Leicester  
LE5 4PF

**RESPONSIBLE PERSON**

Mr A Lott (Managing Director)

**MACHINE DESCRIPTION**

TYPE THROUGHFEED PLANER MOULDER

MODEL GD 220

**DIRECTIVES COMPLIED WITH**

Supply of Machinery (Safety) Regulations 1992  
Amendment No. 2063 1994  
Draught Proposal CEN/TC 142  
ISO 9001 Part 1

**SIGNED ON BEHALF OF WADKIN LTD**

A handwritten signature in black ink, appearing to be "A. Lott", written over a dotted line.

## IMPORTANT

### SAFETY PROCEDURES AND CONSIDERATIONS

To ensure safe working conditions, persons operating and assisting with the operation of this machine must ensure that they read and fully understand the instructions given within this manual and have received sufficient training in the use of the machine and the safety aspects to be observed.

**Note:-** Persons under the age of 18 years must not operate the machine except during the course of training under the supervision of a trained operator.

#### A) POINTS TO NOTE BEFORE OPERATING OR ASSISTING WITH THE OPERATION OF THE MACHINE.

- 1) You have read and understand the operation and safety aspects of the machine and have been checked out by a qualified supervisor.
- 2) The machine is supplied with full safe guarding. The machine shall not be operated unless the safe guardings are in position and are functional.
- 3) Cutters/blades are the correct type, suitable for the machine and working conditions, rotate in the correct direction of cut, are sharp and correctly fitted.
- 4) Correct spindle and speeds are selected for the cutter equipment and working conditions.
- 5) Loose clothing is either removed or securely fastened back and jewellery removed.
- 6) Adequate working space and lighting is provided.
- 7) All dust extraction equipment is switched on, properly adjusted and working adequately.
- 8) The machine is securely installed (refer to installation section within this manual).
- 9) The machine should only be used for cutting wood or materials with physical and technological characteristics similar to wood, and for which the chip or particle removal process is similar.
- 10) Only use tooling that complies with prEN 847-1. Sawblades made of High Speed Steel (HSS) MUST NOT be used.



**B) DURING MACHINING:-**

- 1) Wear suitable protective clothing e.g, approved eye protection, ear defenders and dust masks. Gloves shall be worn when handling tooling.
- 2) Stop the machine using the emergency stop or at the mains isolator before making adjustments, cleaning or carrying out maintenance.
- 3) Keep the floor area around the machine clean and free from wood refuse. Do not allow the floor around the machine to become slippery.
- 4) Stop the machine and report immediately to a person in authority any actual or potential malfunction or operator hazard. Do not attempt to repair or rectify the machine unless qualified or authorised to do so.
- 5) The operator must not leave the machine running whilst unattended.
- 6) Never by-pass interlocks.

**WARNING:-**

Failure to observe correct operating procedures prior to and during operation of this machine can result in severe injury.

**DO NOT** attempt to operate the machine while under the influence of anything that reduces your alertness.



## PREFACE

### IMPORTANT

IT IS OUR POLICY AND THAT OF OUR SUPPLIERS TO CONSTANTLY REVIEW THE DESIGN AND CAPACITY OF OUR PRODUCTS. WITH THIS IN MIND WE WOULD REMIND OUR CUSTOMERS THAT WHILE THE DIMENSIONS AND PERFORMANCE DATA CONTAINED HEREIN ARE CURRENT AT THE TIME OF GOING TO PRESS, IT IS POSSIBLE THAT DUE TO THE INCORPORATION OF THE LATEST DEVELOPMENTS TO ENHANCE PERFORMANCE, DIMENSIONS AND SUPPLIERS MAY VARY FROM THOSE ILLUSTRATED

#### **Wadkin Leicester**

Green Lane Works, Leicester LE5 4PF, England.  
Telephone: 0533 769111 Telex: 34646 Wadkin G.  
Fax: 0533 742310



INSTRUCTION MANUAL

WADKIN

THROUGH FEED FOUR SIDE  
STRAIGHTENING/PLANING MACHINE  
AND MOULDER

MODEL GD

PREFACE

Health and Safety  
Safeguarding machines

[www.DaltonsWadkin.com](http://www.DaltonsWadkin.com)

## HEALTH AND SAFETY

This machine is designed and constructed using the principles of safeguarding and practical guidance contained in the British Standard Codes of Practice BS5304: 1988 "Safeguard of machinery", BS6854: 1987 "Safeguard woodworking machines" and current guidance issued by the Health and Safety Executive.

The Health & Safety at Work etc Act 1974 places duties in designers, manufacturers and suppliers to ensure that:-

- (1) Articles supplied for use at work are, so far as is reasonably practicable, safe and without risks to health during setting, use, cleaning and maintenance.
- (2) Persons supplied with the articles are provided with adequate information about the use for which they are designed, and about conditions necessary to ensure that they will be safe and without risks to health.

These duties are transferred to you if you re-supply the machine by way of sale, lease, hire or hire-purchase.

Persons who install this machine for use at work have a duty under the Health and Safety at Work etc Act 1974, to ensure so far as is reasonably practicable, that nothing about the way in which it is installed makes it unsafe or a risk to health. This includes such aspects as correct assembly, electrical installation, construction of enclosures, fitting of guards and exhaust ventilation equipment. When installing the machine, consideration must be given to the provision of adequate lighting and working space.

The legal duties of designers, manufacturers, importers, suppliers, erectors and installers are explained in the free Health and Safety Executive leaflet IND(G) 1(L) 1987.

The machine is supplied complete with all necessary safeguards to enable the user to comply with the Woodworking Machines Regulations 1974. Details of correct installation and use, together with guidance on fitting and proper adjustment of guards are described in Sections 1 to 4 of this manual.

You are reminded that the Woodworking Machines Regulations place absolute legal duties on employers and employees to ensure that guards and any other safety devices are securely fitted, correctly adjusted and properly maintained.

Repairs and maintenance must only be undertaken by suitably qualified and competent technicians. Ensure that all power supplies are isolated before any maintenance work commences. Instructions for routine maintenance are given in Section 4 of this manual.

Machine operators must have received sufficient training and instruction as to the dangers arising in connection with the machine, the precautions to be observed and the requirements of the Woodworking Machines Regulations which apply, except where they work under the adequate supervision of a person who has a thorough knowledge and experience of the machine and the required safeguards.

Persons under the age of 18 years must successfully complete an approved course of training before operating this machine at work, unless participating in a course of training under adequate supervision. (N.B. This paragraph is only relevant to; circular sawing machines, any sawing machine fitted with a circular blade, any planing machine for surfacing which is not mechanically fed or any vertical spindle moulding machine.)

Before commencing work, ensure that the cutters/blades are, set to cut in the correct direction, securely fitted, sharp, and are compatible with the machine and spindle speed.

### Dust

Wood dust can be harmful to health by inhalation and skin contact and concentrations of small dust particles in the air can form an explosive mixture. These concentrations usually occur in dust extraction equipment which may be destroyed unless explosion precautions have been taken in the design and installation of the equipment.



Employees have duties under the Factories Act 1961 and the Health and Safety at Work etc Act 1974 to control wood dust in the workplace and from 1st October 1989 more specific requirements will be imposed by the Control of Substances Hazardous to Health Regulations 1988.

Employers should carry out an adequate assessment of the possible risks to health associated with wood dust to enable a valid decision to be made about the measures necessary to control the dust. It may be necessary to provide effective exhaust appliances.

Prevention or control of wood dust exposure should, so far as is reasonably practicable, be achieved by measures OTHER than the provision of personal protective equipment.

Airborne dust levels should not exceed 5 mg/cub.m

Further information and reference to practical guidance are contained in the following free leaflets available from the Health and Safety Executive:-

Wood Dust:	IND(S) 10(L) 1987
Hazards and Precautions	
Control Hardwood Dust	IND(S) 21(L) 1988

## Noise

Noise levels can vary widely from machine to machine depending on conditions of use. Persons exposed to high noise levels, even for a short time, may experience temporary partial hearing loss and continuous exposure to high levels can result in permanent hearing damage. The Woodworking Machines Regulations require employers to take reasonably practicable measures to reduce noise levels where any person is likely to be exposed to a continuous equivalent noise level of 90 dB(A) or more, over an 8 hour working day. Additionally, suitable ear protectors must be provided, maintained and worn.

An adequate assessment of likely noise exposure should be made using manufacturer's data and if necessary, a noise survey should be carried out by a competent person. It may be necessary to construct a suitable noise enclosure, in which case professional advice should be sought.

Machines identified as generating unhealthy noise levels should be appropriately marked with a warning of the need to wear hearing protection and it may be necessary to designate particular areas of the workplace as "Ear protection zones". Suitable warning signs are specified in the Safety Signs Regulations 1980.

Further information and reference are contained in the free Health and Safety Executive leaflet - Noise at Woodworking Machines IND(S) 22(L) 1988.



## SAFEGUARDING MACHINES

To comply with the Woodworking Machines Regulations 1974, operators must ensure that they fully understand the instructions given and have received sufficient training in the use of the machine and the particular safety instructions to be observed.

**NOTE:** Persons under the age of 18 years **must not** operate the machine except under supervision during a course of training.

### BEFORE OPERATING THE MACHINE ENSURE THAT:

All guards and fences are securely fitted and correctly adjusted in accordance with the Regulations.  
Cutters/blades are the correct type and rotate in correct direction of cut, are sharp and securely fastened.

Cutter equipment is suitable for machine spindle speed.

Loose clothing is either removed or fastened and jewellery removed.

Sufficient working space is provided and that lighting is adequate.

All dust extraction equipment is switched on, properly adjusted and working efficiently.

### DURING MACHINING:

Wear suitable protective equipment, e.g. goggles, ear defenders, and dust mask.

Stop the machine before making adjustments or cleaning chips from the work area.

Keep the floor area around the machine clean and free from wood refuse.

Do not allow the floor to become slippery with oil or grease.

Report immediately to a person in authority, any machine malfunction or operator hazard. Do not attempt to repair the machine unless qualified to do so.

Ensure all power sources are isolated before commencing any maintenance work.

**WARNING:** Failure to comply with the Regulations is a criminal offence and could result in legal proceedings.



**SECTION 1            OPERATING PRACTICE**

- General Description
- Leading Particulars
- Common Operating Problems

**SECTION 2            INSTALLATION**

- Lifting and Transportation
- Installation Data

**SECTION 3            OPERATING INSTRUCTIONS**

- General Information
- Mounting the Cutterblocks
- Setting up the Machine
- Faults in the Workpieces and their Causes
- Cleaning the Machine
- Dial-a-Size Electronic Positioning

**SECTION 4            MAINTENANCE**

- Scheduled Maintenance
- Unscheduled Maintenance
- Fault Finding
- Motor Drive Belt Data

**SECTION 5            ILLUSTRATED PARTS LIST**

## SECTION 1

### OPERATING PRACTICE

	Content	Page
1:1	<b>General Description</b>	
	General notes	1-1
	Machine feed systems	1-2
	Noise	1-5
1:2	<b>Leading Particulars</b>	
	Principal dimensions and capacities	1-7
1:3	<b>Common Operating Problems</b>	
	Timber stops in machine	1-9
	Ripples appear on surface of workpiece.	1-9
	Bumps on infeed or outfeed end of workpiece.	1-9
	Machine will not straighten timber.	1-10
	Timber runs away from fences.	1-10
	Tooling	

## LIST OF ILLUSTRATIONS

	DESCRIPTION	PAGE
1:1	FIG 1 SURFACE RIDGES ON TIMBER	1-1
	FIG 2 CUTTERBLOCK CLEARANCE ON SPINDLE	1-1
	FIG 3 HYDROFIX LOCKING ON SPINDLE	1-1
	FIG 4 JOINTING OF CUTTERBLOCK	1-2
	FIG 5 EFFECT OF REPEATED JOINTING ON KNIVES	1-2
	FIG 6 PUSH FEED ARRANGEMENT	1-2
	FIG 7 THROUGH FEED ARRANGEMENT	1-3
	FIG 8 STRAIGHTENING ON LONG INFEEED TABLE	1-3
	FIG 9 ALTERNATIVE STRAIGHTENING	1-3
	FIG 10 GROOVED BED STRAIGHTENING	1-3
	FIG 11 HOPPER FEEDING	1-3
	FIG 12 FAST FEED TABLE	1-4
	FIG 13 SPLITTING	1-4
	FIR 14 DIAL-A-SIZE POSITIONING	1-4
	FIG 15 RANDOM WIDTH MACHINING	1-4
1:3	FIG 1 GENERAL VIEW OF MACHINE	1-9

## 1:1 GENERAL DESCRIPTION

### General Notes on Wadkin Planing and Moulding Machines

A planing and moulding machine produces planed or moulded surfaces on all four sides of lengths of timber, both hard and softwood, at feed speeds determined by the cutter equipment and quality of surface finish required.

A series of 'ridges' (cutter marks) is created on the surface of the timber as it is moved past a rotating cutterblock (see Fig 1). The quality of surface finish is determined by the number of knife marks per 25mm (1") (the pitch of the cutter marks). The closer the pitch the better the quality of surface finish.

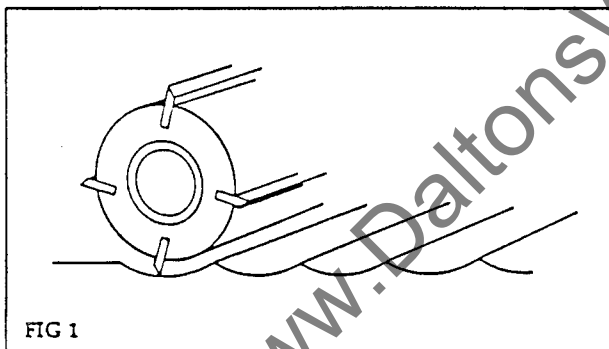

FIG 1

From experience a good quality surface finish has knife marks at a pitch of 1.5 to 2 mm. Reducing the pitch improves the surface finish but increases the wear on the cutters, increasing the pitch reduces the quality.

The number of cutter knives in a cutterblock will only be effective when all are rotating in precisely the same cutting circle. Two main factors influence this:

- a. The fit of the cutterblock on the spindle
- b. The concentricity of grinding.

The conventional method of mounting a cutterblock is to lock a plain bore block on to a plain ground spindle with a locknut. The tolerances in each component give a possible 0.05mm (0.002") clearance in the bore and thus eccentric running (see Fig 2).

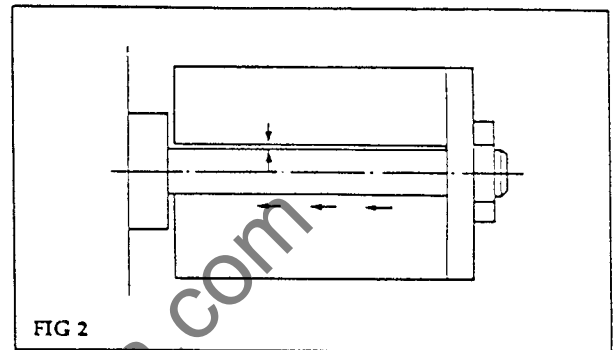

FIG 2

The Wadkin Hydrofix locking system eliminates this clearance by pressurising the bore of the cutterblock onto the spindle (see Fig 3).

Axial locking is not required and a simple safety collar is recommended to prevent the cutterblock moving axially, or rotating on the spindle, if the hydraulic pressure is not applied.

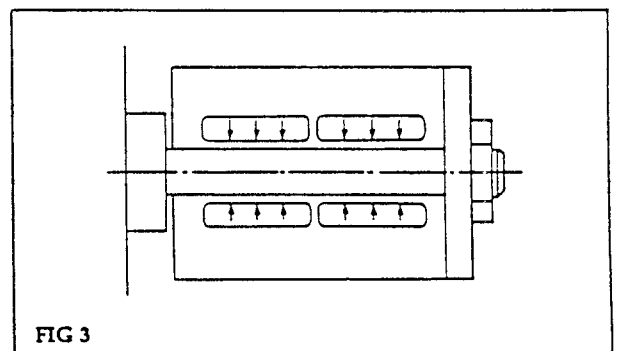

FIG 3

Because the Hydrofix locking is also used while the knives in the cutterblock are ground in the toolroom, it can be seen that the high accuracy of the grinding process is transferred directly to the planing and moulding machine. This accuracy, together with the true running of the precision spindle of the moulder, reduces the running of the knives to within 0.002 to 0.005mm of the true cutting circle. However, this minimum run-out is still such that only one knife leaves a finishing cut, no matter how many are in the block.

To ensure that all the knives in a cutterblock run in an absolutely true cutting circle, the technique of jointing is used, in which the jointing 'stone' trues all the knives while rotating at cutting speed in the planing and moulding machine (see Fig 4).

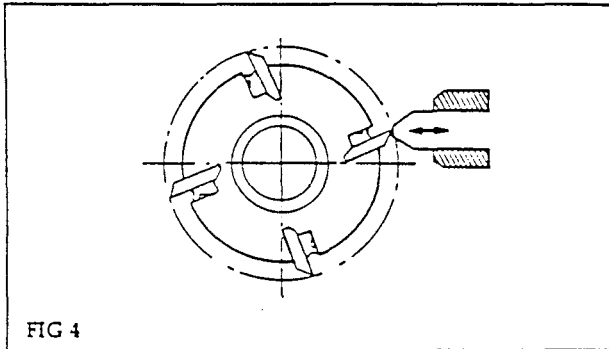

FIG 4

It can be seen that for a given spindle speed and quality of surface finish (pitch of knife marks), the feed speed may be increased in direct relationship to the number of knives in the cutterblock.

$$\text{Cuttermark pitch} = \frac{\text{Feedspeed in mm per min}}{\text{Block rpm} \times \text{No of Cutters}}$$

$$\text{For example } \frac{12 \times 1000}{6000 \times 1} = 2\text{m pitch}$$

for a spindle running at 6000 rpm and a feed speed of 12m/min and unjointed (1 knife finishing)

Jointing a 4 knife block and increasing the feed speed to (4×12) ie: 48m/min gives the same resulting pitch (finish).

Jointing can be carried out on straight planing blocks — 'straight' jointing, and on profile blocks — 'plunge' jointing.

The process of jointing, which can be repeated several times, produces a heel on the knives. In the interests of quality this must not be allowed to exceed a certain width. This is approx 0.5mm on softwood and 0.7mm on hardwood (see Fig 5).

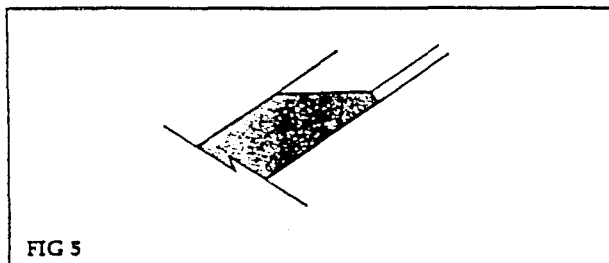

FIG 5

Both high speed steel and carbide knives may be jointed but require a different composition of jointing stone.

An alternative method of increasing output is to increase the spindle speed thus permitting a faster feed speed for a given quality of surface finish. 'Wadkin' can offer alternative spindle speeds up to a maximum of 15000 rpm. This highest spindle speed, achieved with very high precision, lubricated for life bearings, permits a 2½ × (250%) increase in output without jointing.

Typical surface finish pitch values for different applications are listed:

Sawmilling	1.5 to 2.5 mm
Joinery	1.5 to 2 mm
Strip moulding	1.3 to 2.0 mm
Furniture	1 to 1.5 mm

### Machine Feed Systems

#### Push Feed (Fig 6)

This original method of feeding a planing and moulding machine is still provided, and consists of two top driven and two opposed bottom driven feed rolls at the infeed end of the machine. An idle roller and pad pressures between the cutterheads controls the timber down to the bed and across to the fence as it passes through the machine. It follows that if bowed or twisted stock is fed to the cutters, that while a perfect profile will be produced, the component will be as twisted or bowed as it entered.

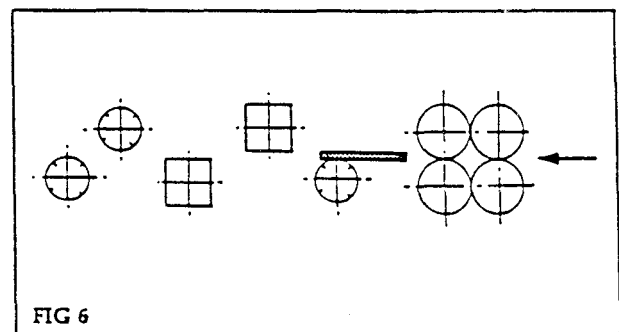

FIG 6

The pushfeed machine has the disadvantage that the last piece of timber is always left in the machine; traction stops as the trailing end leaves the feedworks. The last piece can only be retrieved by following with a scrap length or by reverse feeding, in which case the component is unfinished.

*Through feed (Fig. 7)*

Through feed was developed to overcome the handicap of the last piece remaining in cut, and to eliminate the heavy top and side pressures.

Drive rolls between each cutterhead feed the components through the machine.

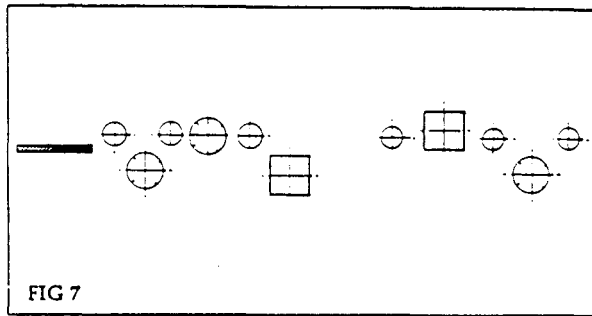

FIG 7

A long infeed table before the first bottom head, together with the much lighter loading on the timber, enables straightening of the component ie: the underside being straightened (surfaced) at the first bottom head, and the edge (fence side) being straightened at the first side head (see Fig 8).

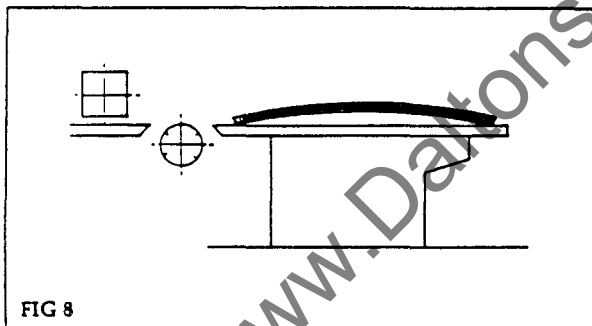

FIG 8

An alternative method of straightening combines underside and fence side straightening, using a single cutterblock, planing the underside in the normal way and machining a reference edge with a rebating disc on the same block (see Fig 9).

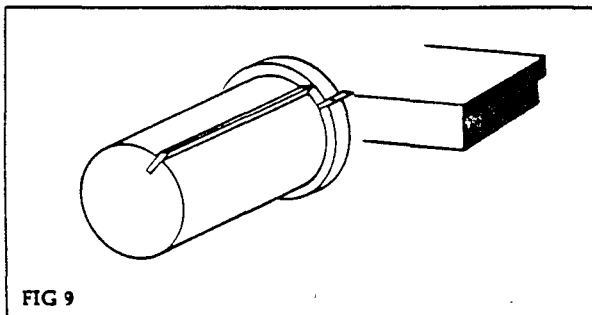

FIG 9

The above straightening techniques are most successful on timber which is bowed and has square ends, typical of softwood. For timber which is twisted and has out-of-square ends, typical of some hardwoods, an alternative technique is provided.

*Grooved bed straightening (Fig 10)*

In this design, grooving cutters on the first bottom head permit support in the form of rails right through the cut, thus preventing 'dipping in' of the twisted timber, or 'buckling' as out-of-square ends come into contact with each other. The grooves on the underside are subsequently machined out on a second bottom head, which is obligatory. Fitting a standard lip plate and cutterblock converts the machine to conventional use.

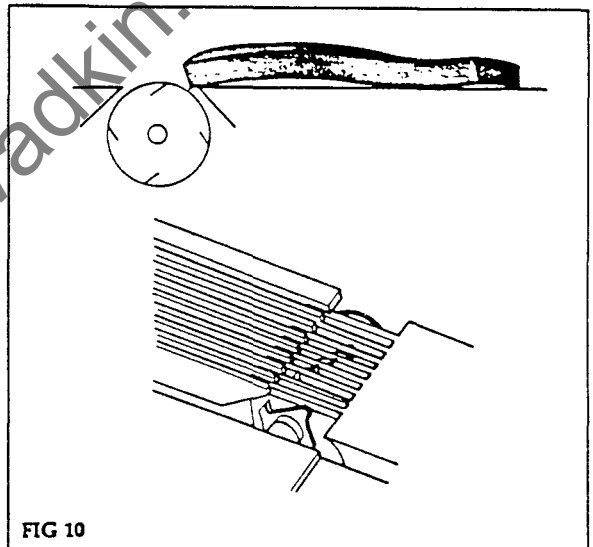

FIG 10

*Hopper Feeding (Fig 11)*

To enable the operator to feed timber at relatively fast feed speeds and still maintain butt up, (this may be difficult on short lengths), various types of hopper feed are available.

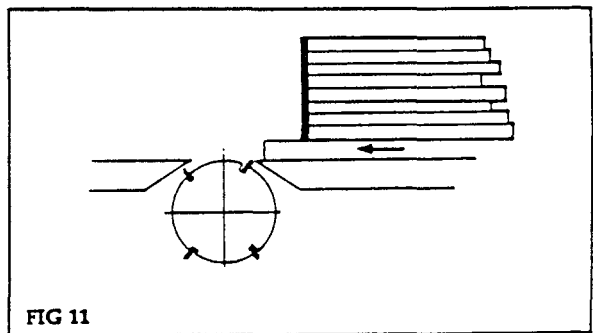

FIG 11

Components are stacked in a hopper at the infeed end of the machine and automatically fed one at a time from the bottom of the stack at a rate to ensure 'butt-up'. A slipping device prevents the hopper feed trying to overdrive the machine feed.

Feeding at very high feed speeds, typically on flooring, cladding etc, also presents problems to the operator, again a special feeding device. (Fast feed table, Fig 12) can be provided.

The fast feed table, in line with the machine feed, receives timber from a tilt hoist and cross chains, the driven rollers in the fast feed table and an overhead hydraulically driven nip roll ensure butt up before entry into the machine feedworks, a slipping arrangement prevents overdriving.

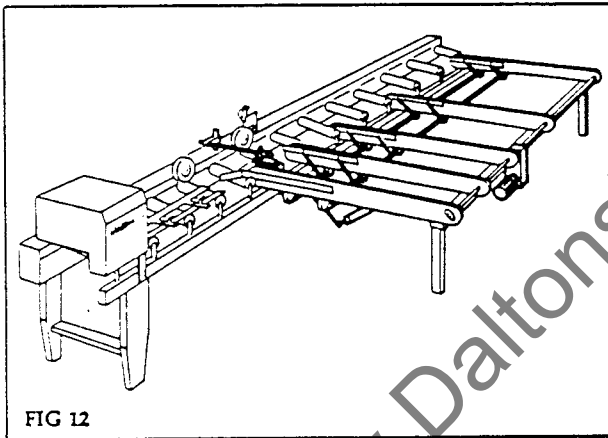

FIG 12

#### Outfeed Equipment

Generally used on high feed speed machines, this equipment can be provided at the outfeed end of 'Wadkin' moulders to transfer to another process, ie: stack, bundle, wrap, count, etc. Outfeed equipment can be provided and programmed to print on each component some identifying information. eg. Job No. Date, etc. Combinations of these facilities enable the finished components to be presented in a variety of ways at the outfeed end of the machine.

#### Extra Head Positions

Typically a planing and moulding machine has four heads to machine all four faces, these can be augmented with the addition of other heads. The most common is a second bottom head to ensure clean up on the underside. Where the amount of timber to be removed is great, or where the mould detail is complex, it

may be necessary to provide extra top side or bottom heads. These are available on both push and through feed machines.

#### Splitting (Fig 13)

Splitting is a common operation, usually done on the last bottom head, and often requiring very large horse powers. Such a head is available and may be fitted with anti kick-back fingers to prevent ejection towards the operator.

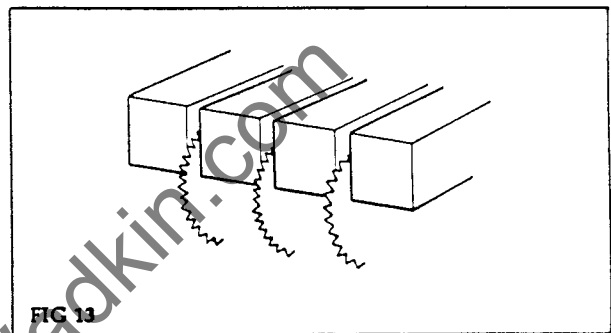

FIG 13

#### Universal Head

A universal head, either three or four position (always last head on the machine) can be provided to order, or the machine prepared to fit the head at a later date. The three position head may be used as a top head, bottom head or near side head and at any angular position in between. The four position head has the added capability of use as a fence side head.

The universal head gives greater flexibility for splitting and moulding on a conventional machine, and special pressures, chipbreakers, etc. can be provided to ensure perfect control of the workpiece.

#### Dial-a-Size Positioning (Fig 14)

On machines which are used for a large variety of small quantity batches of square dressed

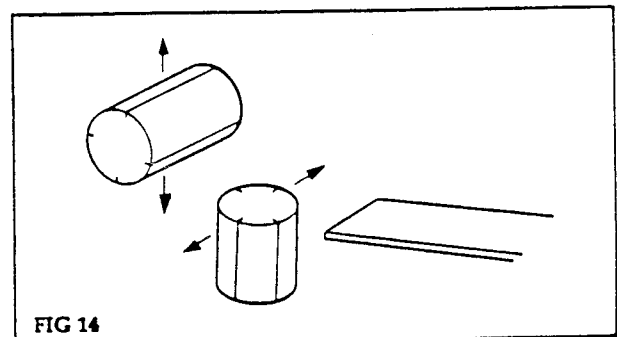

FIG 14



material, the set up time can be reduced by fitting Dial-a-size positioning (see Fig 17 in Operating Instructions).

The near side head horizontal adjustment is motorised and fitted with an encoder, the motorised vertical movement of the top head and feed is also fitted with an encoder.

A programmable memory stores the widths and thicknesses of the workpieces to be produced, and on command the two heads are repositioned to the preset dimensions. In a similar manner, where components of random width are machined (eg. Table tops, see Fig 15). The machine can be arranged to sense the width of the incoming pieces and automatically move the outside head to the required position.

Whilst being a slow operation, (butt feeding is not possible and the feed speed is slow), the facility does have great advantage to some users.

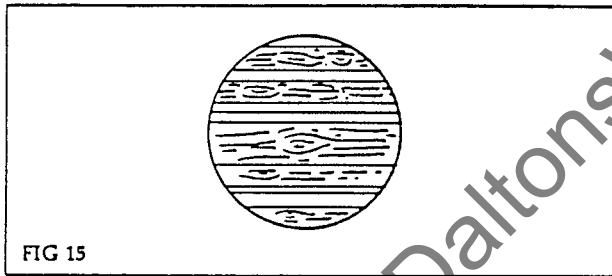

*Feed Enhancement*

The 'Wadkin' push feed and through feed systems are the result of years of experience in the planing and moulding industry, and for the great majority of work are exemplary. However, the great variety of timbers available, and the different conditions in which they are presented to the machine is acknowledged in the various options available to enhance feeding and minimise bed wear.

*Bed Lubrication*

A lubricant is introduced to the surface of the machine bed, from a manual or auto pump; this reduces friction, improves feeding capability and reduces bed wear.

An alternative; of introducing air between the timber and the bed of the machine, can be provided for those machines that do not have a second bottom head to machine off the small amount of oil introduced to the underside of

the timber, or where the material being machined must not in any circumstances be contaminated with oil.

A hard chrome plated bed is also available. This is usually used on high feed speed machines or where particularly abrasive timber is being machined. The reduction in bed wear is very considerable, and feeding is improved because of the low coefficient of friction of chrome plating.

The top driven feed rolls of a through feed moulder are normally spring loaded down onto the workpiece. The required amount of load can vary with the nature of the work being run, although as a general rule it must be as light as practicable, and variation in rough timber thickness will of course increase the load as the feed rolls yield more. Adjustment of the loading is done at each individual roll.

Pneumatic loading can be provided; this has a number of advantages. The loading does not vary with any variation in lift, and the amount of loading can be changed more easily.

One regulator controls the loading to rolls before the top head, and the other regulator controls the rolls after the top head.

**Noise**



Planing and moulding machines, by virtue of the number of cutter heads and the speed of the heads, produce high noise levels, typically between 95dB and 115dB when cutting.

The woodworking machine regulations require that an operator is not to be subjected to noise levels above 90 dBA for 8 hours, some precautions are therefore required.

The manufacturers can supply (or give information about suppliers) a suitable sound enclosure. It is also possible with materials generally available in a sawmill, to make an enclosure on site. It should be noted however that even with a sound enclosure, under some circumstances, because of 'break out' (at say the infeed end), the noise level at the operating positions will be above 90 dBA.

For personal safety reasons the operator should wear ear defenders.

See **WARNINGS** in Operating Instructions before operating the machine.

## 1.2 LEADING PARTICULARS

### Principal dimensions and Capacities

Maximum size of timber admitted	230mm x 130mm
Maximum size of finished work	220mm x 120mm thick
Minimum size of finished work	15mm x 6mm thick
Feed speed (infinitely variable)	6.0 to 22 metres per min
Pressure adjustment of feed rolls	6 bar - reduced (when fitted)
Limit switch at the extremities of the rise and fall beam	
Feed rolls:- shaft mounted infeed	2 x 140mm diameter, serrated steel, 50mm wide
flange mounted near side head	2 x 140mm diameter, serrated steel, 20mm wide
	1 x 140mm diameter, serrated steel, 10mm wide
	1 x 40mm wide spacer
	3 x 20mm wide spacer
shaft mounted after top head	2 x 140mm diameter, polyurethane, 50mm wide
Diameter of cutting spindles	40mm
Speed of cutter spindles	6000 rpm
Diameter of cutting circles	Minimum 100mm all heads Planing: Max 125mm all heads Moulding: Max 195mm all heads
Maximum straightening	10mm
Maximum cut of first bottom head	10mm
Maximum cut of fence side head	10mm
Length of infeed straightening table	2 metres (standard) 2.5 metres - option
<b>Output of Motors</b>	
Feed motor	2.2kW (3hp)
Rise and fall motor	0.37kW (0.5hp)
Spindle motors GD4 and GD4 + 1	
First bottom head	5.5kW (7.5hp)
Fence side head	5.5kW (7.5hp)
Near side head	5.5kW (7.5hp)
Top head	7.5kW (10hp) 11kW (15hp) - option
Second bottom head (if fitted)	5.5kW (7.5hp)

### 1: 3 COMMON OPERATING PROBLEMS

When resolving problems, always work in a systematic logical sequence. Work from the infeed end of the machine through to the outfeed end, checking for faults in a progressive manner.

In this way faults will not be overlooked and remedial action can be taken where needed.

Set (spring loaded) top/side pad pressures with minimum amount of lift. Set side guides (not spring loaded) just up to timber ie: not clear, not trapping. When feeding wide pieces, on a through feed machine it is normally better to space feed rollers than have a solid bank, (see *Setting up the Machine*).

**FAULT Timber stops in machine**

**Check**

Setting of cutterblocks to table and fences.  
Amount of pressure applied to feedrolls (pneumatic or spring).  
Sharpness of cutters.  
Yield of chipbreakers and pad pressures.  
Tightness of side guides onto timber.  
Oil level of bed lubrication pump (if fitted).  
Position of feedrolls on workpiece.

**FAULT Ripples appear on surface of workpiece**

**Check**

Setting of cutterblocks to table or fences.  
Pressure is applied to feedrolls (pneumatic or spring)  
Sharpness of cutters.  
Chipbreakers are set correctly and have sufficient pressure to control timber.  
All locks are applied.  
All pressure pads are in contact with timber.  
Spindle speed (if two speed spindle fitted)  
Tooling is suitable for the work.

**FAULT Bumps on infeed or outfeed end of workpieces**

**Check**

Setting of cutterblocks to table and fences.  
Sharpness of cutters.  
Chipbreakers are set correctly and have sufficient pressure to control timber.  
All locks are applied.  
All pressure pads are in contact with timber.  
Position of side and top pressure rollers.  
Bed and fences for build up of resin or chips.

**FAULT Machine will not straighten timber****Check**

Setting of cutterblocks to table and fences (accurate setting of knife edge to table/fence is critical to obtain perfect straightening).

Sharpness of cutters.

Feed rollers and top/side pressures should not be used before the first bottom head.

Is the amount of cut set at the infeed fence and table adequate for the amount of bow in the timber?

Is the timber to be straightened a stable section?

Is the workpiece within the length of the straightening table and fence?

**FAULT Timber runs away from fence****Check**

Position of side pressure roller before first bottom head (if fitted, and section being worked does not require straightening).

Near side head chipbreaker is in contact with timber.

Top idle roller pressures at side heads are parallel to fence.

Side guides after fence sidehead are adjusted correctly.

Mating faces of feed rolls and spacers are clean.

**Tooling**

When practicable and heads are available, rough out on one head and finish on another, or take part of a mould out on one head and part on another.

Sharp tools produce good quality work, therefore change blocks and sharpen knives at regular intervals to obtain best performance. The cutterblocks supplied with the machine are fitted with high speed steel cutter knives, unless otherwise specified. The cutter spindles should not be run at speeds above that indicated.

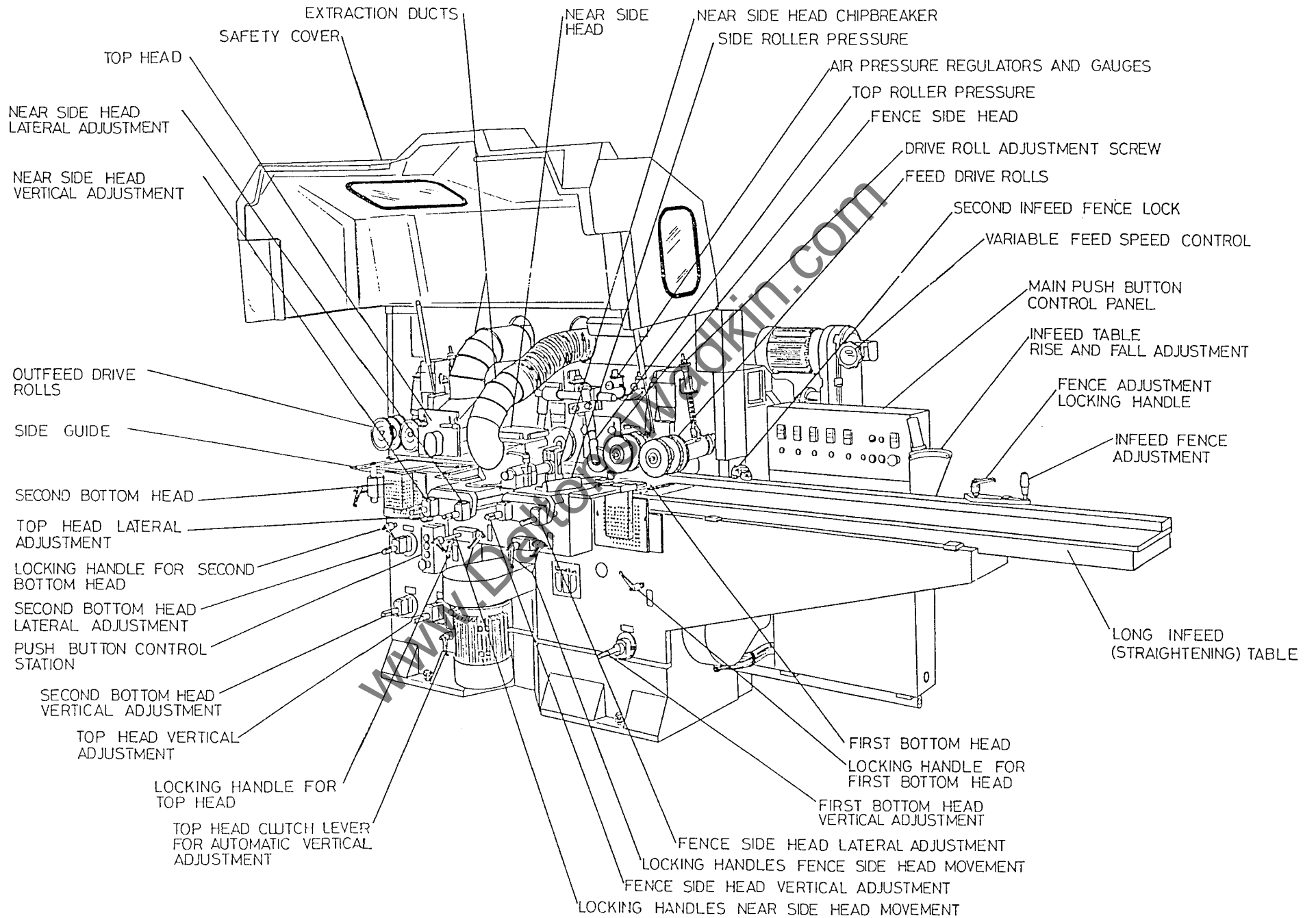

FIG 1 MACHINE CONTROLS AND ADJUSTMENTS

## SECTION 2

# INSTALLATION

	<b>Content</b>	<b>Page</b>
2:1	<b>Lifting and Transportation</b>	
	Unloading	2-1
	Moving	2-1
	Unpacking	2-1
	Cleaning	2-1
2:2	<b>Installation Data</b>	
	Major dimensions and weight	2-3
	Location and foundations	2-3
	Supplies and services	2-3
	<b>LIST OF ILLUSTRATIONS</b>	
2:1	Fig 1 Lifting the machine	2-1

## 2:1 LIFTING AND TRANSPORTATION

### Unloading (Fig 1)

Verify the weight of the machine (see Installation Data). Ensure that all lifting equipment used is capable of lifting this weight as a minimum.

The machine is despatched from the factory complete with lifting bars and shackles.

**Note:-** the machine must be lifted with the hood fitted

The lifting bars have been positioned to ensure a straight lift provided the chain lengths (3) are kept equal.

The angle  $a$  between the chains must not exceed  $90^\circ$ .

When the machine is in its final position the lifting bars (1) must be removed by unscrewing the four capscrews (2) on each bar.

### Moving

In the process of moving, avoid jolting or vibrating the machine. If the ground is flat the machine can be positioned on wooden plinths and moved by rollers instead of lifting.

### Unpacking

Undo the packing and make sure that damage has not occurred during transit; undo the case of accessories and ascertain that the machine is complete with all fittings.

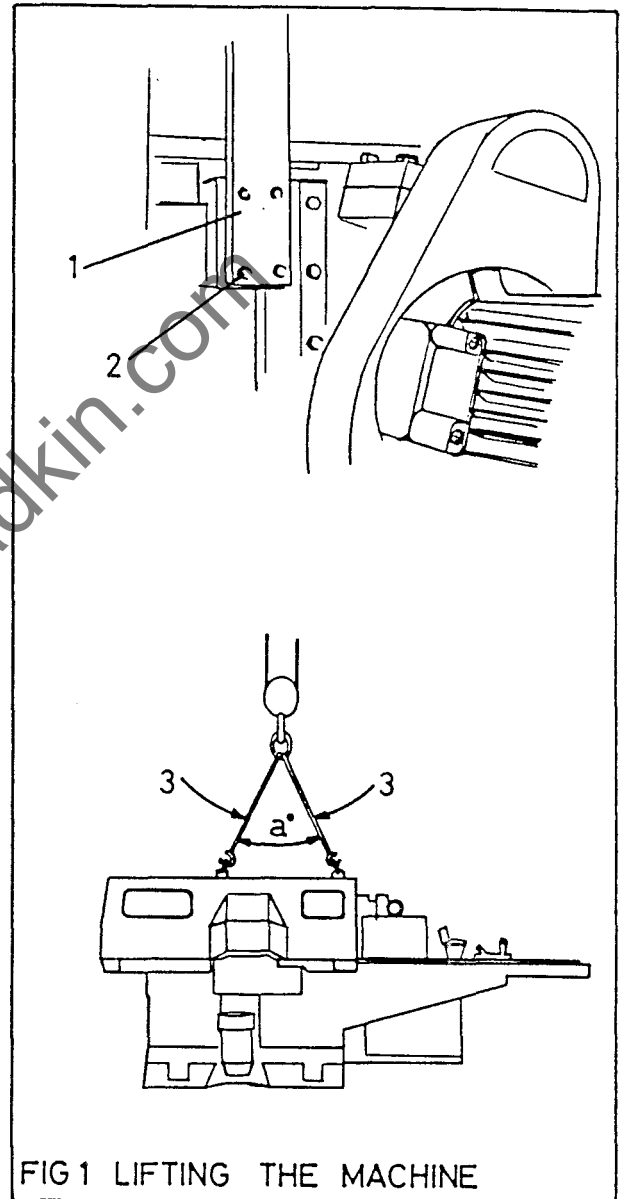

FIG 1 LIFTING THE MACHINE

### Cleaning

Before levelling the machine, carefully remove the anti-rust material particularly from the bright parts.

Clean the machine with paraffin or diesel and a soft rag. Do not use a substitute - it may precipitate an explosion.

## 2 : 2 INSTALLATION DATA

### Major Dimensions and Weight

#### *Overall Dimensions and Weights:*

Five Head machine  
Length: 3700mm  
Width: 1600mm  
Height: 1600mm  
Weight: 2400kg

### Location and Foundations

To obtain the best results from the 'Wadkin' woodworking machine it is important that the floor on which the machine is to stand has been prepared and is dry. Level the machine from the middle of the bed between the adjustable screw supports by the use of a spirit level. Place the steel plates supplied with the machine under the adjustable levelling screws.

#### *Suggested levelling aids:*

Straightedge 2 metres long  
Feelers (thickness gauges), 0.50, 0.10, 0.15 and 0.2mm  
Engineer's spirit level  
Rule 1 metre long, 0.2 mm graduations

#### *Levelling longitudinally*

Place the spirit level on the table and moving the level lengthwise check any variation. Adjust machine level by use of the adjustment screws in the feet of the machine. Deviation should not be more than 0.2 mm.

The straightening table (ie: table before the First Bottom Head), should be in line with the table after the First Bottom Head. Maximum tolerance is 0.1mm in 1600mm.

#### *Levelling transversely*

Place the spirit level across the table at right angles to the fence and repeat this action at intervals of 800mm. Total variation at each position should not exceed 0.1mm.

#### *The foundations*

The size of the foundations depends upon the specific machine model, format of the heads and disposition of the exhaust outlets and will be provided for individual machines.

If the floor consists of 100mm-150mm (4 to 6 inches) solid concrete, no special foundation is necessary. M12 'HLN' type holding down bolts (not supplied with the machine) can be used to secure the machine to the floor.

**NOTE: THE MACHINE MUST BE BOLTED DOWN BEFORE USE**

See Foundation Plan for details of floor area required.

### Supplies and Services

#### *Electrical Supply*

The customer is responsible for an adequate electrical supply. Details of power requirements are provided with the machine.

The machine is delivered with its complete electrical equipment ready for connection.

The electrical connection and schematic diagram are found in the electrical control cubicle of the machine. All that is required is to connect the power supply to the disconnect (Isolator) switch at the electrical control cubicle or panel.

#### **POINTS TO NOTE WHEN CONNECTING THE POWER SUPPLY**

Check the voltage, phase and frequency correspond with those on the machine nameplate details.

Check the main fuses are of the correct capacity in accordance with the machine nameplate details.

Connect the incoming supply leads to the appropriate terminals.

Check all connections are sound and that equipment is earthed.



Check the spindle rotation is correct. When looking from the front of the machine the feed rolls should rotate in a clockwise direction. To reverse the rotation on any drive, reverse any two of the line lead connections at the incoming supply.

**IMPORTANT:** ANY ELECTRICAL MODIFICATIONS SHOULD BE CARRIED OUT BY A COMPETANT ELECTRICIAN.

*Pneumatic pressure equipment (where fitted).*

Where the machine is equipped with pneumatic pressure operated feedrolls, the number of connections are shown on the pneumatic circuit diagram and foundation plan. To make the system operative connect up the air pipes and fittings to a suitable air supply.

The size of the air inlet connection is 1/4in. BSP female.

The size of the air pipe is 8mm O.D. x 5mm I.D.

Pressure required is 6 bar (approx. 90 psi), see **Operating Instructions** for feedroll pressures.

The air consumption is approximately 200 cu.dm/hr (7cu.feet/hr).

*Exhaust (Dust Extraction) Connections*

The size of the connections are given on the Foundation and Dust Extraction Plan.

The part of the air extraction pipe fitted to the exhaust hood should be flexible and detachable. The length of the flexible part is dependant on the way the pipe is used and the adjustment required on the work spindle. As a guide use a flexible pipe one metre long for the lower and fence side spindles and two metres for the top and near side spindles.

The flow of air to the exhaust hoods should be approximately 25 to 30 metres per second.

*Volume of Air Required*

For Horizontal/Vertical Spindles	17-20 cu. metres/ min ( per head ) (600-700 cu.ft/min)
----------------------------------	--

The total volume of air required for the Dust Extraction is directly related to the total number of spindles.

*Schematic Diagram for Electrical Services*

The electrical wiring and schematic diagram will be in the electrical control cubicle of the machine.

## SECTION 3

# OPERATING INSTRUCTIONS

	<b>Content</b>	<b>Page</b>
3:1	<b>General Information</b>	
	Safety	3-1
	Safety devices	3-1
	Warnings	3-1
	Machine controls	3-2
	Cutters and tool holders	3-2
3:2	<b>Mounting the Cutterblocks</b>	
	General	3-5
	First bottom head	3-5
	Fence side head	3-6
	Near side head	3-7
	Top head	3-8
	Second bottom head	3-8
3:3	<b>Setting up the Machine</b>	
	Set infeed table	3-11
	Set feed rolls	3-11
	Check/adjust fence side head	3-12
	Check/adjust near side head	3-12
	Check/adjust top and second bottom head	3-12
	Final adjustments and settings	3-13
3:4	<b>Faults in the Workpieces and their Causes</b>	
	General	3-15
	Faults caused by tools	3-15
	Faults in Grinding and setting	3-15



OPERATING INSTRUCTIONS (cont.)

	<b>Content</b>	<b>Page</b>
3:5	<b>Cleaning the Machine</b>	3-17
3:6	<b>Dial-a-Size Electronic Positioning</b>	
	Near Side and Top Head	3-19
	Setting	3-19
	Method of operation	3-20
3:7	<b>99 Setting Programable Memory Positioning</b>	
	Near Side and Top Head	3-21
	Setting	3-22
	Method of operation	3-23

www.DaltonsWadkin.com



## SECTION 3

### LIST OF ILLUSTRATIONS

	Description	Page
3:1	<b>General Information</b>	
	Fig 1 Machine controls — general view	3-3
3:2	<b>Mounting the Cutterblocks</b>	
	Fig 1 First bottom head	3-5
	Fig 2 Hand controls — first bottom head	3-6
	Fig 3 First bottom head (setting cutterblock)	3-6
	Fig 4 Fence side head (setting cutterblock)	3-6
	Fig 5 Hand controls — fence side head	3-7
	Fig 6 Near side head (setting cutterblock)	3-7
	Fig 7 Hand controls — near side head	3-7
	Fig 8 Top head (setting cutterblock)	3-8
	Fig 9 Hand controls top head	3-8
	Fig 10 Second bottom head (setting cutterblock)	3-9
	Fig 11 Hand controls second bottom head	3-9
3:3	<b>Setting up the Machine</b>	
	Fig 1 Infeed table setting	3-11
	Fig 2 Feed rolls setting	3-11
	Fig 3 Feed rolls spacer detail	3-11
	Fig 4 Fence side head setting	3-12
	Fig 5 Nearside head and chipbreaker	3-12
	Fig 6 Top and second bottom head setting	3-13
	Fig 7 Final adjustments and settings	3-13
3:7	<b>99 Setting Programable Memory Positioning</b>	
	Fig 1 Control panel	3-21

### 3:1 GENERAL INFORMATION

#### Safety

The safe operation of woodworking machinery requires constant alertness and close attention to the work in hand.

Read this instruction manual, the Preface, and the Safety Notes carefully before operating the machine.

Blunt cutters often contribute to accidents. An efficient machinist knows when sharpening is necessary, but if there is reluctance to spend time on grinding and resetting, the cutters may run beyond their efficient limits and instead of cutting efficiently and smoothly they will tend to chop and snatch at the workpiece. This not only increases the risk of accidents but also lowers the quality of work.

Customers are strongly advised at all times to use high tensile cutterblock bolts which should be tensioned by means of a torque spanner. When choosing cutterblocks ensure they are suitable for the minimum cutting speed of the machine.

It is recommended that personnel involved with the machine are acquainted with the Woodworking Machines Regulations 1974 and also Booklet No. 41 'Safety in the use of woodworking machines', issued by the Department of Employment and available from Her Majesty's Stationery Office. Also BSI Code of Practice 'Safeguarding Woodworking Machines' Part 1 BS 6854.

#### Safety Devices

The safety covers and dust hoods must be closed during the time the machine is running. Cover the non-used part of the cutterblocks with the guards provided.

Only remove the feed roller guard when changing rollers and with spindles switched off at the control panel.

Do not work spindles if the spindle nuts or intermediate collars are not securely tightened.

Only remove the cover of the drive belt housing when changing or retensioning belts. The drive spindle must be stationary before making any adjustments.

#### WARNINGS

##### Notice to Operators

Read and follow the guidelines given in Safeguarding Machines and Safety Notes which are repeated on the front of the machine.

##### Before operating the machine

Ensure that all guards and fences are securely fitted and correctly adjusted. Guards and other safety devices are NOT to be removed while the machine is in operation. They are there for YOUR SAFETY.

Ensure cutters/blades are the correct type and rotate in correct direction of cut, are sharp and securely fastened.

Cutter equipment is suitable for machine spindle speed.

Remove or fasten loose clothing; confine long hair and remove jewellery, etc.

Ensure sufficient working space is provided and that lighting is adequate.

Switch on all dust extraction equipment, ensure it is working correctly.

##### During machining

Wear suitable protective equipment, e.g. goggles, ear defenders, dust mask.

Stop the machine before making adjustments or cleaning woodchips from the work area.



## SECTION 3

## OPERATING INSTRUCTIONS

Keep the floor area around the machine clean and free from wood refuse.

Do not allow the floor to become slippery with oil or grease.

Report any machine malfunction or operator hazard to a person in authority immediately. Do not attempt to repair the machine unless qualified to do so.

Ensure all power sources are isolated before commencing any maintenance work.

Comply with the Woodworking Machines regulations. Failure to do so could result in legal proceedings.

### Machine Controls (Fig 1)

Before starting the machine, operators should familiarise themselves with the various controls and their usage (Fig 1).

Check direction of spindle rotation, ensuring that the spindles rotate freely. Check each spindle motor separately.

Check the infeed table raise and lower operation.

The machine has continuous feedworks. When started, timber stock will be fed to the cutter heads until the pass is completed or the machine is stopped. The feed speed is variable and can be adjusted by a handwheel at the drive gearbox to give throughput speeds between 6 and 22 metres a minute. **Only adjust the variable speed drive while in motion.**

The feed rolls have serrated teeth up to the top cutter head after which they are rubber covered. The serrated rolls need to be adjusted to 3mm lower than the thinnest workpiece; the rubber covered rolls should be adjusted to 1mm lower than the workpiece.

Adjustment of the feed rolls is made by pressing the pushbuttons marked:



— raise feed rolls

— lower feed rolls

The pushbuttons are positioned on the Electrical Control Panel located at the infeed end of the machine and also at the control station located at the outfeed end of the machine.

The adjustment for height of the rubber covered (plain) rolls may be made independently to suit the finished workpiece.

The panel mounted control station at the infeed end of the machine contains the following features:

- START-STOP Pushbutton;  
with indicator light, for each spindle.
- START-STOP Feed Pushbutton;  
with indicator light.
- FORWARD-REVERSE  
(Inch) Feed Pushbuttons.
- RAISE-LOWER Pushbuttons;  
for beam adjustment.
- MASTER STOP (Emergency) Button.

### Cutters and Tool Holders

When choosing cutters, make sure they are suitable for the spindle speed. Dynamically balance and check for defects and cracks.

The life of a cutterblock is directly related to the quality of the steel and nature of timber to be worked. It is impossible to give exact values of cutter life; the following is a guide.

High speed steel	HLS	2 - 5 hours
Very high speed steel	HSS	3 - 8 hours
Carbide steel	HM	20 - 70 hours

Honing at regular intervals will prolong the life of the cutters.

When regrinding cutters it is very important to ensure the edge does not become overheated. Overheating can be prevented if light grinding cuts are taken.

Ensure that all cutters of a multiple cutterblock are the same, the objective being all should cut the timber evenly and equally.

The performance of any tool depends to a large extent on the care in the way it is used. The life of the cutters and the surface finish of the workpiece are directly related to the care which is given to the work.

### 3:2 MOUNTING THE CUTTERBLOCKS

#### General

To change cutterblocks, remove dust hood covers and unscrew the cutterblock nut from the spindle with the combination spanner supplied with the machine.

- (1) Place the combination spanner on the hexagon of the spindle and on the two flat faces of the cutterblock locknut.
- (2) Hold the spanner (top) securing the spindle firmly in position and unscrew the cutterblock locknut with the bottom spanner.

**NOTE:** Spindles have right or lefthand threads as follows:

- Bottom Horizontal spindle — left-hand thread
- Near Side Vertical spindle — left-hand thread
- Top Horizontal spindle — right-hand thread
- Fence Side Vertical spindle — right-hand thread

**DO NOT** use any form of percussion tool on the cutter heads, damage to spindle bearings can result. **DO NOT** use a boxspanner or an extension spanner.

- (3) Carefully clean the spindles, cutterblocks, sleeves and any intermediate spacers before refitting.
- (4) After fitting, turn the spindle by hand to ensure the cutterblock is free. Close the cover.
- (5) Operate the spindle for a short period to ensure it rotates freely and without vibration.

#### CAUTION

On vertical spindles take care not to allow the cutter block to fall onto the spindle shoulder while fitting. This can cause damage and subsequent vibration.

#### First Bottom Head (Fig 1, Fig 2, Fig 3)

- (1) Remove guard for access, remove existing cutterblock as follows:
  - a. Release cutterblock (1) using the combination spanner provided on the spindle hexagon (2) and the two flat faces of the cutterblock locknut (3).
  - b. Withdraw cutterblock from spindle.
- (2) Check that the spindle (4), flange (5) and the flange end of the replacement cutterblock are clean.

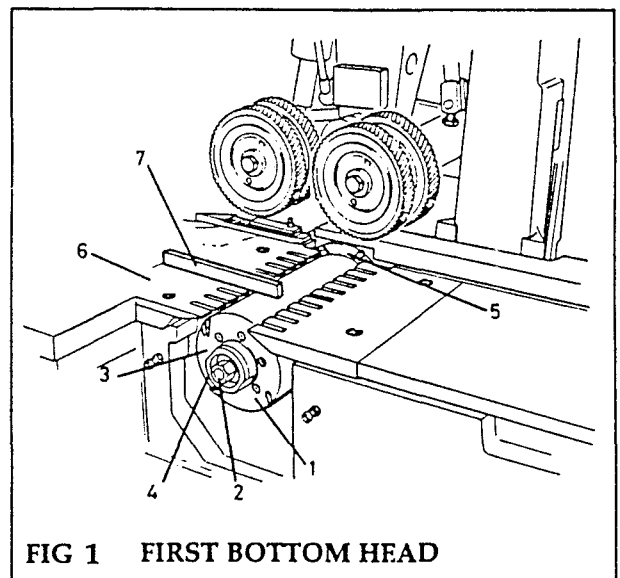

**FIG 1 FIRST BOTTOM HEAD**

- (3) Slide the new cutterblock (1) onto the spindle (4) and tighten using the combination spanner provided.

**NOTE:** Do not use excess force.

- (4) Ensure the outfeed table (6) is clean.
- (5) Place a straightedge (7) on the outfeed table projecting over the bottom horizontal cut-

## SECTION 3

## OPERATING INSTRUCTIONS

terblock (1). The cutter blades should just touch the underside of the straightedge. If necessary, reset the cutter height as follows:

- a. Release locking handle (8) and adjust the cutterblock height by rotating the hand-screw (9) clockwise to raise the spindle, or anticlockwise to lower.
- b. Refasten the locking handle (8).

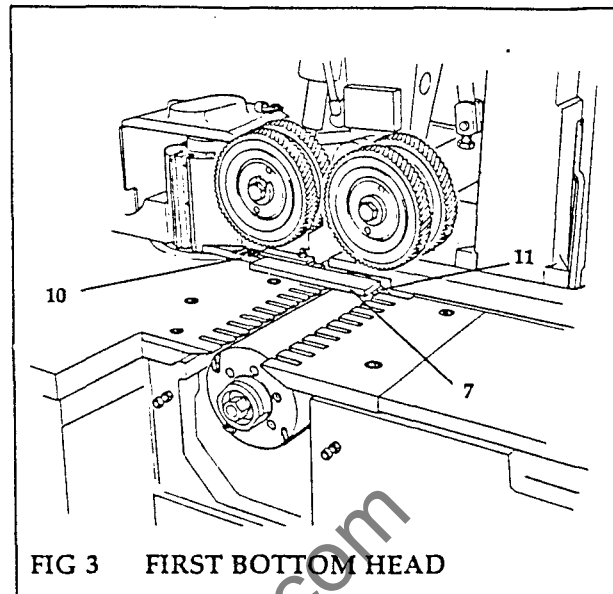
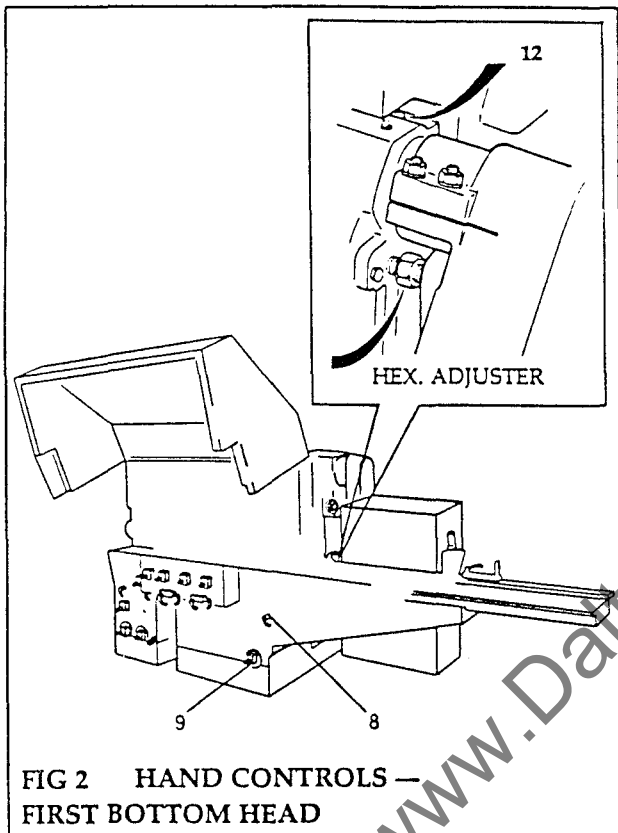

FIG 3 FIRST BOTTOM HEAD

a similar manner to that used for the First Bottom Head. If necessary adjust the spindle laterally as follows:

- a. Release the locking handle (4).
- b. Rotate the handscrew (5) clockwise to advance the spindle or anticlockwise to retract the spindle.
- c. Refasten the locking handle (4).

**NOTE:** Maximum lateral adjustment is 65mm.

- (6) Place the straightedge (7) against the out-feed fence guide (7) and check that the cutter flange (11) is in line with the guide (ie; just touching the straightedge). If necessary, adjust the cutterblock laterally as follows:

- a. Release the hexagon nut (12) on the bottom head vertical slide casting at the rear of the machine and rotate the spindle adjuster as required.
- b. Retighten the hexagon nut (12).

### Fence Side Head ( Figs 4 , Fig 5 ).

- (1) Ensure that the machine bed is clean.
- (2) Set the fence guide (1) with a straightedge (2) against the fence guide and cutters (3) in

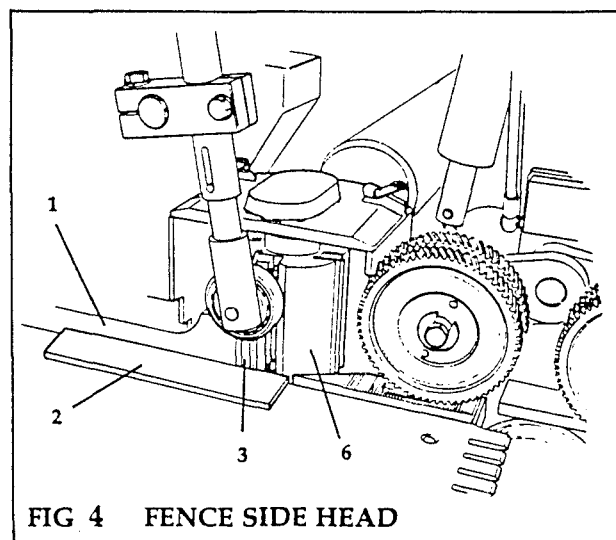
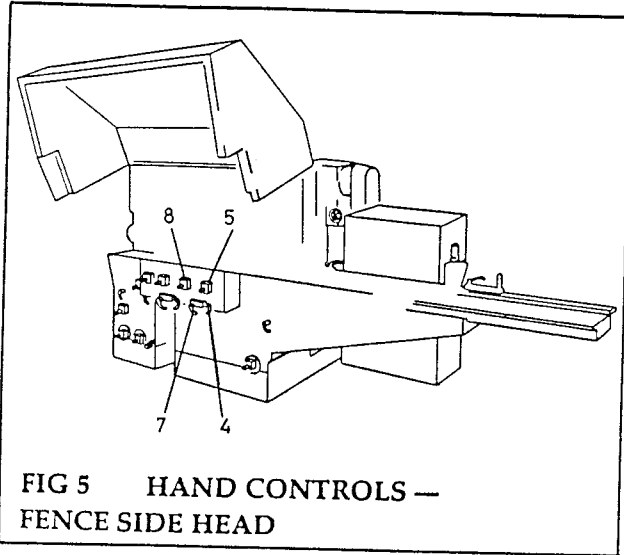

FIG 4 FENCE SIDE HEAD

- (3) Set the axial position (height) of the cutterblock (6) as follows:
  - a. Release the locking handle (4).
  - b. Release the spindle clamp (7) and adjust cutter height by rotating the handscrew (8) anticlockwise to lower or clockwise to raise the spindle.
  - c. Refasten the locking handle (7).



- c. Refasten the spindle clamp (7)
- d. Refasten the locking handle (4).



The cutterblades should just touch the near side of the datum block. If necessary, reposition as follows:

- a. Release locking handle (5).
- b. Rotate handscrew (6) clockwise to advance the spindle or anticlockwise to retract the spindle.
- c. Refasten locking handle (5).
- d. Reset digital readout, where fitted, to the known dimension.

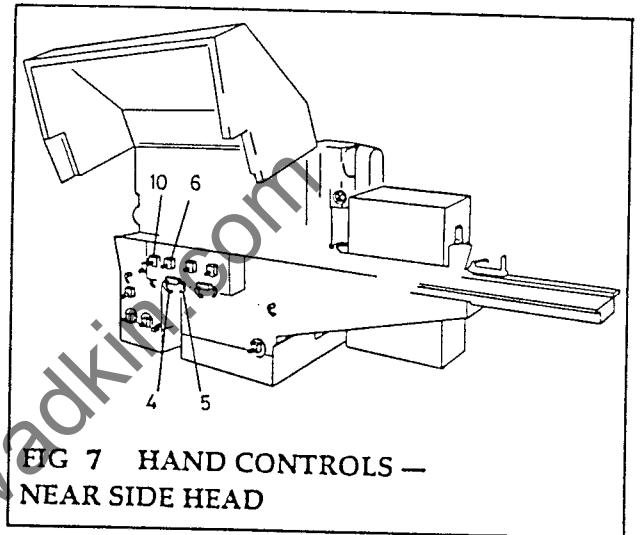

Near Side Head (Fig 6 , Fig 7 )

- (1) Ensure that the machine bed is clean.
- (2) Check the digital readout, using a datum block (1) of known width inserted between the fence guide (2) and cutter (3).

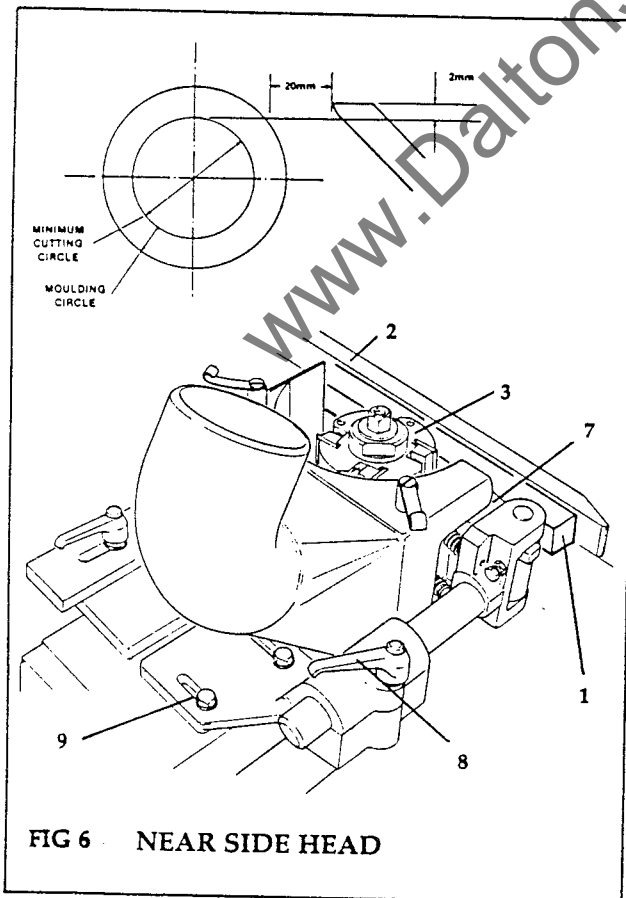

- (3) Set the axial position (height) of the cutterblock (3) as follows:
  - a. Release the locking handle (5).
  - b. Release the spindle clamp (4) and adjust the cutter height by rotating the hand-screw (10) anticlockwise to lower the spindle or clockwise to raise the spindle.
  - c. Refasten the spindle clamp (4).
  - d. Refasten locking handle (5).

- (4) Set the chipbreaker (7) as follows:
  - a. Remove the cover of the dusthood.
  - b. Release the locking handle (8)
  - c. Adjust the chipbreaker (7) so that it clears the smallest cutting circle by approximately 2mm.
  - d. Refasten the locking handle (8).
  - e. Unscrew the bolts (9) and adjust the chipbreaker (7) to suit the cutterblock diameter so that it clears the cutterblock by 20mm (Fig 6).
  - f. Retighten the bolts (9).

### Top Head (Fig 8, Fig 9)

- (1) Ensure that the machine bed is clean.
- (2) Using the same datum block (1) as in Near Side Head, set the cutter (2) as follows:
  - a. Release locking handle (3).
  - b. Rotate handscrew (4) clockwise to lower the spindle or anticlockwise to raise the spindle.
  - c. Refasten locking handle (3).
  - d. Reset digital readout, where fitted, to the known dimension.

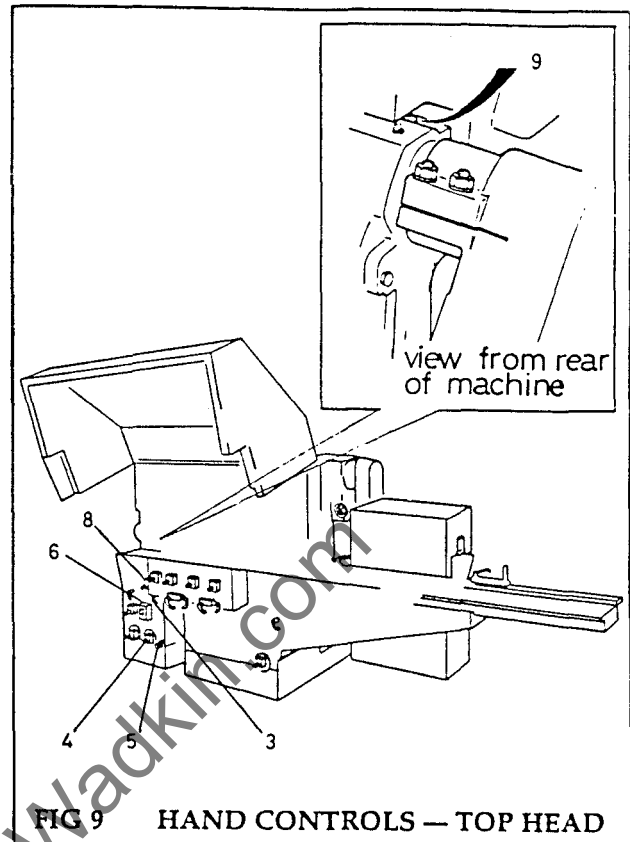
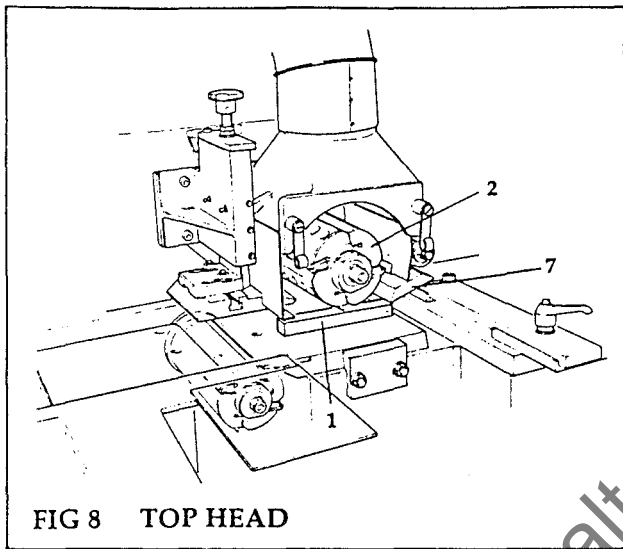

- (3) Adjust the spindle laterally as required, as follows:
  - a. Release the hexagon nut (9) on the bottom head vertical slide casting at the rear of the machine
  - b. Release the locking handle (3) and turn the handscrew (8) clockwise to advance the spindle or anticlockwise to retract the spindle.
  - c. Refasten the locking handle (3).
  - d. Retighten the hexagon nut (9).

**NOTE:** To use the automatic vertical adjustment: release locking handle (3), engage lever (5) and hold until clutch is engaged. If the clutch does not readily engage, operate the handscrew (4) by turning slightly (to right or left) until engagement is made. To raise or lower spindle, press the appropriate button at the control station (6).

The automatic vertical adjustment only works in conjunction with the powered height adjustment to the feedrolls. After positioning the spindle, lift the hand lever (5) to disengage the automatic vertical adjustment. Finally, if necessary, adjust manually with handscrew (4). Refasten the locking handle (3).

- (4) If necessary, change chipbreaker shoe (7) to maintain leading edge as close to cut as possible ie 20mm. Alternative lengths are provided see **Illustrated Parts List**.

### Second Bottom Head (Fig 10, Fig 11) — when fitted

- (1) Ensure the machine bed is clean.
- (2) Using a straightedge (1) as in setting up the First Bottom Head, set the cutter height by adjusting cutterblock (2). The blades of the cutter should just touch the underside of the straightedge. To reset cutter height:
  - a. Release locking handle (4), rotate handscrew (5) clockwise to raise the spindle, or anticlockwise to lower.
  - b. Refasten locking handle (4).

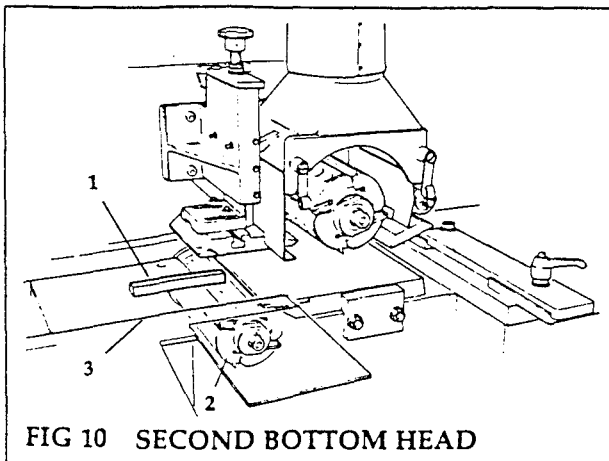

(3) Adjust the spindle laterally as required, as follows:

- a. Release the hexagon nut (7) on the bottom head vertical slide casting at the rear of the machine
- b. Turn the handscrew (6) clockwise to advance the spindle or anticlockwise to retract the spindle.
- c. Retighten the hexagon nut (7).

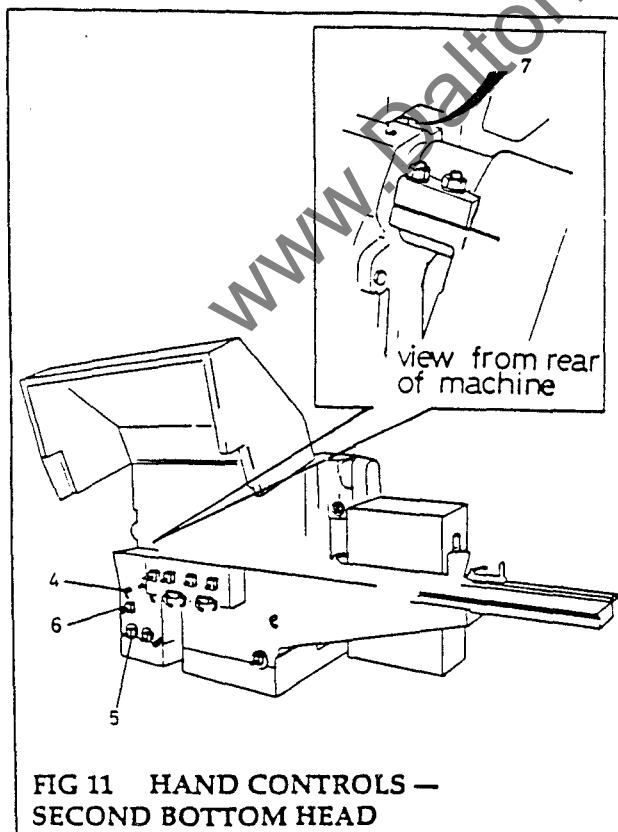

FIG 11 HAND CONTROLS —  
SECOND BOTTOM HEAD

### 3.3 SETTING UP THE MACHINE

Having mounted and checked the cutterblocks set the machine up in the following order:-

#### Set Infeed Table (Fig 1)

- (1) Isolate power at mains or at master stop.
- (2) To set the height of the infeed table (1), unclamp table by turning the locking handle (2) in an anticlockwise direction. Set the height from reading on the graduated scale (3) by moving handle to right or left as required. Secure table in position by turning handle (2) in a clockwise direction. The maximum adjustment available is 10mm.
- (3) Set the fence (4) adjustment with handle (5) after releasing clamp (6). Refasten clamp (6) after adjustment. Set the amount of cut required by direct reading on the scale (9).

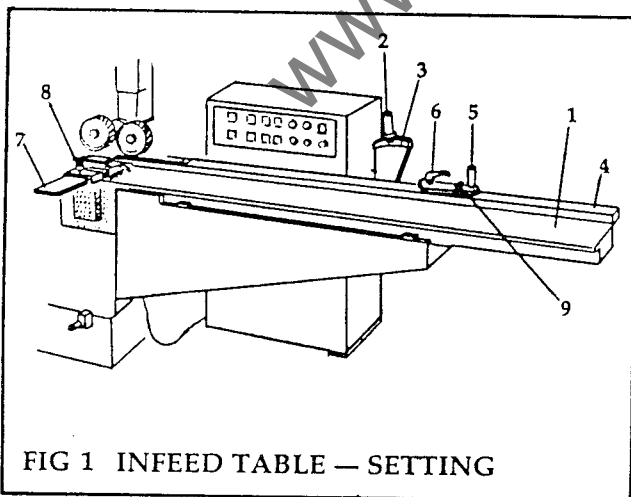

FIG 1 INFEED TABLE — SETTING

- (4) The adjustable guard (7) must be set to within 5mm of the maximum timber size. Slacken star handwheel (8), set guard (7) and retighten handwheel.

#### Setting Feed Rolls (Fig 2, Fig 3)

Feed rolls should generally be set 3mm lower than the thinnest workpiece except for the outfeed rollers which should be set 1mm lower.

To achieve maximum traction on wide timber it is advisable where appropriate to space rollers apart to cover timber width rather than having a solid bank.

**Caution:** Serrated steel rolls have sharp edges and care should be taken when handling.

- (1) Ensure machine is isolated at mains or at master stop.
- (2) Space rolls to suit timber in the following manner:-
  - a) *Flange mounted*
    - i Slacken off the set screw (1) and remove 'C' washer (2), taking care that the washer does not fall off whilst unscrewing setscrew.
    - ii The feed rolls (3) and spacers (4) can now be removed and re-spaced to suit timber requirements. Ensure drive pins and shoulders of feed rolls and spacers are all properly engaged. The setscrew (1) may need to be unscrewed if extra rollers or spacers are to be fitted.

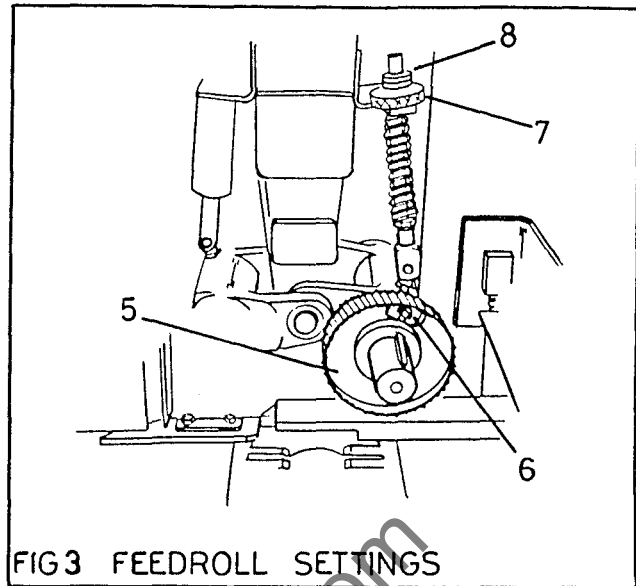
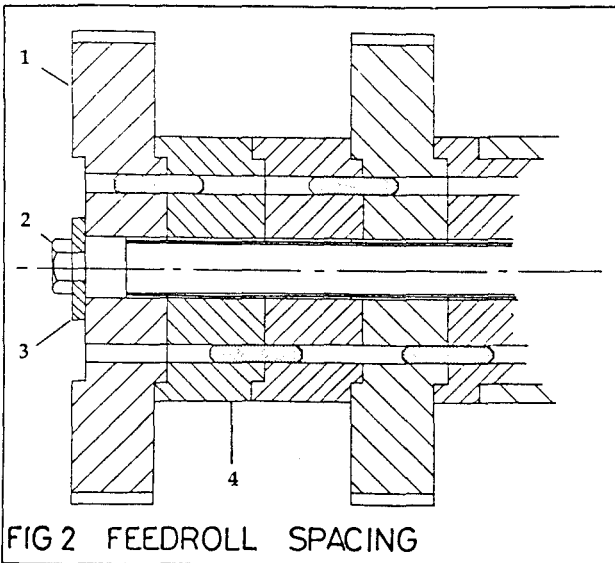

*b) Shaft mounted*

- i To reposition shaft mounted feed rolls (5) slacken off setscrew (6) (ensuring shaft is clean) slide rolls along shaft and position to suit timber width.
- ii When in position tighten up setscrews (6).
- (3) Feedroll height setting should all be set initially at the same height above bed level. Movement of the beam and thus the feed rolls is via the buttons marked '↓' and '↑' on the control pump. Power will need to be re-engaged at this point.

Adjustment to individual rolls (where fitted) is by turning the handwheel (7) clockwise to raise or anticlockwise to lower, having first slackened of the locking thumb nut (8).

- (4) Once the feed rolls are set inch the timber through the machine, stoping just prior to the fence side head.

**Adjustment at Fence Side Head (Fig 4)**

- (1) Isolate machine at mains or at master stop.
- (2) Adjust the side roller pressures (if fitted) to the timber so that moderate force is exerted on the timber. Adjust the side rollers (1) by unscrewing the two nuts (2) and adjusting side rollers to suit width of stock.

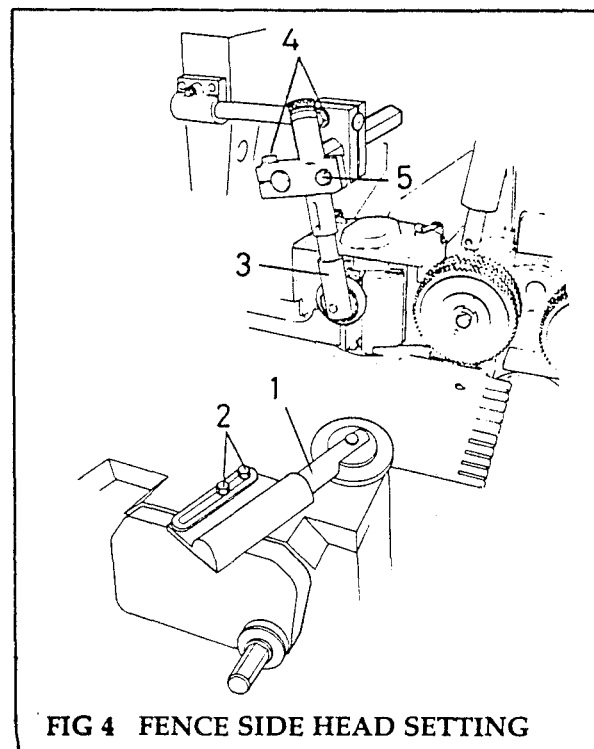

**FIG 4 FENCE SIDE HEAD SETTING**

- (3) Adjust the top roller pressure to the timber as follows:-

Adjust the top roller (3) by loosening screw (4) for lateral adjustment and right hand screw (5) above the roller for height adjustment. Retighten screws.

**Check/Adjust at Near Side Head (Fig 5)**

- (1) Check the setting of the chipbreaker (1) adjacent to the near side head. Reset if necessary, using the locking handle (2) to release slide bar (3). Retighten locking handle (2).
- (2) Re-engage power and inch timber through machine up to top cutter.
- (3) Release locking handle (4) and set side guide (5) after near side head to the timber width as machined. Refasten locking handle (4).

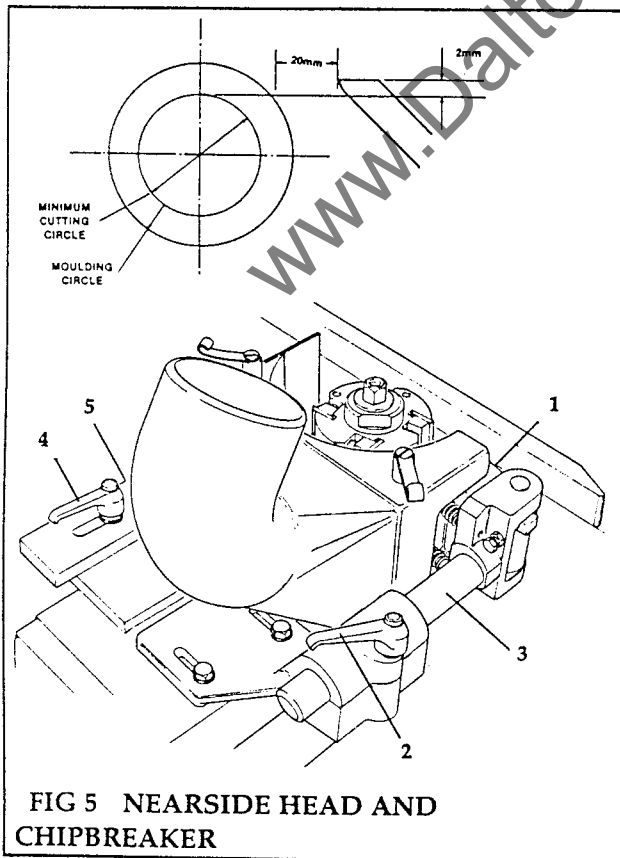

**FIG 5 NEARSIDE HEAD AND CHIPBREAKER**

**Check/Adjust at Top and Second Bottom Head (Fig 6)**

- (1) Inch timber through all spindles and stop with timber over second bottom head. Isolate machine at mains or at master stop.
- (2) If necessary, reset pressure pad after top head to new dimensions of timber as follows:-
  - a) Loosen two screws (1) then slide pad (2) laterally.
  - b) Retighten screws.
- (3) Adjust pad pressure to timber thickness using starwheel (3).
- (4) Set side guide (4) by slackening screws (5), slide guide laterally to hold timber to rear fence without trapping. Retighten screws.
- (5) Reset outfeed rolls (6) height to suit timber if required.

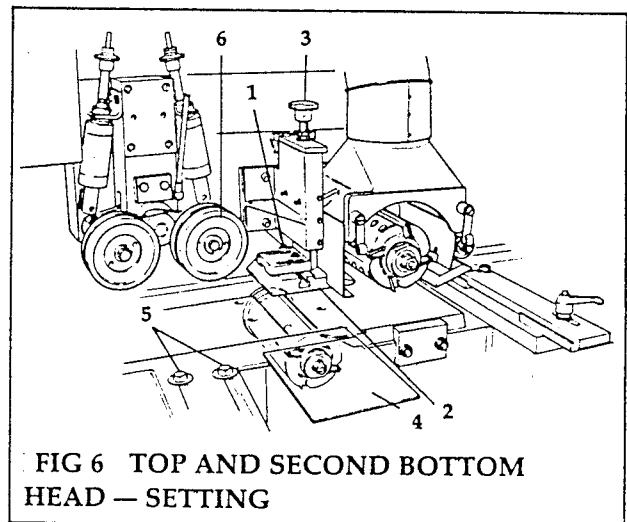

**FIG 6 TOP AND SECOND BOTTOM HEAD — SETTING**

**Final Adjustments and Settings (Fig 7)**

- (1) Examine and measure timber passed through while setting. If necessary adjust cutterblocks to produce desired machined dimensions.
- (2) Check infeed (serrated) feed rolls (1) for height setting.
- (3) Check the plain feed rolls (2) suit the new dimension of the workpiece.
- (4) When fitted with pneumatic loading set the air pressure on feed rolls (2) using the air supply regulators (3) and associated gauges.

**NOTE:** The first regulator and gauge is for the rolls up to the top head (1), this should be set to a lower pressure than the plain rolls (2).

The following pressures are recommended (but dependent on timber width).

- a. Steel rolls 3 bar (1 bar = 14.5 psi)
  - b. Rubber covered rolls 4 bar
- (5) On standard machine, set the spring pressure on feed rolls manually, using the hand adjuster screws on spring tensioners (4).
    - a. To increase spring pressure, turn the knurled screw on the top of the spring tensioner in a clockwise direction. To decrease spring pressure, turn the screw anticlockwise.
    - b. If the screw is turned through a distance of 5mm, pressure on roller is approximately 250N (25kg). If the screw is turned

through a maximum distance of 16mm, pressure on roller is approximately 500 N (50kg).

- (6) Check pressure pad adjustment (5) after top head. Raise or lower by use of the starwheel.
  - (7) Set the machine feed speed by rotation of the handwheel on the speed indicator dial with the machine running.
- NOTE:** DO NOT adjust with machine feed stationary.
- (8) Pass a test piece through the machine and check the timber dimensions and profile. Re-adjust where necessary.

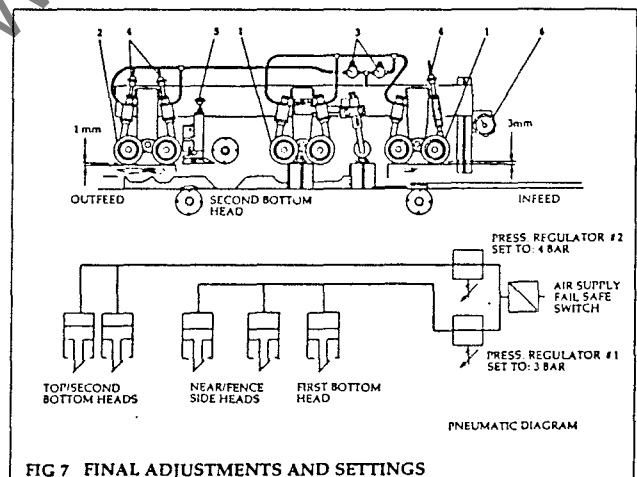

### 3 4 FAULTS IN THE WORKPIECES AND THEIR CAUSES

#### General

- |   |  |
|---|--|
| <b>FAULT</b> — Blips at the leading end of the underside of the timber.         | <b>FAULT</b> — The trailing end of the top face of the timber shows blips. |
| <b>Cause</b> — The cutterblock is too low in relation to the outfeed bedplate.  | <b>Cause</b> — Pad and roller pressures are incorrectly adjusted.          |
| <b>Remedy</b> — Adjust the cutterblock correctly.                               | <b>Remedy</b> — Adjust the pad pressures correctly                         |
| <b>FAULT</b> — Scars on the trailing end of the underside of the timber.        |  |
| <b>Cause</b> — The cutterblock is too high in relation to the outfeed bedplate. |  |
| <b>Remedy</b> — Adjust the cutterblock correctly.                               |  |

#### Faults Caused by Tools

- |   |   |
|---|---|
| <b>FAULT</b> — Out of square stock after planing.   | <b>FAULT</b> — Burn marks on the stock.               |
| <b>Cause</b> — The cutters are not parallel to the outfeed bedplate, or are badly ground. | <b>Cause</b> — Cutters are blunt and need regrinding. |
| <b>Remedy</b> — Adjust, or sharpen the cutters carefully                                  | <b>Remedy</b> — Regrind cutters.                      |

#### Faults in Grinding and Setting

- |  |   |
|--|---|
| <b>FAULT</b> — Nicks in the edges of the cutters especially carbide.   | <b>FAULT</b> — Vibrating heads                            |
| <b>Cause</b> — Generally caused by removing too much metal when regrinding. This results in undue stresses and subsequent cracking and breaking away of the cutting edge when machining. | <b>Cause</b> — Cutterblocks have been set up incorrectly. |
| <b>Remedy</b> — Take greater care when regrinding cutters.   | <b>Remedy</b> — Reset.                                    |



### 3:5 CLEANING THE MACHINE

Machines are designed to need a minimum of maintenance. However, it is recommended that the machine be cleaned thoroughly once a week. This is essential when working on hardwood such as Sipo (Utile) or similar.

If cleaning with compressed air, take care not to direct the jet onto the spindle and moving shaft, bearing housings, etc. Clean the spindles and remove all remains of resin and grease. Do the same with the cutterblock collars and

machine tables (bedplates) and lightly lubricate.

Check that all machine parts slide easily at friction points. Lubricate as indicated in the lubricating instructions (see **Maintenance**).

Adjust the variable speed drive unit through the full range once a week to avoid the feed drive mechanism jamming.

www.DaltonsWadkin.com

### 3:6 DIAL-A-SIZE ELECTRONIC POSITIONING

#### Near Side Head and Top Head

The powered traverse movement to the near side head is by a 'KEMO' geared motor.

The traverse movements of the heads are each connected to an 'encoder' which sends pulse signals to its respective 'Elgo' digital read out controller situated in the electrical control panel.

The traverse of the heads reacts to data put into the 'Elgo' controller which displays the cutterblock position in relation to its datum face. The datum face for the near side head is the fence. Datum for the top head is the bedplate.

The head traverse movements may be hand or power operated and a switch is provided for this purpose.

#### Setting Up

All setting parameters are available via the front keypad. Programming is inhibited until a link at the back of the unit is opened.

The programming link is in the form of a two terminal plug-in block, with a shorting wire. Unplug to set in parameters. Re insert plug to operate.

**NOTE:** The controller will not run with the link open.

Setting of the parameters is achieved as follows:

- (1) Press T, top display extinguishes and 'CH' is displayed. This ensures that the operator knows when the T button has been depressed (even by accident).
- (2) Enter functions [1] .....[5], 'CH' is extinguished. Title name is displayed in top window; value of parameter is displayed in bottom window.
- (3) Press C to clear existing value, enter required value.
- (4) Press T again to revert to operating mode.

The [T] functions/parameters are as follows:

[1] This sets the slowdown point during approach to position. 'SLSP' is displayed.

[2] This sets the stop correction offset. 'COR' is displayed.

[3] Saw width compensation is entered. 'SABL' is displayed.

[4] Time at standstill during backlash over-run and delay in drop-off of 'In Position' relay after drive stop is initiated.

'Ti' is displayed. Time can be set from 00.0 to 15.9 seconds. Also sets the auto retract time (ie; distance).

[5] This sets the decimal point position in the displays.

'DP' is displayed.

1 means units only, (ie; no decimal point).

2 means tenths displayed, (ie; one decimal place 0.0).

3 means hundreds displayed, (ie; two decimal places 0.00).

One [T] function is available with programme link either open or closed. That is Inch/Metric selection. This is used as follows:

- (1) Press [T], 'CH' appears in display.
- (2) Press [O], 'INCH' or 'MM' appears in display.
- (3) Press [C] to changeover.
- (4) Press [T] to revert to operation.

The decimal point is automatically moved and any actual value correctly recalculated. The set up parameters are also in the chosen units.

When [T] is pressed inadvertently, 'CH' is displayed to warn operator that he has pressed the button. Simply pressing [T] again returns controller to operating mode.

**NOTE:** All these parameters will be preset by Wadkin during the setting-up of the machine.

## Method of Operation

### To Set Datum

- (1) Switch to 'Hand' operation.
- (2) Determine the distance between the cutterblock and either the fence or bedplate, by use of a known thickness setting block or piece of timber; by hand winding the spindle up to the setting block.
- (3) Enter this figure using the keypad.
- (4) Press Datum pushbutton (Blue) on control panel.

These figures will be displayed on the demand value display (bottom window). The Datum figure is now set.

**NOTE: (a)** These Datum figures need only be re-set at machine switch-on, or if the cutterblocks are changed.

**NOTE: (b)** To hand set the height of the top horizontal spindle independently of the beam, disengage clutch (ie; operate changeover lever).

### To move the heads to a pre-determined position

- (1) Switch to 'Elgo' operation.
- (2) Enter the required position using the keypad.
- (3) Press 'Start' push button.

The head selected will now move automatically to the set position and the figures will be displayed in the actual value display (top window).

- (4) To move to a new position, repeat steps (2) and (3).

**NOTE:** The feed can only be inched in this mode.

### To run the machine

- (1) Switch to 'Auto' position.
- (2) The feed can now be run continuously, or inched.

www.DaltonsWadkin.com

### 3:7 99 SETTING PROGRAMABLE MEMORY POSITIONING

#### Near Side Head and Top Head

This unit has the capacity to be programmable for ninety-nine positional head settings.

The powered traverse movement to the near side head is by a geared motor.

The traverse movements of the heads are each connected to an 'encoder' which sends pulse signals to its respective digital read out controller situated in the electrical control panel.

The traverse of the heads reacts to data put into the controller which displays the cutter-block position in relation to its datum face. The datum face for the near side head is the fence. Datum for the top head is the bedplate.

The head traverse movements may be hand or power operated and a switch is provided for this purpose.

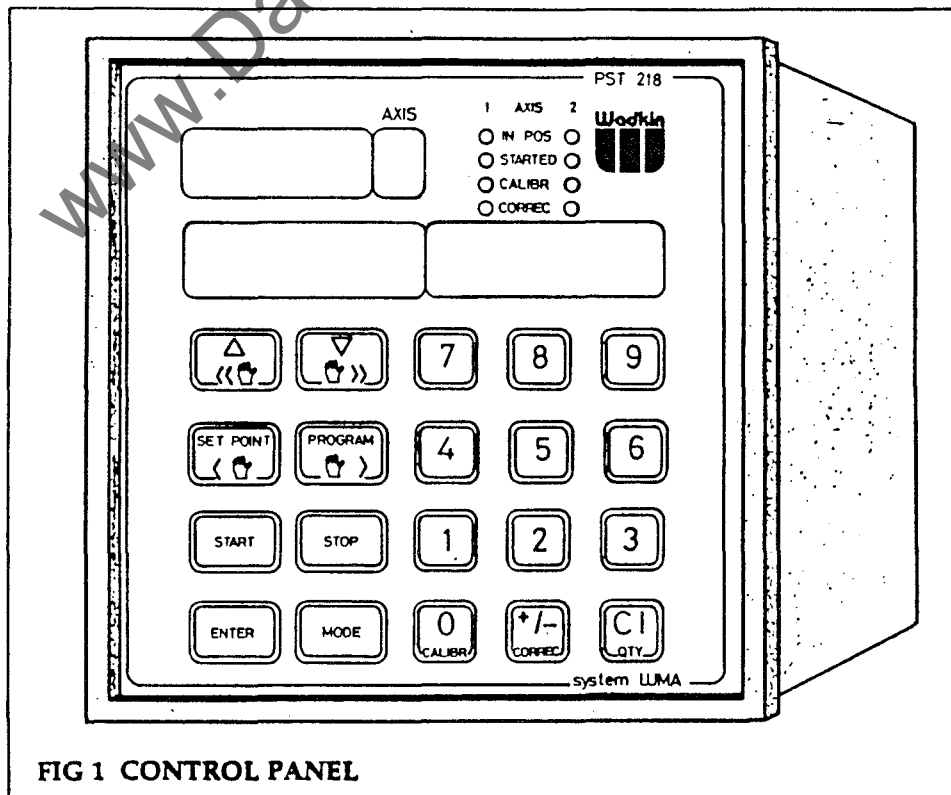

FIG 1 CONTROL PANEL

The illustrations (buttons) on the left hand side of each page show the buttons to be pressed, and in what order.

If buttons are shown with an '&' sign between them, they must then be pressed simultaneously.

### POSITIONING

PST 218

#### SWITCH ON MACHINE

#### CALIBRATION (Manual)

Each axis must be datumed before production is started.

The calibrating procedure is as follows:

The PST 218 unit can control 2 axes, both of which must be independently datumed.

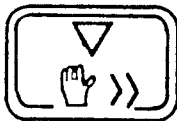

Push the button until the axis to be datumed (either axis 1 or axis 2) is shown as a number in the LED display.

AXIS

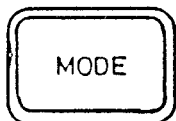

&



The mode and calibration buttons must be pressed simultaneously.

Enter new value.



Press enter.

The axis should now be datumed. Repeat the same operation for the second axis. When both axes have been datumed, the unit is ready for use.

Confirmation is in the top right of the unit where there are LED lights for each axis which represent the calibration.

**MANUAL POSITIONING**

The axis to be moved must be selected first.

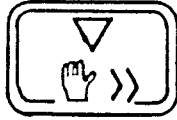

Push the button until the axis to be moved (either axis 1 or axis 2) is shown as a number in the LED display.

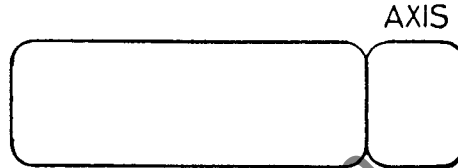

For manual positioning of the unit, the mode key and the direction of travel must be pressed simultaneously.

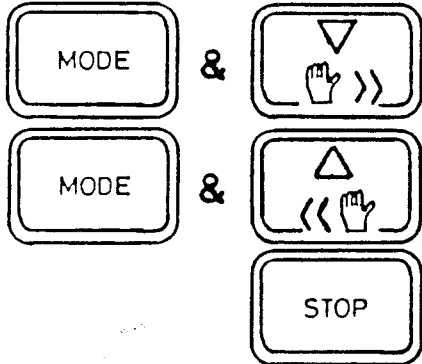

Move to a higher value than the position.

Move to a lower value than the position.

When manual positioning is finished, the stop button must be pressed to put the unit back into the automatic mode.

**DIAL-A-SIZE POSITIONING (SET POINTS)**

The axis to be moved must be selected first.



Push the button until the axis to be moved (either axis 1 or axis 2) is shown as a number in the LED display.

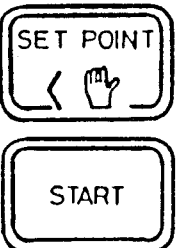
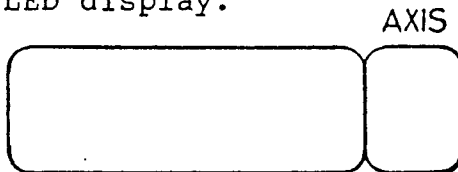

To use the Dial-A-Size option, this is simply a case of pressing the set point button and then the dimension.

Pressing the 'start' button will send the axis to the position.

When is position, an LED in the top right of the unit will be lit.

Whilst positioning is taking place, the 'started' LED will be lit.

**PROGRAM POSITIONING** (For programming of,  
see later  
instructions)

**CALLING UP PROGRAM**

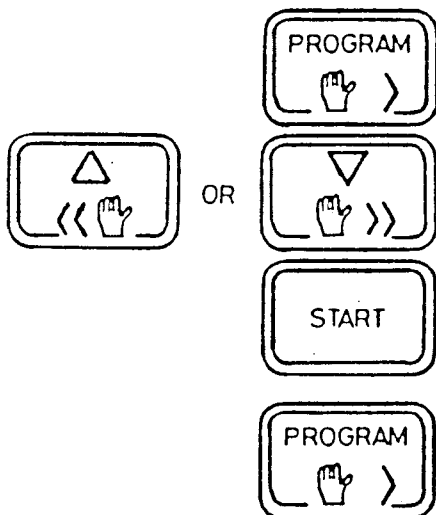

By press the 'program' button, the display will change to the program mode.

Pushing either of the two button will increase or decrease the program number to the one required.

Pushing the 'start' button will drive the axis to the position stated in the program.

NOTE: To escape from the program mode of the unit, press the 'program' button.

When the axis is in position, the 'in position' LED will be illuminated in the top right of the unit.

**PROGRAMMING OF THE UNIT**

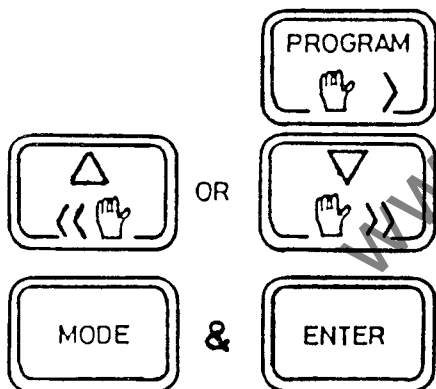

By pressing the 'program' button, the display will change to the program mode.

Push either of the two buttons until the program number required to be programmed is found.

The buttons 'mode' and 'enter' when pressed simultaneously will enable you to have the access to the program number that is illustrated in the display.

You will now have access to the axis.

Enter the required figures if a new number or an alteration.

NOTE: If the figures for axis 1 are correct and it is only axis 2 which has to be altered, you can press 'ENTER' without altering any figures will give you access to axis 2.



Pushing the 'enter' button will enter the figures into the memory and give you access to axis 2.

Enter the required figures.



Pressing the 'enter' button will enter the new figures into the memory.

The unit is now ready for use as 'calling up program'.



NOTE: Program P 0 is only for test purposes.

To clear existing information, press 'CL Qty' before entering new figures.

### TO USE THE RADIUS OFF-SET FEATURE

#### CALIBRATION (MANUAL)

The centre of both the left hand and top head spindle must be calibrated to use the off-set feature

Each axis must be datumed before production is started. **NOTE:** Maximum travel limit parameters may require changing. Calibration for using radius off-set is as follows:

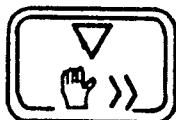

Push button until the axis to be datumed (either axis 1 of axis 2) is shown as a number in the LED display.

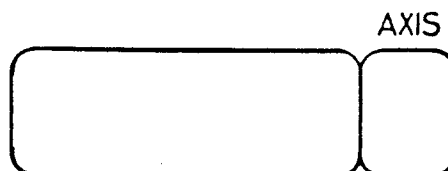



## SECTION 3

## OPERATING INSTRUCTIONS



&amp;



The mode and calibration buttons must be pressed simultaneously.

Enter the distance from the centre of the spindle to the bed, or fence, depending which axis is being calibrated.



Press Enter

The axis should now be datumed, repeat the same operation for the second axis. When both axis have been datumed, the unit is ready for use.

Confirmation is in the top right hand of the unit where there are LED lights for each axis, which represents the calibration.

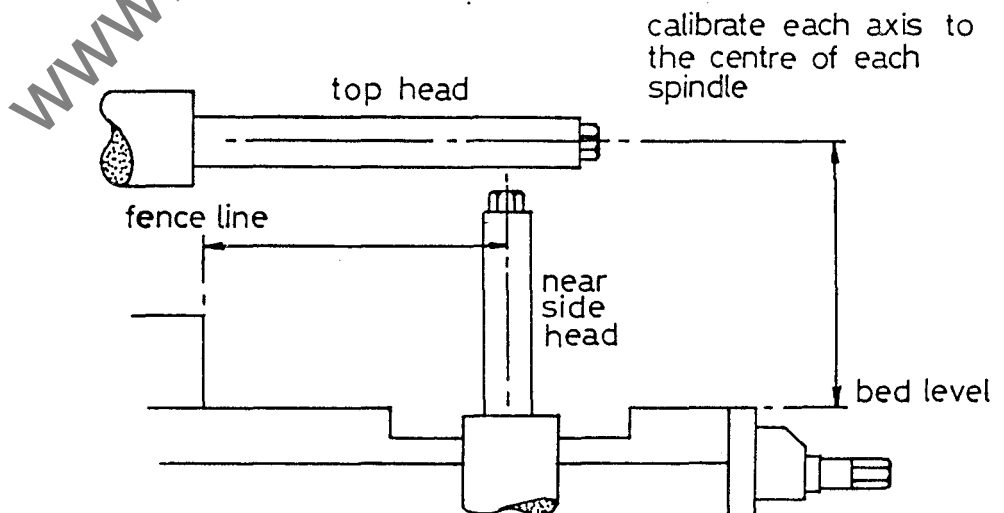

To enter the radius off-set

Measure and record the radius of the cutterheads to be used.



Push the button until the axis to be off-set (either axis 1 or axis 2) is shown as a number in the Led display.



&



The 'Mode' and 'Correct' buttons must be pressed simultaneously.

Enter radius value of the cutterhead for that particular axis.



Press 'Enter' twice.

Repeat the same procedure for the second axis.

When both axis have had the radius off-sets entered, the unit can be used as "calling up a program."

When the heads are moving into their programmed positions and, when they are in position, the display will show the relevant position of the centre of the spindle.



To display the actual "finished" size positions, of the cutterheads, push the 'program' button.



### FAULT FINDING

FAULT

Axis will not position accurately.

SOLUTION/CHECK

Check that unit is calibrated (LED top right if unit), recalibrate if necessary.

Physical object causing an obstruction. Remove object and check overload. Try again.

Movement is greater than the axis limits. Insert new figures.

Negative value in positioning memory.

www.DaltonsWadkin.com



PARAMETER SECTION - To enable the E.S.P System to function in either Metric (MM) or Imperial (inches)

PARAMETERS - This section should only be entered into by a competent person, who fully understands their function.

To enter into the parameter section, press 'mode' and '1', then '2' '0' '5'.

	<u>Imperial</u> Axis 1      Axis 2	<u>Metric</u> Axis 1      Axis 2
<u>Decimal Point</u> Display = PA. Pres '0' to change Press Enter		
<u>Calibration Method</u> Display = PAD Press Enter		
<u>Pre-Switch off Value/Over Run</u> Display = PA Press Enter This parameter to correct any positioning error due to "over run"		
<u>Tolerance Value</u> Display - PA Press Enter		
<u>Loop Mode</u> Positioning Direction Display = PAb Press Enter		
<u>Loop Value</u> Display = PAb Press Enter		



SECTION 3

OPERATING INSTRUCTIONS

<p><u>Delay Time</u> Display - PAde Press Enter</p>		
<p><u>Minimum Travel Limit</u> Display = PA= Press Enter</p>		
<p><u>Maximum Travel Limit</u> Display = PA Press Enter Note: If the radius off-set feature is used then the maximum travel limit should be</p>		
<p><u>Spindle Factor Counter</u> For Generator Matching Display = PA Press Enter</p>		
<p><u>Spindle Factor Denominator</u> Display - PA Press Enter</p>		
<p><u>Conversion (mm - Inch)</u> Display = PA</p>		

Press mode and then Enter to switch from Axis 1 to Axis 2, and go through the same parameters

When finished with both Axis 1 and Axis 2, press Mode and 1 to exit parameter section.

## SECTION 4

### MAINTENANCE

	Content	Page
4:1	<b>Scheduled Maintenance</b>	
	Lubrication	4-1
	Belt drive tensioning	4-1
	Cleaning	4-2
4:2	<b>Unscheduled Maintenance</b>	
	Changing cutterblock spindle bearings	4-3
	Preparation prior to fitting bearings	4-3
	Replacing drive belts	4-4
	Variable Speed Drive Unit	4-4
	Feed Rolls Drive and Gearboxes	4-5
4:3	<b>Fault Finding</b>	
	Mechanical faults	4-9
	Elimination of Vibration	4-9
	Electrical faults	4-9
	Approved lubricants	4-12
4:4	<b>Motor Drive Belt Data</b>	4-13

## SECTION 4

### LIST OF ILLUSTRATIONS

	Description	Page
<b>4:1</b>	<b>Scheduled Maintenance</b>	
Fig 1	Belt drive tensioning	4-1
<b>4:2</b>	<b>Unscheduled Maintenance</b>	
Fig 1	Spindle unit bearing assembly	4-3
Fig 2	Replacing drive belts	4-4
Fig 3	Variable speed drive unit	4-5
Fig 4	Feed roll drives and gearboxes	4-6

### Spare Parts

When ordering spare parts, all the data shown on the unit nameplate must be quoted, together with Reference Numbers from the Illustrated Parts List.

[www.DaltonsWadkin.com](http://www.DaltonsWadkin.com)



## 4 : 1 SCHEDULED MAINTENANCE

Scheduled maintenance consists of regularly maintaining the machine in a good operating condition, capable of safely producing good quality trouble free work, with the minimum of downtime.

This includes tasks such as daily/weekly cleaning and lubrication which can and should be performed by the operator. Tasks carried out at longer intervals will require more specialised knowledge and tools to perform.

### Lubrication

Much attention has been given to keeping lubrication and maintenance to a minimum. In consequence, 'sealed for life' bearings and 'Oilite' bushes have been used. The cutter-block spindles have been fitted with permanently lubricated bearings; these should only require replacement of lubricant if the spindle bearings are replaced. However, there are exceptions as follows:

Electric motors, where 'sealed for life' bearings have not been fitted, are provided with grease nipples. These should be greased at *monthly* intervals with Wadkin L6 grease.

There is no requirement for periodic lubrication of the feed rolls motor driven variable speed unit.

### Weekly

Grease the machine slideways and the various traverse screws with Wadkin Grade L6 grease (see **Approved Lubricants**).

### Belt Drive Tensioning (Fig 1)

Check drive belts at regular intervals (as indicated below). If the need arises retension. Insufficient tension causes slipping and premature belt wear. Too much tension causes bearing wear. Tension as indicated in Checking/Adjustment.

Observe the operation of the machine when first put into service. After approximately one hours effective use, check and retension belts to take up initial belt stretch.

Generally drive belts will require adjustment at intervals to take up any slack due to use. *Three-monthly* intervals are recommended as an initial guide.

It is important to check the condition and tension of the cutterspindle drive belts at more frequent intervals, depending on conditions of use, if problems relating to quality of finish are to be avoided. *Monthly* intervals are recommended initially.

Checking/Adjustment is carried out as follows:

- (1) Remove the drive cover (1).
- (2) Check belt tension. The belt should be taut.
- (3) To adjust slacken off the motor securing bolts (2) so that the motor's weight is on the belt.

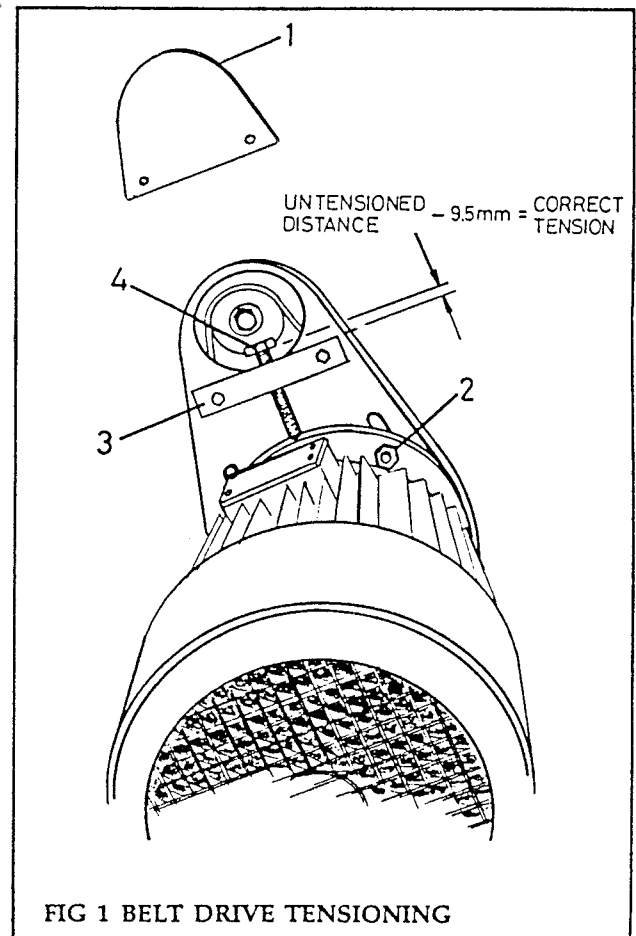

Fit the screw block (3) using the drive cover mounting holes as the fixing position.

Adjust the tensioning screw (4) until the bottom of the screw is just touching the motor flange.

Turn the tensioning screw (4) such that the distance between the tensioning screw head and the top of the screw block (3) decreases by 9.5mm.

Tighten the motor mounting bolts (2).  
Slacken off the tensioning screw (4) and remove screw block.

(4) Refit drive cover.

### Cleaning

Woodworking machines are designed to need a minimum of maintenance. However, a certain level of maintenance, especially cleaning and lubrication, will pay dividends in quality of work.

It is recommended that the machine be cleaned thoroughly once a week, especially when working on hardwood such as Sipo (Ufile) or highly resinous material, to prevent choking of ventilator airways and build up of deposits on working parts.

Clean all spindles regularly and remove all remains of resin and grease. Do the same with cutterblock collars and machine tables (bed-plates) and lightly lubricate. Check that all machine parts slide, or rotate freely. Lubricate as indicated in the lubricating instructions (see **Maintenance**).

If cleaning with compressed air, take care not to direct the jet onto the spindle bearing housings, moving shafts, etc., to avoid forcing dust and debris into bearings and housings.

Adjust the variable speed drive unit through the full range once a week to avoid the feed drive mechanism jamming.

## 4:2 UNSCHEDULED MAINTENANCE

Unscheduled maintenance consists of replacing or correcting items which are worn, damaged, or are otherwise unserviceable. Generally items which are defective must be replaced.

These tasks require specialised knowledge and tools to perform. Following this type of maintenance, the machine will need to be set up prior to return to work.

All unscheduled tasks — such as changing bearings, should be performed by competent personnel.

### Changing Cutterblock Spindle Bearings (Fig 1)

The bearings (5) have been fitted to the cutterblock spindles (6) in an orthodox manner. At the non-drive end of the spindle a liquid engineering adhesive ('Loctite' grade 241) has been applied to the internal thread diameter of the bearing nut (4).

**NOTE:** This nut can be right or left-hand thread, dependant upon spindle rotation and tightens against the direction of rotation.

To dis-assemble parts joined by 'Loctite' adhesive use normal tools and methods. If the holding force of the 'Loctite' joint is too great then apply gentle heat and break the bond while the parts are still hot. The bonding adhesive may be left as a powder and must be removed before applying further adhesive.

### Preparation Prior to Fitting Bearings

Before fitting a new bearing, the protective lubricant must be meticulously removed with petroleum spirit, triethanolamine, or other volatile solvent.

In order to prevent the moving parts from being damaged by drying out due to over cleaning, add a small amount of the bearing lubricant to the cleaning agent at the second bath. The film of grease which remains after the solvent has evaporated will provide protection for the bearing until charged with lubricant.

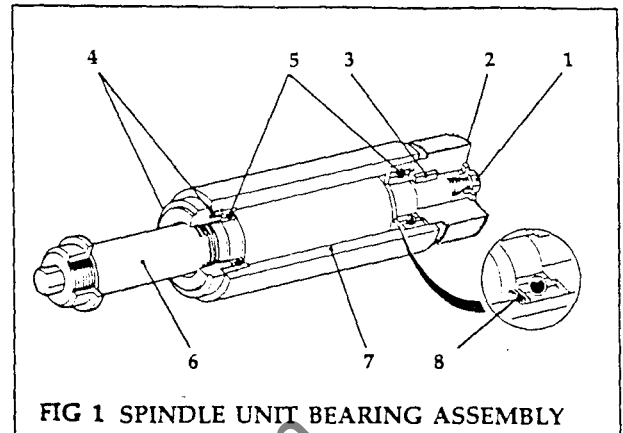

FIG 1 SPINDLE UNIT BEARING ASSEMBLY

The new bearings should be charged with 'Kluber' lubricant, type 'Isoflex' NBU 15. It is important that the correct amount of grease is applied, preferably using the formula:

$$G \text{ (weight in grams)} = d \times B \times 0.01$$

where;  $d$  = bore of bearing in mm  
 $B$  = width in mm

This is approximately sufficient to fill one third of the bearing volume.

To remove the bearings:

- (1) Remove pulley assembly from spindle by unscrewing the M12 hexagon screw (1). Withdraw pulley (2) and remove parallel key (3) from spindle.
- (2) Remove bearing nuts (4). Remove existing bearings (5), using a bearing puller on the bearing rings. Take care not to damage the spindle or housing.
- (3) After Preparation; fit new bearings (5) to spindle (6) and housing (7), include spring discs (8) as previously fitted. Use only sufficient pressure to fit bearings, applying pressure to the inner ring only. Ensure that bearing ring fits up to location shoulder on the spindle.
- (4) Reassemble spindle unit, lubricate bearing (see Preparation). Fit bearing nuts (4). Tighten nuts until assembly is secure. Do not over tighten.
- (5) Check that spindle assembly runs freely and without end float.

- (6) Refit parallel key (3), pulley and M12 hexagon securing screw. Tighten screw to spindle until the assembly is secure.

### Replacing Drive Belts

- (1) Remove drive guard covers front and rear (1).
- (2) Slacken off the motor securing bolts (2), slightly lift the motor to release any tension on the belt and then re-tighten.
- (3) The banjo (3) and the motor (4) must be removed as one unit to replace belts.

The banjo is secured by four bolts, two at the top clamping the banjo to the spindle and two lower down. With the bolts removed and the weight of the unit supported slide the unit off the spindle.

- (4) Remove old belt and fit a new one of the same size and type as the old one (see **Motor Drive Belt Data**).

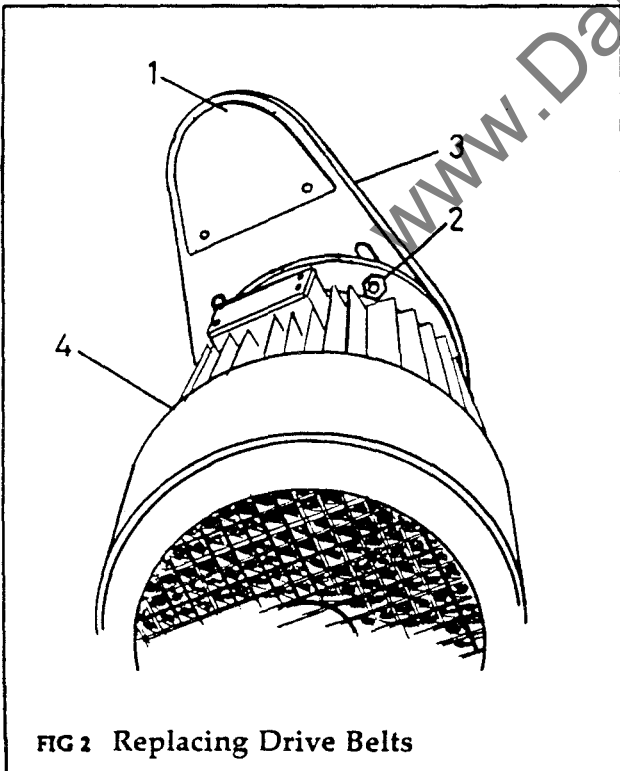

FIG 2 Replacing Drive Belts

- (5) Slide the unit back onto the spindle whilst holding the belt clear of the spindle pulley at the top and in position on the lower motor pulley.

Replace bolts and tighten.

- (6) Tension the belt (see **4:1 Belt Drive Tensioning**).

### Variable Speed Drive Pulleys (Fig 3)

The variable speed pulleys incorporated within the feed roll drive unit are virtually maintenance free.

The drive arrangement employs the 'Simplabelt' drive unit. The method of power takeoff for the unit is via a gearbox for shaft drive.

Should it be necessary to repair the feed drive, or fit a new drive belt, proceed as follows:

#### To Dismantle

##### A. General

- (1) Adjust the drive unit to the maximum output speed before dismantling. Switch off drive.
- (2) Unscrew socket head capscrews (1) and remove the complete adjustment device (4).

##### B. Removing wide section drive belt

- (1) Unscrew socket head capscrews (15) and support the motor (3).
- (2) Separate cover (7) and connecting casting (2) so that the belt (10) can be removed from the variable speed pulley (13).
- (3) Remove belt (10) from the variable speed pulley (9).

##### C. Dismantling variable speed pulleys, motor and housing

- (i) Mechanically adjustable variable speed pulley (motor shaft)

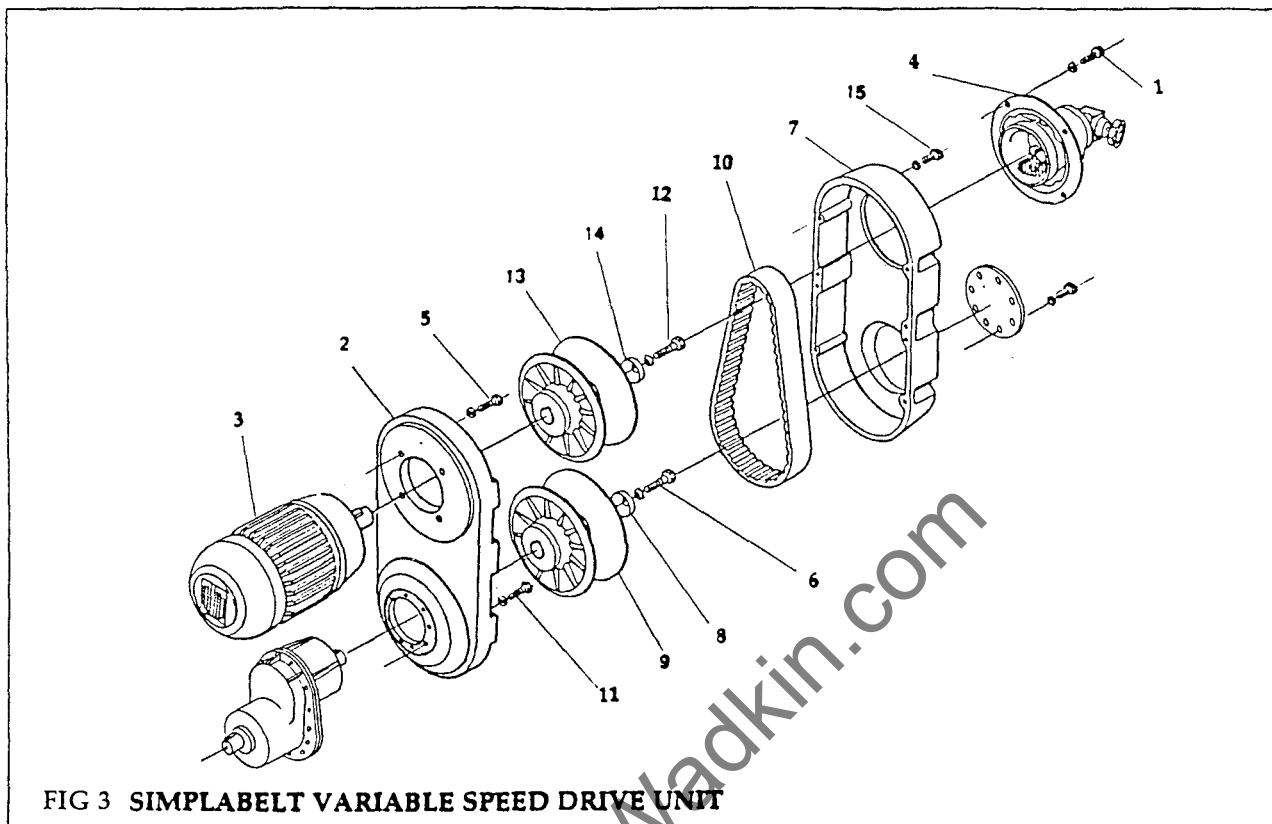

**FIG 3 SIMPLABELT VARIABLE SPEED DRIVE UNIT**

- (1) Unscrew axial tightening screw (12) and remove end cap (14).
- (2) Position a suitable extractor behind the circlip of the pulley and with an extractor, remove pulley (13) from the motor shaft.
  - (ii) Spring loaded variable speed pulley (gearbox shaft)
- (1) Unscrew axial tightening screw (6) and remove cap (8).
- (2) Remove the spring and spring retaining cap with a suitable extractor. Then using an extractor (gripping behind the hub flange) remove the pulley (9) from the gearbox shaft.
  - (iii) Motor and housing
- (1) Unscrew hexagon head screws (5) and remove motor.
- (2) Unscrew hexagon head screws (11) and remove housing from gearbox.

**To Assemble**

The assemble procedure is the reverse sequence to dismantle. ie: steps C, B, A.

- (1) When refitting the wide section drive belt; first place belt onto the fully opened mechanical variable speed pulley (13), then over the rim of the spring loaded variable speed pulley (9).

**NOTE:** Only original 'Simplabelt' wide section drive belts must be used.

**Feed Roll Drives and Gearboxes (Fig 4).**

The GD woodworking machine is fitted with shaft drives; having a solid shaft drive to gearboxes mounted on the beam, with cardan shaft drives to the feed rolls. The power transfer to each feedroll is via a right-angle worm and wheel gearbox at each offtake.

NOTE: GEARBOXES ARE ALWAYS FITTED IN THE ORDER SHOWN

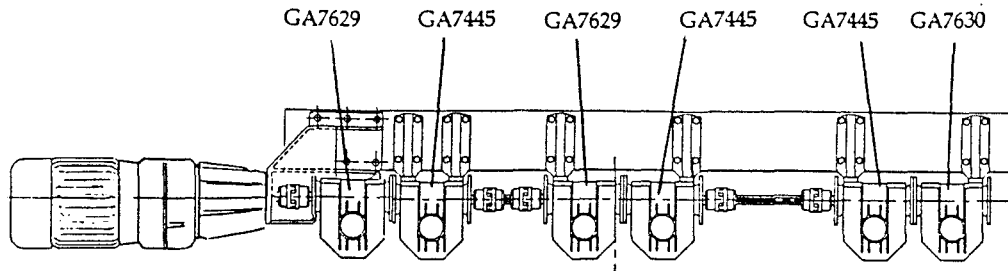

ARRT.1 LONG INFEED TABLE WITH SECOND BOTTOM HEAD

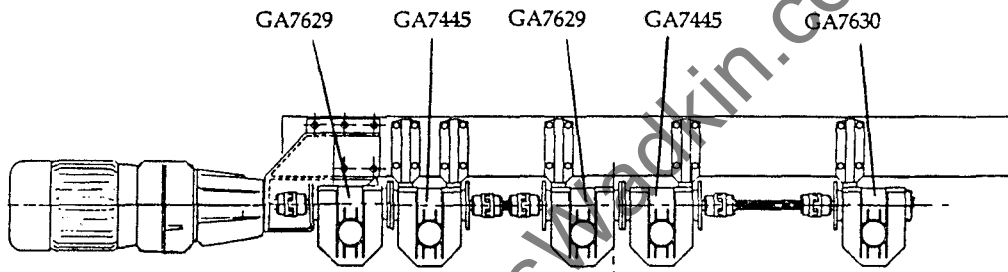

ARRT.2 LONG INFEED TABLE WITHOUT SECOND BOTTOM HEAD

FIG. 4 FEED ROLL DRIVES AND GEARBOXES

**IMPORTANT NOTE:** It is important to note that although all the gearboxes look the same externally, there are fundamental differences internally, depending on location. The various gearbox arrangements on the GD machine are shown in Fig 4.

When replacing any gearbox, it is important to note the location and Reference No. (GA....) which is shown on a plate attached to the gearbox housing, otherwise the bearing arrangements may not be suitable for the work load.

For reference; gearbox GA 7629 is always located adjacent to the drive unit. This gearbox has a taper roller bearing fitted on the input end of the worm drive shaft in place of a radial bearing to carry the extra loading imposed. The worm shaft, which is solid with parallel keys at both ends, extends through the gearbox to locate with a mating coupling to gearbox GA 7445.

The intermediate gearboxes GA 7445, are also fitted with extended worm drive shafts. The end which extends through the gearbox is hollow with internal keyway to permit coupling via a flange to a further gearbox in-line. A thrust bearing is fitted to this end of the shaft to accommodate the axial load.

The end of line gearbox GA 7630, is a standard type gearbox with radial bearings. The worm shaft does not extend through the box.

Each gearbox and the helical gearbox fitted to the variable speed control power take-off are filled with lubricant on assembly and 'sealed for life'.

The cardan shafts should be lubricated at *Monthly* intervals using Wadkin Grade L6 grease.

No other maintenance will normally be required on the shaft drive.

### 4: 3 FAULT FINDING

#### Mechanical Faults

Apart from mechanical failure (breakage) the majority of mechanical faults can be attributed to incorrectly tensioned drive chains or belts; the setting of cutterblocks and cutterblades; items working loose due to vibration — failure to set or tighten correctly; wrong speed setting; or misuse.

Therefore to get the best performance it is essential that the machine is set-up and used correctly, when many mechanical faults can be avoided.

#### Electrical Faults

**FAULT** The machine does not run when any 'START' button is operated

##### Diagnosis

- a. Disconnect (isolator) switch has not been closed
- b. Main fuse or control circuit fuse has blown
- c. Overload relay has tripped

##### Remedial Action

- a. Check and close if needed
- b. Replace fuse
- c. Reset relay. Check reason for trip

**FAULT** A motor does not start — loud humming sound

##### Diagnosis

- a. An open circuit in at least two 'line leads' of the motor
- b. The fuses of the motor have blown

##### Remedial Action

- a. Check circuit and rectify
- b. Replace fuse

**FAULT** An air break magnetic contactor does not operate

##### Diagnosis

- a. The contacts are burned and make improper contact
- b. Broken connection wire
- c. An overload relay has tripped
- d. A fuse has blown

##### Remedial Action

- a. Clean or replace contacts
- b. Remake connections
- c. Reset relay. Check reason for overload
- d. Replace fuse

#### Elimination of Vibration

It is important to check condition and tension of the cutter spindle drive belts regularly (see **Scheduled Maintenance**).

It is also important that the cutters are evenly ground and set to run true in the cutterblock, the assembled cutterblock should be statically balanced before fitting to the spindle.

In the case of high speed machines it is highly recommended that cutterblocks be dynamically balanced (see **Maintenance: Cutters and Toolholders**).

**FAULT** A Star/Delta connected motor does not operate when the contactor is connected in star

**Remedial Action**

Check/Remedy the symptoms outlined in paragraph above

**FAULT** When a motor is started, the fuses blow and the overload relay trips

**Diagnosis**

- a. The motor does not run freely
- b. There is a short circuit in the wiring mains
- c. The motor windings or winding are/is earthed

**Remedial Action**

- a. Check that the motor is free running
- b. Check the circuit wiring
- c. Check the windings in turn for electrical continuity and also earth faults with a 'Megger'

**FAULT** The motor overheats when running 'light' (unloaded)

**Diagnosis**

- a. The motor windings are connected in delta instead of star
- b. The mains voltage is too high
- c. The ventilating air ducts of the motor frame have become blocked with dust or chips, the cooling air passage has become impeded, or the cooling fan (if fitted) is not functioning correctly

**Remedial Action**

- a. Check connections
- b. Check mains voltage and correct
- c. Clean airways. Check fan operation

**FAULT** Motor overheats while working

**Diagnosis**

- a. The motor is overloading
- b. The motor is running under single phase conditions

**Remedial Action**

- a. Check reason and correct
- b. Check electrical circuits

**FAULT** The motor makes an abnormal noise

**Diagnosis**

- a. The cause can be of a mechanical or electrical nature
- b. If the noise is caused by an electrical fault, the noise will disappear when power is switched off
- c. If the noise is caused by a mechanical fault, the noise will diminish as speed of rotation decreases

**Remedial Action**

- a. Establish mechanical or electrical origin
- b.c. Check symptoms. Deduce by elimination to locate position and nature of fault





**FAULT** If the limit switch between the Top Head and Beam is operated simultaneously with either of the two Beam Vertical Traverse limit switches, the Beam will not lower

**Diagnosis**

Disengage the clutch on top head and manually wind down the top head until limit switch is released, then bring beam down by normal procedure (pushbutton control)

The foregoing observations are of a general nature and intended to be of assistance to avoid the incidence of breakdown. They do not preclude the user from calling a qualified electrician. In the case of an electrical fault or breakdown, in the interest of personal safety, it is always advisable to call a qualified electrician if the fault repeats.

## TABLES

### APPROVED LUBRICANTS

WADKIN	CASTROL	B.P.	SHELL	MOBIL	ESSO	GULF	CALTEX
L1	HYPIN AWS 32	ENERGOL HLP 32	VITROL 32	DTE OIL LIGHT 24	NUTO 44 OR ESSTIC H44	HARMONY 43 AW	RANDO OIL HDA
L2	ALPHA ZN 150	ENERGOL HP 150 OR CS 150	VITREA 150	VACTRA EXTRA HEAVY	ESSTIC 65	SERVICE 13	URSA P40
L4	MAGNA 68	ENERGOL HP 68 OR CS 68	VITREA 68	VACTRAL OIL HEAVY MEDIUM	ESSTIC 50	SERVICE 51	URSA P20
L6	SPHEEROL AP 3	ENERGREASE LS3	ALVANIA GREASE NO. 3	MOBILPLEX GREASE NO. 48	BEACON 3	GULFCROWN GREASE NO. 3	REGAL STARTAK PREMIUM 3

- L1 OIL Hydraulic oil with anti-corrosion, anti-oxidation, anti-wear, anti-foam performance.
- L2 OIL Gear oil (Viscosity 150 centi-strokes at 40°C).
- L4 OIL Plain mineral oil (Viscosity 68 centi-strokes at 40°C).
- L6 GREASE Grease NLG1 No. 3 consistency Lithium bearing grease.

**FAULT The Air Break Magnetic Starter is noisy****Diagnosis**

- a. The mains voltage is too low
- b. The surfaces of the 'fixed' and 'moving' contacts are dirty

**Remedial Action**

- a. Check mains voltage and correct
- b. Clean or replace contacts

**FAULT The air break magnetic starter remains 'closed' after a STOP button has been operated****Diagnosis**

- a. The contactor 'fixed' and 'moving' contacts have welded together following a short circuit

**Remedial Action**

- a. Check and remove cause of the short circuit. Replace the damaged contacts. It may be necessary to replace the complete contactor if too damaged

**FAULT A fault condition arises on a motor and the overload current relay fails to operate.****Diagnosis**

- a. The overload relay may be incorrectly rated – it should correspond to the normal full load current of the motor (given on the motor nameplate) for Direct-on-Line starting
- b. If the overload relay is connected in a Star/Delta starter, the rating of the overload should be the normal full load current of the motor (given on the motor nameplate) multiplied by 1/1.73 (0.58)

**Remedial Action**

- a. Replace with correctly rated relay

**FAULT A Spindle stops, but the motor still runs****Diagnosis**

- a. The drive belts are loose, broken, or have come off

**Remedial Action**

- a. Retension or replace belts

**FAULT The Rise and Fall drive motor does not operate****Diagnosis**

- a. The limit switch on the top horizontal head, or the limit switch at the end of the machine is jammed by wood chips or is damaged
- b. The push button is faulty

**Remedial Action**

- a. Check and clean the limit switches
- b. Check and clean the push button

**4:4 MOTOR AND DRIVE BELT DATA**

Belts and pulleys for spindle drive to <b>FIRST AND SECOND BOTTOM HEADS</b> Frequency 50 Hertz								
Motor			Motor Pulley	Belts			Spindle Pulley	Spindle Speed
Frame Size	K.W.	HP	Wadkin Ref.	Stephens Ref.Ref.	Wadkin Ref.	Qty	Wadkin Ref.	R.P.M
D132	5.5	7.5	GA 1850	871x55GT10	K3005491	1	GA 1815	6000
D112	5.5	7.5	GA 1849	871x55GT10	K3005491	1	GA 1815	6000

Belts and pulleys for spindle drive to <b>FIRST AND SECOND BOTTOM HEADS</b> Frequency 60 Hertz								
Motor			Motor Pulley	Belts			Spindle Pulley	Spindle Speed
Frame Size	K.W.	HP	Wadkin Ref.	Stephens Ref.Ref.	Wadkin Ref.	Qty	Wadkin Ref.	R.P.M
D132	5.5	7.5	GA 1852	817x55GT10	K3005492	1	GA 1815	6000
D112	5.5	7.5	GA 1851	817x55GT10	K3005492	1	GA 1815	6000

Belts and pulleys for spindle drive to <b>FENCE SIDE HEAD</b> Frequency 50 Hertz								
Motor			Motor Pulley	Belts			Spindle Pulley	Spindle Speed
Frame Size	K.W.	HP	Wadkin Ref.	Stephens Ref.Ref.	Wadkin Ref.	Qty	Wadkin Ref.	R.P.M
D112	4.0	5.5	GA 1849	871x55GT10	K3005491	1	GA 1815	6000

Belts and pulleys for spindle drive to <b>FENCE SIDE HEAD</b> Frequency 60 Hertz								
Motor			Motor Pulley	Belts			Spindle Pulley	Spindle Speed
Frame Size	K.W.	HP	Wadkin Ref.	Stephens Ref.Ref.	Wadkin Ref.	Qty	Wadkin Ref.	R.P.M
D112	4.0	5.5	GA 1851	817x55GT10	K3005492	1	GA 1815	6000



Belts and pulleys for spindle drive to								
NEAR SIDE HEAD					Frequency 50 Hertz			
Motor			Motor Pulley	Belts			Spindle Pulley	Spindle Speed
Frame Size	K.W.	HP	Wadkin Ref.	Stephens Ref.Ref.	Wadkin Ref.	Qty	Wadkin Ref.	R.P.M
D112	5.5	7.5	GA 1849	871x55GT10	K3005491	1	GA 1815	6000

Belts and pulleys for spindle drive to								
NEAR SIDE HEAD					Frequency 60 Hertz			
Motor			Motor Pulley	Belts			Spindle Pulley	Spindle Speed
Frame Size	K.W.	HP	Wadkin Ref.	Stephens Ref.Ref.	Wadkin Ref.	Qty	Wadkin Ref.	R.P.M
D112	5.5	7.5	GA 1851	817x55GT10	K3005492	1	GA 1815	6000

Belts and pulleys for spindle drive to								
TOP HEAD					Frequency 50 Hertz			
Motor			Motor Pulley	Belts			Spindle Pulley	Spindle Speed
Frame Size	K.W.	HP	Wadkin Ref.	Stephens Ref.Ref.	Wadkin Ref.	Qty	Wadkin Ref.	R.P.M
D132	7.5	10.0	GA 1850	871x55GT10	K3005491	1	GA 1815	6000

Belts and pulleys for spindle drive to								
TOP HEAD					Frequency 60 Hertz			
Motor			Motor Pulley	Belts			Spindle Pulley	Spindle Speed
Frame Size	K.W.	HP	Wadkin Ref.	Stephens Ref.Ref.	Wadkin Ref.	Qty	Wadkin Ref.	R.P.M
D132	7.5	10.0	GA 1852	871x55GT10	K3005492	1	GA 1815	6000

---

## SECTION 5 ILLUSTRATED PARTS LIST

### CONTENTS

- 1 Bedplate Charts
- 2 Bottom Heads
- 3 Fence and Near Side Head Carriage Unit Adjusting Mechanism
- 4 Top Head - including Power Rise and Fall
- 5 Bottom (excluding first) and Top Heads axial adjustment
- 6 Top Head Chipbreaker Pressure Pad and Extraction Hood
- 7 Near Side Head Chipbreaker and Extraction Hood
- 8 Side Guides and Guards - Standard Machine
- 9 Variable Speed Drive Unit
- 10 All Spindle Units
- 11 Mounting for Top Pad Pressure Unit before Top Head
- 12 Top Roller Pressure Unit
- 13 Single Side Roller Pressure Unit
- 14 Fences
- 15 Beam Power Rise and Fall
- 16 Shaft Drives and Gearboxes
- 17 Top Head Radial Chipbreaker Pressure Pad and Extraction Hood
- 18 Fences - Standard Machine
- 19 Flange Mounted Feedrolls
- 20 Shaft Mounted Feedrolls

**IMPORTANT:** WHEN ORDERING SPARES ALWAYS QUOTE MODEL AND MACHINE NUMBER

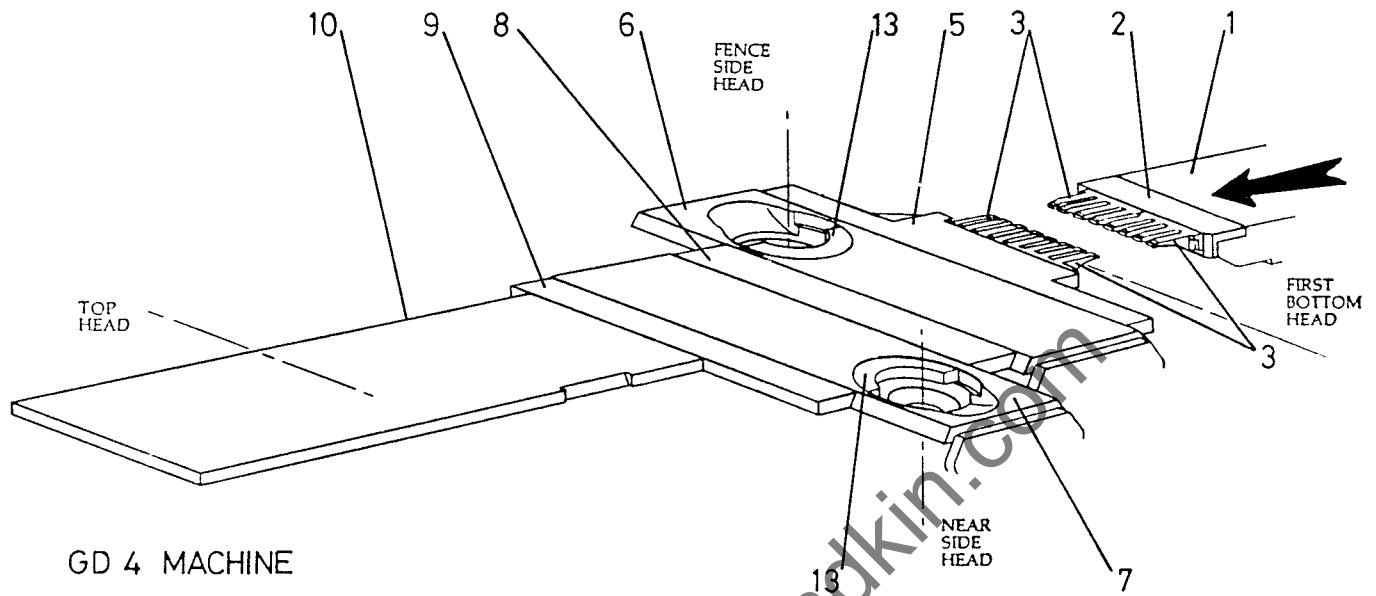

GD 4 MACHINE

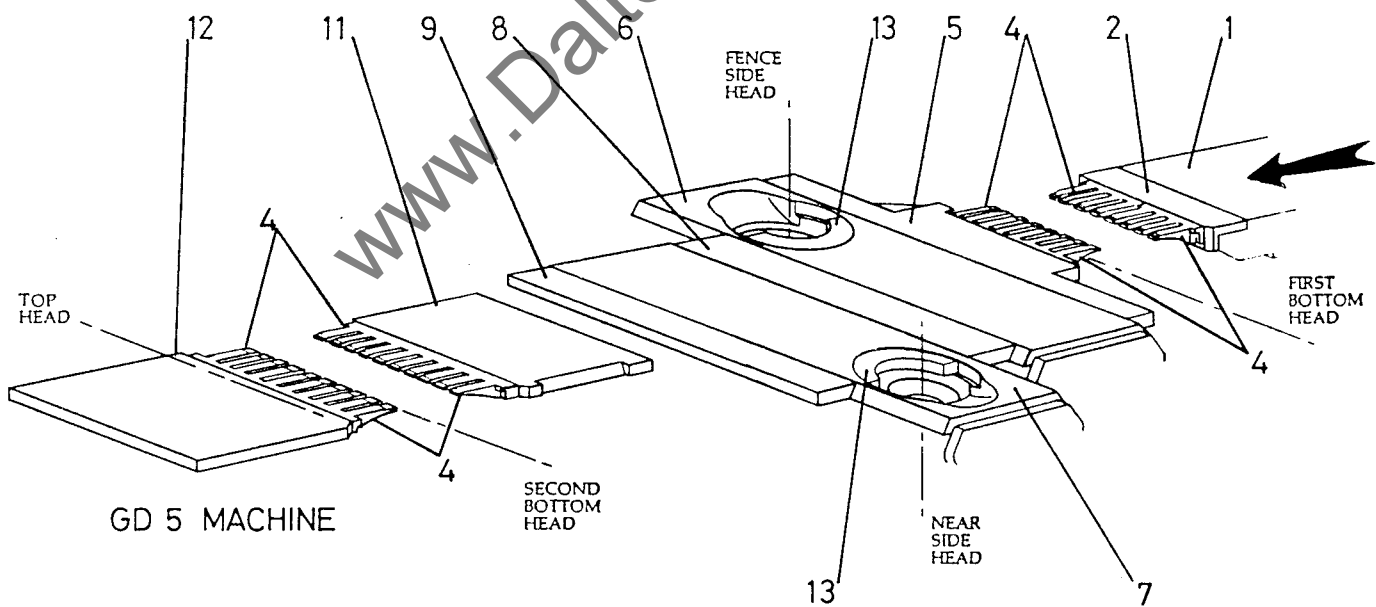

GD 5 MACHINE

FIG 1 BEDPLATES



1. BEDPLATES FOR STANDARD FOUR AND FIVE HEAD MACHINES

Ref. No.	Description	No. Off	
1	Infeed table	1	
2	Lip plate for infeed table	1	
3	Nose piece for bedplate (GD4)	4	
4	Nose piece for bedplate (GD5)	8	
5	Bedplate after 1st bottom head	1	
6	Fence side Carriage unit	} refer to section 5 Item 3	1
7	Near side carriage unit		1
8	Bedplate between near side & fence side head carriage	1	
9	Bedplate after near side head	1	
10	Bedplate under top head	1	
11	Bedplate before 2nd bottom head	1	
12	Bedplate after 2nd bottom head	1	
13	Fill-in ring	2	

www.DaltonsWadkin.com

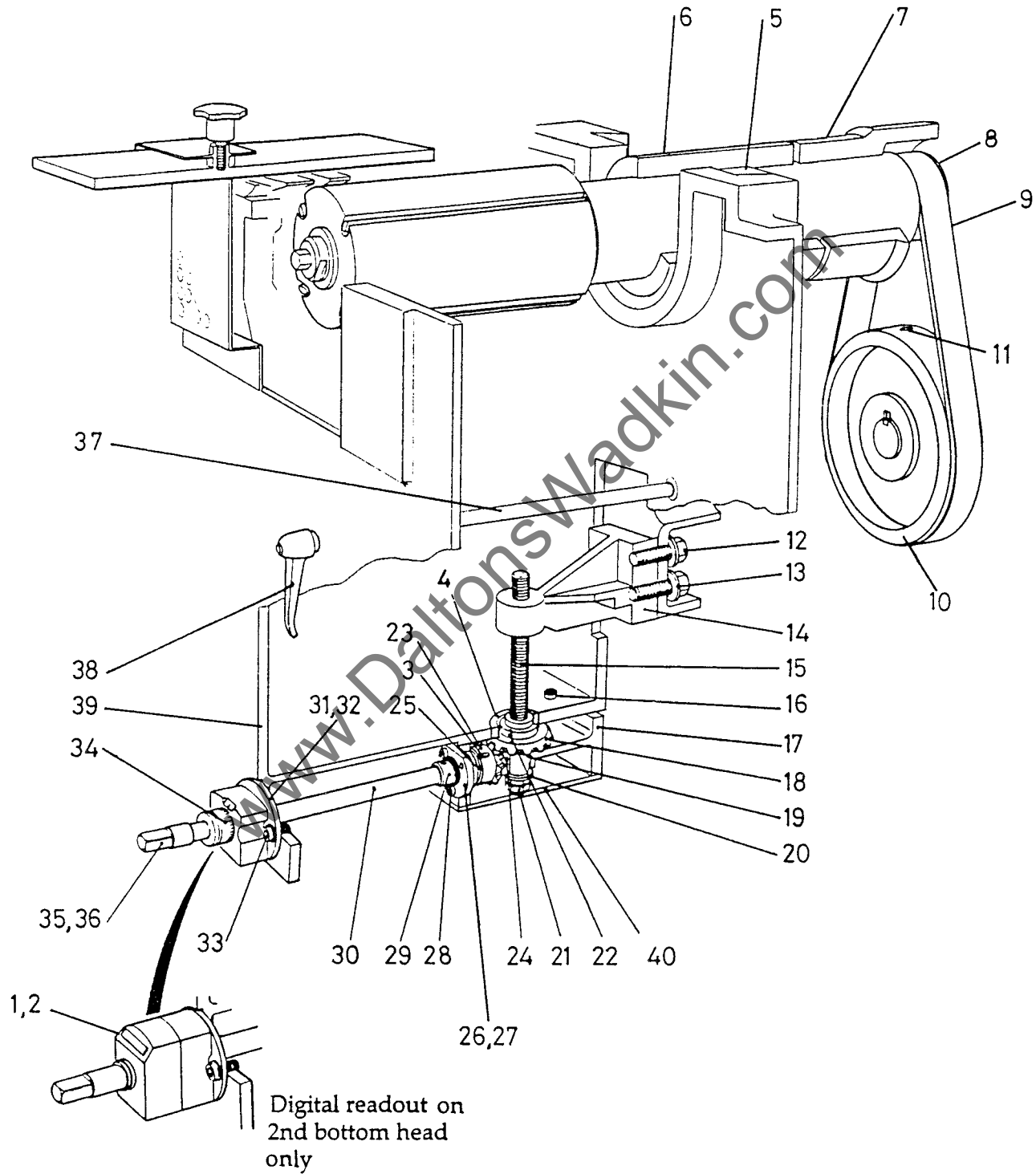

FIG 2. BOTTOM HEADS





## 2. BOTTOM HEADS

Ref. No.	Description	No. Off
1	Digital Readout	1
2	'0' Ring	1
3	Parallel Key 8mmx7mmx20mm long	1
4	Top Cover Bevel Gear	1
5	Slide Strip	1
6	Bottom Head Spindle Housing, vertical slide	1
7	Pulley Belt Housing, horizontal heads	1
8	Spindle Pulley	1
9	Stephen's Flat Belt ) See Motor and	1
10	Motor Pulley ) Drive Belt Data	1
11	Hexagon socket grubscrew M8x16mm long	1
12	Hexagon Head Screw, M10x30mm long	4
13	Spring Washer, 10mm diameter, single coil	4
14	Bracket nut, Bottom Head vertical adjustment	1
15	Vertical Adjustment Screw, First Bottom Head	1
16	Hexagon Socket Capscrews, M6x75mm long	4
17	Bevel Box, Bottom Head vertical adjustment	1
18	Bevel Gear Wheel	1
19	Bearing Washer, top and bottom	2
20	Thrust Washer	1
21	M16 Hexagonal Nut	2
22	Parallel key 5mmx5mmx20mm long	1
23	Bevel Gear Pinion	1
24	Circlip, 16mm external, pinion shaft (not shown)	1
25	Thrust Washer	1
26	Bronze Bush, 25mmIDx30mmODx25mm long	1
27	End Cap, bevel box	1
28	Hexagon socket capscrews, M6x20mm long	3
29	Collar	1
30	Extension shaft, bevel gear	1
31	Bearing bracket, extension shaft	1
32	Bronze Bush, 20mmIDx25mmODx25mm long	2
33	Hexagon Socket Capscrews, M6x20mm long	2
34	Digital Readout	1
35	Square End Shaft Extension	1
36	Taper Pin, No.1	1
37	Extension Shaft, Vertical Lock	1
38	Locking Handle, M12x25mm, male	1
39	Main Frame	1
40	Cover, Bevel Box	1

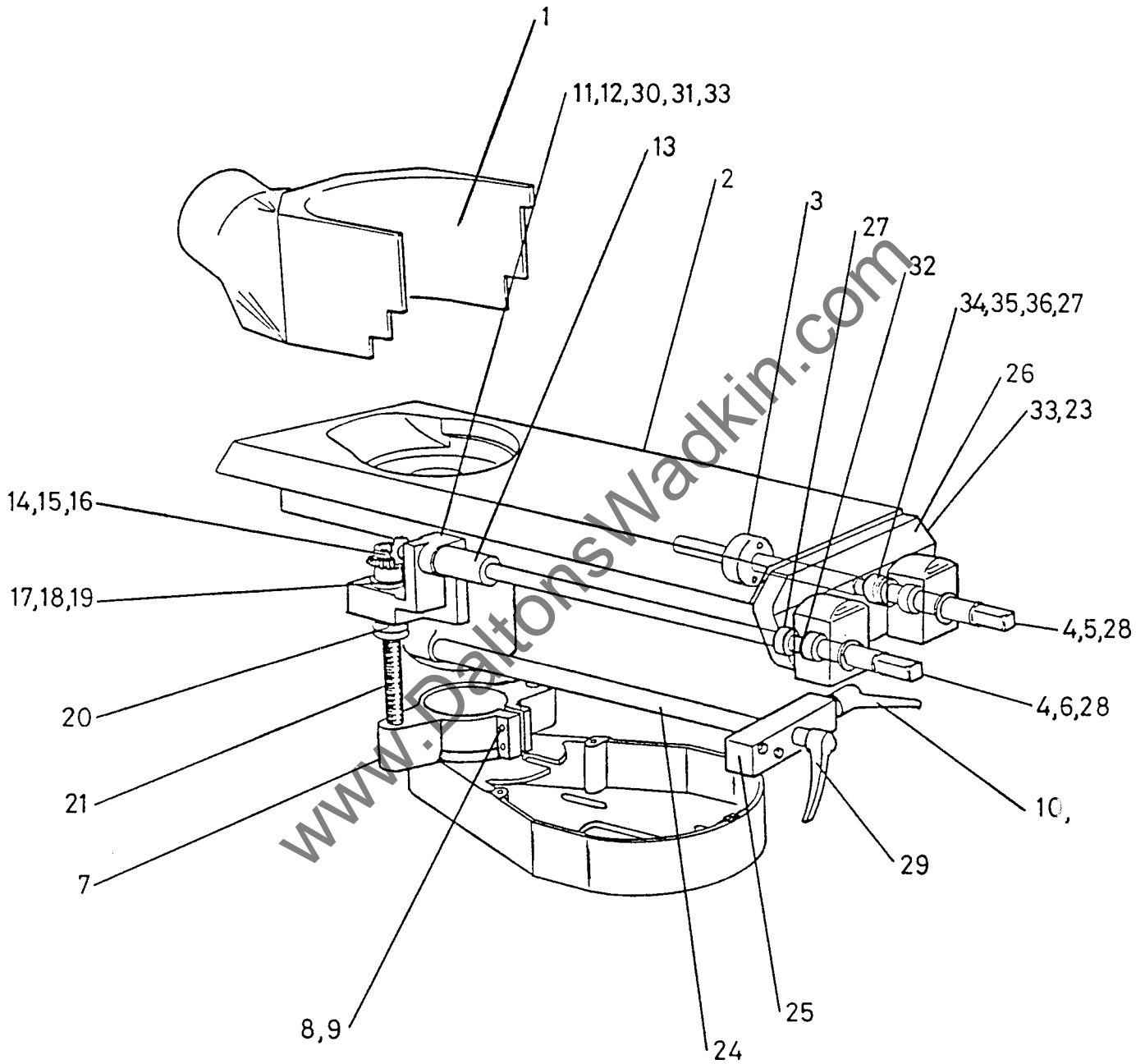

FIG 3 FENCE AND NEAR SIDE HEAD CARRIAGE UNIT ADJUSTING MECHANISM

## 3. FENCE AND NEAR SIDE HEAD CARRIAGE UNIT ADJUSTING MECHANISM

Ref. No.	Description	No. Off
1	Exhaust Hood (Fence Side illustrated)	1
2	Fence or Near Side Head spindle carriage	1
3	Nut for lateral movement	1
4	Digital Readout	2
5	Horizontal Shaft for lateral movement	1
6	Front horizontal shaft for vertical movement	1
7	Belt/Pulley Housing for Vertical heads	1
8	Hexagon Cap Screw, M12 dia x 55mm long	2
9	Spring Washer, size M12	2
10	Locking Handle M10 x 25 male	1
11	Rear Horizontal Shaft for vertical movement	1
12	Mitre gear bracket for side head vertical adjustment	1
13	Collar for horizontal shaft for vertical adjustment	1
14	Straight mitre bevel gear (16T2.5MOD)	2
15	Hexagon socket screw-cup point, M6 x6mm long	2
16	M12, self-locking nut	1
17	'INA' Bearing AXK2542	2
18	'INA' Bearing AS2542	2
19	'INA' Bearing LS2542	2
20	Chamfered Notch Nut, M24x1.5	2
21	Vertical screw for sidehead vertical adjustment	1
22	Brass Pad dia 6 x 5 thick	1
23	Bearing Plate	1
24	Locking shaft for fence or near side spindle barrel	1
25	Clamping block for side head horizontal movement	1
26	Legend Plate	1
27	Collar, M20 dia	2
28	'O' Ring	2
29	Locking Handle, M12x25mm, male	1
30	Mitre Gear Bracket Guard	1
31	Key, 5x5x20	3
32	'INA' Thrust Washer AS2035	1
33	Grease Nipple	4
34	'INA' Bearing AXK2035	2
35	'INA' Thrust Washer AS2035	3
36	'INA' Shaft Washer WS81104	1

When ordering items please state whether near side or fence side carriage.

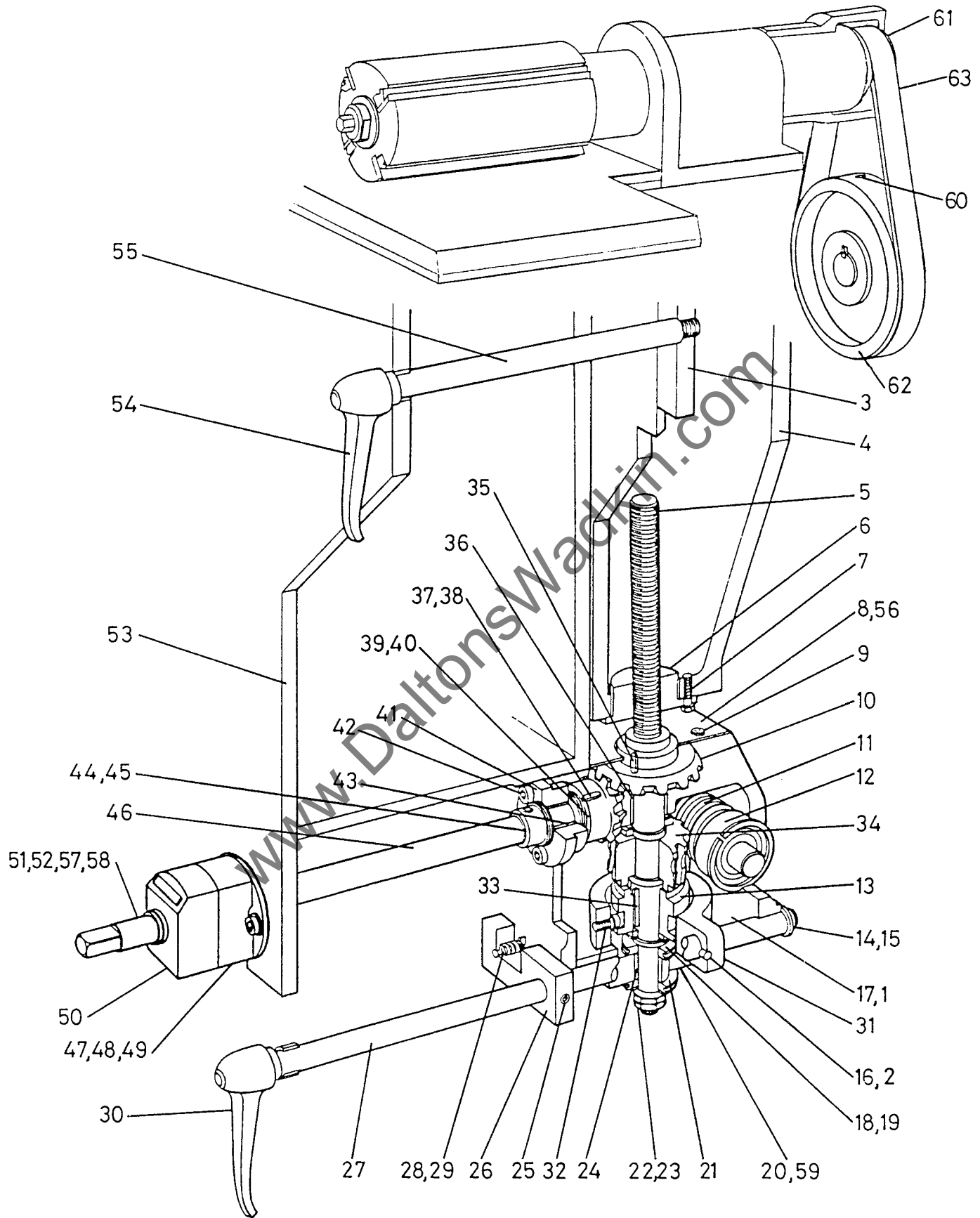

FIG 4 TOP HEAD INCLUDING POWER RISE AND FALL

4. TOP HEAD INCLUDING POWER RISE AND FALL

Ref. No.	Description	No. Off
1	Socket Head Cap Screw M12x30mm long	4
2	Hexagon Socket Grub Screw M12x30mm long	1
3	Slide Strip	1
4	Top Head Vertical Slide	1
5	Vertical Screw, Top Head Rise and Fall	1
6	Bracket nut, Top Head rise and fall	1
7	Hexagon Head Screw, M8x25mm long	2
8	Top Cover, gearbox/clutch housing	1
9	Socket Head Capscrews, M6x10mm long	4
10	Bevel Gear Wheel	1
11	Worm Gear, rise and fall top beam/head	1
12	Bearing, 6204RS	2
13	Dogclutch, Top Head rise and fall	1
14	Circlip, 16mm external	1
15	Spacer Washer	1
16	Tension Pin, 6mmx32mm long	1
17	Gearbox/Clutch Housing	1
18	Spacer Washer	2
19	Circlip, 30mm external	2
20	Bottom Cover, gearbox/clutch housing	1
21	Thrust Washer	2
22	Plain Washer, 16mm	1
23	M16 Hexagon Nut	2
24	Bronze Bush, 25mmIDx30mmODx20mm long	1
25	Hexagon Socket Screw, cup point, M6x10mm long	1
26	Clutch Location Arm	1
27	Clutch Shaft	1
28	Spring, clutch location arm lock	1
29	Steel Ball, 10mm diameter	1
30	Locking Handle, M10x25mm, male	1
31	Clutch Yoke, top head rise and fall	1
32	Hexagon Socket Capscrew, M6x10mm long	2
33	Parallel key, 8mmx7mmx32mm long	1
34	Worm Wheel, Top Head rise and fall	1
35	Parallel Key, 8mmx7mmx14mm long	1
36	Bronze Bush, 30mmIDx35mmODx20mm long	1
37	Circlip, 16mm external (not shown)	1
38	Parallel Key, 5mmx5mmx20mm long	1
39	Spacer Washer	2
40	Bevel Gear, pinion	1

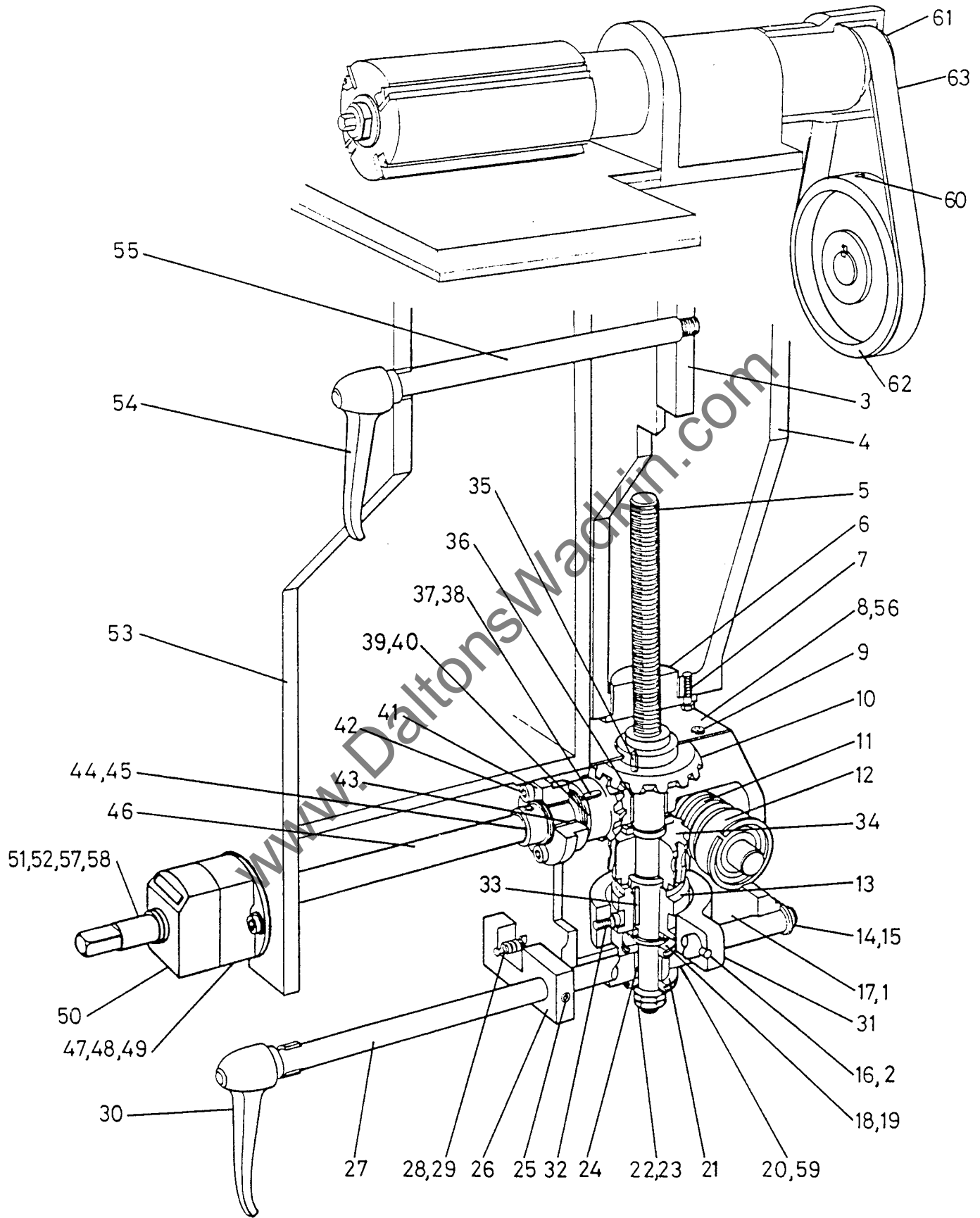

FIG 4 TOP HEAD INCLUDING POWER RISE AND FALL

4. TOP HEAD INCLUDING POWER RISE AND FALL (cont.)

Ref. No.	Description	No. Off
41	End Cap, Bevel Box	1
42	Socket Head Capscrew, M6x20mm long	3
43	Bronze Bush, 20mmIDx25mmODx25 long	1
44	Collar	1
45	Hex.Socket Screw - cup point, M6x6mm long	1
46	Extension Shaft	1
47	Bearing Bracket, extension shaft	1
48	Bronze Bush, 20mmIDx25mmODx25 long	1
49	Hex.Socket Capscrew, M6x20mm long	2
50	Digital Readout	1
51	Square End Shaft Extension	1
52	Taper Pin, No.1	1
53	Main Frame	1
54	Locking Handle	1
55	Extension Shaft, Vertical Lock	1
56	Hex.Head Screw, M12x30mm	4
57	Circlip ) Safety	1
58	Spring ) Feature	1
59	Securing Screw, M8x15mm hexagon socket	4
60	Hexagon Socket Grub Screw, M8x16mm long	1
61	Spindle Pulley ) See Motor	1
62	Motor Pulley ) and Drive	1
63	Stephen's Flat Belt ) Belt Data	1

www.DaltonsWadkin.com

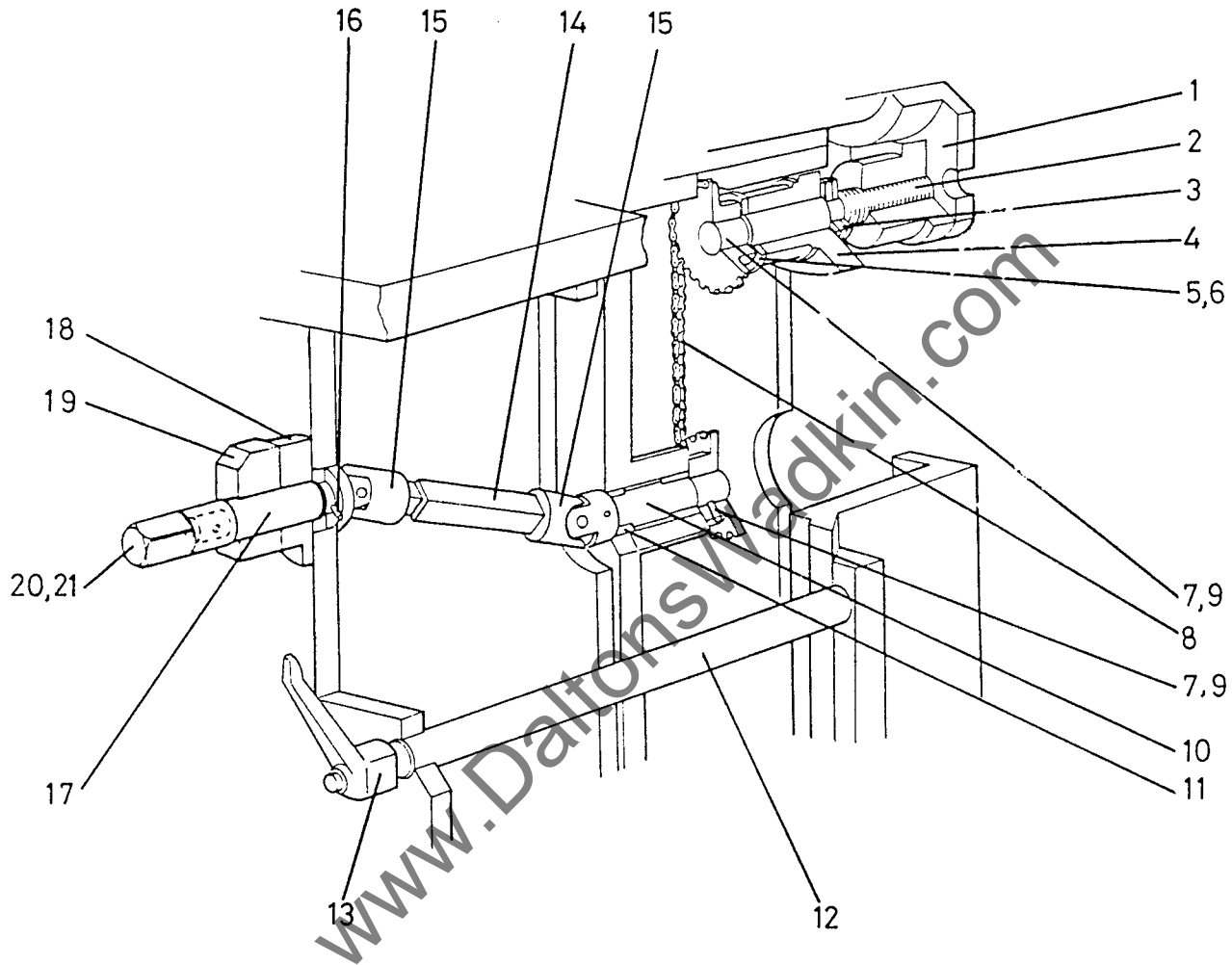

FIG 5 BOTTOM (EXCLUDING FIRST) AND TOP HEADS AXIAL ADJUSTMENT



## 5. BOTTOM (EXCLUDING FIRST) AND TOP HEADS AXIAL ADJUSTMENT

Ref. No.	Description	No. Off
1	Nut for horizontal head adjustment	1
2	Shaft for horizontal head adjustment	1
3	M24. × 1.5 chamfered notch nuts	2
4	Bearing bracket for horizontal adjustment	1
5	'INA' bearings AXK 2542	2
6	'INA' bearings AS 2542	4
7	Sprocket for horizontal head axial adjustment	2
8	'RENOLD' Roller chain No. 111046 12.9mm (1/2in.) pitch, 40 pitches including connecting link	1
9	No. 4. taper pin	2
10	Shaft	1
11	20mm. I.D. × 25mm. O.D. × 20mm. long bronze brush	2
12	Extension for vertical lock to horizontal heads	1
13	Locking handle M12. × 25mm. male	1
14	Universal coupling assembly for horizontal head adjustment	1
15	Universal coupling assembly for horizontal head cross adjustment	1
16	6mm. dia. × 32mm. long tension pin	1
17	Shaft for horizontal head cross adjustment	2
18	Bearing block	1
19	Digital readout (option)	1
20	Square shaft extension	1
21	Taper pin. No.1	1

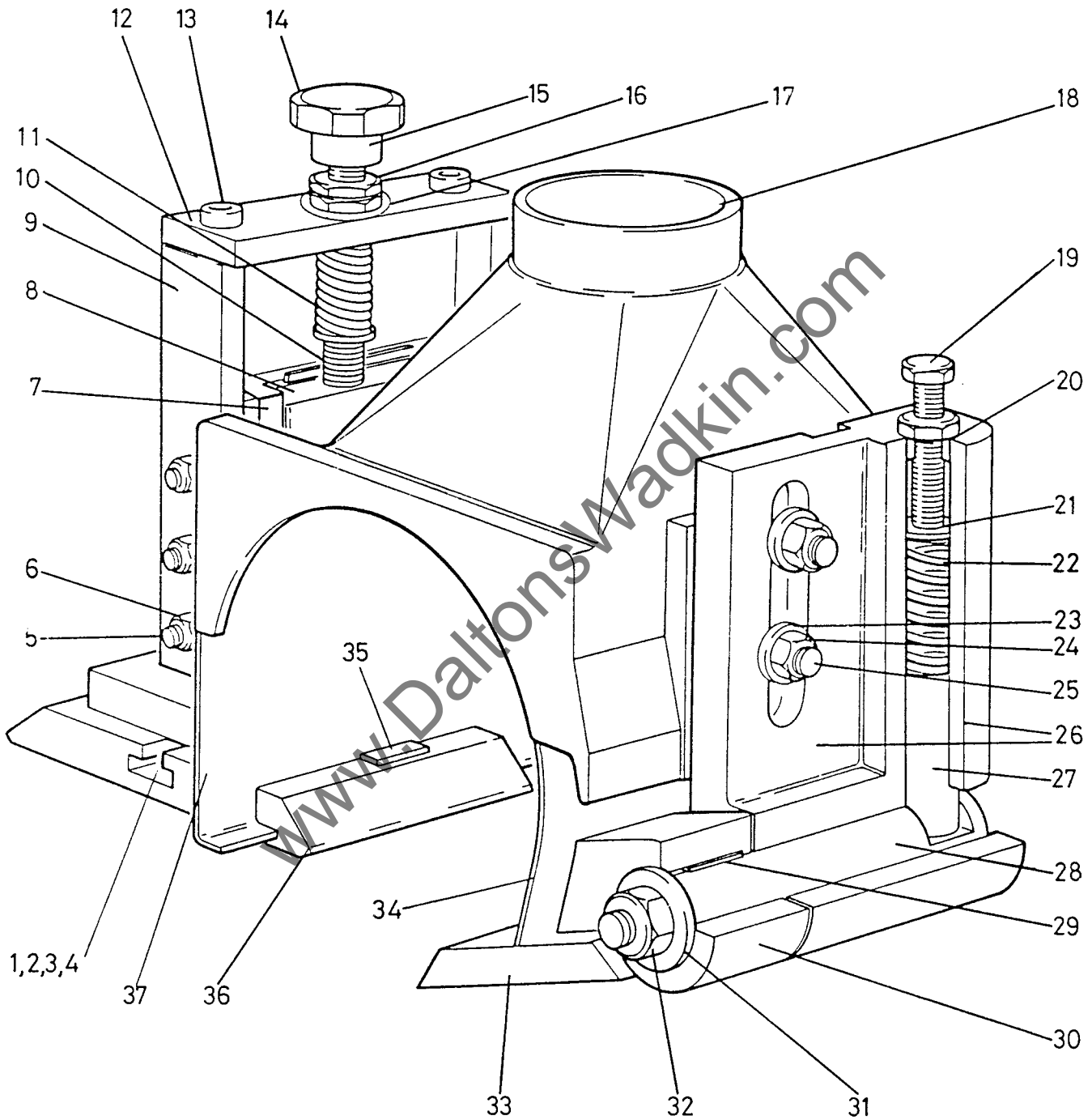

FIG 6 TOP HEAD CHIPBREAKER, PRESSURE PAD AND EXTRACTION HOOD

6. TOP HEAD CHIPBREAKER, PRESSURE PAD AND EXTRACTION HOOD

Ref. No.	Description	No. Off
1	Tee-nut, M10, ref. WDS 664 203	2
2	Screwed stud, M10 x 45mm long	2
3	Washer 10mm, bright mild steel	2
4	Hexagon nut, M10	2
5	Hexagon socket screws, half dog point, M6 x 35mm long	3
6	Hexagon nut, M6	3
7	Gib strip, rise and fall bracket, Top Head pressure pad	1
8	Slide, rise and fall, for shoe Top Head pressure pad	1
9	Bracket, rise and fall, Top Head pressure	1
10	Screw, raise/lower, Top head pressure pad	1
11	Compression spring, Top Head pressure pad	1
12	Top plate, Top Head pressure pad	1
13	Hexagon socket screw, M8 x 20mm long	2
14	Handwheel, M12 blind hole	1
15	Taper pin. No.0	1
16	Hexagon nut, thin, M12	2
17	Washer, 12mm, bright mild steel	1
18	Exhaust hood, Top Head	1
19	Hexagon head screw, M12 x 40mm long	1
20	Plug, spring loaded Top Head chipbreaker	1
21	Cap, Top Head chipbreaker spring	1
22	Spring, Top head chipbreaker	1
23	Washer, 10mm, bright mild steel	2
24	Hexagon nut, M10	2
25	Screwed stud, M10 x 50mm long	2
26	Pivot bracket, Top Head chipbreaker	1
27	Plunger, spring loaded Top Head chipbreaker	1
28	Pivot shaft, Top Head chipbreaker	1
29	Parallel key, 8mm x 6mm x 32mm long	1
30	Holder, Top Head chipbreaker shoe	1
31	Washer, chipbreaker pivot shaft	1
32	Nut, M12, self locking	1
33	Shoe, Top Head, 70mm long	1
	Shoe, Top Head, 82mm long	1
	Shoe, Top head, 105mm long	1
34	Chip deflector, Top Head chipbreaker	1
35	Cross tenon for shoe, top head pressure	1
36	Shoe, Top Head pressure	1
37	Cover, Top Head pressure pad	1

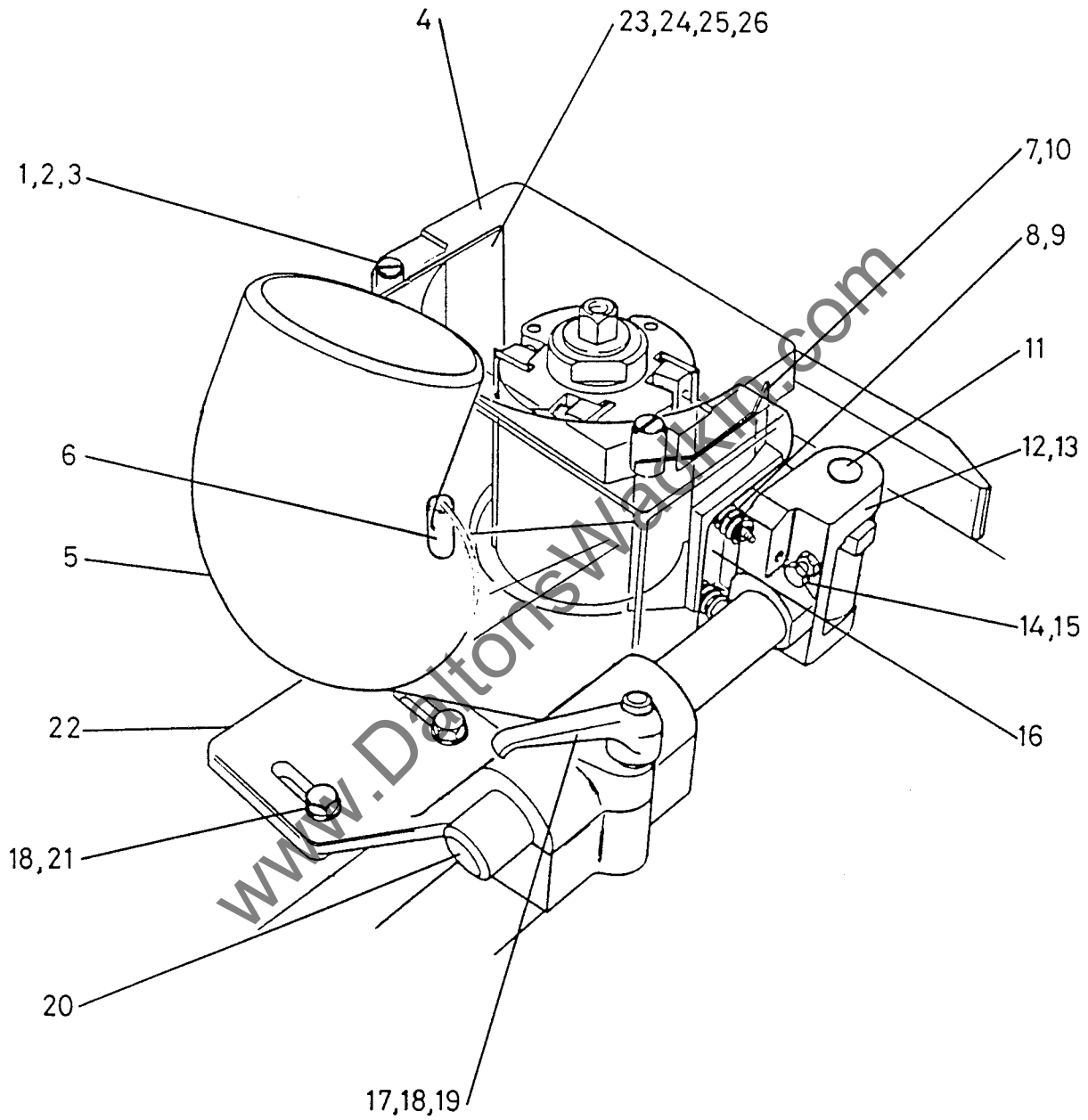

FIG 7 NEAR-SIDE HEAD CHIPBREAKER AND EXTRACTION HOOD

7. NEAR SIDE HEAD CHIPBREAKER AND EXTRACTION HOOD

Ref. No.	Description	No. Off
1	Spring clip	2
2	Shoulder pin, M16 dia.	2
3	Spacer, M20 dia.	2
4	Top cover for Near Side Head hood	1
5	Exhaust Hood for Near Side Head	1
6	Post	2
7	Near Side head chip deflector	1
8	Spring	2
9	Hexagon socket capscrew, M8 × 10mm	4
10+	Hexagon socket countersunk screw, M8 × 10mm	2
11	Pivot pin for Near Side head chipbreaker	1
12	Near Side head and chipbreaker shoe pivot bracket	1
13+	Cup point grub screw, M8 × 12mm	4
14	Hexagon full nut, M8	1
15	Hexagon head screw, M8 × 40mm	1
16	Near Side head chipbreaker shoe	1
17+	Screwed stud, 10mm × 60mm, M10	1
18	Washer, 10mm	3
19	Locking handle, M10 female	1
20	Adjusting bar for Near Side head chipbreaker	1
21	Hexagon head screw, M10 × 25mm	2
22	Shoe chipbreaker bracket	1
23+	Side Cover for Near Side Head Hood	1
24+	Screwed Stud, 6mm × 25mm, M6	2
25+	Washer, 6mm	2
26	Wing Nut M6	2
+	Not illustrated	

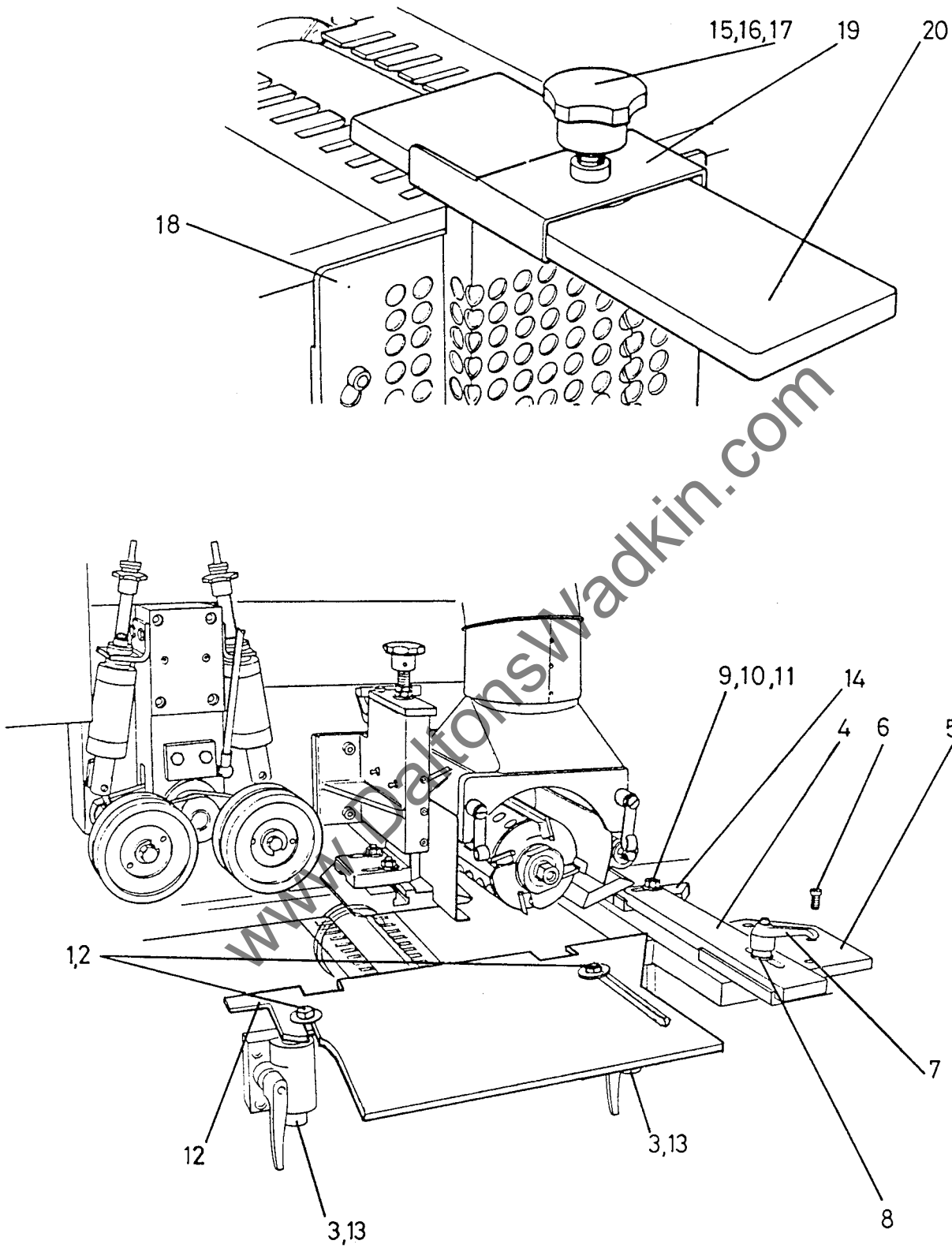

FIG 8 SIDE GUIDES AND GUARDS STANDARD MACHINE

## 8. SIDE GUIDES AND GUARDS STANDARD MACHINE

Ref. No.	Description	No. Off
1	Hexagon head screw M10 x 20mm long	2
2	Plain washer M10, bright mild steel	2
3	Support for front fence	2
4	Front guide support bar	1
5	Support plate for front guide	1
6	Hexagon socket cap screw M10 x 25mm long	3
7	Locking handle	1
8	Plain washer M12, bright mild steel	1
9	Screwed stud, M12 x 25mm long	1
10	Hexagon nut M12	1
11	Plain washer, M12 bright mild steel	1
12	Front fence	1
13	Support bracket	2
14	Front guide	1
15	Plastic handwheel (First bottom head only)	1
16	Locking screw (First bottom head only)	1
17	Locking pad (First bottom head only)	1
18	Side guard for second bottom head	1
19	Side guard for First bottom head	1
20	Top slide guard (First bottom head only)	1

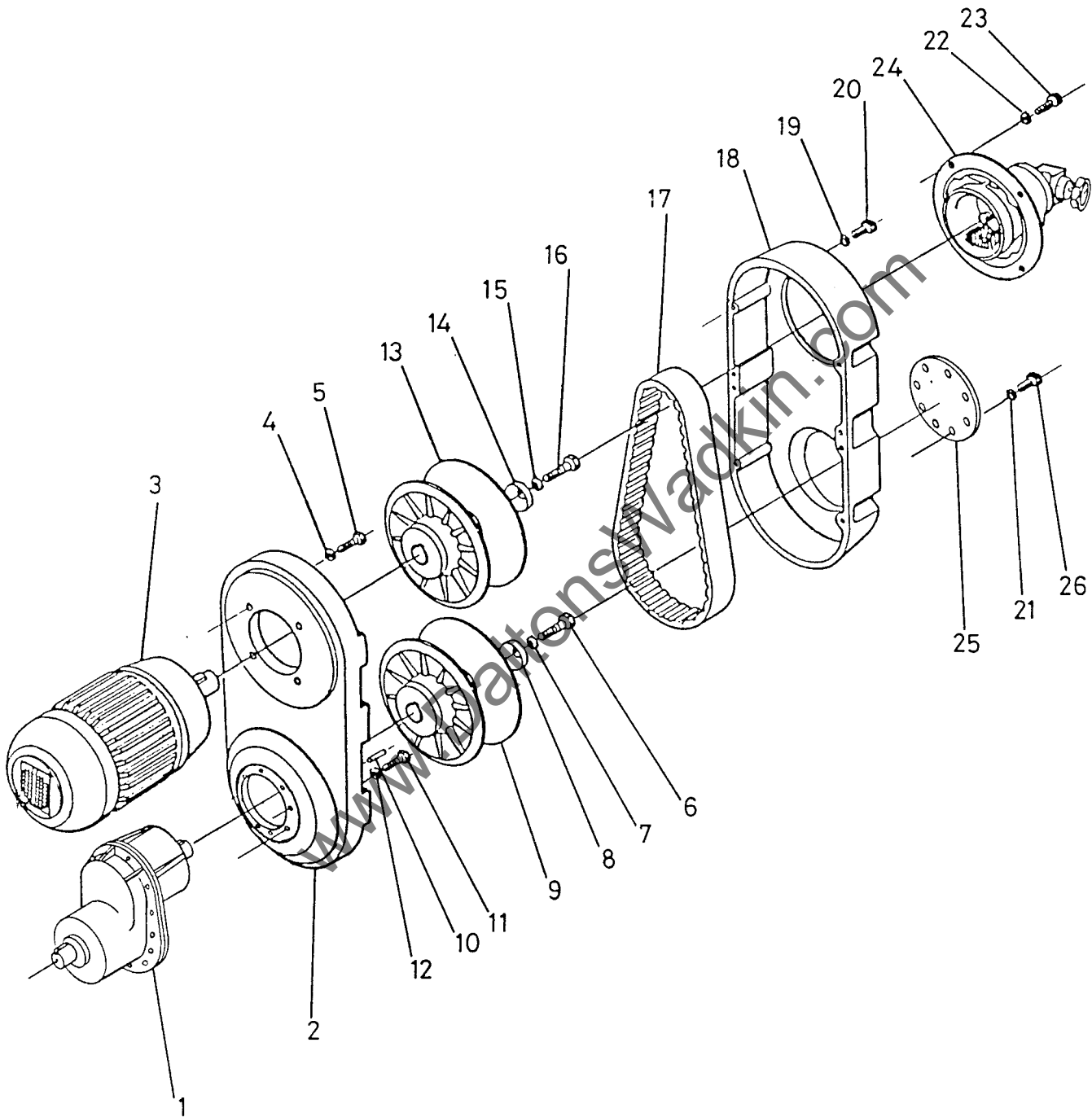

FIG 9 SIMPLABELT VARIABLE SPEED DRIVE UNIT



**9. SIMPLABELT VARIABLE SPEED DRIVE UNIT**

Ref. No.	Description	No.Off
1	Helical gear transmission (shaft drive)	1
2	Housing	1
3	Standard 3 phase motor	1
4	Lock washer, spring	4
5	Screw, hexagon head	4
6	Screw, cheese head	1
7	Washer disc, or nut	1
8	Locking plate	1
9	Pulley, spring loaded (gearbox)	1
10	Pin	1
11	Screw, hexagon head	8
12	Lock washer, spring	8
13	Pulley, mechanically adjustable (motor)	1
14	Locking plate	1
15	Washer disc, or nut	1
16	Screw, hexagon head	1
17	Vee belt, wide	1
18	Cover	1
19	Lock washer, spring	4
20	Screw, cheese head	4
21	Lock washer, spring	8
22	Lock washer, spring	4
23	Screw, cheese head	4
24	Hand adjustment	1
25	Cover plate	1
26	Screw, hexagon head	8

www.DaltonsWadkin.com

## 10. ALL SPINDLE UNITS - 40MM DIAMETER SQUARE SHOULDER

Ref. No.	Description	No. Off
1	Lock Nut	1
2	Spindle 40mm diameter square shoulder	1
3	Bearing Nut	1
4	Spindle Housing for bearing nut	1
5	Bearing RHP or SKF 6009	1
6	Barrel	1
7	Bearing RHP or SKF 6306	1
8	Parallel Key 8mmx7mmx40mm long	1
9	Pulley Spigot for spindle	1
10	Hexagon Headed Screw M12x45mm long	1
11	'Belleville' Series 'K' disc springs	6

Note: Bearings are packed with 'Kluber' Grease

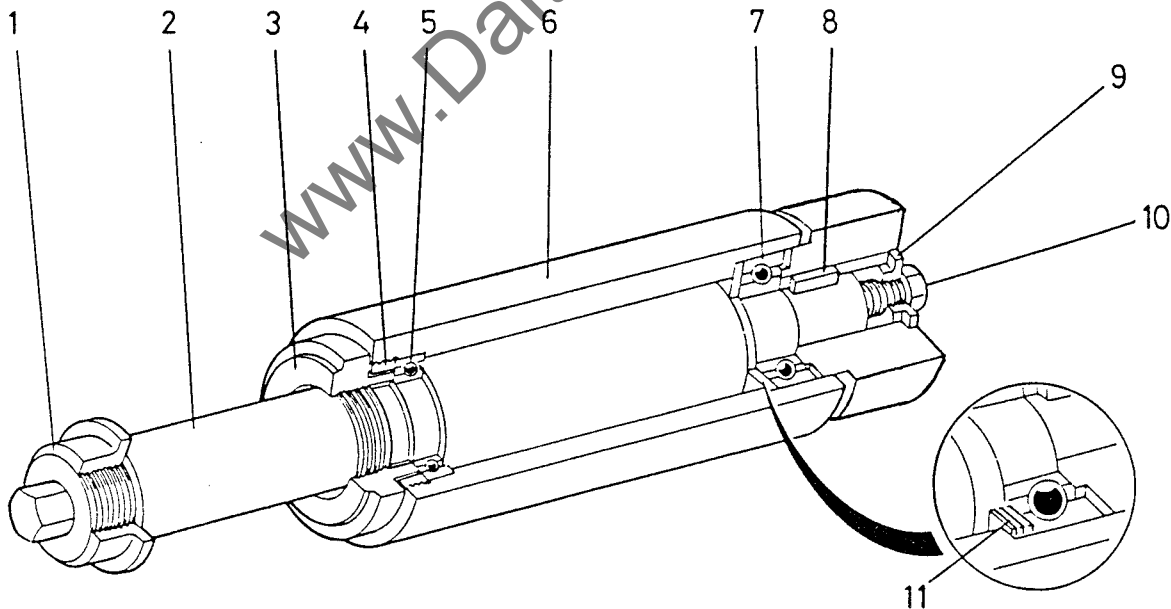

FIG 10. ALL SPINDLE UNITS - 40MM DIAMETER SQUARE SHOULDER

11. MOUNTING FOR TOP PAD OR ROLLER PRESSURE UNIT BEFORE TOP HEAD

Ref. No.	Description	No. Off
1	Bracket, top pressure	1
2	Horizontal bar, longitudinal adjustment	1
3	Horizontal bar, transverse adjustment	1
4	Split clamp, top pressure horizontal bars	1
5	Screwed stud, M10 x 55mm long	1
6	Hexagon nut, M10	1
7	Washer, 10mm, bright mild steel	1
8	Hexagon socket screw, M10 x 25mm long	2
9	Hexagon head screws, M12 x 40mm long	2

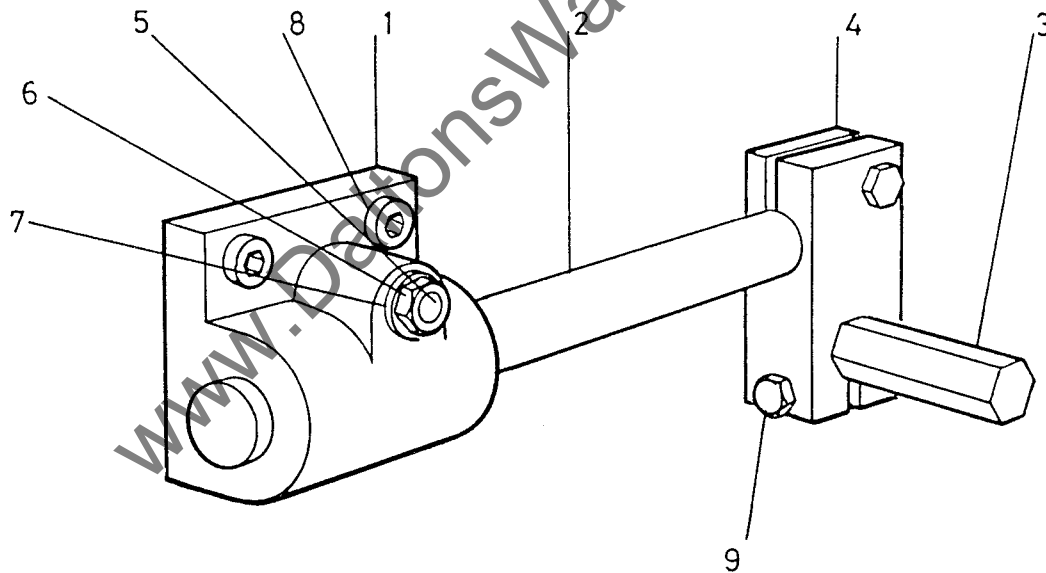

FIG 11 MOUNTING FOR TOP PAD OR ROLLER PRESSURE UNIT BEFORE TOP HEAD

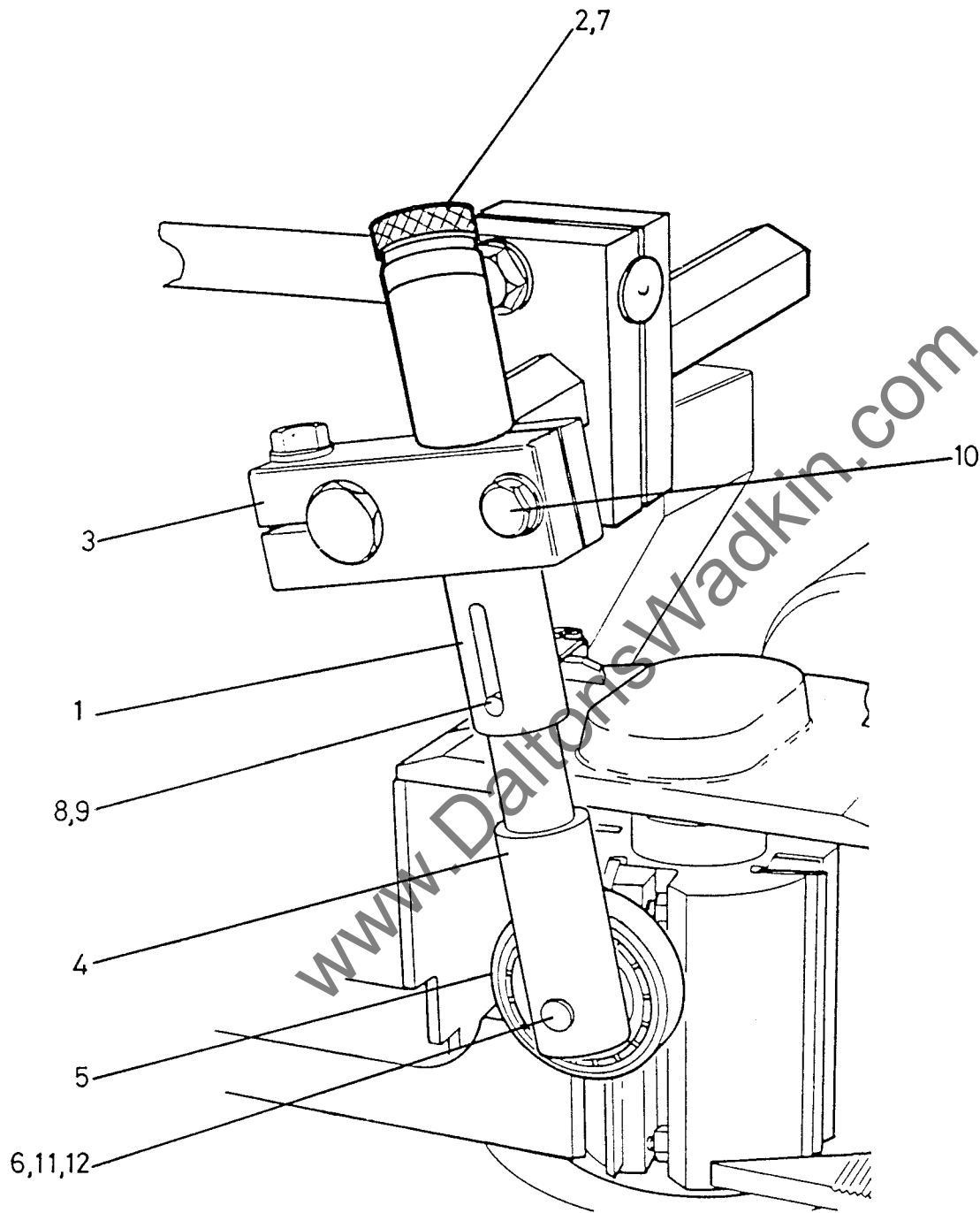

FIG 12. TOP ROLLER PRESSURE UNIT

## 12. TOP ROLLER PRESSURE UNIT

Ref. No.	Description	No. Off
1	Barrel, top pressure roller	1
2	Spring tensioner, top pressure	1
3	Split clamp, top pressure barrel	1
4	Roller arm, top pressure	1
5	Roller, top pressure	1
6	Roller pin, top pressure	1
7	Spring, infeed pressure	1
8	Tension pin, 8mm dia. x 24mm long	1
9	Tension pin, 5mm dia. x 24mm long	1
10	Hexagon head screw, M12 x 45mm long	2
11	Circlip, 20mm external	1
12	Bearing, SKF 6004 2RS	1

www.DaltonsWadkin.com

## 13. SINGLE SIDE ROLLER PRESSURE UNIT OPPOSITE FENCE SIDE HEAD

Ref. No.	Description	No. Off
1	Bracket, single roller side pressure unit	1
2	Pin, side pressure roller	1
3	Pressure roller	1
4	Sliding shaft, pressure roller	1
5	Infeed pressure spring	1
6	Hexagon head screw, M12 x 35mm long	2
7	Washer 12mm, bright mild steel	2
8	'Heyco' nylon domed plug, black, 8mm hole	1
9	Circlip, 20mm external	1
10	Bearing, SKF 6004 2RS	1
11	Tension pin, 8mm dia x 30mm long	1
12	Tension pin, 5mm dia x 30mm long	1

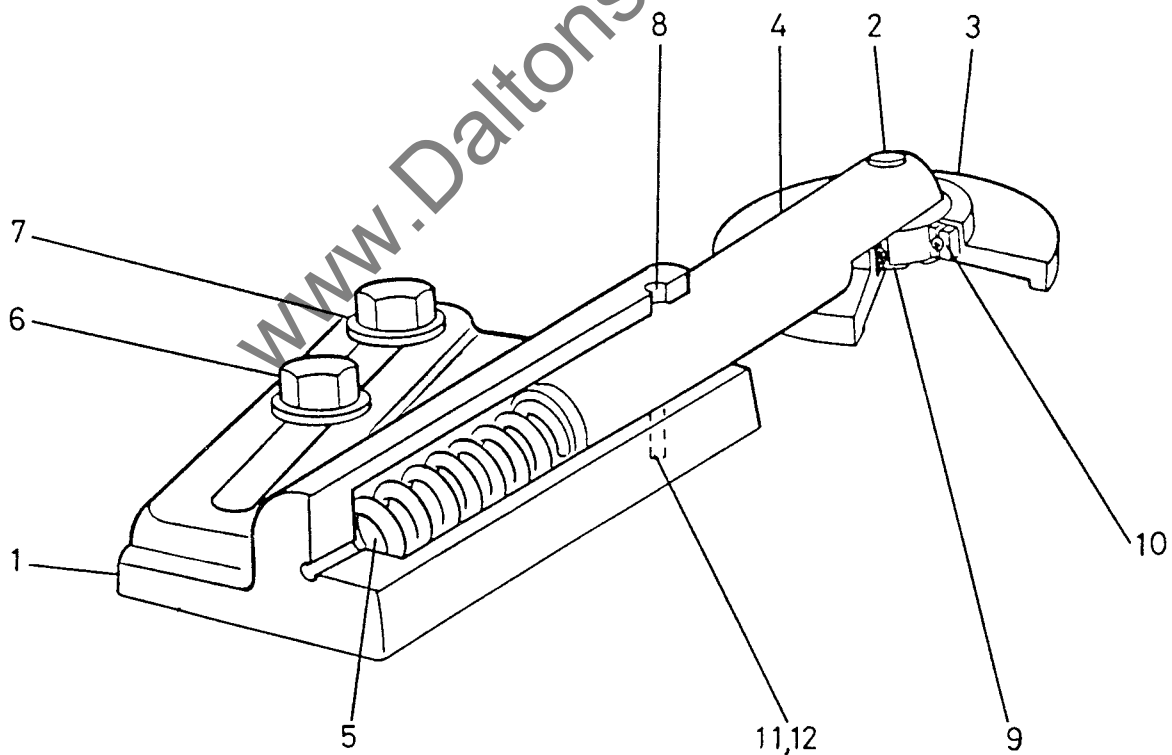

FIG 13 SINGLE SIDE ROLLER PRESSURE UNIT

14. FENCES

Ref. No.	Description	No. Off
1	Infeed fence	1
2	Shallow fence after Bottom Head	1
3	Fence before Top head	1
4	Fence after Top head	1

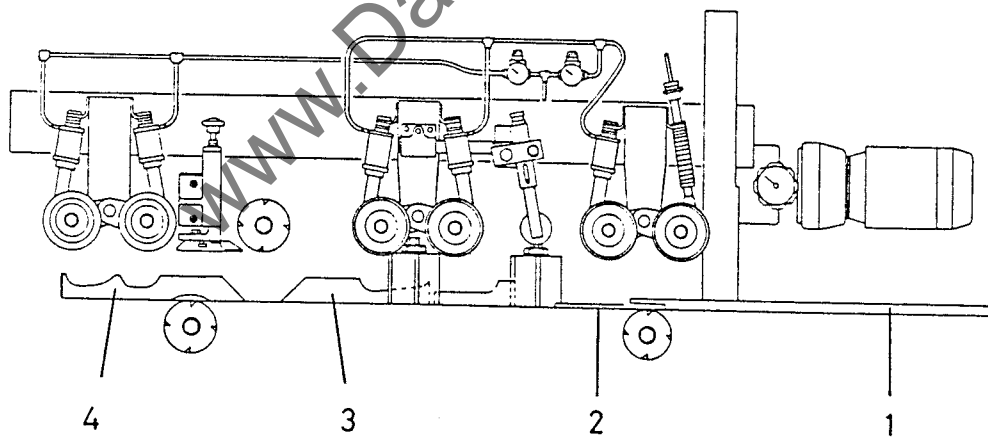

FIG 14 FENCES

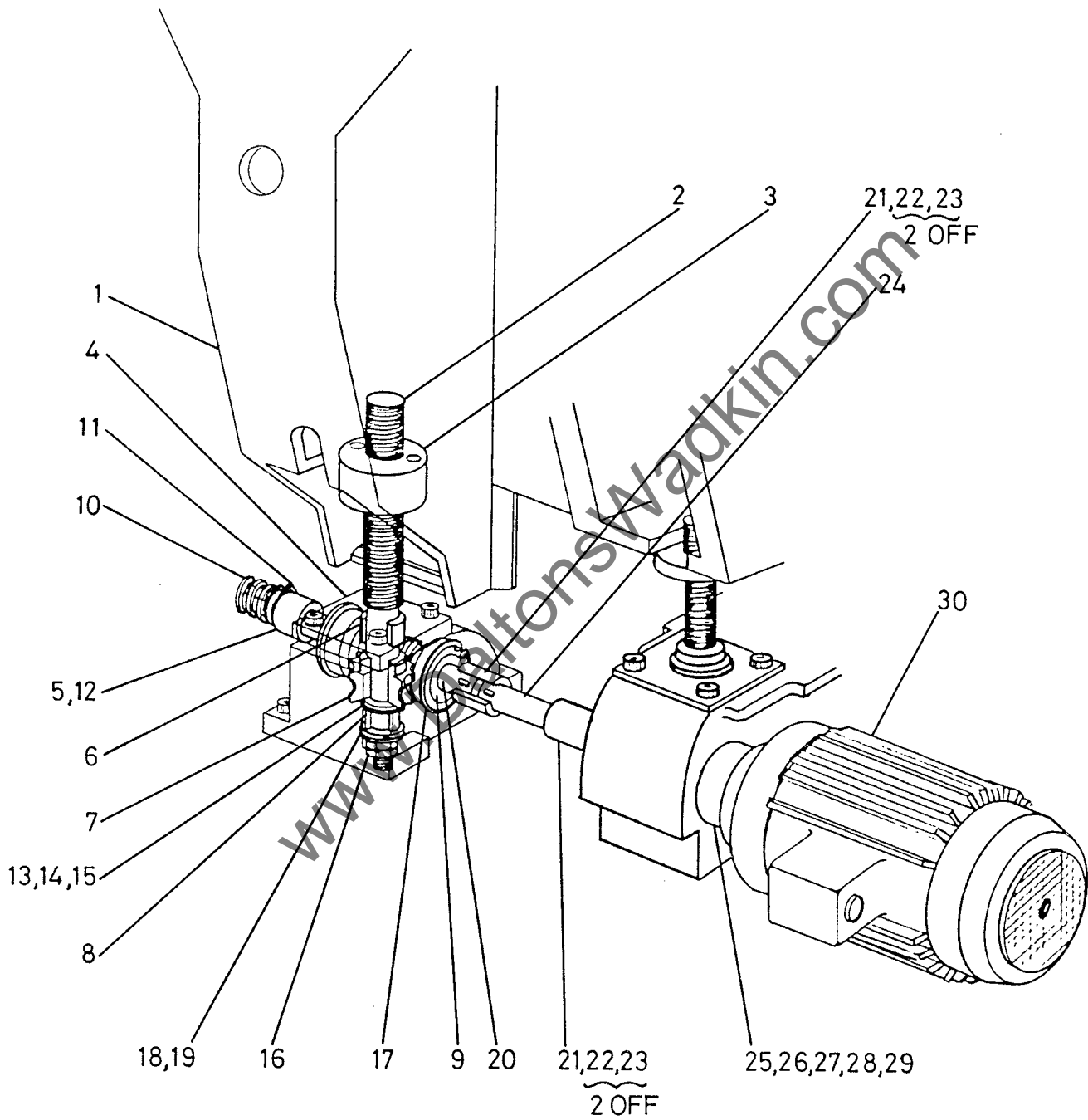

FIG. 15 BEAM POWER RISE AND FALL



15. BEAM POWER RISE AND FALL

Ref. No.	Description	No. Off
1	Top Beam, Slide Bracket	1
2	Rise and Fall Shaft for top beam	1
3	Nut for rise and fall shaft	1
4	Top cover for wormgear housing	1
5	Square End Aadapter	1
6	Bronze Oilite Bush 23mmIDx30mmODx20mm long	1
7	Wormwheel for rise and fall of top beam	1
8	Bronze Oilite Bush 20mmIDx25mmODx20mm long	1
9	Bearing SKF or RHP 6204-RS	2
10	Compression Spring 31mmIDx35mmODx50mm long	1
11	External Circlip dia. 30mm	1
12	No.2 Taper Pin	1
13	Thrust Washer INA AS 2035	1
14	Thrust Bearing INA AXK 2035	1
15	Thrust Washer INA WS 81104	1
16	Hexagon Locknut M20	2
17	Internal Circlip dia. 47mm	2
18	Thrust Washer INA A 2035	2
19	Thrust Bearing INA AXK 2035	1
20	Worm Shaft for rise and fall beam	1
21	Collar	2
22	Grub Screw M6x8mm long	4
23	Key 6mmx6mmx20mm long	4
24	Connecting Shaft	1
25	Adaptor	1
26 *	Collar	1
27 *	Key 6mmx6mmx26mm long (Motor Shaft)	1
28 *	Key 6mmx6mmx20mm long	1
29 *	Grub Screw M6x8mm long	1
30	Drive Motor	1

\* Items not illustrated (within adaptor)

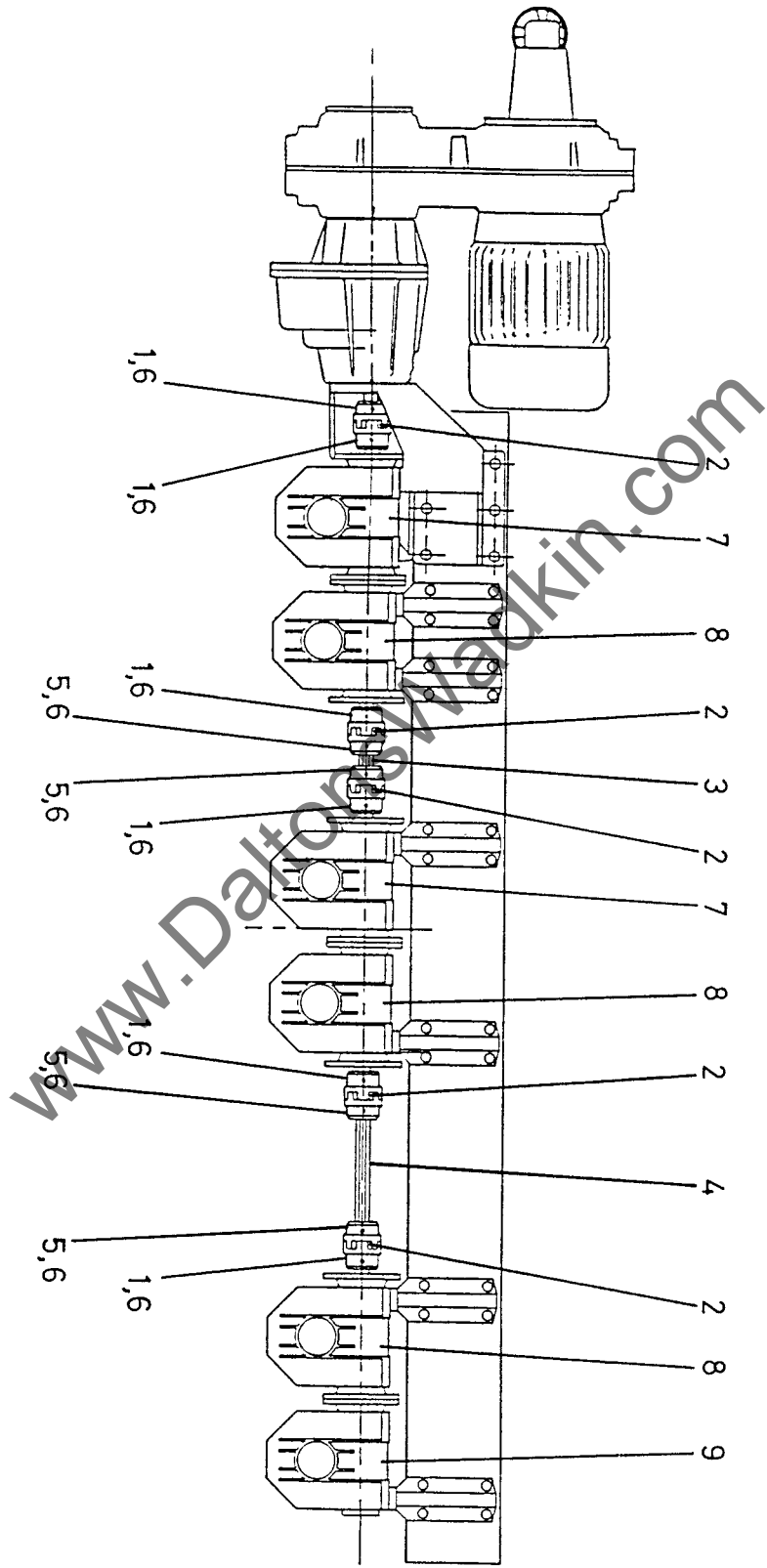

FIG16 SHAFT DRIVES AND GEARBOXES



16. SHAFT DRIVES AND GEARBOXES

Ref. No.	Description	No. Off
1	Coupling Segment 19mm Bore GA 7001	6
2	Rotex Gear Ring K30.09.899	5
3	Drive Shaft GA 6788	1
4	Drive Shaft GA 8839	1
5	Coupling Segment 19mm A/F Hex Bore GA 6801	4
6	Grub Screw M6x8mm long	10
7	Gearbox GA 7629	2
8	Gearbox GA 7445	3
9	Gearbox GA 7360	1

www.DaltonsWadkin.com

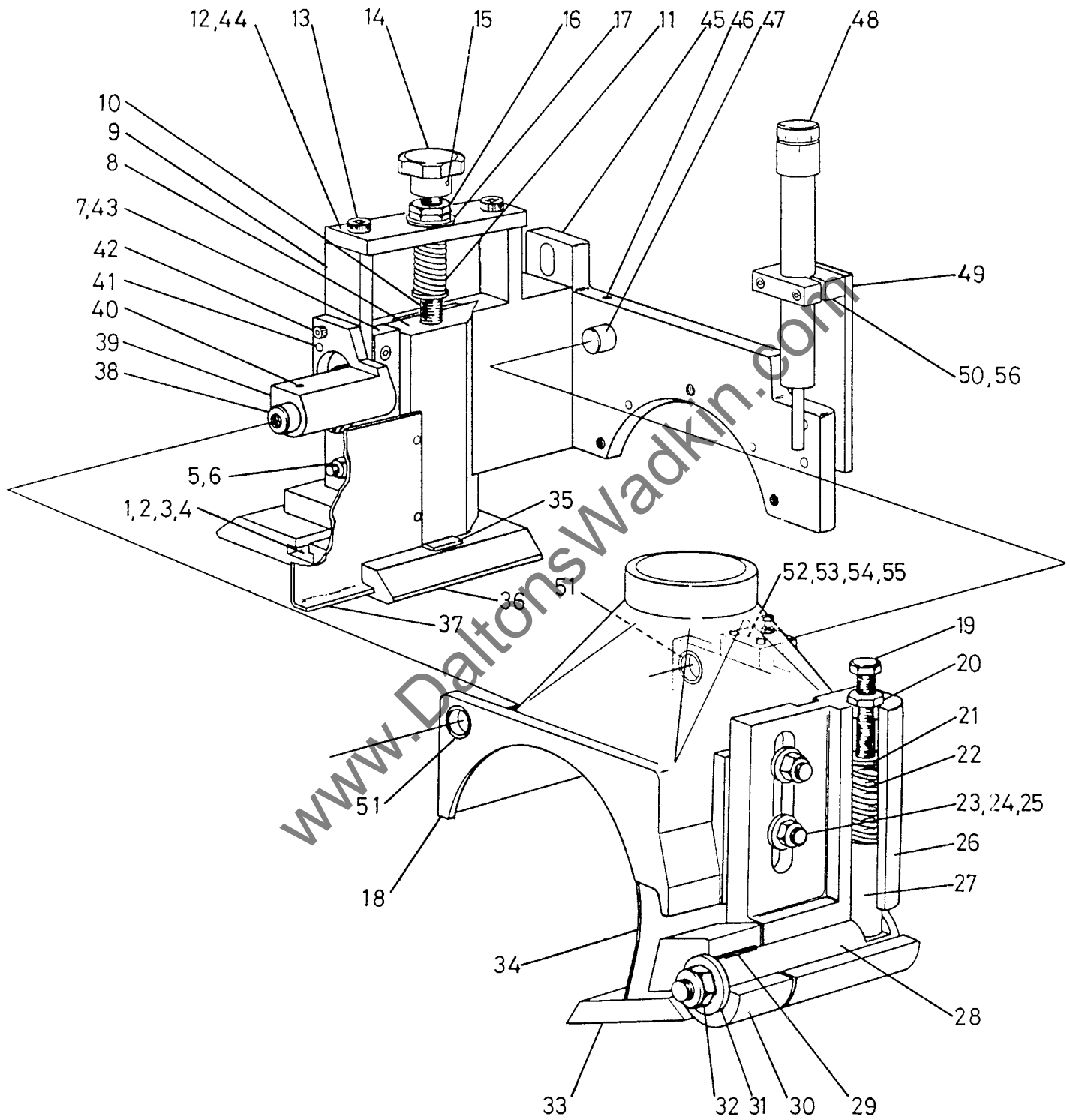

FIG 17 TOP HEAD RADIAL CHIPBREAKER, PRESSURE PAD AND EXTRACTION HOOD

FIG17 TOP HEAD RADIAL CHIPBREAKER, PRESSURE PAD AND EXTRACTION HOOD

Ref. No.	Description	No. Off
1	Tee-nut, M10, ref. WDS 664 203	2
2	Screwed stud, M10 x 45mm long	2
3	Washer 10mm, bright mild steel	2
4	Hexagon nut, M10	2
5	Hexagon socket screws, half dog point, M6x35mm long	3
6	Hexagon nut M6	3
7	Gib strip, rise and fall bracket, Top Head pressure pad	1
8	Slide, rise and fall, for shoe Top Head pressure pad	1
9	Bracket, rise and fall, Top Head pressure	1
10	Screw, raise/lower, Top Head pressure pad	1
11	Compression spring, Top Head pressure pad	1
12	Top plate, Top Head pressure pad	1
13	Hexagon socket screw, M8 x 20mm long	2
14	Handwheel, M12 blind hole	1
15	Taper pin. No 0	1
16	Hexagon nut, thin, M12	2
17	Washer, 12mm, bright mild steel	1
18	Exhaust hood, Top Head	1
19	Hexagon head screw, M12 x 40mm long	1
20	Plug, spring loaded Top Head chipbreaker	1
21	Cap, Top Head chipbreaker spring	1
22	Spring, Top Head chipbreaker	1
23	Washer, 10mm bright mild steel	1
24	Hexagon nut, M10	2
25	Screwed stud, M10 x 50mm long	2
26	Pivot bracket, Top Head chipbreaker	2
27	Plunger, spring loaded Top Head chipbreaker	1
28	Pivot shaft, Top Head chipbreaker	1
29	Parallel key, 8mm x 6mm x 32mm long	1
30	Holder, Top Head chipbreaker shoe	1
31	Washer, chipbreaker pivot shaft	1
32	Nut, M12, self locking	1
33	Shoe, Top Head, 70mm long	1
-	Shoe, Top Head, 82mm long	1
-	Shoe, Top Head, 105mm long	1
34	Chip deflector, Top Head chipbreaker	1
35	Cross tenon for shoe, top head pressure	1
36	Shoe, Top Head pressure	1
37	Cover, Top Head pressure pad	1
38	Front pivot pin	1
39	Support for pivot	1
40	Hexagon socket grubscrew M6 x 10mm long	1

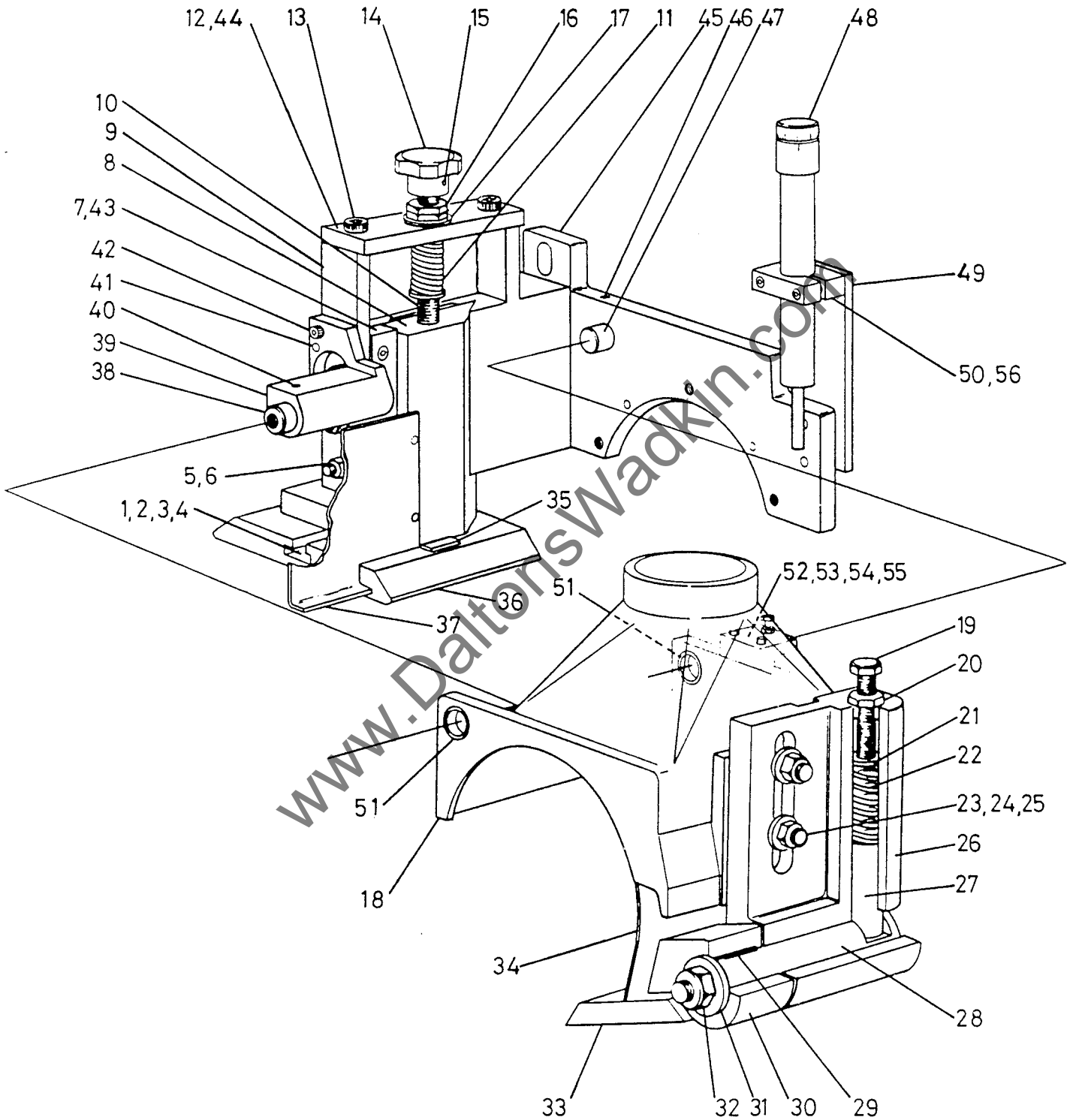

FIG17 TOP HEAD RADIAL CHIPBREAKER, PRESSURE PAD AND EXTRACTION HOOD

FIG 17 TOP HEAD RADIAL CHIPBREAKER, PRESSURE PAD AND EXTRACTION HOOD

Ref. No.	Description	No. Off
41	Tension pin $\varnothing 6$ x 16mm long	2
42	Hexagon socket screw M6 x 20mm long	2
43	Hexagon socket screw M6 x 20mm long	3
44	Bronze headed bush 12mm I/D x 18mm O/D x 8mm long	1
45	Backplate	1
46	Hexagon socket grub screw M6 x 12 long	1
47	Rear pivot pin	1
48	Hydraulic damper	1
49	Support plate for damper	1
50	Clamp block for damper	1
51	Plain bronze bush 20mm I/D x 25mm O/D x 15mm long	2
52	Stop block	1
53	Hexagon socket screw M6 x 30mm long	2
54	Hexagon head screw M8 x 20mm long	1
55	Lock nut M8	1
56	Hexagon socket screw M6 x 55mm long	2

www.DaltonsWadkin.com

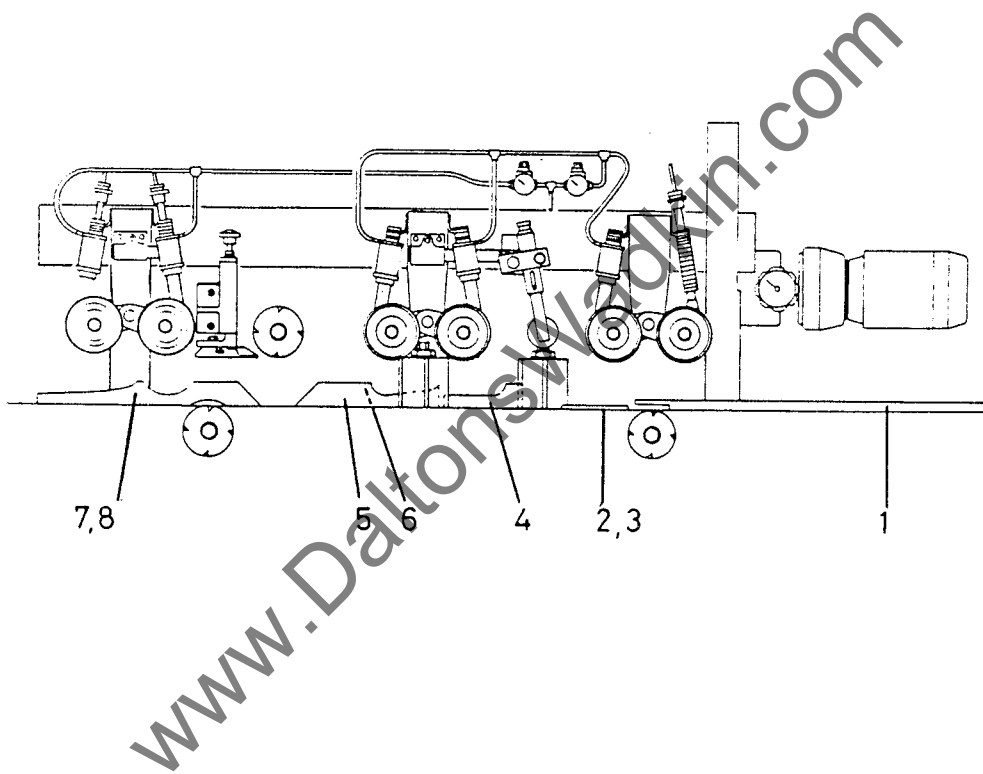

FIG 18 FENCES





18. STANDARD FENCES

Ref. No.	Description	No. Off
1	Infeed fence - 2 meter edge rebating	1
2	Fence nose piece before fence side head	1
3	Serrated clamping plate for nose piece	1
4	Adjustable fence after Fence side head	1
5	Fixed fence before Top head	1
6	Fence support bar (behind items 3 and 4)	1
7	Outfeed fence	1
8	Outfeed fence support bracket	1

www.DaltonsWadkin.com

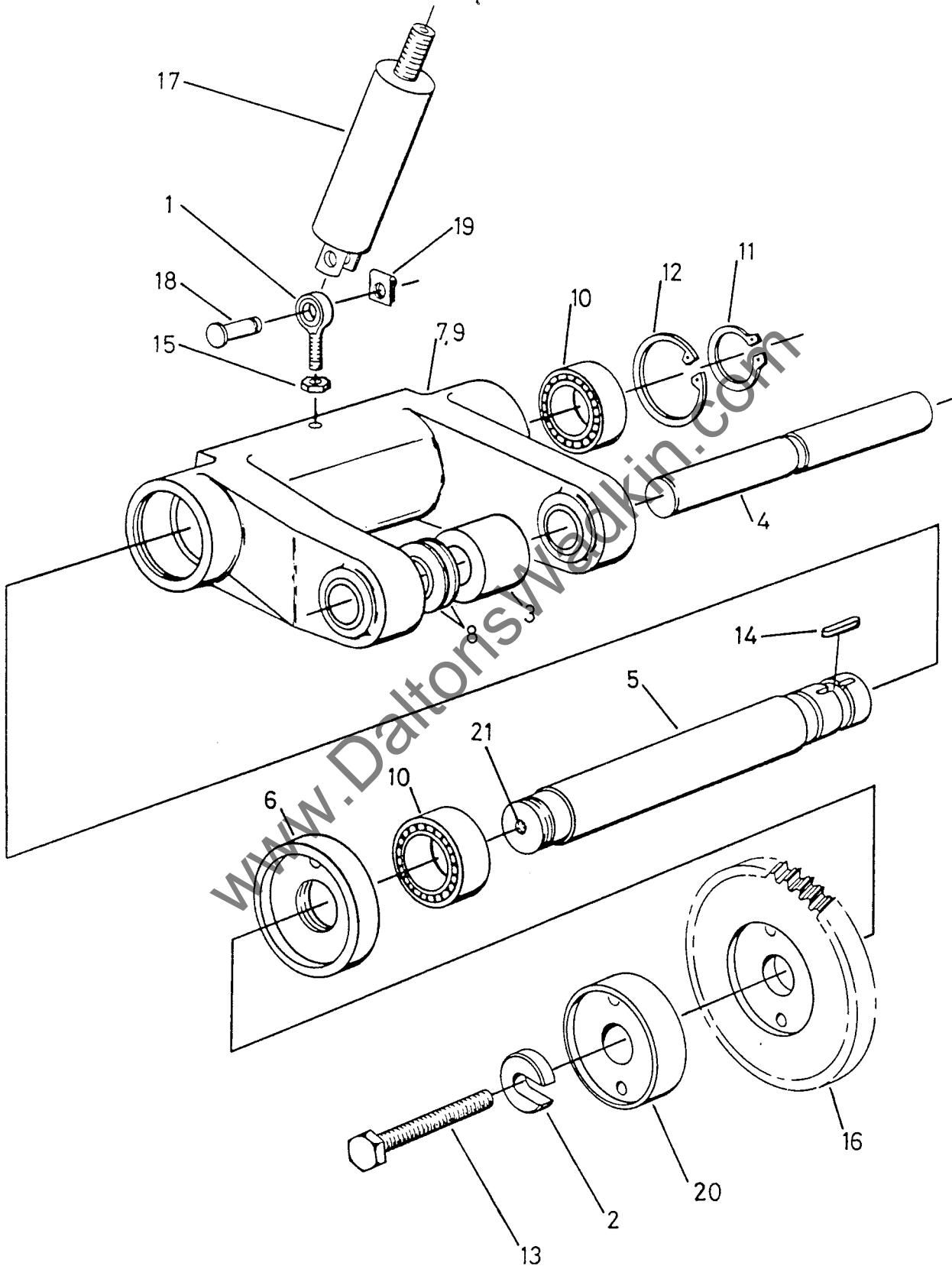

FIG 19 FLANGED MOUNTED FEEDROLL

19. FLANGE MOUNTED FEEDROLL

Ref No.	Description	No Off.
1.	Eye Bolt M12	1
2.	'C' Washer	1
3.	Spacer for Swing	1
4.	Pivot Shaft for Swing	1
5.	Feedroll Shaft	1
6.	Flange	1
7.	Feedroll Swing	1
8.	Disc Spring 50mm O/D x 25.4mm I/D x 1.5mm	2
9.	Bronze bush 30mm O/D x 25mm I/D x 25mm long	2
10.	'SKF' Bearing ref 6006-2RS	2
11.	External Circlip 30mm dia	1
12.	Internal Circlip 55mm dia	1
13.	Hexagon Head Setscrew M12 x 190mm long	1
14.	Key 8mm x 7mm x 20mm	1
15.	Locknut M12	1
16.	Feedroll complete with Location Peg (specify steel or polyurethane and also feedroll width)	
17.	Single Acting Cylinder (complete with ref 18 and 19)	1
18.	Pivot Pin (see ref 17)	1
19.	Retaining Clip (see ref 17)	1
20.	Spacer complete with Location Peg (specify width)	

**Note:** The swing, depending on location, may not require items 3 and/or 8 (spacer and disc spring). It may also be mounted in the reverse position to that shown i.e. with the cranked arm to the rear.

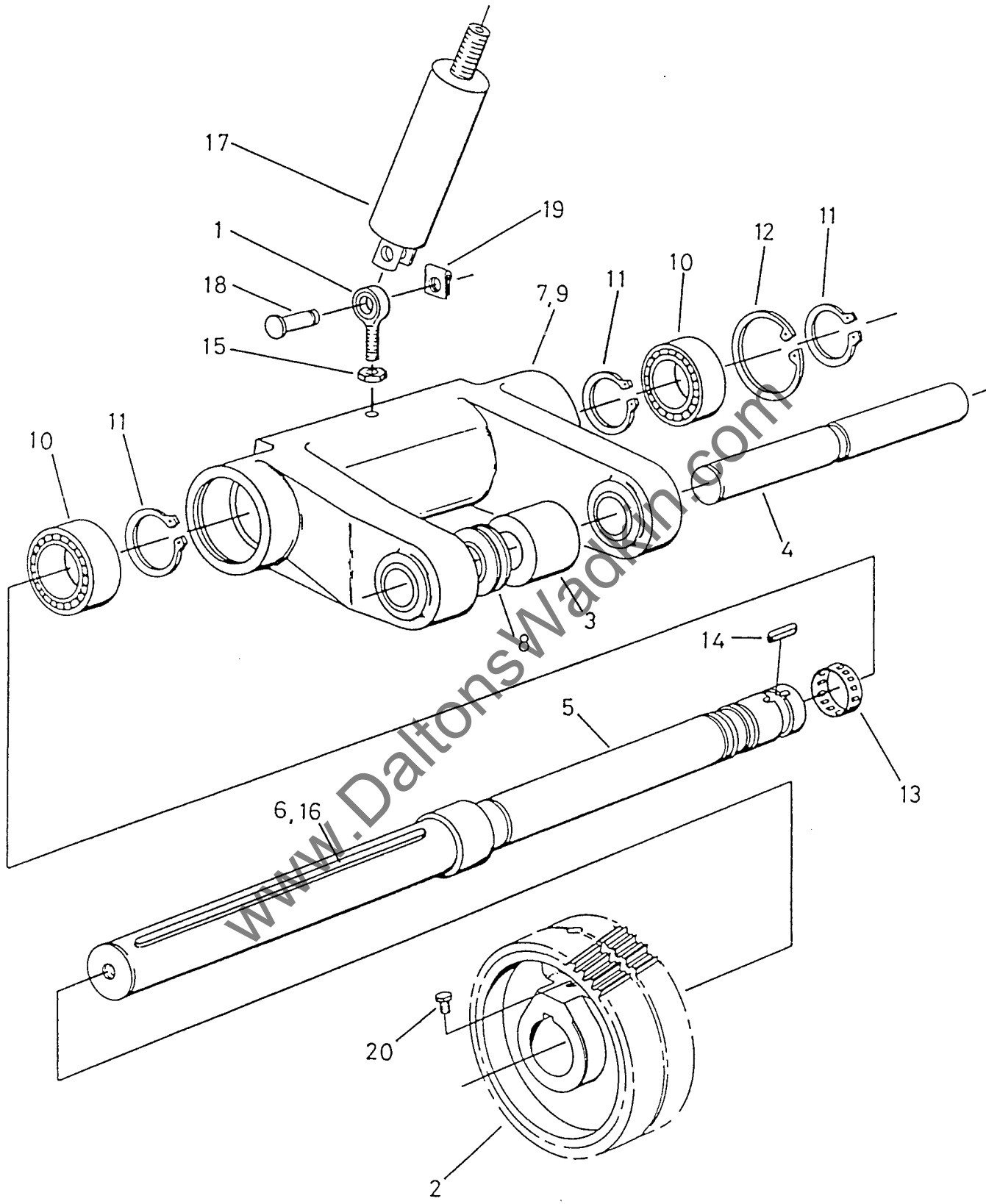

FIG 20 SHAFT MOUNTED FEEDROLL

20. SHAFT MOUNTED FEEDROLLERS

Ref No.	Description	No Off.
1.	Eye Bolt M12	1
2.	Feedroll (specify steel or polyurethane and roller width)	1
3.	Spacer for Swing	1
4.	Pivot Shaft for Swing	1
5.	Feedroll Shaft	1
6.	Key	1
7.	Feedroll Swing	1
8.	Disc Spring 50mm O/D x 25.4mm I/D x 1.5mm	2
9.	Bronze Bush 30mm O/D x 25mm I/D x 25mm long	2
10.	'SKF' Bearing ref 6006-2RS	2
11.	External Circlip 30mm dia	3
12.	Internal Circlip 55mm dia	1
13.	Tolerance Ring 'Rencol' SV30 x 8SS	1
14.	Key 8mm x 7mm x 20mm	1
15.	Locknut M12	1
16.	Hexagon Socket Countersunk Screw M4 x 12mm long	2
17.	Single Acting Cylinder (complete with ref 18 and 19)	1
18.	Pivot Pin (see ref 17)	1
19.	Retaining Clip (see ref 17)	1
20.	Hexagon Head Setscrew M10 x 16mm long	1

**Note:** The swing, depending on location, may not require items 3 and/or 8 (spacer and disc spring). It may also be mounted in the reverse position to that shown i.e. with the cranked arm to the rear.

www.DaltonWadkin.com

**WARNING**

**DO NOT USE MACHINE UNTIL TRANSIT  
PIN IS REMOVED (SEE ILLUSTRATION)**

**WARNUNG**

DIE MASCHINE DARF NICHT BENUTZT WERDEN, BEVOR DER SICHERUNGSTIFT ENTFERNT IST.

**ADVARSEL**

BENYT IKKE DENNE MASKINE INDEN TRANSPORT SPLITTEN ER FJERNET (SE ILLUSTRATION)

**¡CUIDADO!**

NO USAR LA MAQUINA HASTA QUE EL BULÓN SEA QUITADO (VER DIBUJOS).

**VARNING**

LOSSA TRANSPORTSÄKRINGEN INNAN MASKINEN STARTAS (SE BILD NEDAN)

**ATTENTION**

N'UTILISER LA MACHINE QU'APRÈS AVOIR RETIRÉ LES VIS DE TRANSPORT (VOIR SCHÈMA CI DESSOUS).

**AVISO**

NÃO USE A MAQUINA ANTES DE RETIRAR A CAVILHA DE SEGURANÇA DETRANSPORTE (VEJA ILUSTRAÇÃO)

**ATTENZIONE**

NON UTILIZZARE LA MACCHINA SE IL TASSELLO DI TRANSITO NON E'RIMOSSO (VEDERE ILLUSTRAZIONE)

**OPGEPAST**

GEBRUIK DE MACHINE NIET VOORALEER DE DOORGAANDE PIN VERWIJDERD IS (ZIE TEKENING)

**VAROITUS**

POISTA KULJETUSSOKKA ENNEN KÄYTTÖÄ (KS KUVA)

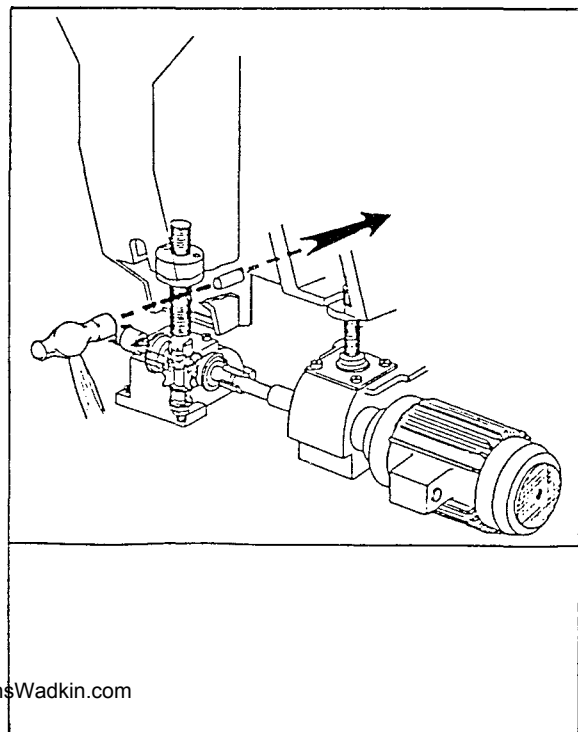
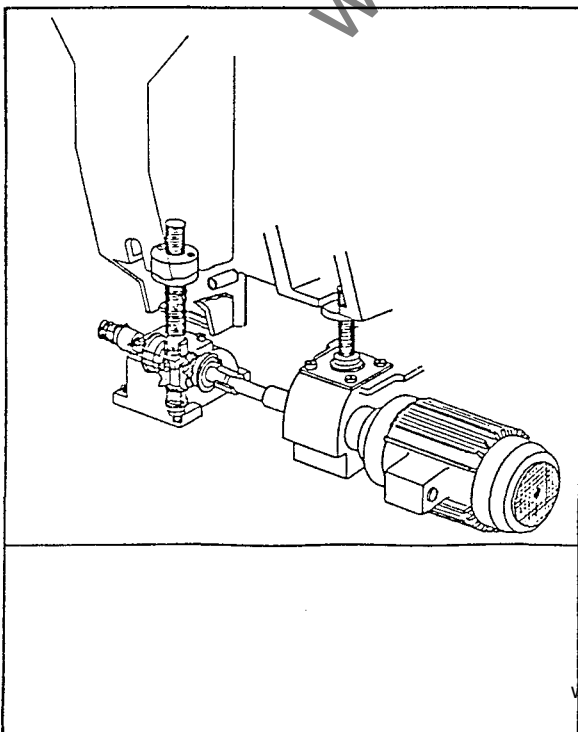



www.DaltonsWadkin.com



**WARNING**

**DO NOT USE MACHINE UNTIL TRANSIT  
PIN IS REMOVED (SEE ILLUSTRATION)**

**WARNUNG**

DIE MASCHINE DARF NICHT BENUTZT WERDEN, BEVOR DER SICHERUNGSSTIFT ENTFERNT IST.

**¡CUIDADO!**

NO USAR LA MAQUINA HASTA QUE EL BULÓN SEA QUITADO (VER DIBUJOS).

**ATTENTION**

N'UTILISER LA MACHINE QU'APRÈS AVOIR RETIRÉ LES VIS DE TRANSPORT (VOIR SCHÉMA CI DESSOUS).

**ATTENZIONE**

NON UTILIZZARE LA MACCHINA SE IL TASSELLO DI TRANSITO NON È RIMOSSO (VEDERE ILLUSTRAZIONE)

**VAROITUS**

POISTA KULJETUSSOKKA ENNEN KÄYTTÖÄ (KSKUVA)

**ADVARSEL**

BENYT IKKE DENNE MASKINE INDEN TRANSPORT SPLITTEN ER FJERNET (SE ILLUSTRATION)

**VARNING**

LOSSA TRANSPORTSÄKRINGEN INNAN MASKINEN STARTAS (SE BILD NEDAN)

**AVISO**

NÃO USE A MAQUINA ANTES DE RETIRAR A CAVILHA DE SEGURANÇA DE TRANSPORTE (VEJA ILUSTRAÇÃO)

**OPGEPAST**

GEBUIK DE MACHINE NIET VOORALEER DE DOORGAANDE PIN VERWIJDERD IS (ZIE TEKENING)

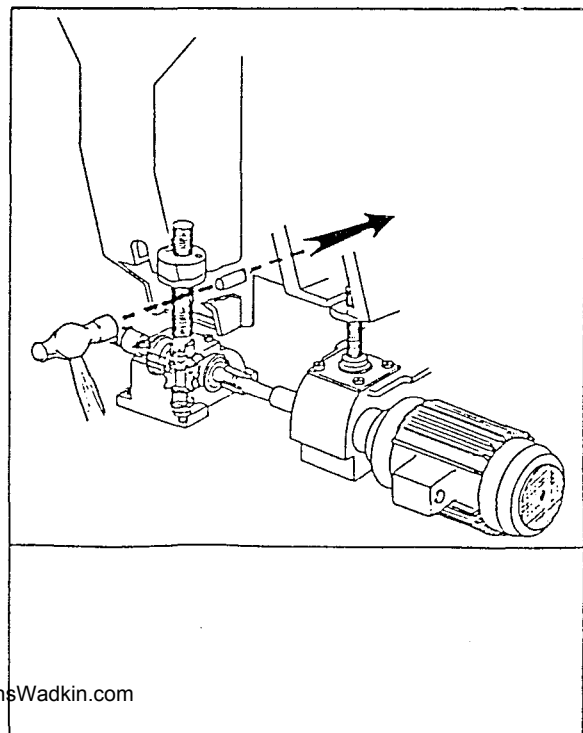
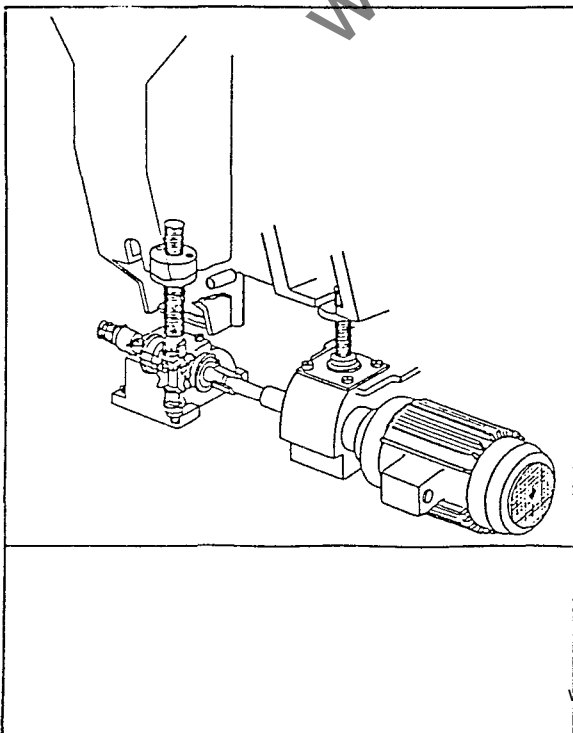





www.DaltonsWadkin.com





# Order Form & Information

Wadkin North America can supply virtually any cutterhead for virtually any machine. When ordering, please supply us with the following information to assist us in accommodating your needs. Thank you for your order.

Contact Us By Phone: 336-665-1907, Fax: 336-665-0576 or E-Mail: [sales@wadkintooling.com](mailto:sales@wadkintooling.com)

### Moulder Information

### Cutter Head Information

Make of Machine: \_\_\_\_\_  
 Model of Machine: \_\_\_\_\_  
 Bore Size: \_\_\_\_\_ Bore Type: \_\_\_\_\_  
 Body Diameter: \_\_\_\_\_

Number of Knives: \_\_\_\_\_  
 Length of Cut: \_\_\_\_\_  
 Type of Knife: \_\_\_\_\_  
 Cutting Angle: \_\_\_\_\_

Company: \_\_\_\_\_  
 Contact: \_\_\_\_\_  
 Billing Address: \_\_\_\_\_  
 City: \_\_\_\_\_  
 State: \_\_\_\_\_ Zip: \_\_\_\_\_

Phone: (\_\_\_\_) \_\_\_\_\_ Date: \_\_\_\_/\_\_\_\_/\_\_\_\_  
 Fax: \_\_\_\_\_  
 Shipping Address: \_\_\_\_\_  
 City: \_\_\_\_\_  
 State: \_\_\_\_\_ Zip: \_\_\_\_\_

Page #	Part #	Description	Price Ea.	Qty.	Total

Method of Payment:  Cash  Check  C.O.D.  Add to our Account  
 \*Orders Shipped to NC require 6-1/2% Sales Tax • Account #: \_\_\_\_\_

Visa  M/C  Discover •••••  
 Account # on Card Exp Date:

Special Instructions: \_\_\_\_\_ Authorized Signature: \_\_\_\_\_  
 \_\_\_\_\_ Method of Shipping: \_\_\_\_\_

Copy this form and use it whenever you order