

WADKIN LTD

FBN 230

**PLANING & MOULDING
MACHINE**

www.DaltonsWadkin.com

ALWAYS QUOTE MODEL AND MACHINE NUMBER WHEN ORDERING SPARES

SPARE PARTS

SHOULD SPARE PARTS BE REQUIRED DUE TO BREAKAGE OR WEAR, FULL PARTICULARS INCLUDING MACHINE AND TEST NUMBER MUST BE GIVEN, THIS INFORMATION IS ON THE NAMEPLATE ATTACHED TO THE FRONT OF THE MACHINE AND SHOULD BE FORWARDED TO THE SERVICE MANAGER.

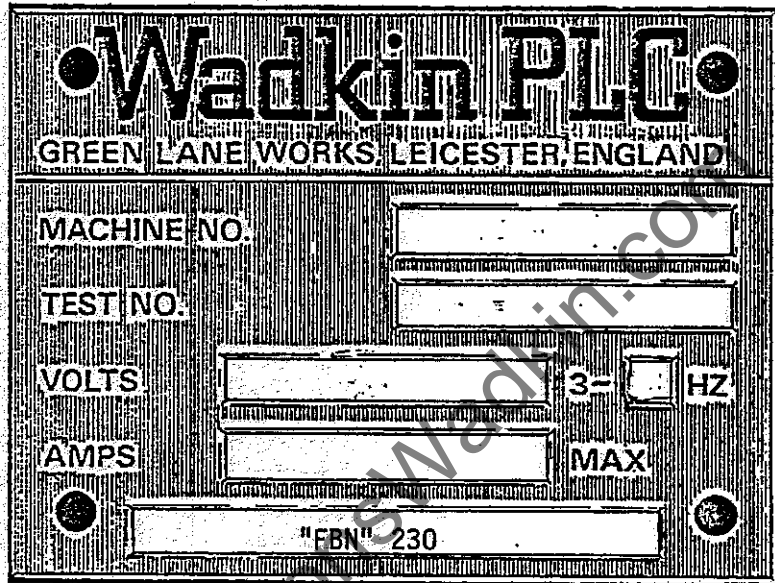

SAMPLE TYPE ORDER

MACHINE

MACHINE NO:

TEST NO:

PARTS REQUIRED

- 1 - M10 x 50mm. long screwed stud
- 1 - M10 size. bright mild steel washers
- 1 - Raising screw

Wadkin PLC., Green Lane Works. Leicester LE5 4PF

Telephone: 0533 769111

Cables: Woodworker Leicester

Telex: 34646 (Wadkin Leicester)

INDEX

SECTION ONE - FBN 230

FBN 230	Page 1
Head Arrangements	Page 3
Disposition of Feed Rolls	Page 6
Principal Dimensions and Capacities	Page 7

SECTION TWO - INSTALLATION AND ELECTRICAL CONTROLS

Installation	Page 9
Electrical Controls	Page 10

SECTION THREE - ADJUSTMENTS

The Feedworks	Page 11
First Bottom Horizontal Head	Page 17
Top Head and Chipbreaker	Page 18
Fence Side Head	Page 19
Side Heads	Page 20
Second Bottom Head	Page 21
Horizontal Head Drives	Page 22
Side Head Drives	Page 23
Near Side Head Chipbreaker	Page 24
Fences and Timber Guide	Page 25
Removal of Feed Rolls	Page 27
Top Pad Pressure	Page 28
Top Roller Pressure	Page 29
Side Pressures	Page 30
Fences and Timber Guide	Page 31

SECTION FOUR - PREPARATORY STEPS TO MACHINING

Preparatory Steps to Machining	Page 33
Machining	Page 35

SECTION FIVE - JOINTING

Jointing	Page 37
Procedure prior to Jointing	Page 38
Jointers - Parts Lists	Page 39

SECTION SIX - ALTERNATIVE PRESSURES

Pressures	Page 45
-----------	---------

SECTION SEVEN - LUBRICATION AND MAINTENANCE

Lubrication and Maintenance	Page 59
Pneumatic Piping Diagram for Feedworks	Page 61
Changing the Bearings	Page 62
Fitting the Bearings	Page 64
Replacement of Parts Associated with the Motor Pulleys	Page 65

SECTION EIGHT - PARTS LISTS

First Bottom Horizontal Head Spindles 40mm.dia. with spring loaded permanently lubricated bearings	page 67
First Top Horizontal head spindle 40mm.dia. with spring loaded oil lubricated bearings	page 69
40mm. dia. Belt Driven spindle unit for Fence Side Vertical Head	page 71
40mm. dia. Belt Driven Spindle Unit for Near side Head	page 73
First Bottom Horizontal Head spindle 1.13/16in. dia. spring loaded permanently lubricated bearings	page 76
First Top Horizontal Head spindle 1.13/16in. dia. Spring Loaded oil lubricated bearings	page 78
1.13/16in. dia. Belt Driven Spindle Unit for fence side Vertical head	page 80
1.13/16in. dia. Belt Driven Spindle Unit for Nearside Head	page 82
Bottom Horizontal Head Spindle. 1.13/16in. dia. with permanently lubricated angular contact bearing	page 85
Top Horizontal head spindle 1.13/16in. dia. with permanently lubricated angular contact bearings	page 86
Fence Side Vertical Head spindle 1.13/16in. with angular contact bearings	page 87
Near Side Vertical head spindle 1.13/16in. with angular contact bearings	page 88
Belt driven 40mm. dia. spindle Universal Head with spring loaded deep groove ball bearings	page 90
Gearbox	page 92
Gearbox - Enclosed feedworks	page 95
Top cover - Enclosed Feedworks	page 97
Enclosed feedworks - top	page 99
Enclosed feedworks - bottom	page 102

SECTION NINE - PRESSURE PARTS LISTS

Roller Pressure Over First Bottom Horizontal Head	page 105
Wide Roller pressure After First Bottom Horizontal Head	page 107
Top Roller Pressure Between 12in. Stagger side Heads for narrow stock	page 109
Top Roller pressure Between Side Heads	page 111
Side Pad Pressure After Side Heads	page 113
Side Pad Pressure After Second Top Head	page 115
Wide Top Pad Pressure Opposite Near Side Head	page 117
Wide Top Pad Pressure Before Second Top Head	page 120
Wide Top Pad Pressure After Top head	page 123
Side Pressure Before Feedrolls	page 125
Side Pressure Before First Bottom Horizontal Head	page 127
Top Pad Pressure After Universal Head	page 129
Wide Top Pad Pressure Before Universal Head	page 132

SECTION TEN - FENCE PARTS LISTS

Model No.1	page 135
Model No.2.	page 136
Model No.5	page 137
Model No.6	page 138
Model No.1U	page 139
Model No.2U	page 141
Model No.5U	page 143
Model No.6U	page 145

SECTION ELEVEN - BEDPLATES

Model No.1	page 147
Model No.2	page 148
Model No.5	page 149
Model No.6	page 150
Model No.1U	page 151
Model No.2U	page 152
Model No.5U	page 153
Model No.6U	page 154

SECTION TWELVE - UNIVERSAL HEAD

Universal head	page 155
Adjustments	page 156
Universal head drive - belt replacement	page 158

www.DaltonsWadkin.com

FBN 230

1. Mark III Feedworks
2. Vertical Adjustment - Infeed Table
3. Vertical Adjustment - Bottom Feedrolls
4. Side Pressure
5. First Bottom Head
6. Trunking with Push Button Controls
7. First Top Head
8. Vertical Adjustment - First Top Head
9. Outboard Bearing for First Top Head
10. Horizontal Adjustment - Fence Side Head
11. Side Pressure
12. Near Side Head
13. Near Side Head Chipbreaker
14. Vertical Adjustment - Near Side Head
15. Horizontal Adjustment - Near Side Head
16. Front Timber Guide
17. Second Top Head
18. Vertical Adjustment - Second Top Head
19. Outboard Bearing for Second Top Head
20. Vertical Adjustment - Second Bottom Head
21. Front Timber Guide
22. Second Bottom Head
23. Jointer Mounting Bracket - Second Bottom Head
24. Master Stop Button
25. Outfeed Table Slide
26. Outfeed Table
27. Console
28. Side Pressure
29. Pneumatic Control Panel
30. Vertical Adjustment - Top Feedrolls
31. Top Roller Pressure
32. Top Head Chipbreaker
33. Vertical Adjustment - Top Roller Pressure
34. Jointer Mounting Bracket - First Top Head
35. Top Pad Pressure
36. Fence Side Head
37. Top Pad Pressure
38. Vertical Adjustment - Top Pad Pressure
39. Top Head Chipbreaker
40. Jointer Mounting Bracket - Second Top Head
41. Top Pad Pressure
42. Horizontal Adjustment - Second Bottom Head

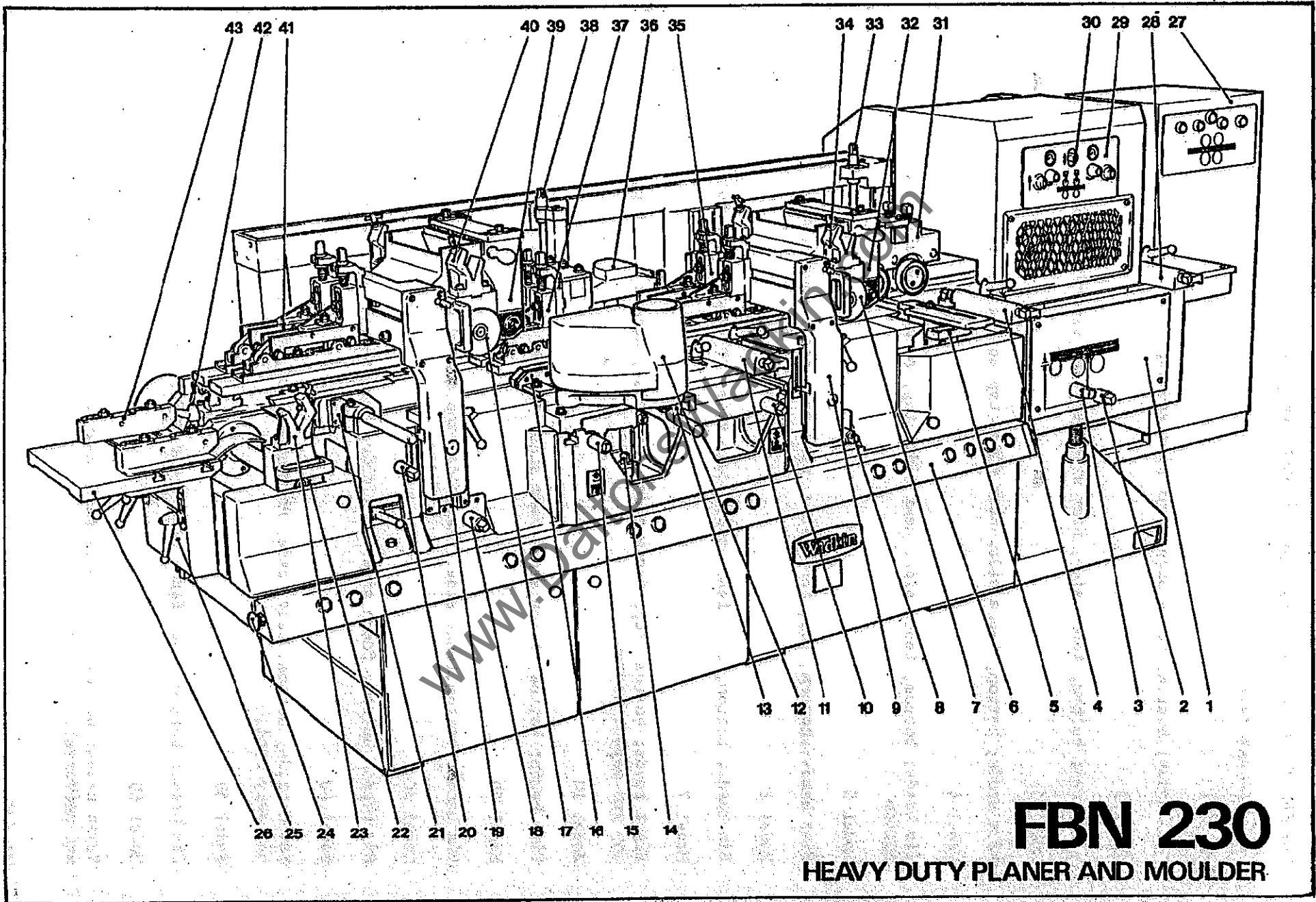

FBN 230

HEAVY DUTY PLANER AND MOULDER

The FBN 230 Heavy Duty High Speed Planer and Moulder

Head Arrangements

Model 1

Four heads; bottom, fence side, near side and top.

Model 2

Five head; bottom, fence side, near side, top and second bottom

Model 3

Five heads; bottom, fence side, near side, top and second top.

Model 4

Six heads; bottom, fence side, near side, top, second top and second bottom

Model 5

Five heads; bottom, top, fence side, near side and second top.

Model 6

Six heads; bottom, top, fence side, near side, top and second bottom.

Model 7

Eight heads; bottom, top, fence side, near side, second top, top, third top and second bottom.

Model 1U

Five heads; bottom, fence side, near side, top and universal

Model 2U

Six heads; bottom, fence side, near side, top, second bottom and universal

Model 3U

Six heads; bottom, fence side, near side, top, second top and universal.

Model 4U

Seven heads; bottom, fence side, near side, top, second top, second bottom and universal.

Model 5U

Six heads; bottom, top, fence side, near side, top and universal.

Model 6U

Seven heads; bottom, top, fence side, near side, second top, second bottom and universal.

FBN 230 GENERAL PURPOSE PLANER AND MOULDER HEAD ARRANGEMENTS

NUMBER OF HEADS	MODEL	SEQUENCE
4	1	
	2	
5	3	
	5	
6	4	
	6	

HEAD ARRANGEMENTS

NUMBER OF HEADS	MODEL	SEQUENCE
4 PLUS UNIVERSAL	1u	
5 PLUS UNIVERSAL	2u	
	3u	
6 PLUS UNIVERSAL	4u	
	5u	

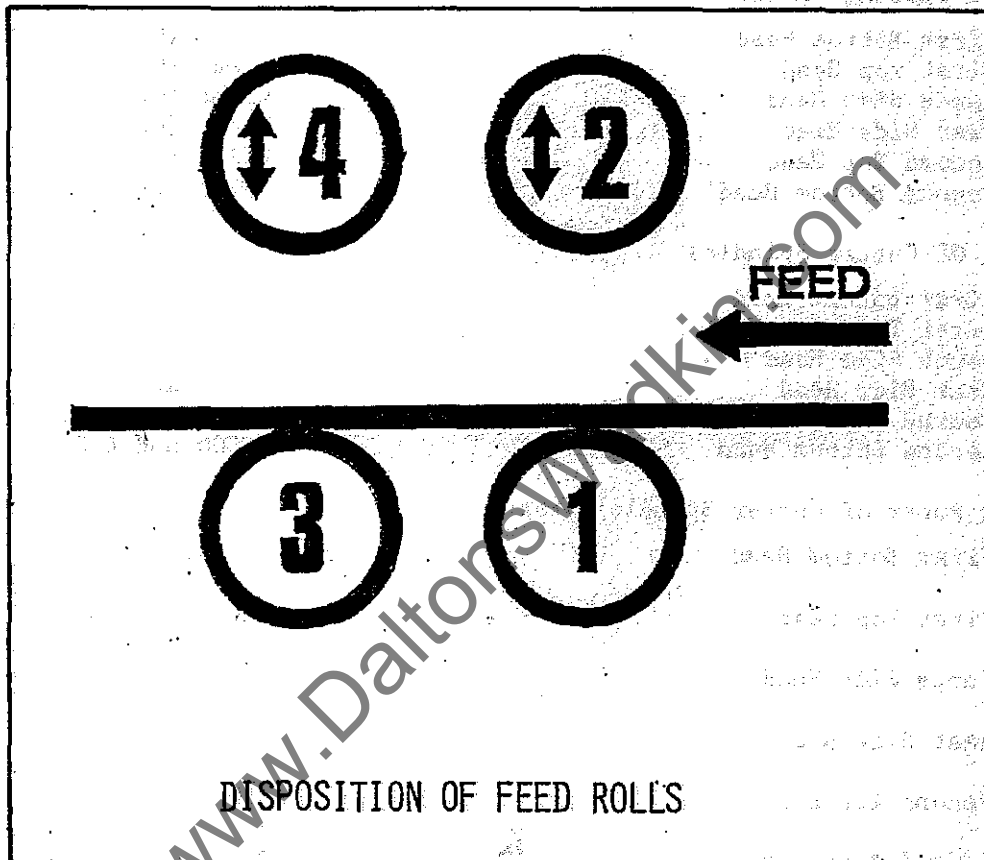

DISPOSITION OF FEED ROLLS

HEAVY DUTY HIGH SPEED PLANER AND MOULDER FBN 230**PRINCIPAL DIMENSIONS AND CAPACITIES****Maximum Cutting Circle**

First Bottom Head	190mm (7.1/2in.)
First Top Head	254mm (10in.)
Fence Side Head	215mm (8.1/2in.)
Near Side Head	215mm (8.1/2in.)
Second Top Head	254mm (10in.)
Second Bottom Head	254mm (10in.)

Minimum Cutting Circle

First Bottom Head	152mm (6in.)
First Top Head	152mm (6in.)
Fence Side Head	152mm (6in.)
Near Side Head	152mm (6in.)
Second Top Head	152mm (6in.)
Second Bottom Head	152mm (6in.)

R.P.M. Of Cutter Spindles

First Bottom Head	4,500 and 6,000
First Top Head	4,500 and 6,000
Fence Side Head	4,500 and 6,000
Near Side Head	4,500 and 6,000
Second Top Head	4,500 and 6,000
Second Bottom Head	4,500 and 6,000

Output Power of Cutter Spindle Motor

First Bottom Head	5.5 KW or 7.5 KW (7.1/2 or 10 h.p.)
First Top Head	15 KW or 7.5 KW (20 or 10 h.p.)
Fence Side Head	5.5 KW or 7.5 KW (7.1/2 or 10 h.p.)
Near Side Head	5.5 KW or 7.5 KW (7.1/2 or 10 h.p.)
Second Top Head	7.5 KW or 15 KW (10 or 20 h.p.)
Second Bottom Head	7.5 KW or 15 KW (10 or 20 h.p.)

Size of Exhaust Outlet

First Bottom Head	140 x 152mm (5.1/2 x 6in.)
First Top Head	286 x 102mm (11.1/4 x 4in.)
Fence Side Head	127mm dia. (5in. dia.)
Near Side Head	127mm dia. (5in. dia.)
Second Top Head	286 x 102mm (11.1/4 x 4in.)
Second Bottom Head	273 x 127mm (10.3/4 x 5in.)

H.P. of Feed Motor

5.5/4 KW (7.5/5.5 H.P.)

Diameter of Feed Rolls

250mm (10in.)

Feed Speeds m/min. 6, 9, 12, 13, 15, 18, 20, 23, 26, 30, 40, 45.
 ft/min. 20, 30, 40, 45, 50, 60, 65, 75, 87, 100, 130, 150

Cutter Spindle diameter

40mm

MEASUREMENTS AND WEIGHT

Bed height	838mm	33in.
Overall height	1249mm	49.125in.
Floor area (Model 6)	3775 x 1600mm	149 x 63 in.
Net weight	5025 kg	11080 lb.
Gross weight	5486 kg	12096 lb.
Shipping dimensions (Model 6)	10.076m ³	356 ft. ³

Capacity Chart

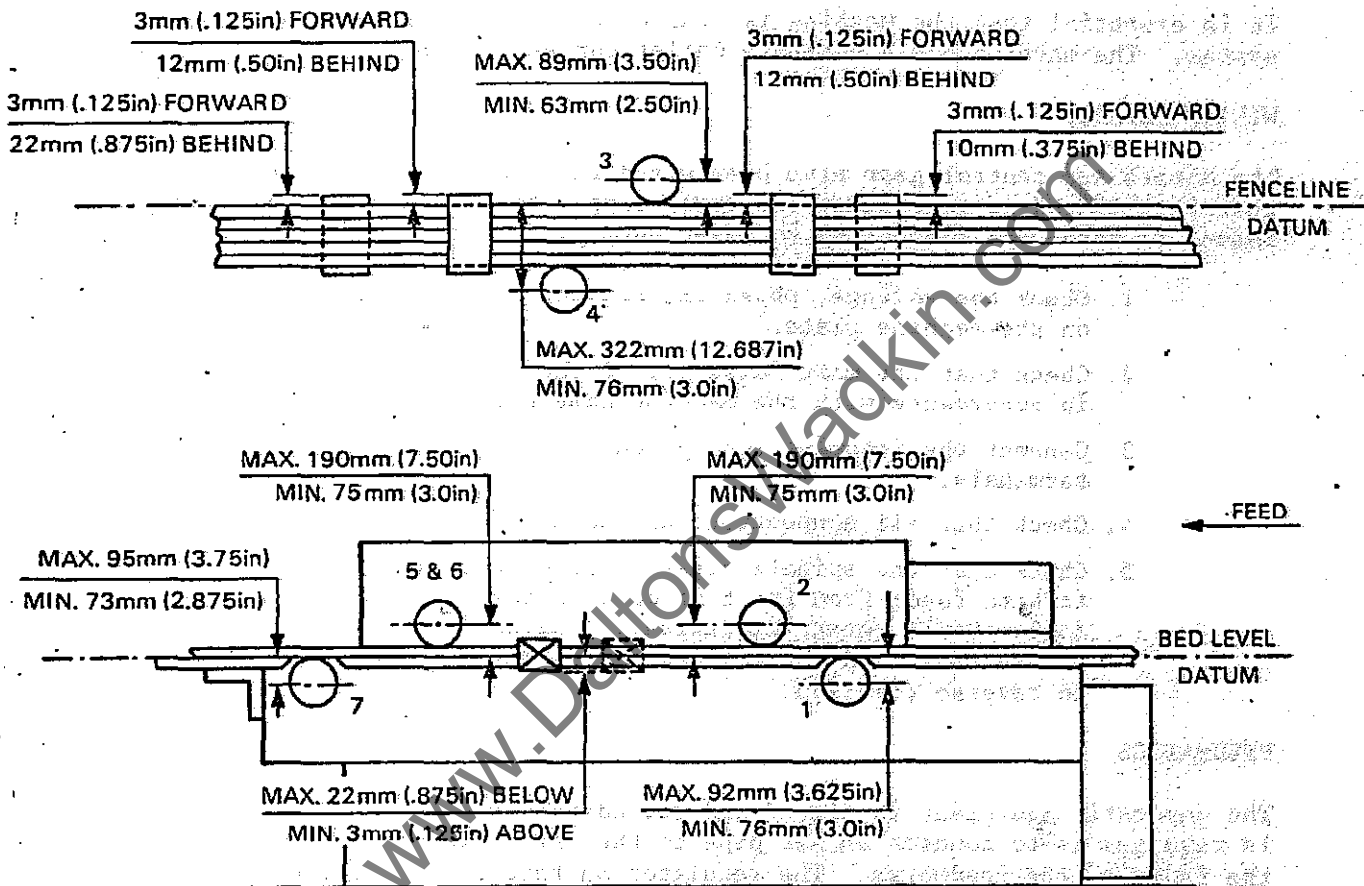

Cutting Circles

MAX. SWING DIA. D2 MIN. BASIC DIA. D1

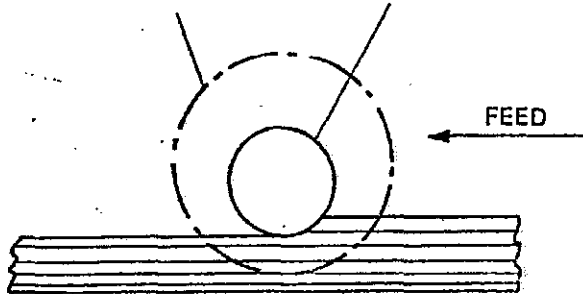

	7		5 and 6		4		3		2		1	
	mm	in	mm	in	mm	in	mm	in	mm	in	mm	in
D1	152	6	152	6	152	6	152	6	152	6	152	6
D2	254	10	254	10	216	8.5	216	8.5	254	10	190	7.5

INSTALLATION

Foundation bolts are not supplied with the machine. If the mill floor consists of 4 in. to 6 in. solid concrete, no special foundation is necessary. Rag type holding-down bolts may be used. Cut 6in. square holes in concrete for bolts. Run in liquid cement when machine has been levelled.

Clean protective coating from bright parts with cloth soaked in paraffin, turpentine or another solvent.

See foundation drawing supplied separately.

It is essential that the machine is connected to a dust collecting system. The machine has a built-in outlet for each head.

WIRING DETAILS

The motors and control gear have been wired in before despatch. All that is required is to connect the power supply to the isolating switch. Points to note when connecting to power supply:-

1. Check the voltage, phase and frequency with those on the machine plate.
2. Check that the main fuses are of the correct capacity in accordance with the machine name plate.
3. Connect the incoming supply leads to the appropriate terminals.
4. Check that all connections are sound.
5. Check that the spindle rotation is correct (start forward feed; from front of machine the top feed rolls should rotate clockwise). Reverse any two of the line lead connections of the incoming supply to reverse rotation.

PNEUMATICS

The pneumatic equipment is fitted and tested before despatch. All that is required is to connect an air pipe to the filter unit, located under the front of the feedworks. The regulator on this unit should be set to read 5.6 kg/cm² (80 p.s.i.) on the gauge.

The lubricator on this unit MUST be filled with Mobil Almo No.1 oil.

FBN 230

ELECTRICAL CONTROLS

The electrical supply isolating (disconnect) switch is situated in the main control cubicle and before any cutterhead or feed can be started the switch must be turned to the 'on' position.

The master 'lock-off' pushbuttons must be turned and released before any head or feed can be started, these buttons are situated at the infeed and outfeed end of the pushbutton channel on the front of the machine.

To start the cutterheads, first ensure that the cutterblocks are free to rotate then press the respective start pushbutton situated on the pushbutton channel, to stop the cutterhead press the associated stop button. These buttons are conveniently situated in line with the respective cutterheads.

To start the feed motor* first select the feed speed required i.e. low speed (1) or high speed (2) with the selector switch situated on the rear of the main control cubicle, then press the start feed push button at the infeed end of the machine, to stop the feed press the stop feed button. The feed rolls can be reversed by depressing and holding the inch (jog) reverse pushbutton situated at the infeed end of the machine. Similarly the feed can be 'inched' (jogged) forward by holding depressed the 'inch' (jog) pushbuttons situated at both the infeed and outfeed end of the machine. The outfeed 'inch' (jog) pushbutton when depressed will also stop the feed rolls, if it is required to inch (jog) forward the feed rolls from the outfeed end of the machine, this pushbutton reverts to its normal control function i.e. it is an inch (jog) and stop feed button.

Failure to start.

1. Electrical supply is not available
2. Fuses have blown or are not fitted
3. Isolating (disconnect) switch has not been closed
4. One or both of the master stop buttons are locked in the 'OFF' position.

Shut down during operation and failure to re-start.

1. Fuses have 'blown'
2. Overloads have tripped, these will automatically reset after a short time.

*If the machine has been supplied with a hydraulic motor then these remarks will apply only to the squirrel cage induction motor driving the pump.

WADKIN HEAVY DUTY HIGH SPEED PLANER AND MOULDER FBN 230

THE FEEDWORKS

The feedworks consist of four power driven rolls (10), (11), (12) and (13) at the infeed end of the machine. (See page)

The rolls are driven directly from a three speed gear box (19), two stepped cone pulleys (20) and (21) and two speed squirrel cage induction motor (22) to give a choice of twelve speeds 6, 9, 12, 14, 15, 18, 20, 22, 27, 30, 39, 45 metres/min. (20, 30, 40, 50, 60, 65, 75, 87, 100 130 and 150 ft/min.), these are located at the rear of the machine as is the hand operated gear lever (23) and the belt change operating lever (24), whilst the motor feed speed rotary selector switch (25) is fitted at the top right hand side of the electrical control console. The pneumatically operated feed rolls are electrically controlled from remote push buttons (1) and (2) from an independent control panel (26).

Pneumatic Controls to the Feed Works.

A pre requisite necessity before attempting to lower any of the top rolls is to ensure that the disconnect switch and master stop button are switched on at the electrical control console.

The infeed rolls are pneumatically operated from push buttons (1) and (2), the degree of pressure can be adjusted by controls (3) and (4). The respective pressure gauges are (5) and (6). Vertical adjustment to the top rolls is by cranked handle on square (7).

The bottom feed rolls are adjusted vertically by means of a crank handle on square (8) whilst the height of the rolls relative to the bedplate can be adjusted by means of a cranked handle on square (9).

The feedworks electrical control buttons are as follows:-

- Start Feed
- Stop Feed
- Jog (inch) Forward Feed
- Jog (inch) Reverse

Adjustment of the Feed Rolls

The top feed rolls (10) and (11) must be set relative to the thickness of the timber by lowering the rolls by depressing the button (2). The amount of vertical travel should be sufficient to moderately hold the workpiece in position. At this stage the workpiece should be withdrawn. Following which further vertical adjustment to the top rolls should be made by means of the crank handle on square (7). The adjustment should be such that the rolls take up a position which represents approximately 6mm (0.25 in.) less than the thickness of the workpiece. The input air pressure should be set to 5.7 kg/cm² (80 lbs./sq.in.).

To lower the Top Rolls depress button (2).

To raise the Top Rolls depress button (1) or either of the electrical master stop buttons.

The amount of pressure each top roll exerts on the timber should be such that the traction is sufficient without defacing the timber. Each roll is independently controlled. To increase the pressure to the infeed roll turn knob (3) counter clockwise. The amount of pressure applied is registered on gauge (5), knob (4) and gauge (6) similarly control the second top roll.

At the initial starting of the feed rolls a fine mist of oil should be added to the air supply by opening the regulating screw on the filter regulator oiler unit (18) for a brief period but not longer than five minutes. It will be necessary to repeat this process at intervals of two weeks.

IMPORTANT:

IF WORKING CONDITIONS DEMAND INCREASED TRACTION, INCREASE THE AIR PRESSURE AT THE REGULATORS (3) and (4) OR IF THE AIR SUPPLY HAS SUFFICIENT RESOURCES INCREASE THE PRESSURE AT THE FILTER REGULATOR UNIT (18) LOCATED UNDER THE INFEEED TABLE. UNDER NO CIRCUMSTANCES SHOULD TRACTION BE INCREASED BY THE VERTICAL ADJUSTMENT OF THE ROLLS BY MEANS OF THE CRANK HANDLE ON SQUARE (7).

FAILURE TO OBSERVE THIS PRECAUTION WILL PRECIPITATE MECHANICAL DAMAGE TO THE FEEDWORKS DRIVE.

DANGER - DO NOT ADJUST BOTTOM FEED ROLLS WHILST TOP FEED ROLLS ARE PRESSURISED

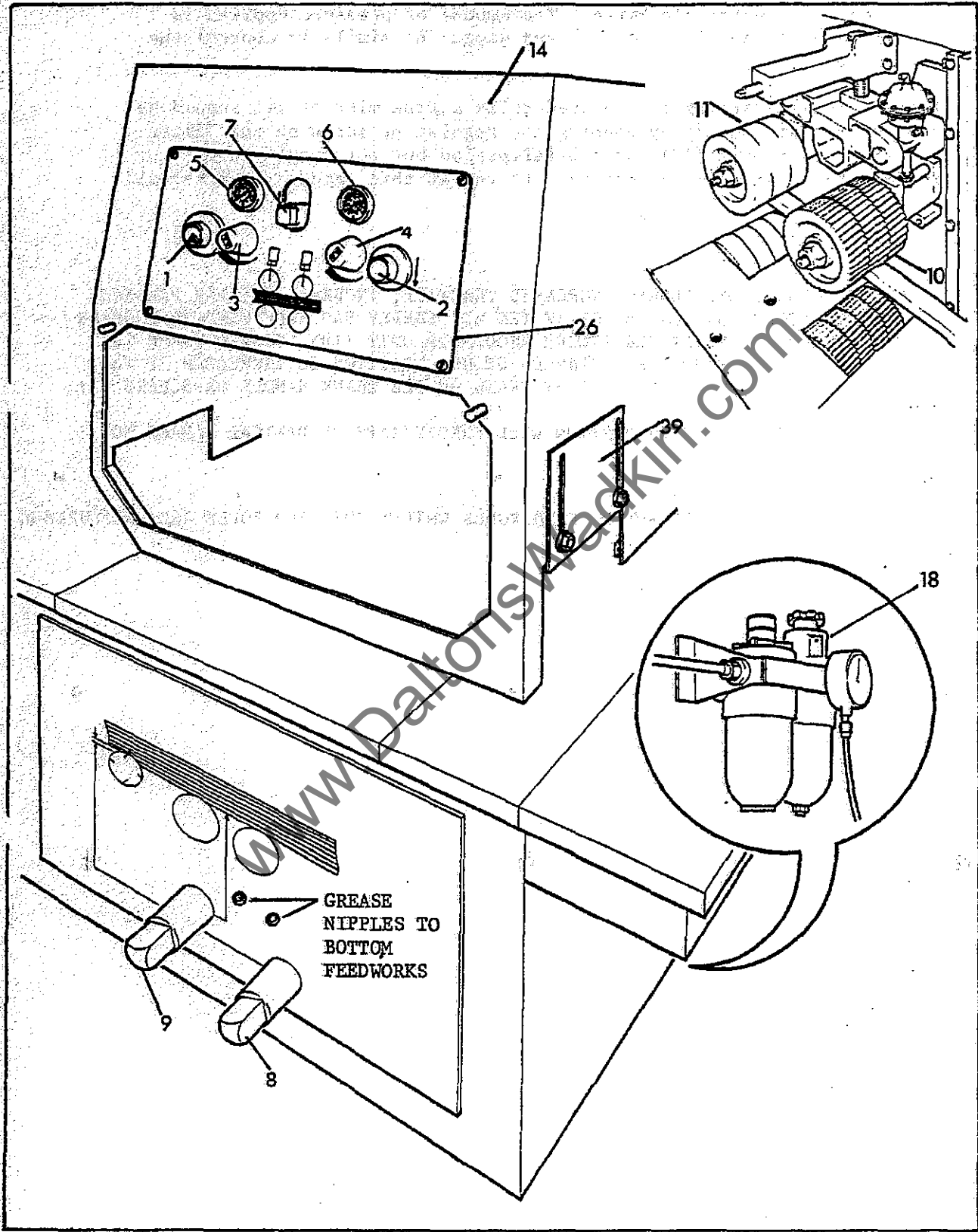

FRONT VIEW OF FEED WORKS WITH COVERS IN POSITION

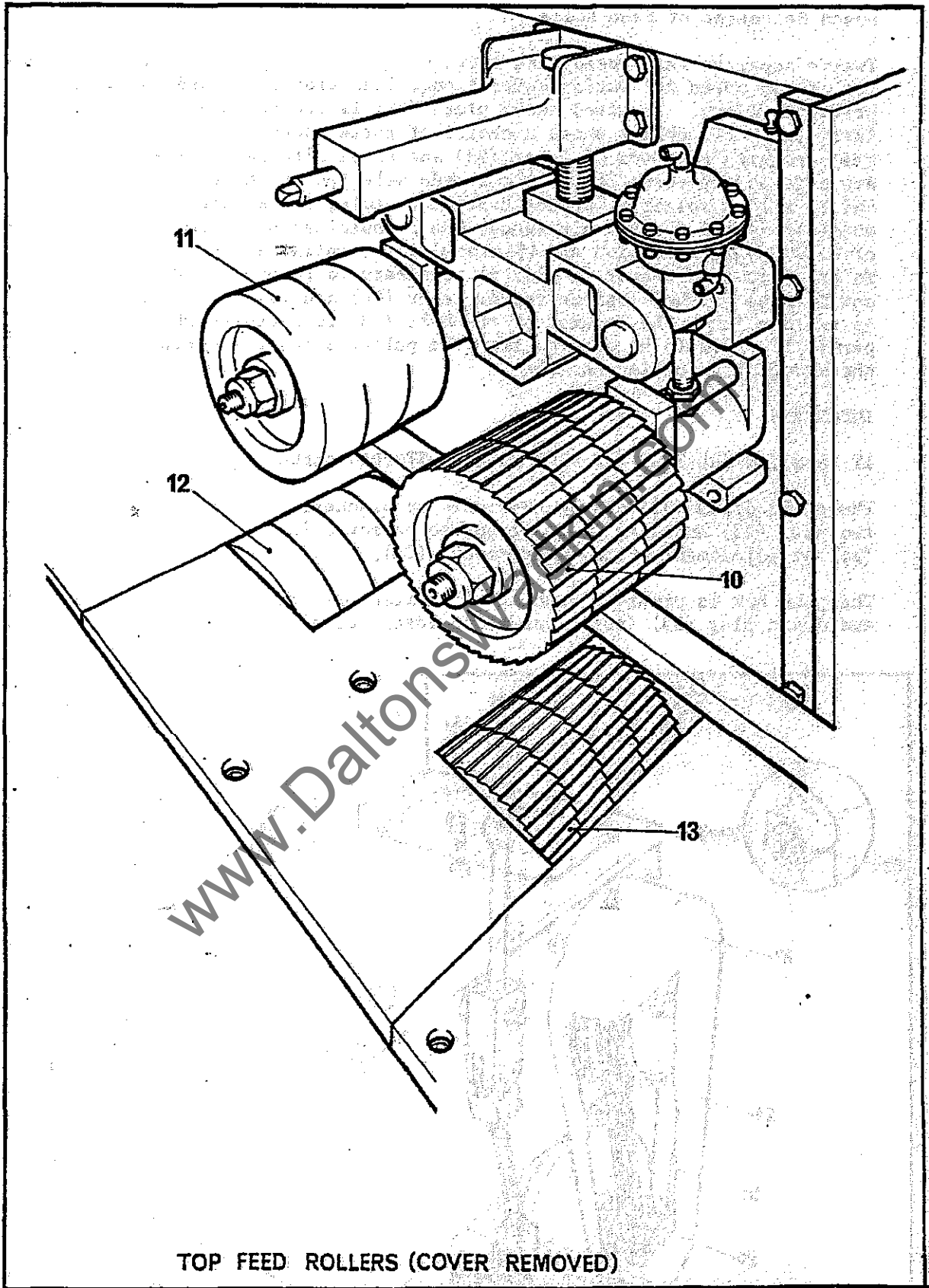

TOP FEED ROLLERS (COVER REMOVED)

FEEDWORKS

Speed Selection of Feed Rolls.

Twelve separate feed speeds are provided by the media of a three speed gear box, a two speed 2:1 ratio squirrel cage induction motor and two step driving pulleys. The feed speed plate (29) is located near to the gear lever (23). To change speed a choice of three speeds is obtained by gear changing by means of lever (23) and three alternative speeds are obtained by retention of the speeds selected by the gear lever and by switch selecting at the control console, the alternative motor speed. A further six speeds can be obtained by a combination of motor speed selection and by changing the pulley sheave ratios. To put this into effect it will be necessary to remove the guard (27) and operate the belt change toggle lever (24) and release locknuts (30) so as to release the tension of the belt (28) to a degree which will permit the belt to be removed from the pulley sheaves and replaced on the alternative pulley sheaves.

IMPORTANT:

IT IS ESSENTIAL THAT THE FEED MUST BE STOPPED BEFORE CHANGING SPEED.





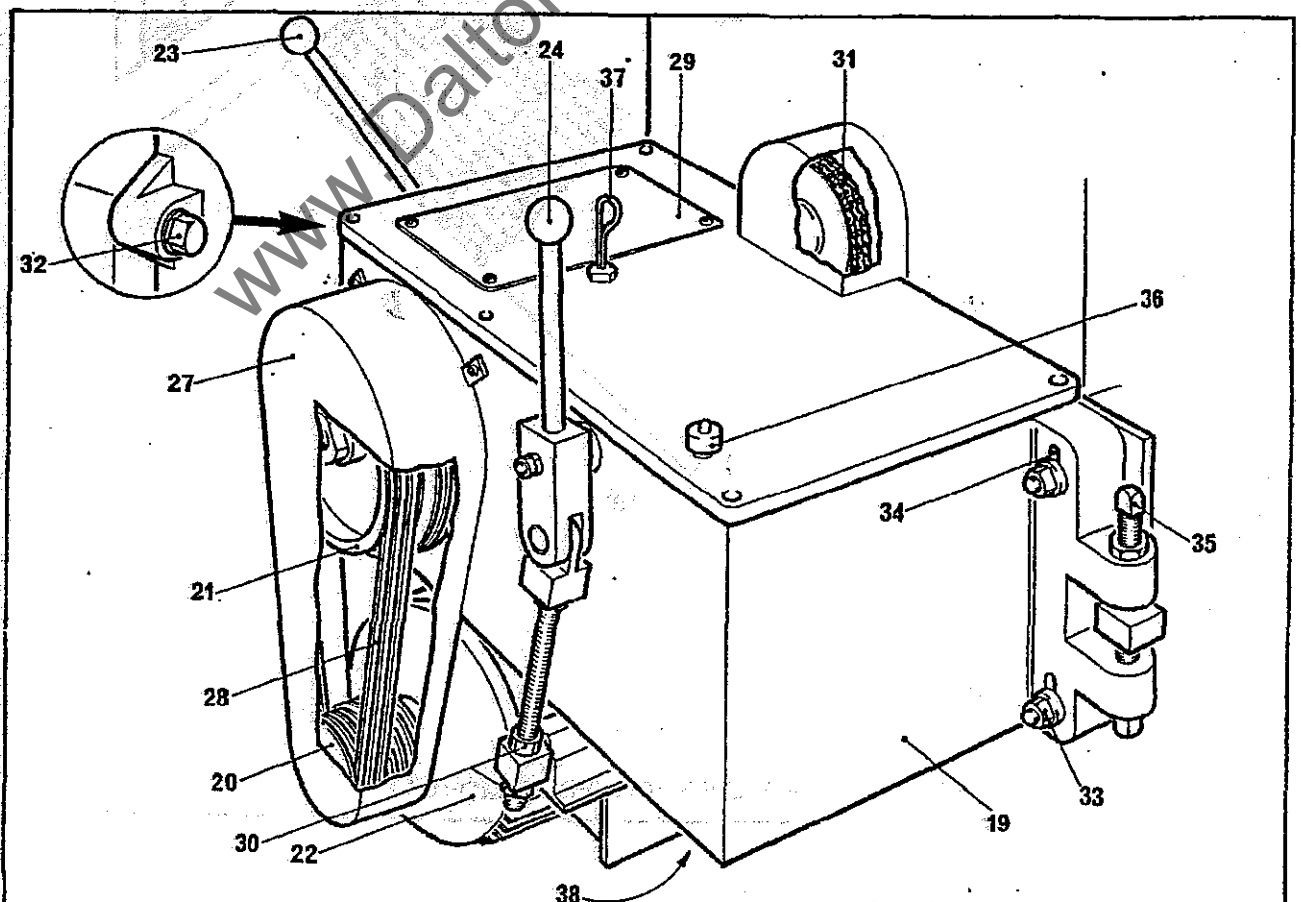



The chain drive (31) can be tensioned by slackening off bolt (32) and two nuts (33) enabling the gear box to be moved in the elongated slots (34) by adjustment of the jack screws (35).

The gear box is provided with an oil filler/cum breather (36) dipstick (37) and drain plug (38) (see lubrication instructions)

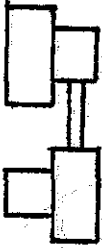

REAR VIEW OF ENCLOSED FEEDWORKS SHOWING GEARBOX AND PULLEY DRIVE

DALE DIVISION DALTONS WADKIN

	I 		II 		
					
	20 6	30 9.2	40 12	60 18.4	FEET / MIN METRES / MIN
	45 13.7	65 19.8	87 26.5	130 39.6	
	50 15.2	75 22.9	100 30.4	150 45.8	

www.DaltonsWadkin.com

FIRST BOTTOM HORIZONTAL HEAD

Vertical adjustment of the First Bottom Horizontal Head is made by applying a crank handle to the square (1). The nut (2) is the lock for this movement. To loosen or tighten the nut will necessitate the employment of a spanner. Access to the locking nut is via door (2a).

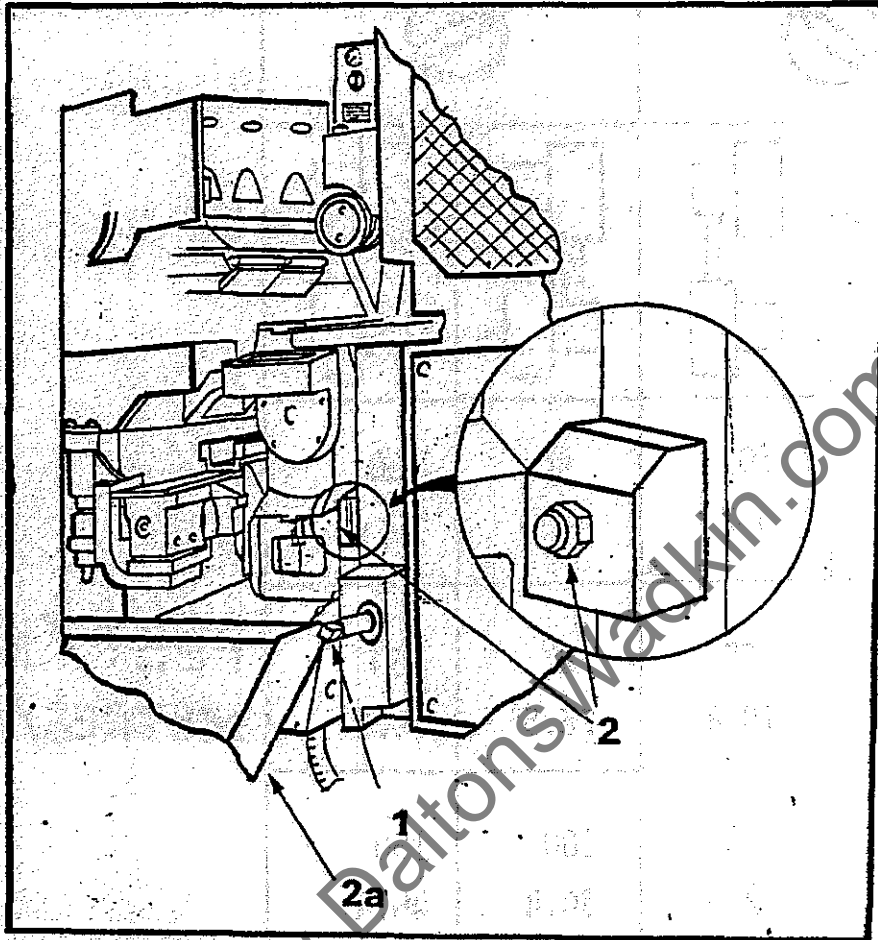

Horizontal adjustment is made by means of square (3). Locking lever (4) is the lock for this movement.

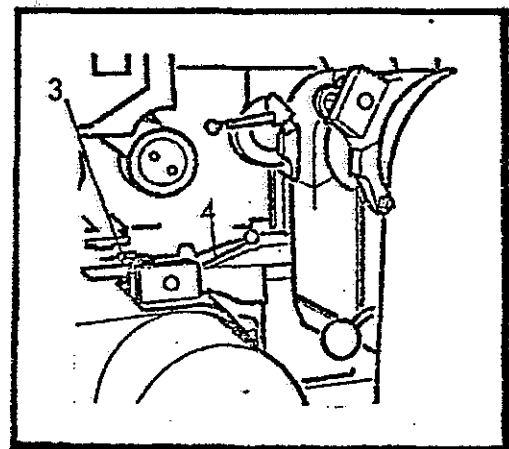

TOP HEAD AND CHIPBREAKER

Vertical adjustment of the top head is made by applying a crank handle to the square (1). Nut (2) is the lock for this movement.

Horizontal adjustment is made by square (3). Locking lever (4) is the lock for this movement.

The chipbreaker hood can be swung back for access to the cutterblock by lifting handle (5). The hood is held back by pushing in shaft (6).

The chipbreaker may be set in one of three positions (relative to hood) for different cutterblock diameters. Stud (7) locks the chipbreaker in position.

The chipbreaker hood may be adjusted in the vertical from a stud and locking 'nut' at the rear of the chipbreaker.

Chipbreaker shoes are independently spring loaded.

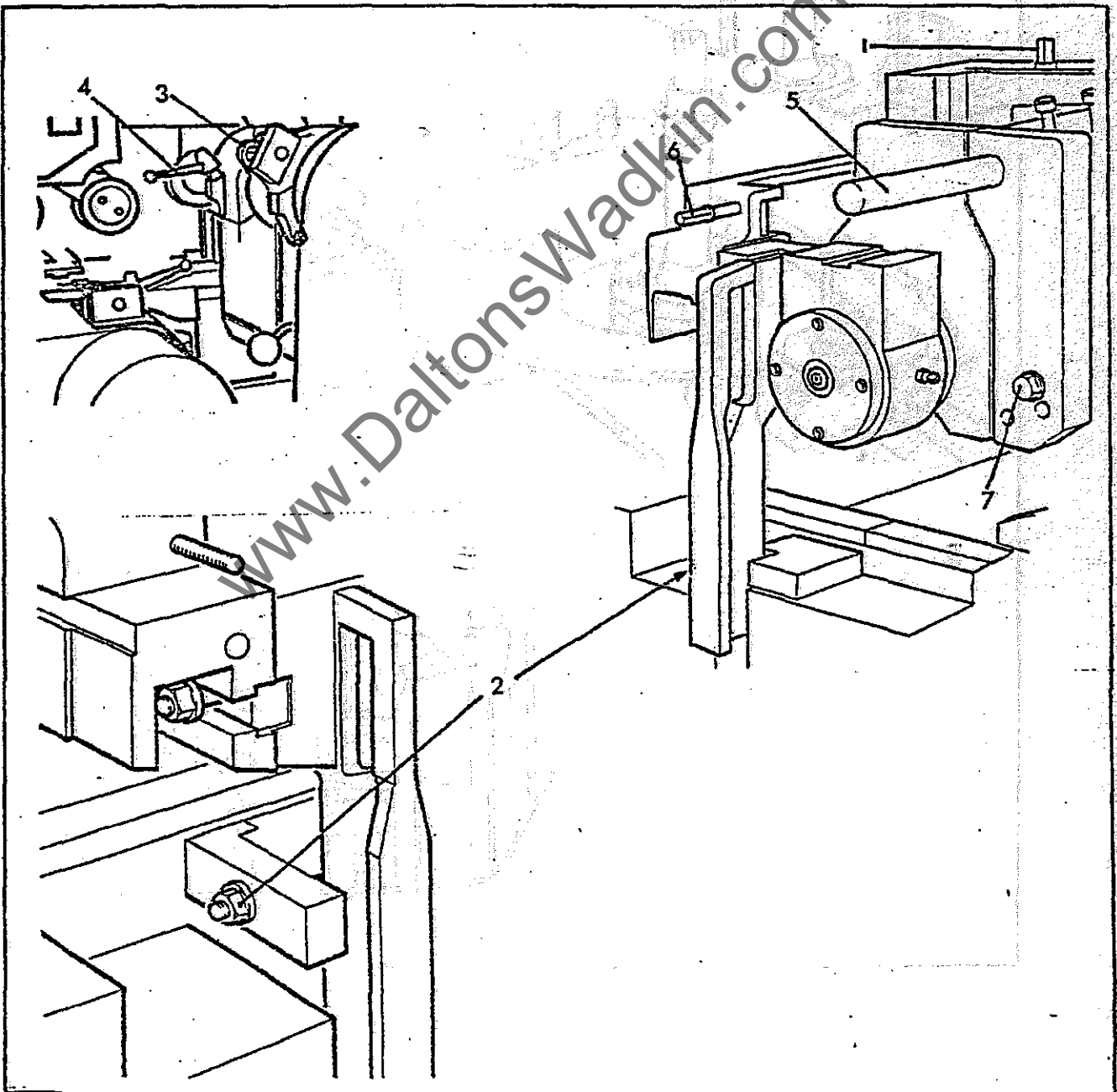

FENCE SIDE HEAD

Horizontal adjustment of fence side head is made by applying a crank handle to square (6) at front or rear of machine. Nut (7) is the lock for this movement.

Vertical adjustment of fence side head is made by means of a square (8). Nut (9) is the lock for this movement.

The bedplate may be adjusted to allow for larger cutting circles by slackening off two locking handles (10) (underneath the carriage from front of machine) and sliding plate by hand.

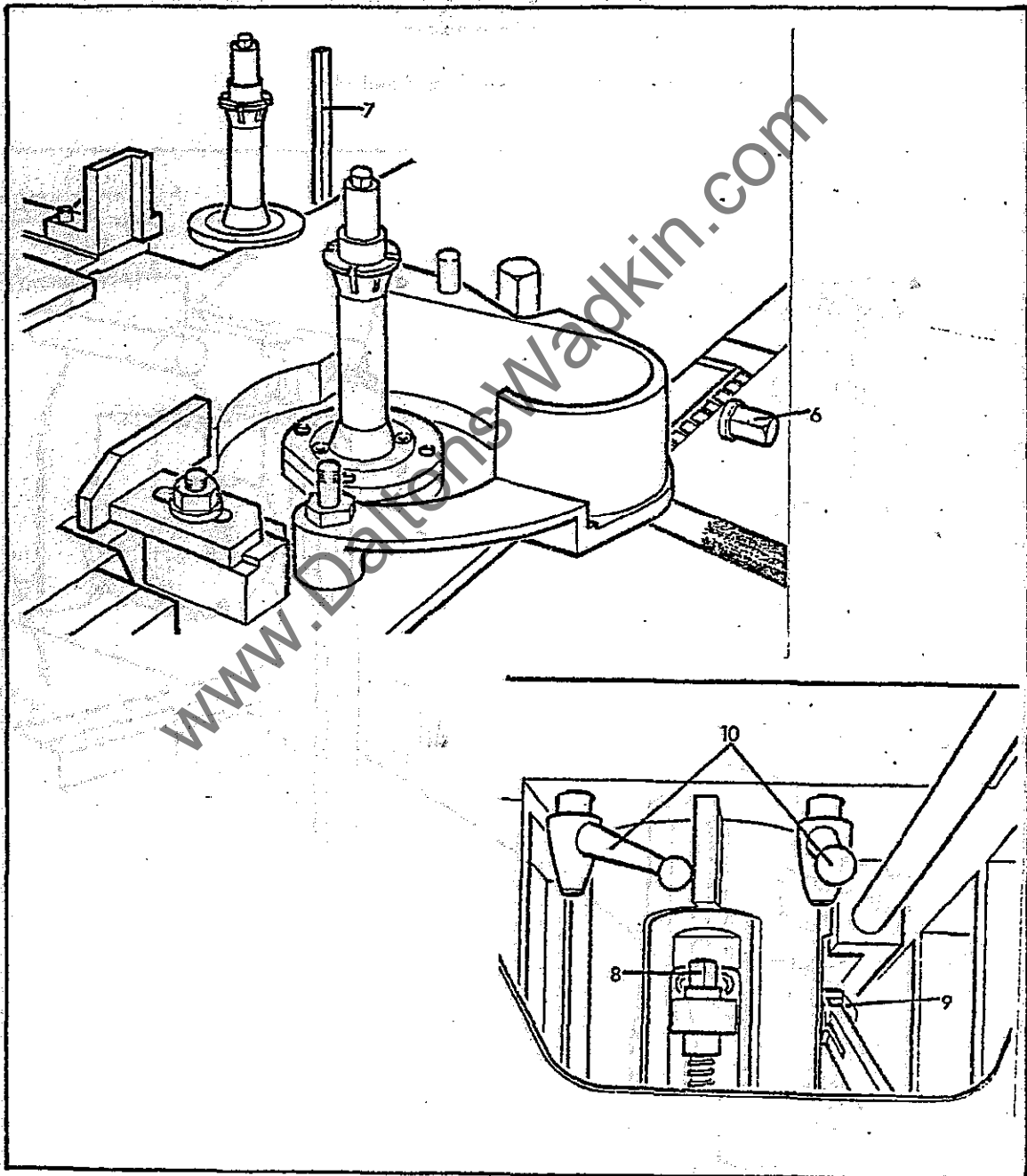

SIDE HEADS

Near Side Head

Horizontal adjustment of near side head is made by means of a crank handle on the square (1). Nut (2) is the lock for this movement.

Vertical adjustment of near side head is made by means of a square (3). Nut (4) is the lock for this movement.

The bedplate may be adjusted to allow for larger cutting circles by slackening off two locking handles (5) (underneath the carriage at the rear of the machine) and sliding plate by hand.

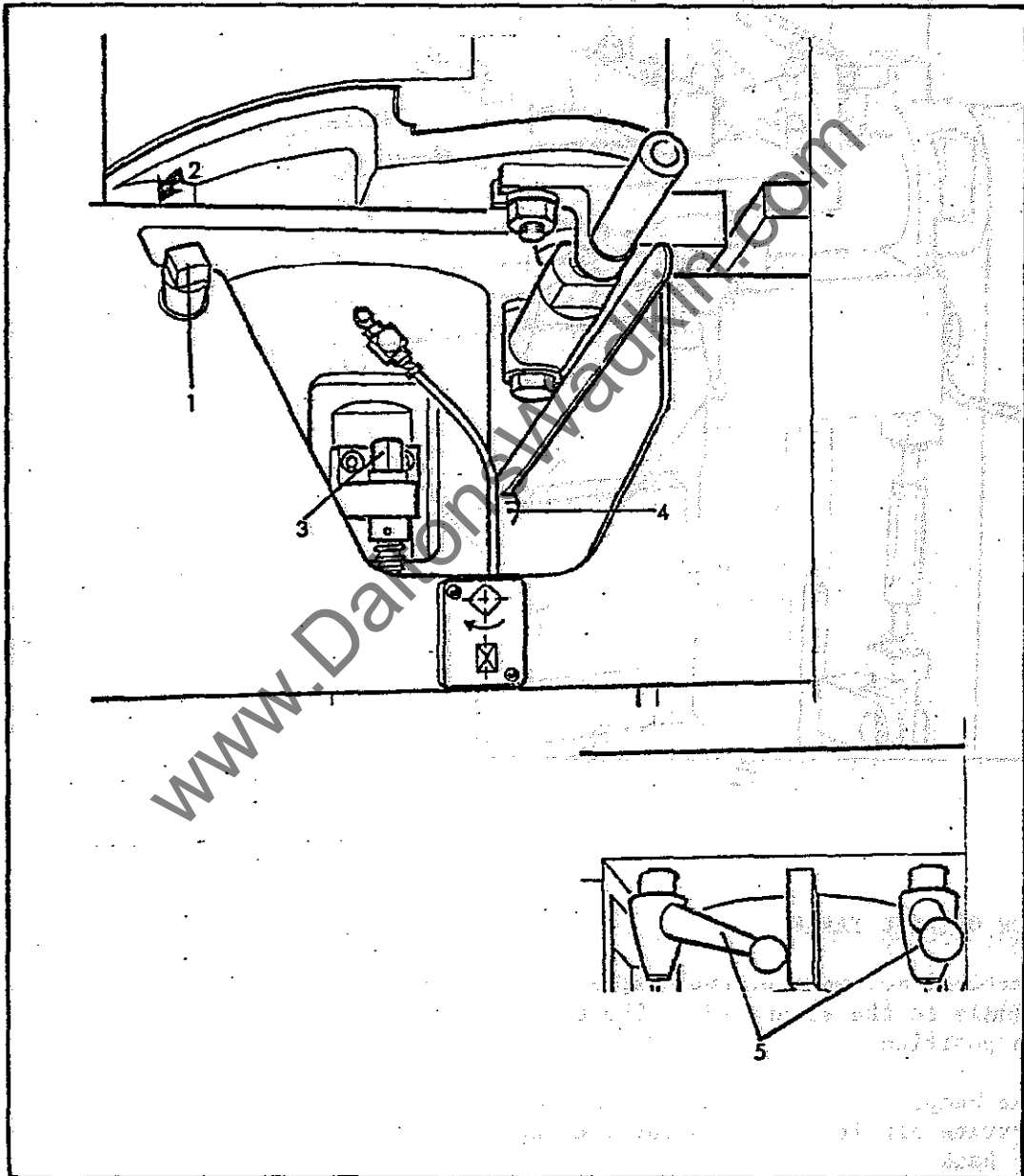

SECOND BOTTOM HEAD

Horizontal adjustment of the second bottom head is made by square (1). Locking lever (2) is the lock for this movement.

Vertical adjustment of the bottom head is made by applying a crank handle to square (3). Locking lever (4) is the lock for this movement. (Similar adjustment to the first bottom head).

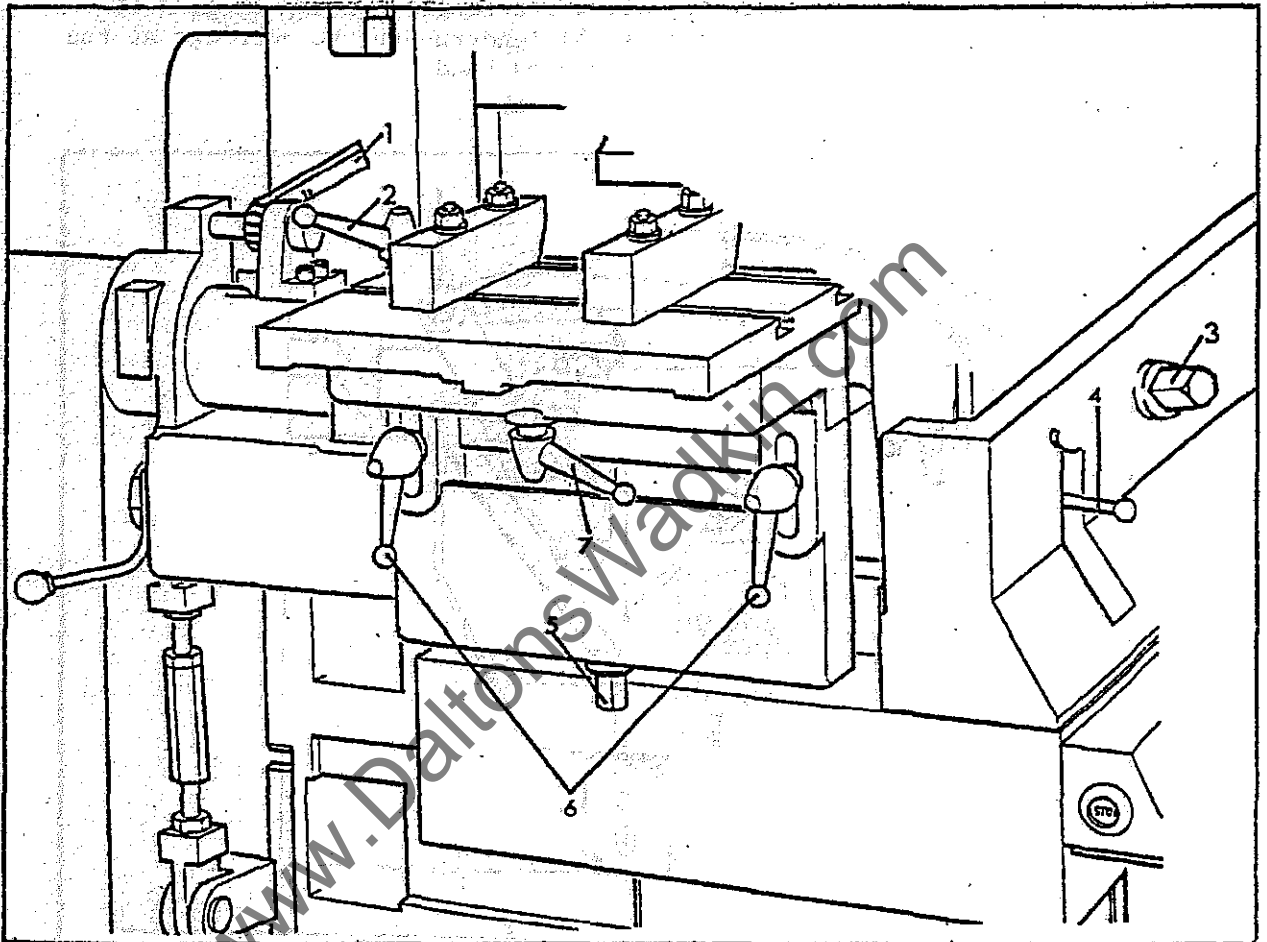

THE OUTFEED TABLE

Vertical movement of the outfeed table is made by applying a loose ratchet handle to the square (5). The two locking levers (6) lock the table slide in position.

The bedplate on the outfeed table may be moved out to accommodate larger cutting circles by releasing locking handle (7) and sliding the bedplate by hand.

HORIZONTAL HEAD DRIVES (BELT)

To change speed, lift handle (1). This raises the motor and allows belts to be changed. Lower handle back to original position after changing speed.

To tension belts, rotate turnbuckle (2). This is locked with locknut (3).

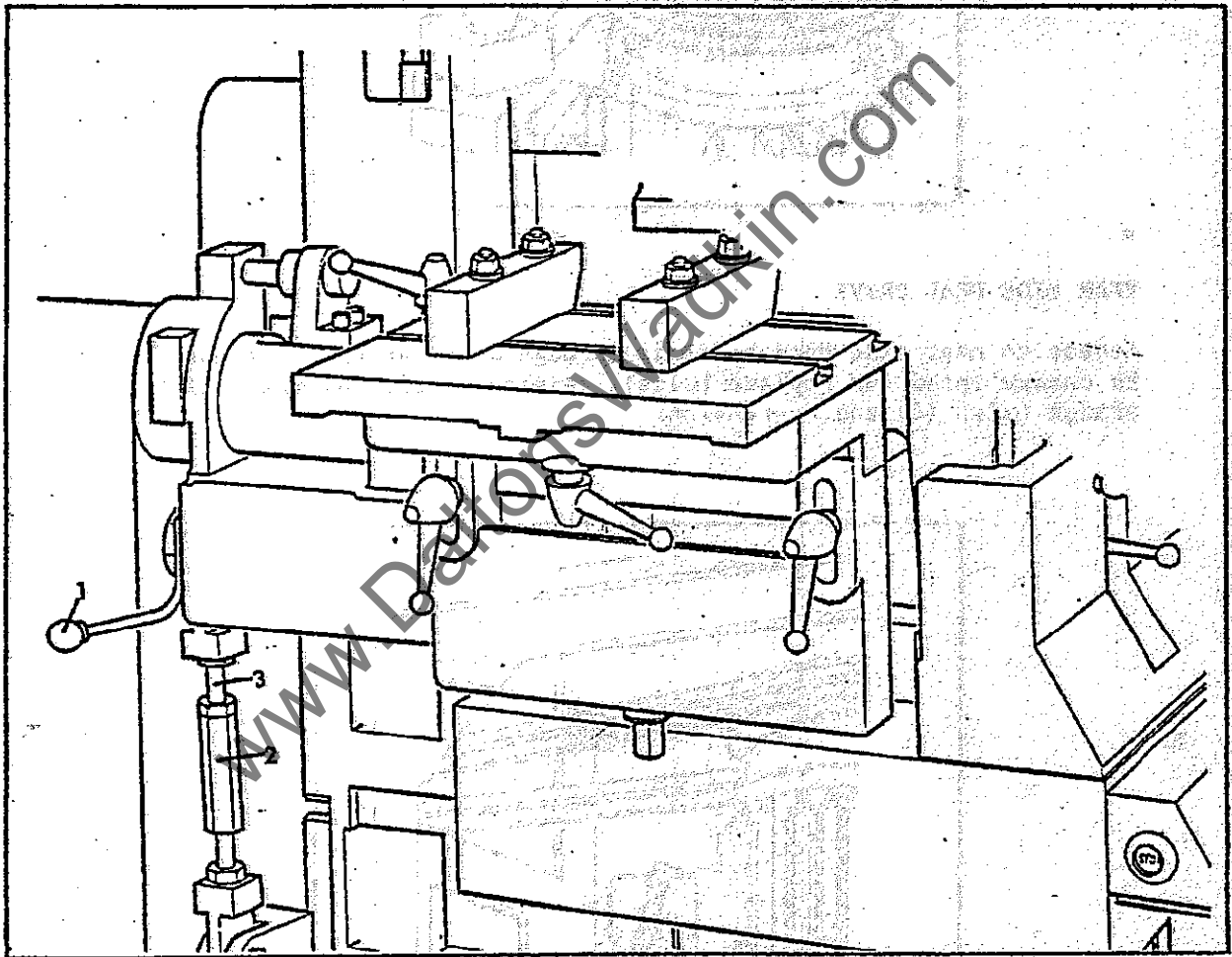

SIDE HEAD DRIVES (BELT)

FENCE SIDE HEAD DRIVE

To change (or replace belts), remove cover, release tension via square (1), change belts (2) and re-tension.

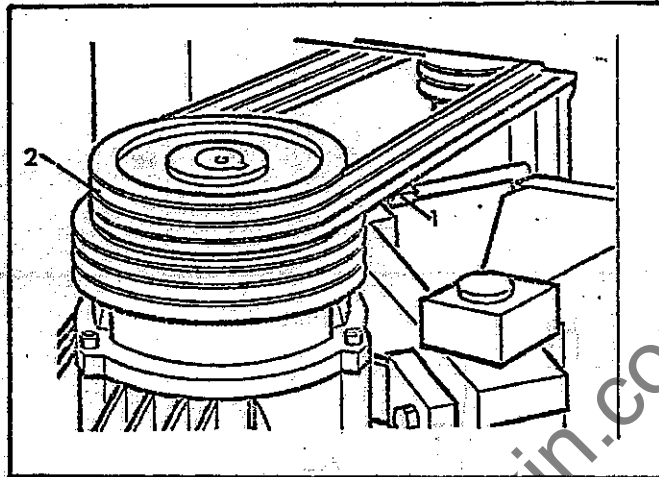

NEAR SIDE HEAD DRIVE

Access to near side head belts is through doors at front of machine. To change speed (or replace belts), release tension by means of knob (3), change belts (4) and re-tension.

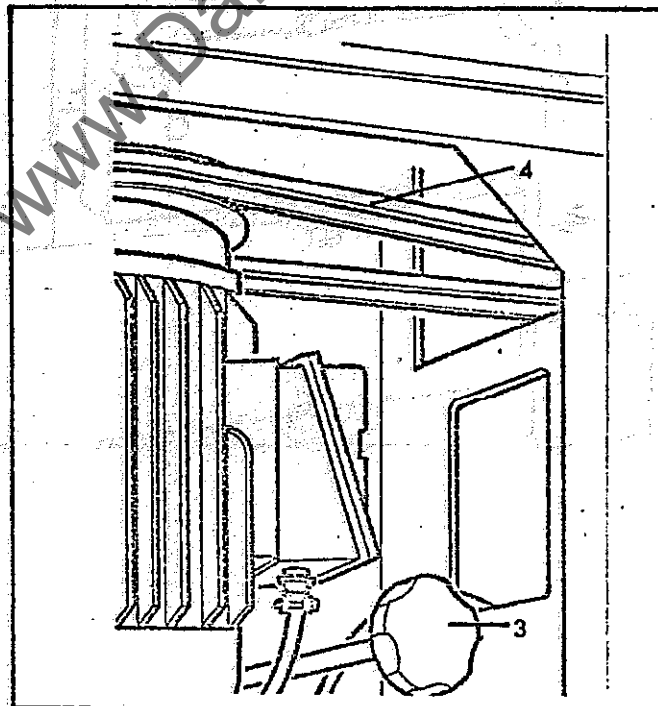

NEAR SIDE HEAD CHIPBREAKER

The chipbreaker may be set in one of two positions, to allow for different cutting circle diameters, by repositioning locking screw (1).

The dust hood is removed by lifting from locating pins (2).

Handle (3) can be swung sideways, (in the direction of arrow) by releasing nut (4). This allows the chipbreaker mechanism to be swung clear of the block.

No adjustment to spring pressure is required, releasing locknut (5) enables adjustment of the chipbreaker position to be made by knurled handle (3).

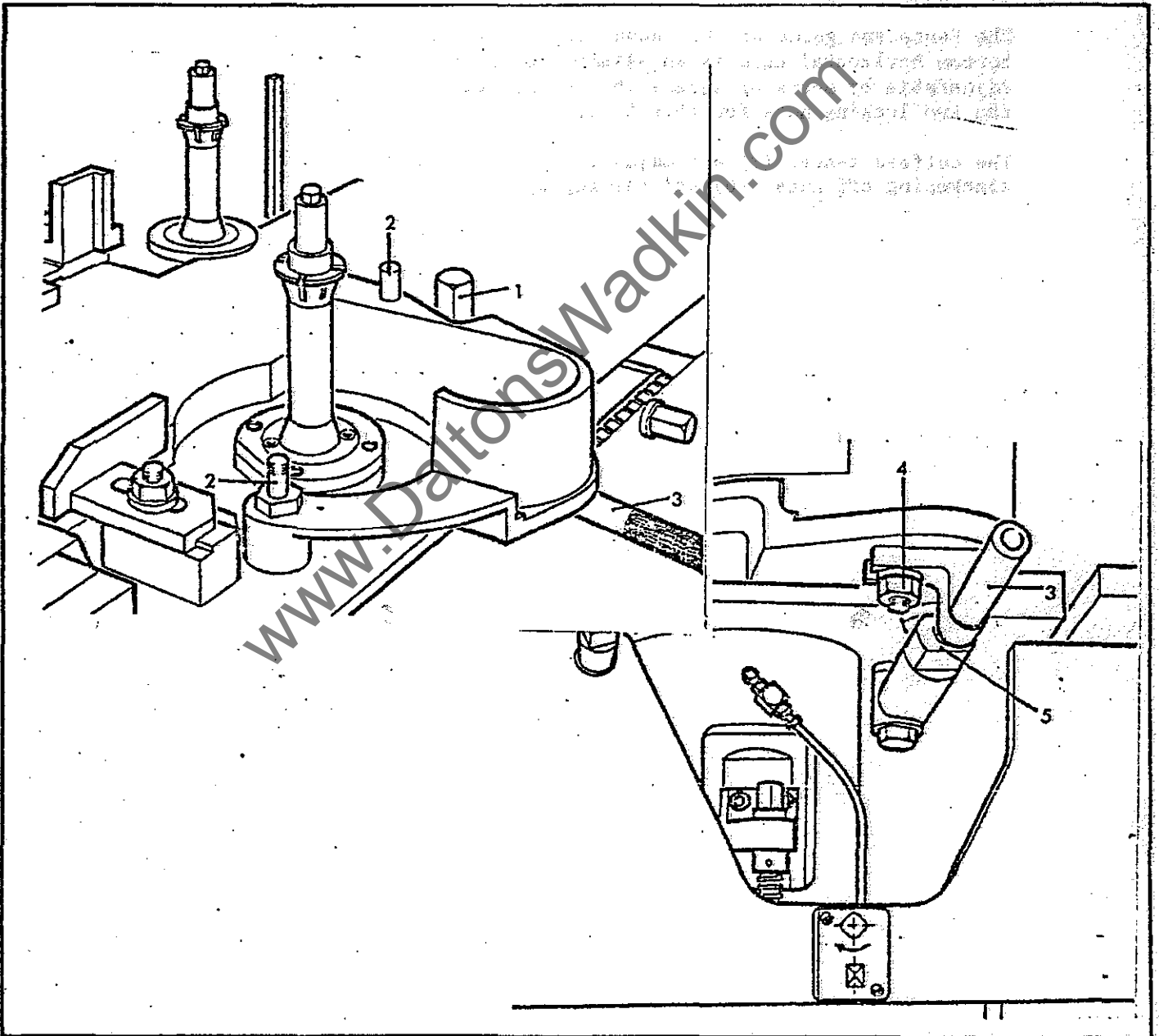

FENCES AND TIMBER GUIDE

The infeed fence (1) is fixed and requires no adjustment.

The fence (2) under the first top horizontal head is also fixed and requires no adjustment.

A timber guide (11) is provided immediately after the near side vertical head. Transverse adjustment relative to the near side head (to cater for different cutting circle diameters) can be achieved by slackening off nut (12) and sliding by hand.

The fence shoes (3) located either side of the fence side head are adjusted by slackening off nuts (4) and sliding by hand. This is to allow for variation in cutting circle diameters.

The fence and guide at the second top horizontal head and before the second bottom horizontal head is an assembly of parts (5) and (13). This is adjustable by means of square (6) at the rear of the machine. (7) and (8) are the two locking nuts for this fence.

The outfeed fences (9) are adjustable both laterally and transversely by slackening off nuts (10) and sliding by hand.

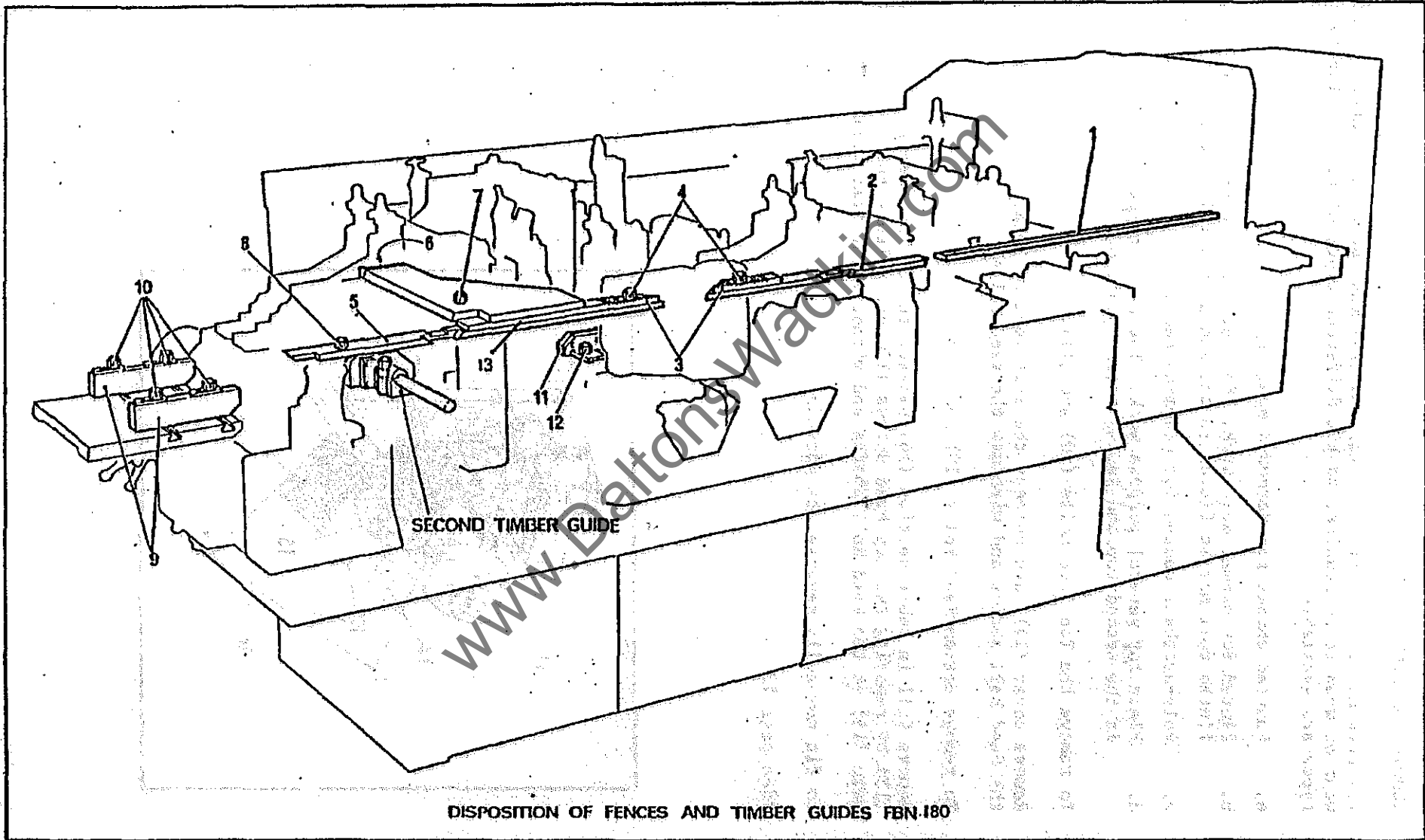

DISPOSITION OF FENCES AND TIMBER GUIDES FBN-180

REMOVAL OF FEED ROLLS

The Feed Rolls (10), (11) or (12) and (13) must be removed after excessive wear or when it is required to fit different types of rolls. The following types are available.

- a. Knurled chrome for Hardwood Mouldings.
- b. Fluted for normal duty work. For heavy duty work a second fluted roll may be fitted in the second top roll position.
- c. Poly-urethane coated for pre-machined work
- d. Plain for general purpose work. These are normally fitted in the second top and second bottom position.

To remove the Top Feed Rolls (10) and (11).

Remove cover (14)* and release the self locking retaining nuts (15) at the Feed Roll shafts and withdraw the feed rolls.

To remove Bottom Feed Rolls (12) and (13).

Remove fill in table section (16) between the bottom feed rolls (12) and (13) by removing two cap head screws (17) and release the self locking nuts (15) at the Feed Roll Shafts and withdraw the feed rolls.

To fit new rolls reverse the procedure.

*See page 13

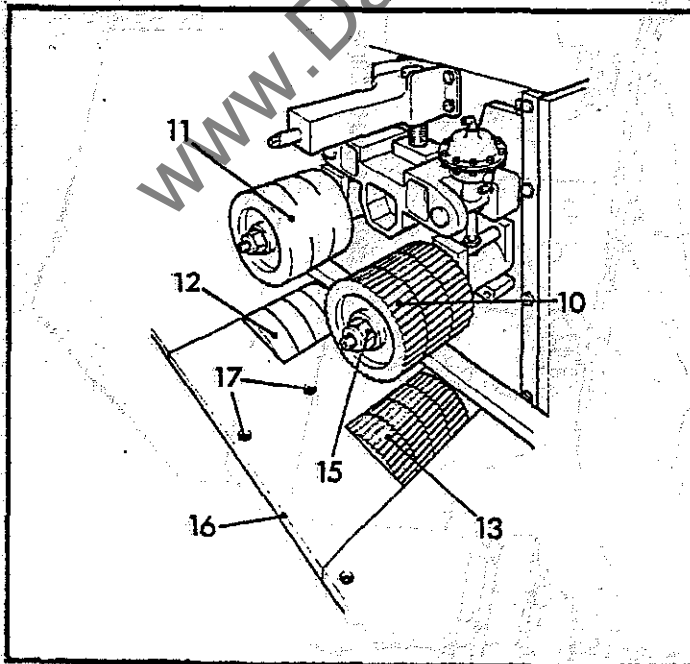

TOP PAD PRESSURE

The pad pressures (1) are all interchangeable on both the square bar mounting and the chipbreaker support mounting.

The main vertical adjustment when the pressure is mounted on the square bar is by means of the square (2) on top of the beam. The square (2) also provides the means for fine vertical adjustment. Nut (3) is the lock for this movement. The pad can be adjusted laterally about the elongated slots (4) and locked in position by nut (5).

The side timber guide (7) adjustment is made by slackening off the nut (8) and sliding the pressure along the cylindrical bar (6).

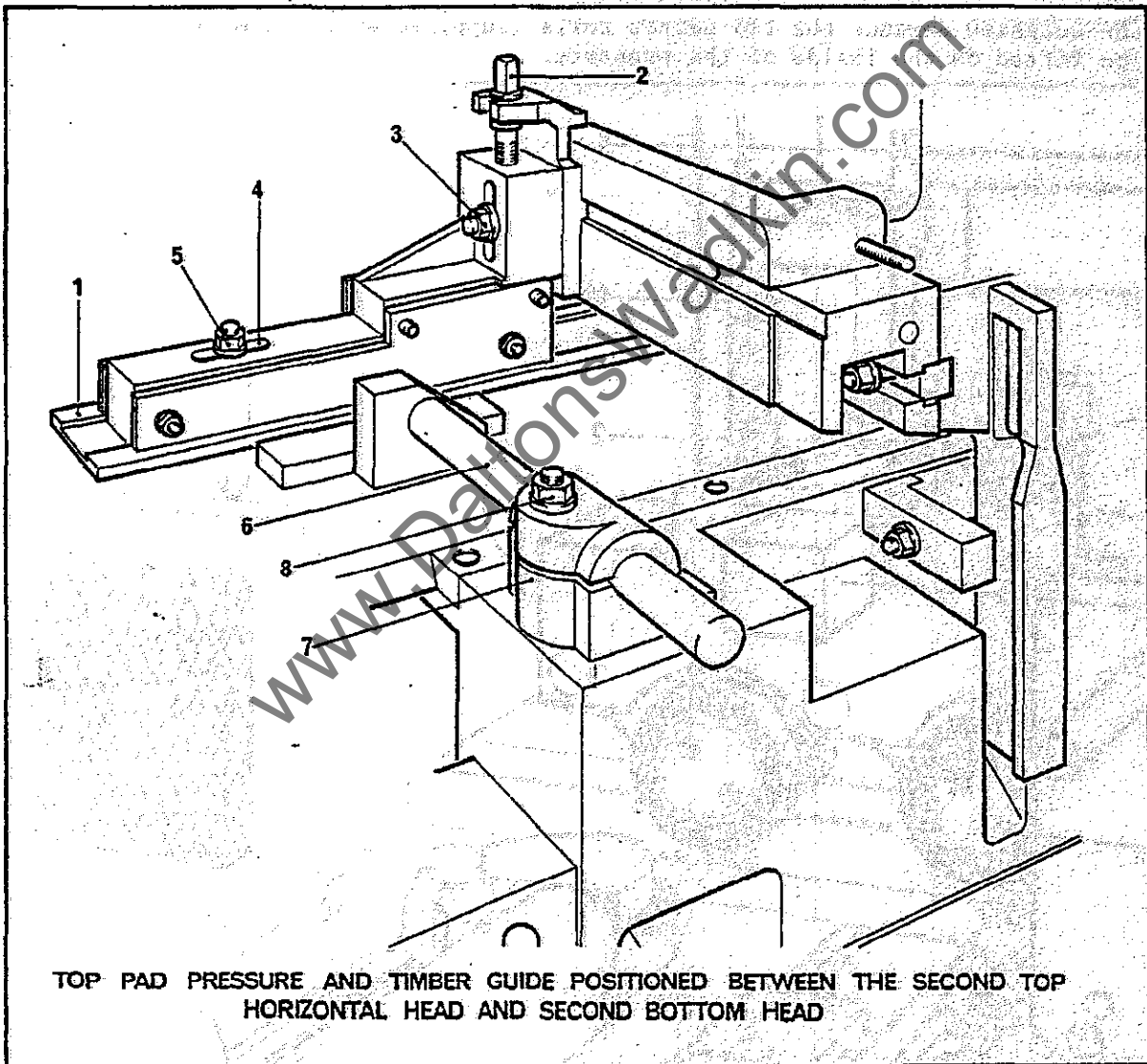

TOP ROLLER PRESSURE

The vertical adjustment of the top roller pressure (12) is by means of applying a crank handle on square (1). Nut (3) is the lock for this movement.

The horizontal adjustment of the roller pressure is made by slackening off nuts (6) and sliding the pressure by hand along bar (7). The spring pressure applied to each roller can be adjusted by means of screws (2) and (5)

NARROW STOCK

When cutting narrow stock it may be necessary to remove the outside roller from the pressure. To achieve this it will be necessary to remove the capscrews (4) this will enable side pressure access to the timber.

If the occasion demands the two narrow rolls (supplied with the machine) can be fitted on the inside of the pressure.

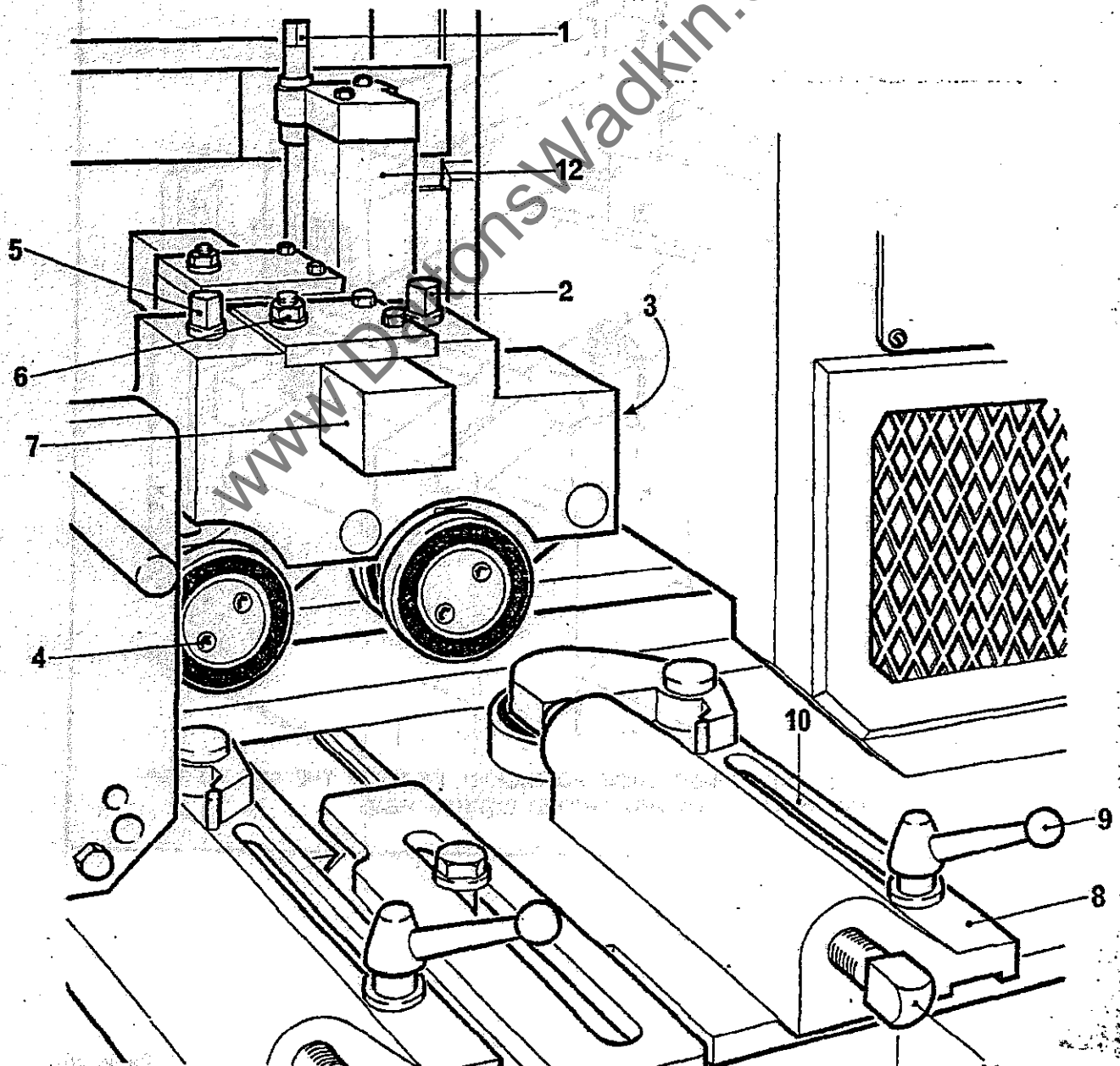

SIDE PRESSURES

Three front roller pressures (8) are usually supplied with the machine. To cater for different widths of timber adjustment is effected by slackening off locking lever (9) and sliding the pressure (8) by hand about the elongated slot (10). A series of holes is provided across the bed. Locking lever (9) should be used in the most suitable hole. The spring pressure applied to the roller can be adjusted by means of screw (11).

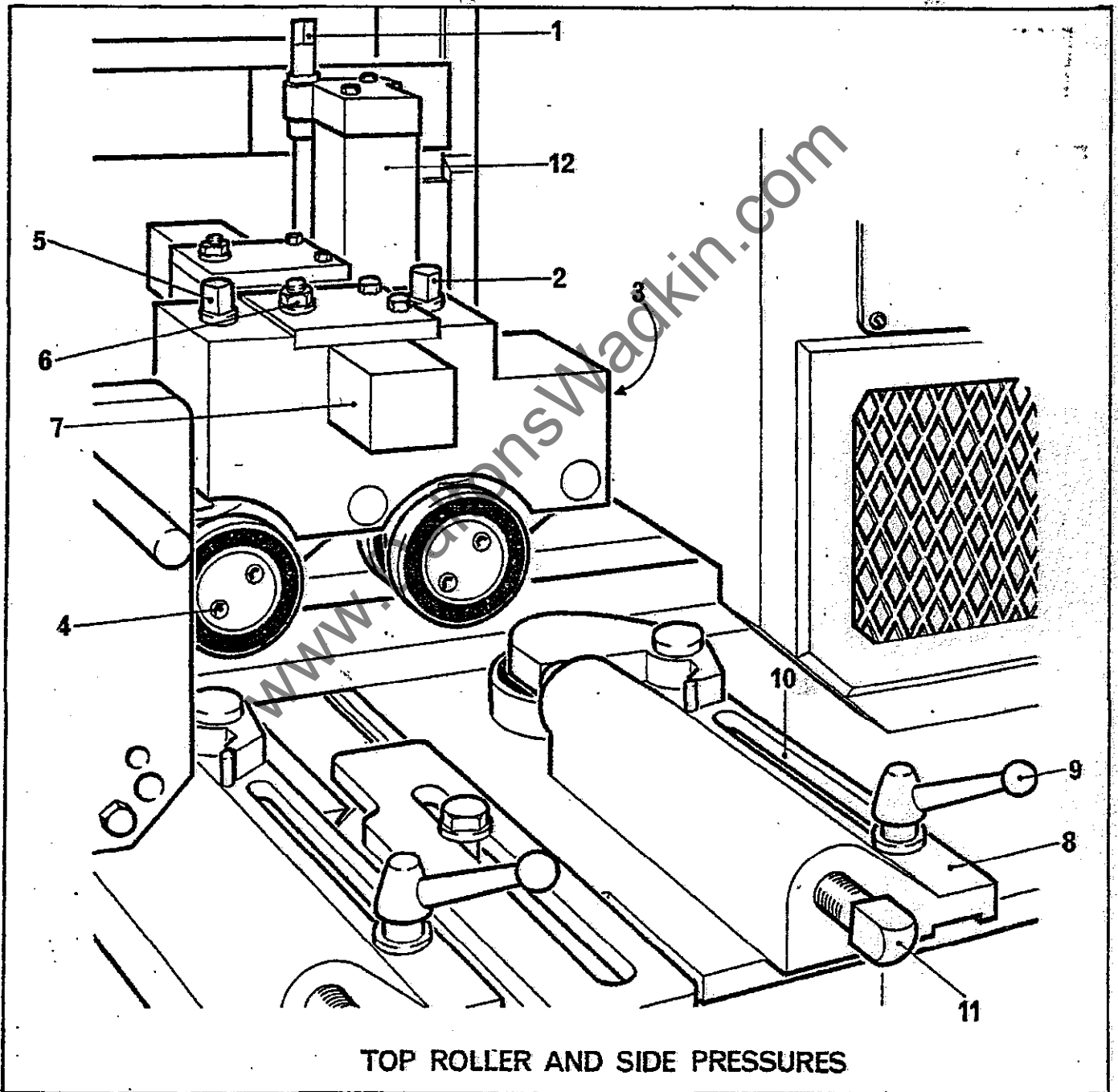

FENCES AND TIMBER GUIDE

The infeed fence (1) is fixed and requires no adjustment.

The fence (2) under the first top horizontal head is also fixed and requires no adjustment.

The fence shoes (3) located either side of the fence side head are adjusted by slackening off nuts (4) and sliding by hand. This is to allow for variation in cutting circle diameters.

The fence (5) under the second top horizontal head is adjustable by means of square (6) at the rear of the machine. The two nuts (7) and (8) are the locks for this fence.

The outfeed fences (9) are adjustable both laterally and transversely by slackening off nuts (10) and sliding by hand.

A timber guide (11) is provided immediately after the near side vertical head. Transverse adjustment relative to the near side head (to cater for different cutting circle diameters) can be achieved by slackening off nut (12) and sliding by hand.

A second timber guide (6) (see page 31) is positioned between the second top horizontal head and the second bottom horizontal head. This can be adjusted transversely by slackening off nut (8) and sliding by hand through mounting bracket (7).

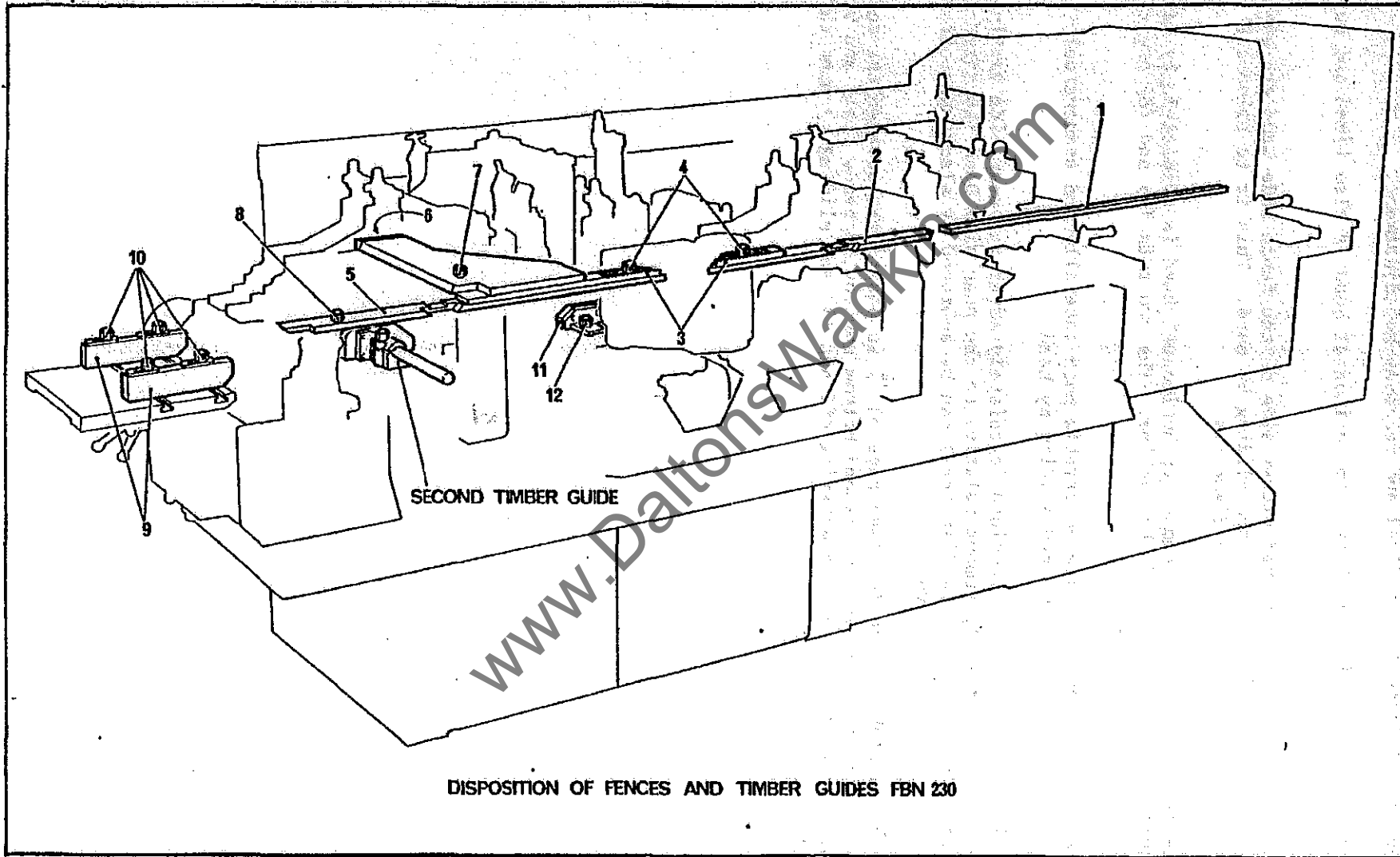

DISPOSITION OF FENCES AND TIMBER GUIDES FBN 230

PREPARATORY STEPS TO MACHINING FBN 230

Having knowledge of the dimensions of the finished workpiece the following sequential procedures should take place.

1. Set the section of fence which extends from the fence side head to the outfeed table. The setting should allow for the appropriate amount of timber removal by the fence side head. The method of setting is outlined on page 30 and page 31.
2. Adjust the fence side head to bring the cutting circle in line with the outfeed fence. Adjust the table to within 3 to 6mm (1/8in. - 1/4in.) in front of the cutting circle. The method of setting is outlined on page 19.
3. Set the fence gap at the fence side head to clear the cutting circle by adjusting the fence shoes located on each side of the fence side head. The method of setting is outlined on page 20.
4. Set the vertical position of the infeed table section between the feed rolls and the first bottom head. The setting should coincide with the amount of timber to be removed by the first bottom head. Adjustment is via the square (9) lock in position following adjustments. See page 13.
5. The bottom feed roll should be adjusted to be 0.8mm (1/32in.) proud of the table by handle (8). 'Rough timber requires a greater projection' See page 13.
6. The bottom head cutter block should be adjusted so that the cutting circle is level with the outfeed table and the cutterblock is laterally adjusted to be 3mm (1/8in.) behind the rear fence line.
7. Set the clearance of the stock gate (39) at the infeed so as to clear incoming material by 6mm (1/4in.) See page 13.
8. The first top head should be set to machine the required thickness. Vertical adjustment is via square (1) and locking nut, (4). Lateral adjustment of cutter head is via square (6) and locking lever (7) and should be adjusted to be 3mm (1/8 in.) behind the rear fence line. See page 18.
9. The first top head chipbreaker shoes should be set for clearance to the cutting circle of the block and can be set to any one of three positions by stud (13) see page 18.
10. Chipbreaker shoes should rest on the timber with approximately 3mm (1/8in.) depression.
NOTE: A JACKING SCREW IS PROVIDED ON THE REAR OF CHIPBREAKER HOOD TO RESTRICT DOWNWARD MOVEMENT OF THE HOOD ASSEMBLY.
11. Roller and pad pressures should be raised to permit free movement of timber for setting purposes and laterally adjusted to approximate positions for the timber to be machined.
12. The near side head should be set to machine the timber to the required width. Lateral movement via square (2) locknut (1). Adjust table to within 3-6mm (1/8in. - 1/4in.) of cutting circle locking levers, under bedway through rear aperture see page 20.

FBN 230

13. Near side head chipbreaker should be set by selection of one of the two positions by adjusting screw releasing the knurled handle locking nut and turn the knurled handle to align the chipbreaker shoes with the cutting circle.
14. Where second or third top heads are fitted set head and chipbreaker as in procedures 9, 10 and 11.
15. Where second bottom head is fitted the outfeed table is set level with the cutting circle using a straight edge and the table is moved in or out to provide minimum clearance to the cutting circle.
16. Adjust the vertical position of the head and outfeed table to gain the cut required, relative to the machine table.

www.DaltonsWadkin.com

MACHINING

1. Select a piece of timber to be machined, enter to the first feed roll allowing 6mm (1/4in.) clearance on the stock gate.
NOTE: (where air operated rolls are fitted there must be a clearance of at least 15mm (5/8in.) between the roll and the top face of the timber). Where hand adjustable rolls are fitted a suitable gripping pressure should be set on the timber.
2. Adjust the first side pressure on the infeed table up to the timber with no exerted pressure (clearance - this is a guide only) where short stock is run a similar side pressure should be mounted between the feed rolls.
3. Inch (Jog) forward the timber until it enters the first side pressure roller, then adjust in the roller to give 4mm (3/16in.) depression on the rollers.
4. Lower the first top roller pressure to 3mm (1/8in.) depression on the roller.
5. Start first bottom head cutterblock.
6. Inch (Jog) the timber through until it just causes the first top head chipbreaker shoes to lift.
7. Start first top head and inch (jog) timber through until it enters 50mm (2in.) under the following top pressure (pad).
8. Wind the pressure down to touch the timber. This pressure is spring loaded and should not be 'wound' down until solid.
9. Inch (jog) the timber through to the next side pressure (roller) or (shoe) and set 3mm (1/8in.) depression.
10. Start the remaining heads.
11. Inch (jog) to move the timber up to the back fence
12. Set second top pressure (first pad) to hold.
13. Inch (jog) timber through to end (back) of second pad pressure.
14. Wind down pressure to hold over the full length.
15. When a second top head is fitted Inch (jog) until the timber just causes the second top head chipbreaker shoes to lift.
16. Off up the near side fence to the approximate width of finished timber.
17. Inch (jog) through the timber until it enters 50mm (2in.) under the following top pressure pad.
18. Wind down the pressure to just touch the timber. This pressure is spring loaded and should not be 'wound' down until solid.
19. Inch (jog) through the timber approximately up to the last bottom head.
20. Reset pressure as in (21) to hold over the full length.

21. Set the outfeed side pressure to hold along the length.
22. Inch (jog) through timber to the outfeed table, run one complete piece and check dimensions.
23. If the finished piece of timber is not dimensionally correct adjust where necessary.

www.DaltonsWadkin.com

JOINTING

Jointers are provided to improve quality of finish by ensuring that all knives on a block are cutting equally.

Normally about five jointing operations can be obtained before a maximum heel of 1.1mm (.045 in.) is reached and the block is removed for regrinding.

The jointers can be divided into 4 types

- (1) Straight built-in jointer for first bottom head only
- (2) Straight jointer for horizontal heads.
- (3) Profile jointer for horizontal heads.
- (4) Combination (straight and profile) jointer for use on side heads.

www.DaltonsWadkin.com

PROCEDURES PRIOR TO JOINTING

On near side head, prior to jointing, the extraction equipment must be removed and chipbreaker mechanism swung clear.

In case of fence side, extraction hood only need be removed, shaft 'A' must be entered through the hole in the beam.

In both cases the slide is located on a spigot and locked down by means of two captive screws in base.

A turret (1) provides the means for both profile and straight jointing. To rotate the turret, unfasten the knob (2) sufficiently to release the plunger, after rotation re-tighten the knob (2) this enables the spring plunger to precisely locate the turret.

To facilitate straight jointing, a holder is provided for the flat stone which is mounted in the turret as shown above.

The turret can be raised and lowered by rotating the raise and lower screw from square (3). The lock for this movement is (7).

Fine adjustment can be made by rotating screw (4). Jointing stones are fed towards the block by rotating screw (6). Locking screws (5) are provided on both slides.

COMBINATION JOINTER FOR VERTICAL SIDE HEADS

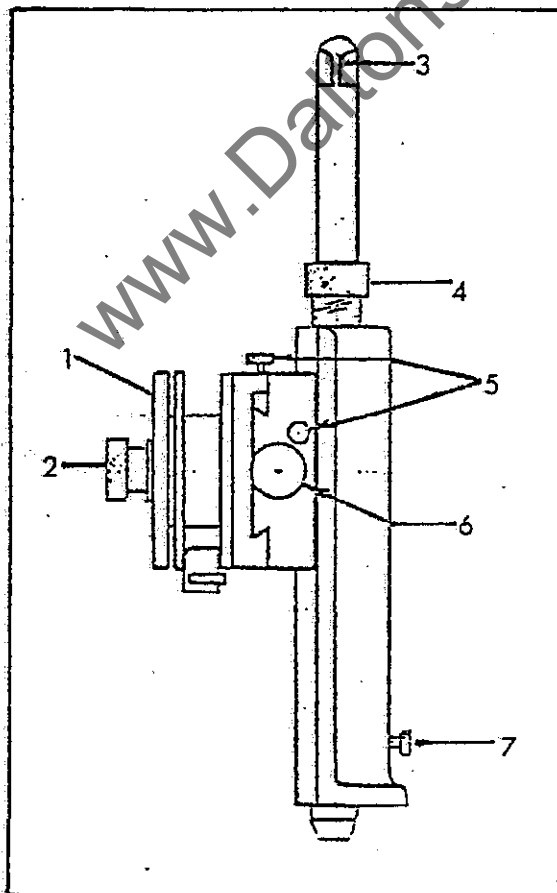

FIRST BOTTOM HEAD JOINTER WITH SCREW TRAVERSE

No. Off	Part No.	Description
2	K09 51 485	Enots straight adaptor - Female 341 0344 08
2	K09 50 109	Adams oiler 1/8in. B.S.P. - 90° LS 2630
1	K05 21 465	Black knob lin. dia. tapped 5/16in. whit. for FB 11434
10	K05 25 316	Hexagon socket countersunk screw M5mm dia. x 10mm long for FB 11427
1	FB 11427	Door hinge
1	FB 11426	Hinge mounting plate
2	K05 25 516	Hexagon head screw M8 dia. x 20mm long for FB 11426
2	K06 15 135	Needle bearing INA HK 4020
2	K06 16 72	Inner bearing race INA IR 35 x 40 x 20.5mm
1	FB 11412	End cap for needle bearing
1	FB 11443	Bracket for pivot shaft (front)
4	K05 25 210	Hexagon socket cap screws M10mm dia. x 30mm long for FB 11435 (2) and FB 11436 (2)
2	FB 11405	Slideway support bracket
3	K05 26 125	Hexagon socket cup point set screw M8mm dia. x 10mm long for FB 11405 (2) and FB 11406 (1)
2	K05 20 508	Taper pin No. 5 x 57mm long for FB 11405
1	FB 11435	Bracket for pivot shaft (rear)
1	FB 11413	Locating sleeve for needle bearing
1	FB 11407	End cap for plunger housing
3	K05 25 144	Hexagon socket cap screw M5mm dia. x 16mm long for FB 11407
1	FB 11417	Taper gib for slide
1	FB 11418	Gib adjusting screw
1	FB 11434	First bottom horizontal head door
1	FB 11432	Slideway for jointer
8	K05 25 309	Hexagon socket countersunk screw M4MM dia. x 10mm long for FB 11415 (4) and FB 11416 (4)
1	FB 11415	Retaining strip for slide
2	K05 25 212	Hexagon socket cap screw M10mm dia. x 40mm long for FB 11398
2	K05 25 518	Hexagon head screw M8mm dia. x 30mm long for FB 11444
1	NQ111M	Index plunger spring
1	FB 11422	Index plunger
1	FB 11444	Adjustment bracket
1	FB 11421	Cross adjustment screw
1	FB 11398	Lever for cross adjustment
1	FB 11408	Spring plunger
1	FD 7580	Plunger spring

HORIZONTAL STRAIGHT JOINTER WITH SCREW TRAVERSE

No. Off	Part No.	Description
1	FBJ 214	Jointer slide
1	FBJ 223	Jointer carriage
1	FBJ 228	Stone holder slide
1	FBJ 224	Screw bush plate, rear, screw traverse drop on jointer
1	FBJ 70	Stone clamp plate
1	FBJ 158	Knob for raising screw
1	FBJ 159	Raising screw for stone holder slide
1	FBJ 203	Screw bush plate, front, screw traverse drop on jointer
1	FBJ 215	Raising nut
1	FBJ 216	Gib strip for slide
1	FBJ 217	Gib strip for carriage
1	FB 12859	Square end for traverse screw
1	FBJ 219	Square end for traverse screw
1	FBJ 86	Straight jointer stone
2	K05 27 109	M8 x 5 thick hexagon thin nuts for FBJ 159
4	K05 27 108	M6 Hexagon thin nuts for FBJ 223
2	K05 27 112	M16 x 8mm thick hexagon thin nuts for FBJ 213
6	K05 26 116	M6 x 16 long hexagon socket screws cup point 4 for FBJ 223, 2 for FBJ 228
1	K05 31 526	Dia. 16 x 12mm I/D x 12mm long bronze oil retaining bush for FBJ 224
1	K05 20 480	Dia. 4mm x 12mm long tension pin for FBJ 158
1	K05 31 320	Dia. 18mm o/d x 12mm i/d x 12mm long flanged bronze oil retaining bush for FBJ 203
2	K05 25 167	M6 x 25mm long hexagon socket cap screws for FBJ 203
2	K05 25 170	M6 x 40mm long hexagon socket cap screws for FBJ 205
2	K05 25 145	M5 x 20mm long hexagon socket cap screws for FBJ 215
6	K05 25 142	M5 x 10mm long hexagon socket cap screws for FBJ 216 (3) and FBJ 217 (3)
2	K05 20 500	Dia. 4mm x 28mm long tension pin for FBJ 213
2	K05 25 166	M6 x 20mm long hexagon socket cap screws for FBJ 224
1	FBJ 205	Traverse nut
1	FBJ 213	Traverse screw
1	RJ 225	Spring

VERTICAL PROFILE JOINTER

No. Off	Part No.	Description
1	FBJ 140	Control arm
1	FBJ 13	Stone Turret
1	FBJ 17	Jointer Slide
1	FBJ 19	Turret Slide
1	FBJ 20	Vertical Slide
1	FDJ 51	Bearing Bracket
1	FBJ 88	Stud for turret
1	FBJ 55	Jointer Gib
1	FBJ 62	Turret Release Nut
1	FBJ 63	Turret Plunger
4	FBJ 67	Clamp Plate
8	FBJ 85	Stone Clamp Pin
1	FBJ 120	Locking Nut for Horizontal Adjustment
1	FBJ 124	Locking Pad Slide
1	FBJ 131	Vertical Adjusting Screw
1	FBJ 132	Slide Strip
1	FBJ 133	Locking Strip
1	FDJ 127	Nut for Vertical Adjustment
1	FBJ 135	Stop Screw for Horizontal Adjustment
1	FBJ 136	Pivot Pin for Control Arm
1	FBJ 137	Pivot Block for Control Arm
1	FBJ 139	Locking Plate
1	FDJ 118	Plunger Knob
1	FD 7749	Locking Washer
1	FBJ 138	Square end for vertical adjustment
1	FBJ 152	Thumb nut
1	K30 73 352	Jointer stone 3.1/2in. x 3in. x 3/4in.
1	K30 73 353	Jointer stone 2.1/2in. x 3in. x 3/4in.
1	K30 73 354	Jointer stone 2in. x 3in. x 3/4in.
1	K30 73 355	Jointer stone 1.1/2in. x 3in. x 3/4in.
1	K30 73 356	Jointer stone 1in. x 3in. x 3/4in.
1	K05 24 106	Spring No. 6
1	K30 09 304	10in. long x 3/8in. Oval Link chain
2	K05 04 101	3/16in. whit. x 3/8in. long round head screw
2	K05 11 101	3/16in. diameter washer
1	K05 22 233	Composite bush SN 030 x 5/8in. long for FBJ 140
8	K30 73 148	Inbrako set screws 1/4in. whit x 5/8in. long for FBJ 13
1	K05 08 474	Stud 1/2in. whit. x 2.1/4in. long for FBJ 17

VERTICAL PROFILE JOINTER

No. Off	Part No.	Description
1	FBJ 140	Control Arm
1	FBJ 13	Stone Turret
1	FBJ 17	Jointer Slide
1	FBJ 19	Turret Slide
1	FBJ 20	Vertical Slide
1	FDJ 51	Bearing Bracket
1	FBJ 88	Stud for Turret
1	FBJ 55	Jointer for Gib
1	FBJ 62	Turret Release Nut
1	FBJ 63	Turret Plunger
4	FBJ 67	Clamp Plate
8	FBJ 85	Stone Clamp Pin
1	FBJ 120	Locking nut for Horizontal Adjustment
1	FBJ 124	Locking Pad Slide
1	FBJ 131	Vertical Adjusting Screw
1	FBJ 132	Slide Strip
1	FBJ 133	Locking Strip
1	FDJ 127	Nut for Vertical Adjustment
1	FBJ 135	Stop Screw for Horizontal Adjustment
1	FBJ 136	Pivot Pin for Control Arm
1	FBJ 137	Pivot Block for Control Arm
1	FBJ 139	Locking Plate
1	FDJ 118	Plunger knob
1	FD 7749	Locking Washer
1	FBJ 138	Square end for Vertical Adjustment
1	FBJ 152	Thumb Nut
1	K30 73 352	Jointer Stone 3.1/2in. x 3in. x 3/4in.
1	K30 73 353	Jointer Stone 2.1/2in. x 3in. x 3/4in.
1	K30 73 354	Jointer Stone 2in. x 3in. x 3/4in.
1	K30 73 355	Jointer Stone 1.1/2in. x 3in. x 3/4in.
1	K30 73 356	Jointer Stone 1in. x 3in. x 3/4in.
1	K05 24 106	Spring No. 6
1	K30 09 304	10in. long x 3/8in. Oval Link Chain
2	K05 04 101	3/16in. whit. x 3/8in. long round head screw
2	K05 11 101	3/16in. washer

VERTICAL PROFILE JOINTER

No. Off	Part No.	Description
1	K05 22 233	Composite Bush SN 030 x 5/8in. long for FBJ 140
8	K30 73 148	Inbrako set screws 1/4in. whit. x 5/8in. long for FBJ 13
1	K05 08 474	Stud 1/2in. whit. x 2.1/4in. long for FBJ 17
1	K05 10 107	Hexagon nut 1/2in. whit. for FBJ 17
2	K05 06 117	Hexagon hole grubscrews 1/4in. whit. x 5/8in. long for FBJ 19
2	K05 10 302	Hexagon locknuts 1/4in. whit. for FBJ 19
2	K05 01 101	Socket head capscrews 3/16in. whit. x 1/2in. long for FBJ 19
2	K05 06 104	Hexagon hole grubscrews 3/16in. whit. x 1/2in. long for FBJ 20
2	K05 10 301	Hexagon locknuts 3/16in. whit. for FBJ 20
2	K05 01 123	Socket head capscrews 1/4in. whit. x 1/2in. long for FDJ 51
2	K05 20 614	Dowel pin 1/4in. dia. x 1in. long for FDJ 51
1	K05 08 419	Stud 1/4in. whit. x 1.1/4in. long for FBJ 124
1	K05 11 102	Washer for FBJ 124 1/4in. bore
1	K05 10 103	Hexagon nut 1/4in. whit. for FBJ 124
2	K05 10 305	Hexagon locknuts 1/2in. whit. for FBJ 132
2	K05 01 101	Socket head capscrews 3/16in. whit. x 1/2in. long for FBJ 132
1	K05 08 419	Stud 1/4in. whit. x 1.1/4in. long for FBJ 133
1	K05 11 102	Washer 1/4in. bore for FBJ 133
1	K05 10 103	Nut 1/4in. whit. for FBJ 133
2	K05 01 128	Socket head capscrews 1/4in. whit. x 1.1/4in. long for FBJ 137
1	K05 20 636	Dowel pin 3/8in. dia. x 1in. long for FBJ 137
1	K05 07 105	Square head screw 1/4in. whit. x 1.1/4in. long for FBJ 139

VERTICAL STRAIGHT JOINTER

No. Off	Part No.	Description
1	FDJ 172	Front Plate for Saddle
1	FBJ 18	Vertical Jointer Slide
1	FDJ 42	Saddle for Vertical Slide
1	FDJ 51	Bearing bracket
1	FBJ 125	Vertical Adjustment Screw
1	FBJ 126	Plunger
1	FDJ 132	Knob for adjusting screw
1	FDJ 136	Stone holder
1	FDJ 162	Nut
1	FDJ 163	Wear Strip
1	FDJ 168	Clamp plate for stone
1	FDJ 169	Adjusting screw for stone
1	FDJ 170	Plate for adjusting screw
1	FD 7749	Locking washer
1	RJ 137	T locking handle
1	FDJ 173	Jointer stone
1	K30 09 304	10in. long x 3/8in. Oval link chain
2	K05 04 101	3/16in. whit. x 3/8in. long round head screw
2	K05 11 101	3/16in. diameter washer
4	K05 05 127	Hexagon head screws 1/4in. whit. x 3/4in. long for FDS 172
1	K05 08 474	Stud 1/2in. whit. x 2.1/4in. long for FBJ 18
1	K05 10 107	Hexagon nut 1/2in. whit. for FBJ 18
2	K05 01 123	Socket head capscrews 1/4in. whit. x 1/2in. long for FBJ 51
2	K05 20 614	Dowel pin 1/4in. dia. x 1in. long for FBJ 51
1	K05 06 103	Hexagon hole grubscrew 3/16in. whit. x 3/8in. long for FDJ 42
2	K05 06 118	Hexagon hole grubscrew 1/4in. whit. x 3/4in. long for FDJ 42
2	K05 10 302	Hexagon locknut 1/4in. whit. for FDJ 42
2	K05 06 115	Hexagon hole grubscrews 1/4in. whit. x 3/8in. long for FDJ 136
2	K05 01 123	Socket head capscrews 1/4in. whit. x 1/2in. long for FDJ 163
2	K05 01 101	Socket head capscrews 3/16in. whit. x 1/2in. long FDJ 70
2	K05 20 604	Dowel Pins 3/16in. dia. x 1.1/4in. long for FDJ 170

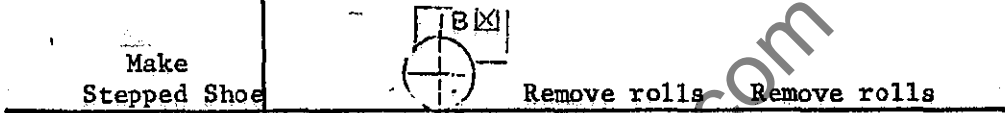
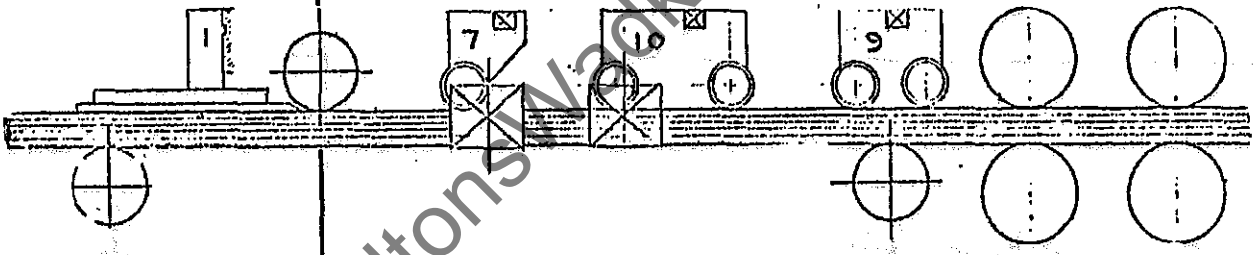
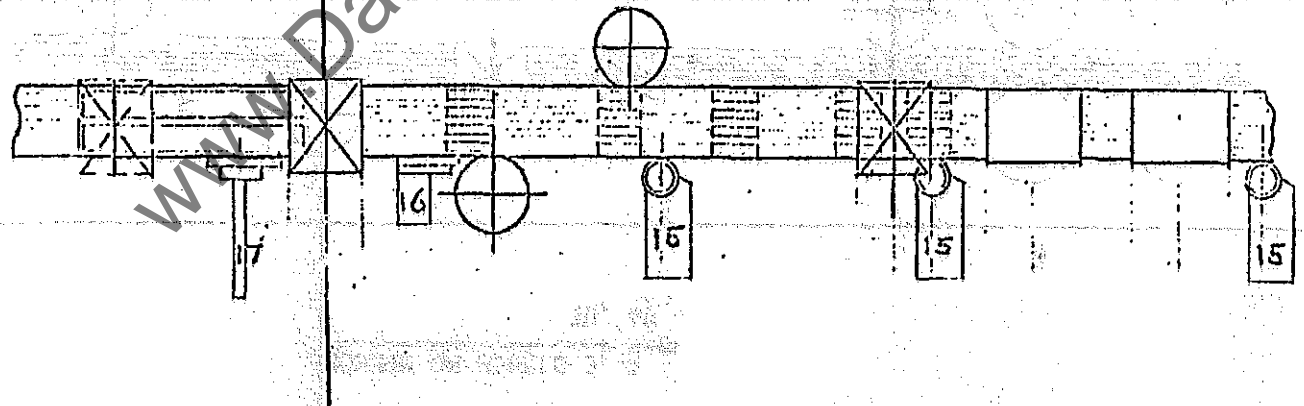
CAPACITY	STANDARD PRESSURES SUPPLIED WITH MACHINE		FBN 230
<p>MODELS 1, 2, 1U, 2U</p>		<p>COMMON ON MODELS 3, 4, 3U, 4U</p>  <p>Make Stepped Shoe</p> <p>Remove rolls</p> <p>Remove rolls</p>	
<p>MINIMUM WIDTH = 11mm (7/16in.)</p> <p>MINIMUM THICKNESS = 12mm (1/2in.)</p>			
<p>MINIMUM LENGTH = 600mm (24in.)</p>	 <p>MODEL 1U SEE ALSO P. 54</p> <p>MODEL 2U see also P. 56</p>		

CAPACITY

SHORT STOCK PRESSURES TO SPECIAL ORDER

FBN 230

MODELS 1, 2
1U, 2U

COMMON ON MODELS 3, 4
3U, 4U

MINIMUM
LENGTH
= 350mm (14in.)

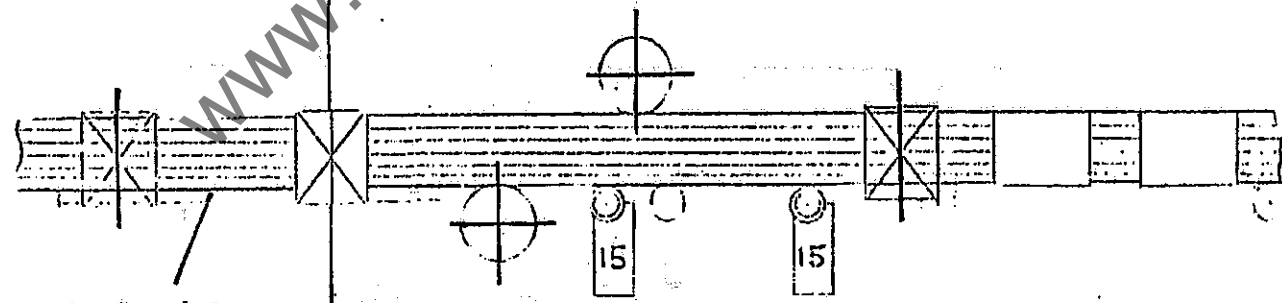
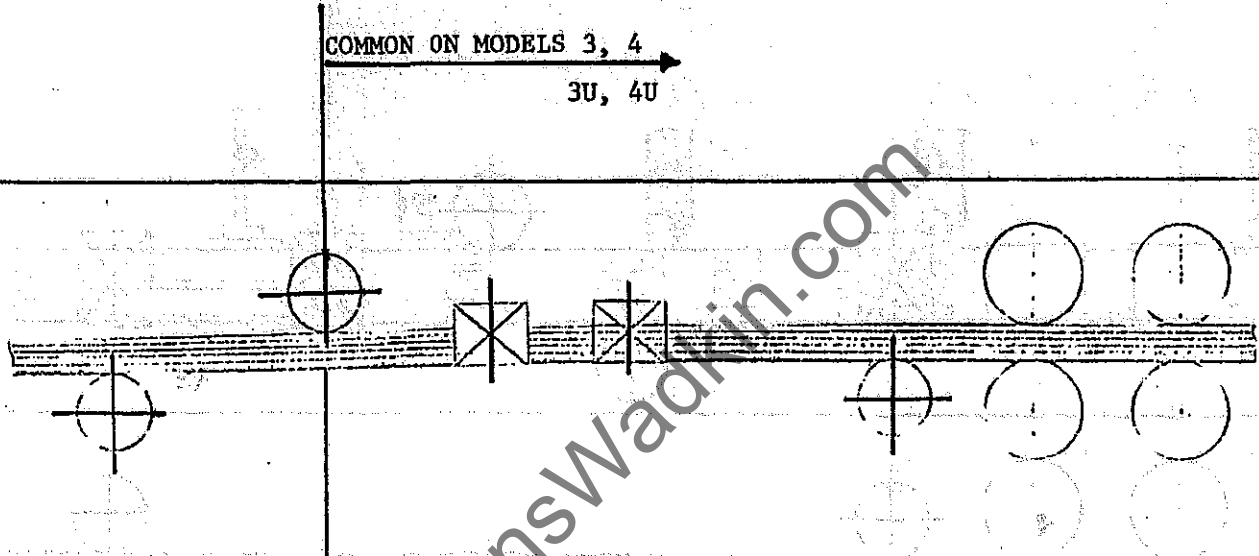

Make Special
long wooden
shoe

CAPACITY

NARROW STOCK PRESSURES TO SPECIAL ORDER

FEB 2

MODELS

1, 2,
1U, 2U

COMMON TO MODELS 3, 4,

3U, 4U

MINIMUM WIDTH

= 11mm (7/16in.)

NOTE: This shoe
does not reduce
the minimum width
but eliminates the
need to make special
Stepped Wooden Pads

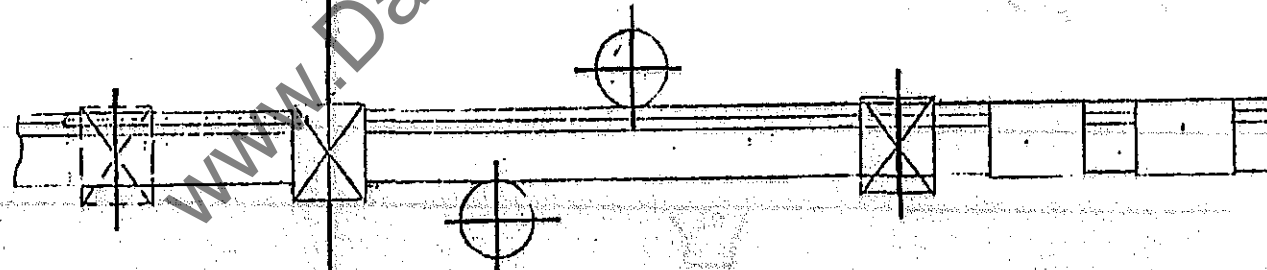
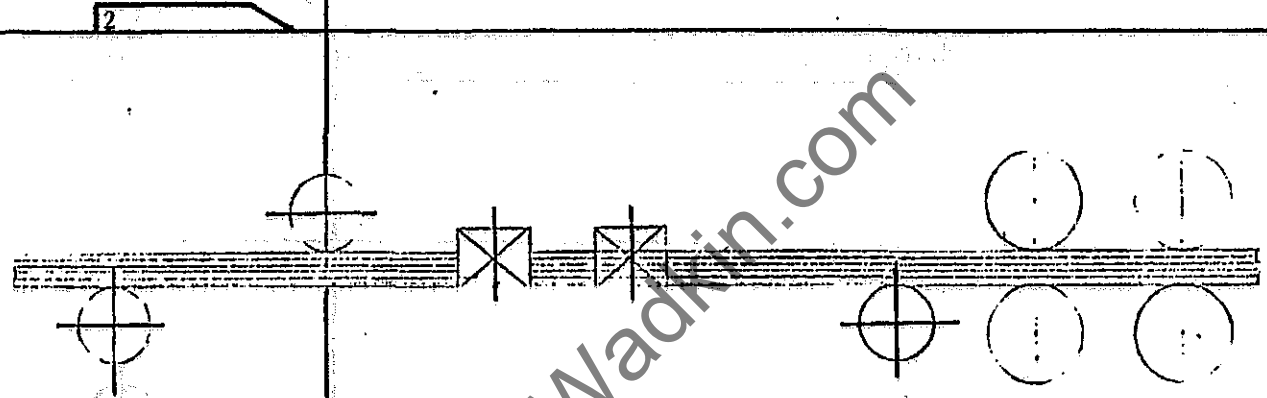

MODEL 1U see also page 55

MODEL 2U see also page 57

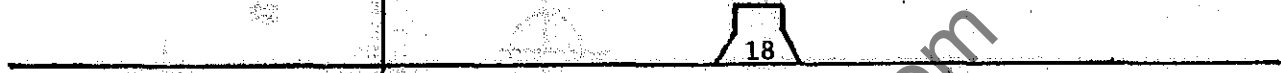
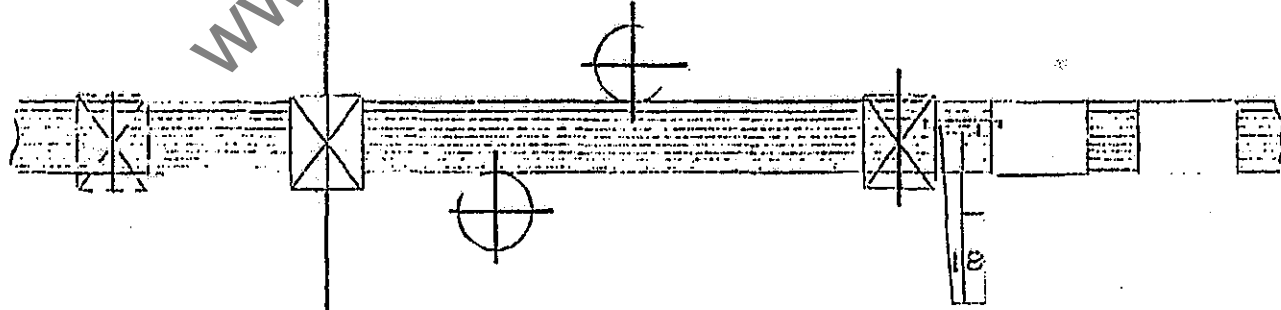
CAPACITY	THIN STOCK PRESSURES TO SPECIAL ORDER		FBN 230
<p>MODELS 1, 2 1U, 2U</p> <p>MINIMUM THICKNESS = 6mm (1/4in.)</p> <p>NOTE: Packing plates required (to special order) between feed roll for thin material</p>		<p>COMMON ON MODELS 3, 4 3U, 4U</p> 	
			

CAPACITY

OPTIONAL PRESSURES TO SPECIAL ORDER

FBN 230

MODELS

1, 2,
1U, 2U

NOTE: Pressure
(5) may be used
as a triple
unit as shown
or as a double
unit with pad
pressure (3)

TRIPLE ROLLER
PRESSURE ONLY

MINIMUM LENGTH
= 450mm (19in.)

DOUBLE ROLLER
PLUS PAD

CAPACITY NOT
RESTRICTED

COMMON ON MODELS 3, 4,

3U, 4U

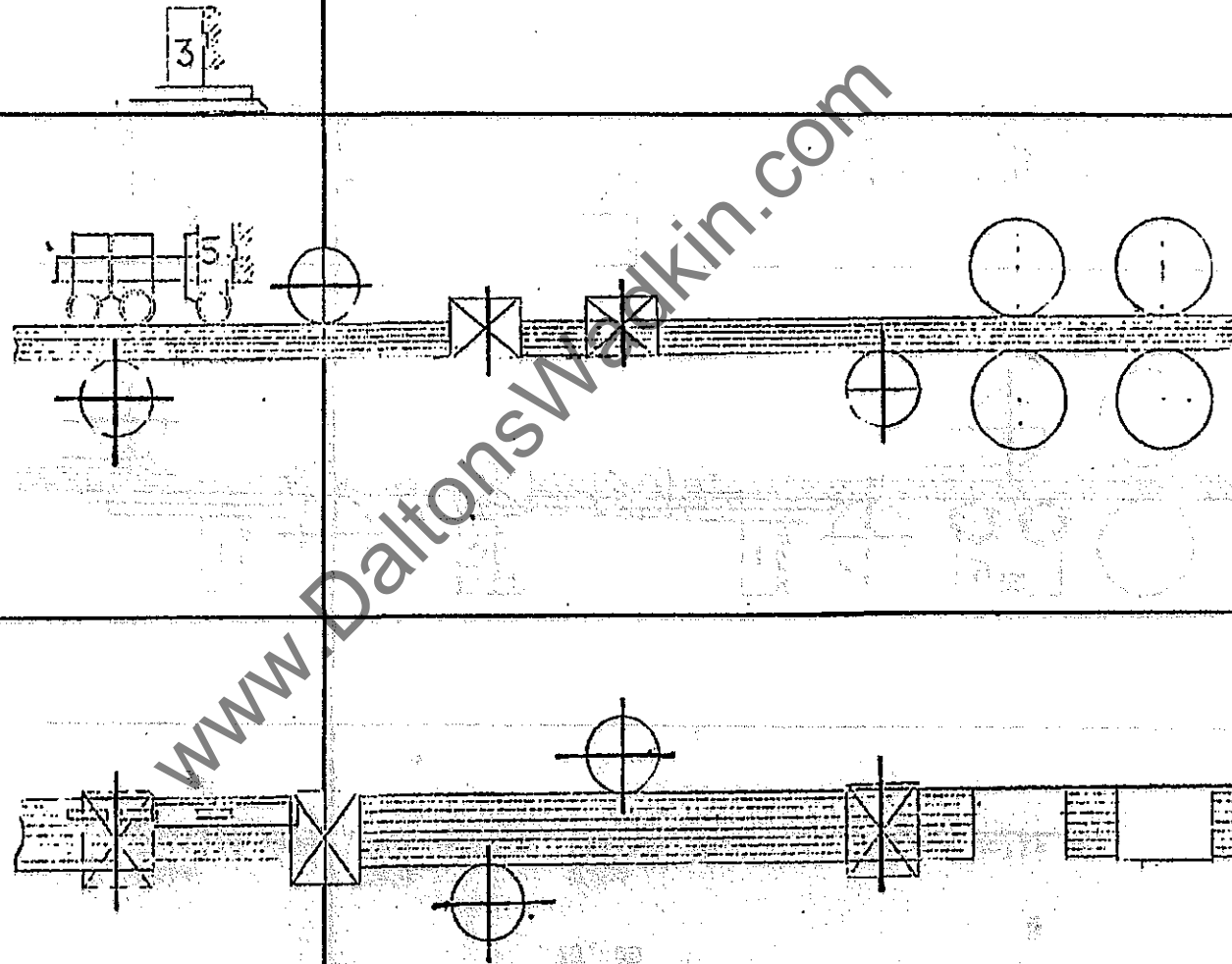

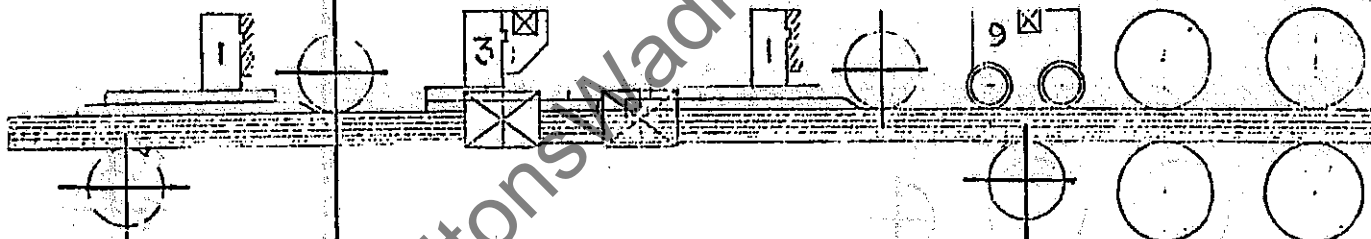
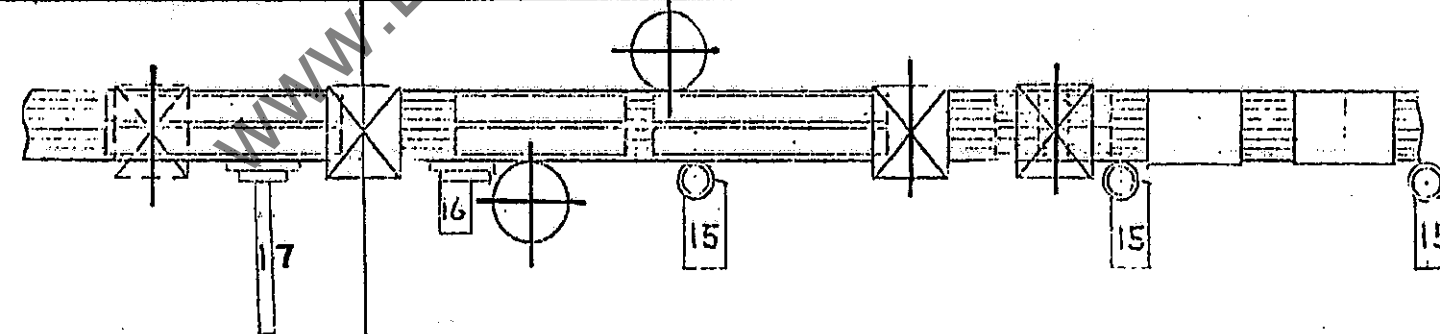
CAPACITY	STANDARD PRESSURES SUPPLIED WITH MACHINE		FBN 230
<p>MODELS 5, 6 5U, 6U</p> <p>MINIMUM WIDTH = 9mm (3/8in.)</p> <p>MINIMUM THICKNESS = 12mm (1/2in.)</p> <p>MINIMUM LENGTH = 600mm (24in.)</p>		<p>COMMON TO MODELS 7, 8 7U, 8U</p> <p>Make Stepped Shoe Make Stepped Shoe Make Stepped Shoe Remove rolls</p>	
			
	 <p>Model 5U see also page 54</p> <p>Model 6U see also P 56</p>		

CAPACITY

SHORT STOCK PRESSURES TO SPECIAL ORDER

FBN 230

MODELS

5, 6
5U, 6U

MINIMUM LENGTH
= 350mm (14in.)

COMMON ON MODELS 7, 8

7U, 8U

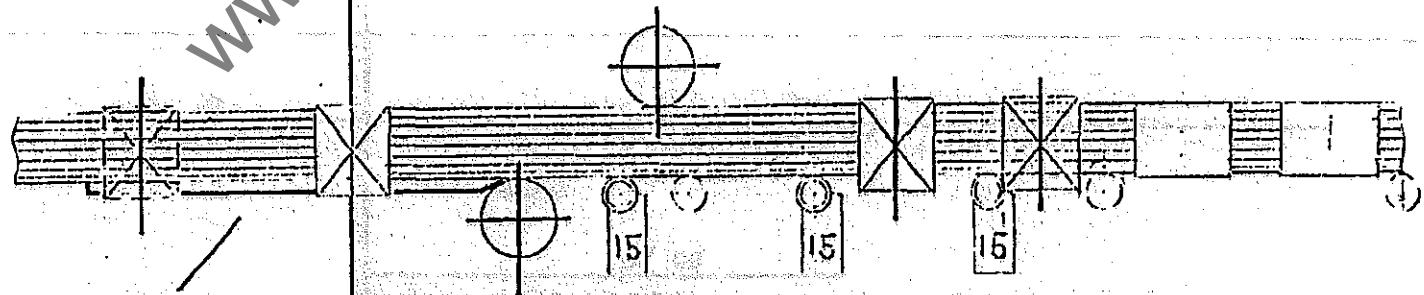
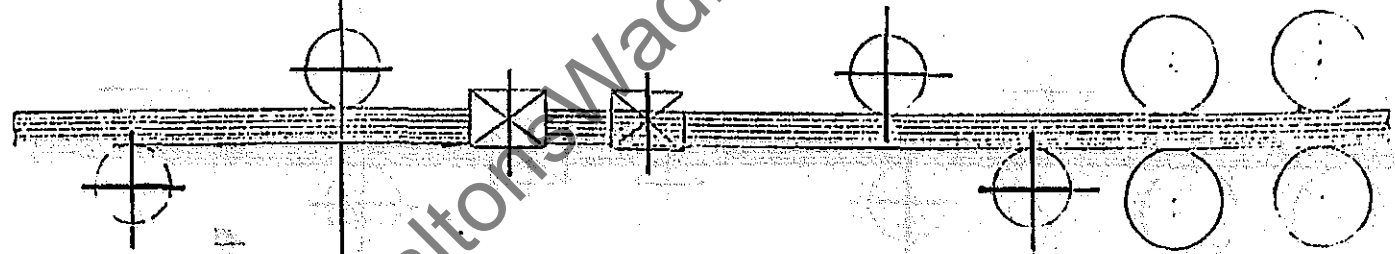

Make
Special Long
Wooden shoe

CAPACITY

NARROW STOCK PRESSURES TO SPECIAL ORDER

FBN 230

Models:
5, 6
5U, 6U

MINIMUM WIDTH
= 9mm (3/8in.)

NOTE: These units
do not reduce
the minimum
width but do
eliminate the
need to make
special stepped
wooden pads

COMMON ON MODELS 7, 8

7U, 8U

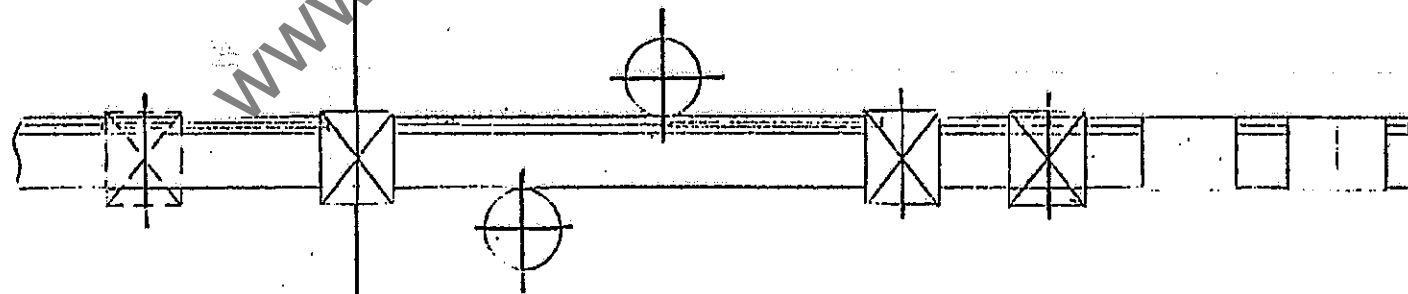
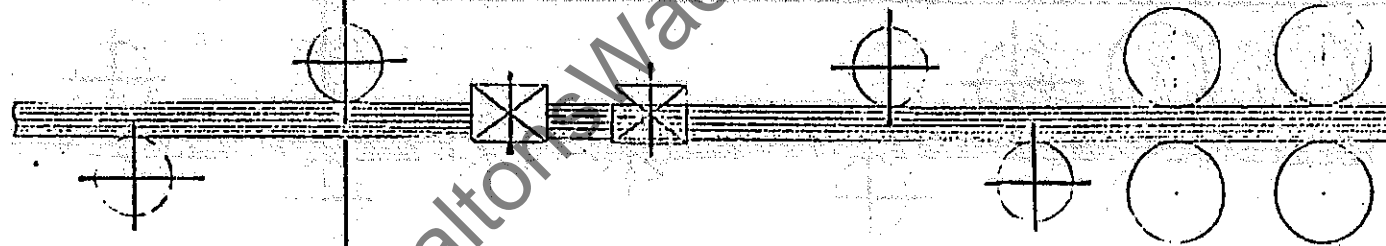
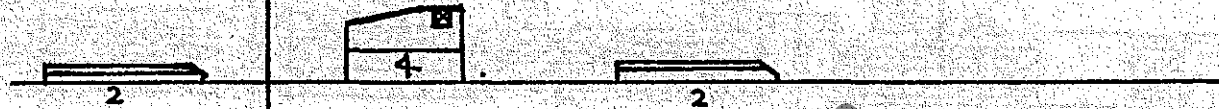

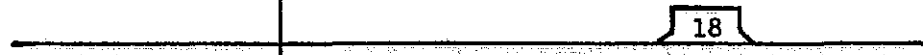
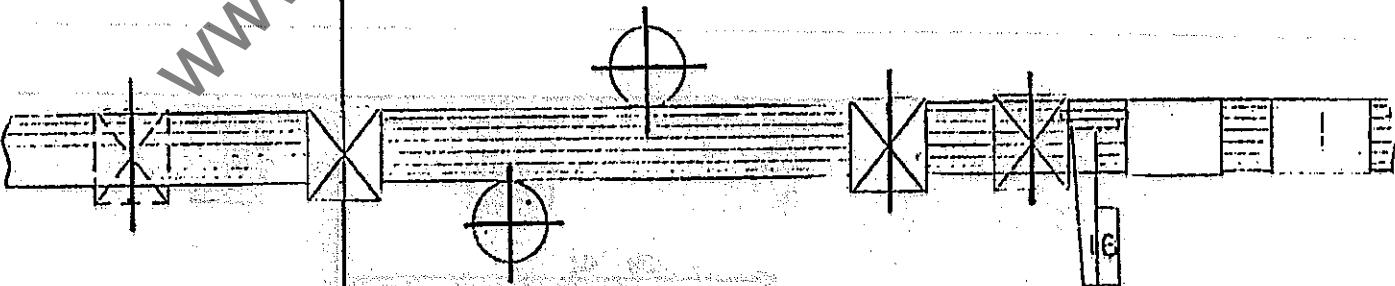

MODEL 5U see also Page 55

MODEL 6U see also Page 57

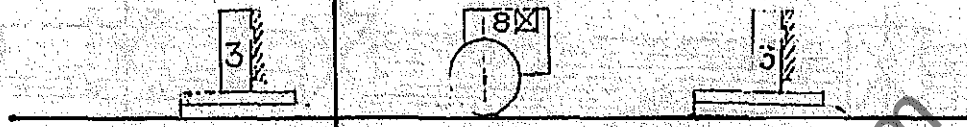
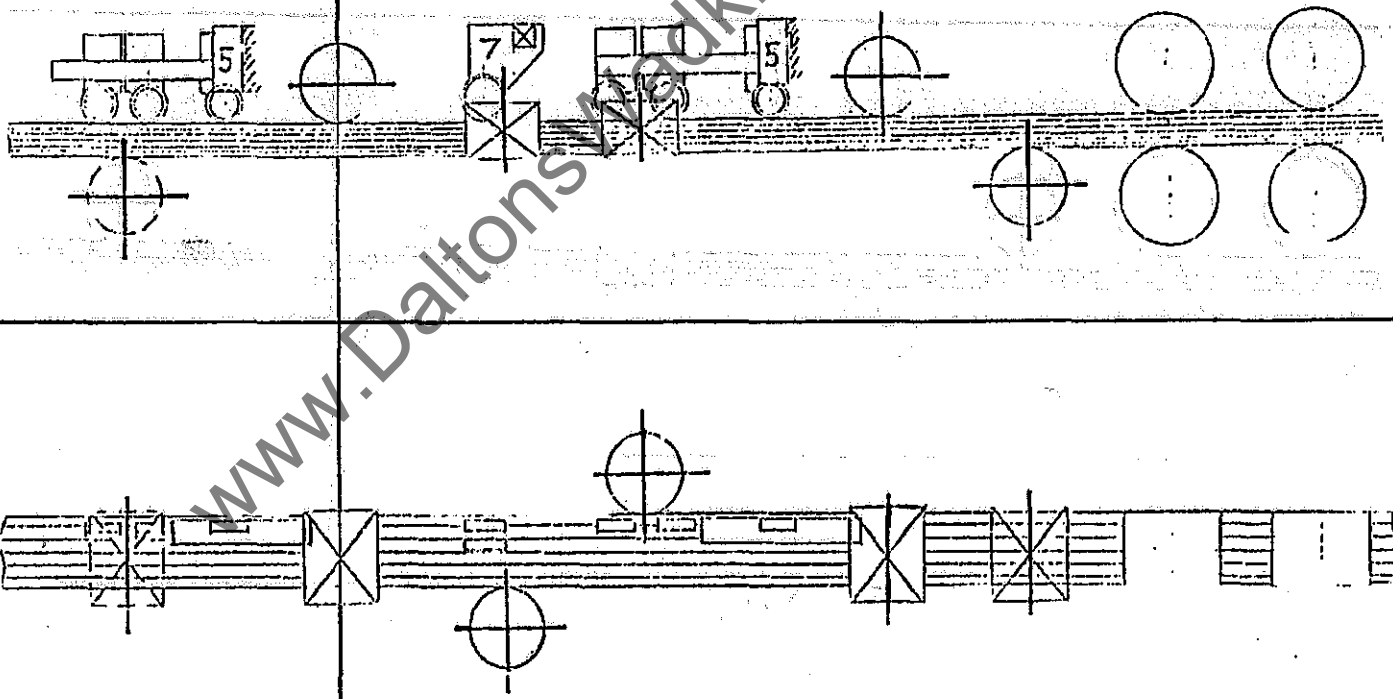
CAPACITY	THIN STOCK PRESSURES TO SPECIAL ORDER		FBN 230
<p>MODELS: 5, 6 5U, 6U</p> <p>MINIMUM THICKNESS = 6mm (1/4in.)</p> <p>NOTE: Packing plates required also between feed rolls for thin material (to special order)</p>		<p>COMMON ON MODELS 7, 8 7U, 8U</p> 	
			

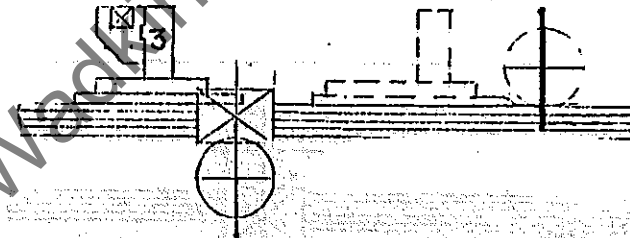
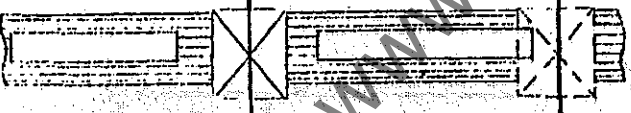
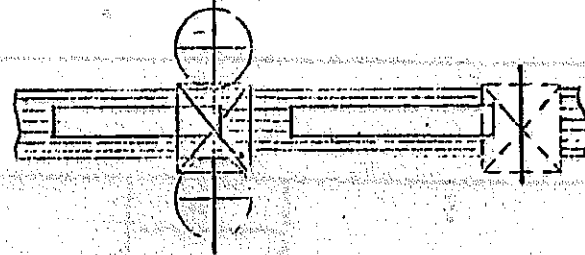
CAPACITY	OPTIONAL PRESSURES TO SPECIAL ORDER	
<p>MODELS 5, 6, 5U, 6U</p> <p>NOTE: Pressure (5) may be used as a triple unit as shown (which limits the minimum length to 450mm - 18in.) or as a Double unit with pad pressures (3) which does not restrict minimum length.</p> <p>NOTE: Pressure (7) restricts the minimum width to 50mm (2in.) pressure (8) is fitted in place of (7) for narrow stock: minimum width = 11mm (7/16in.).</p> <p>NOTE: If these roller pressures are to be used for wide material two units should be mounted side by side at each position</p>	<p>COMMON ON MODELS 7, 8 7U, 8U</p> 	

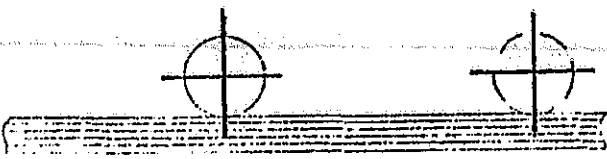
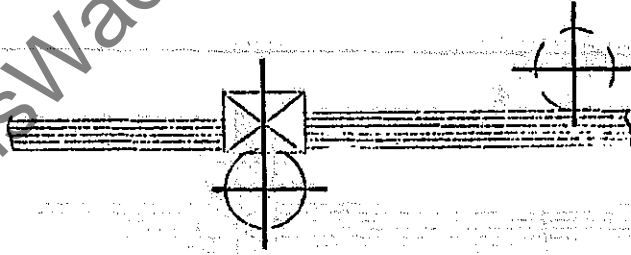
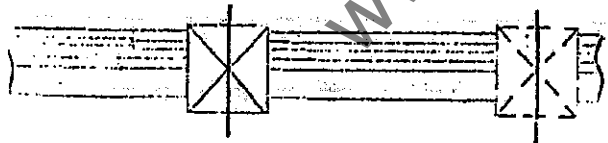
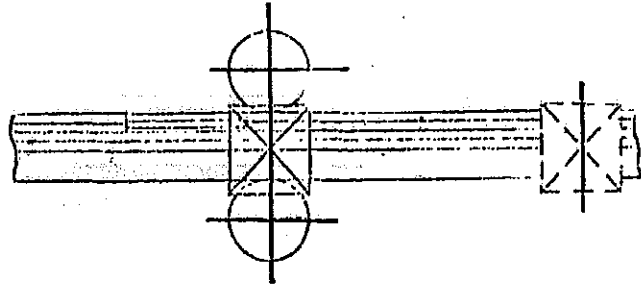

CAPACITY	STANDARD PRESSURES SUPPLIED WITH MACHINE	UNIVERSAL HEAD
<p>MODELS: 1U, 3U, 5U, 7U 5FPU, 7FPU</p>	<p>Make <u>Stepped Shoe</u></p>	<p>Make <u>Stepped Shoe</u></p>
<p>NOTE: THESE PRESSURES DO NOT RESTRICT THE CAPACITY AS STATED ON PREVIOUS PAGES</p> <p>NOTE: SIDE CONTROL IS BY UNIVERSAL HEAD FENCES</p> <p>NOTE: EXTRA PRESSURES ARE NOT REQUIRED FOR SHORT OR THIN MATERIAL</p>		
		
	<p>HEAD IN TOP POSITION</p>	<p>HEAD IN BOTTOM OR SIDE POSITIONS</p>

CAPACITY	NARROW STOCK PRESSURES TO SPECIAL ORDER	UNIVERSAL HEAD
<p>1U, 3U, 5U, 7U 5 FPU, 7FPU</p> <p>NOTE: This pressure does not reduce the minimum width but eliminates the need to make special stepped wooden pads</p>		
		
		
<p>HEAD IN TOP POSITION</p>	<p>HEAD IN BOTTOM OR SIDE POSITIONS</p>	

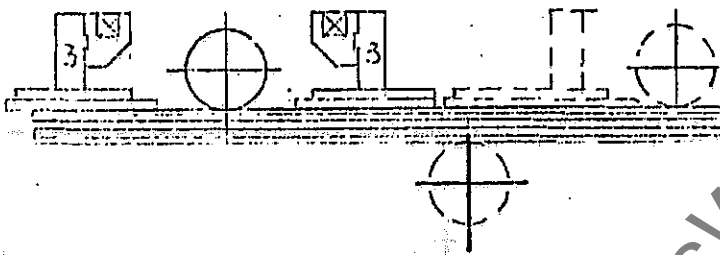
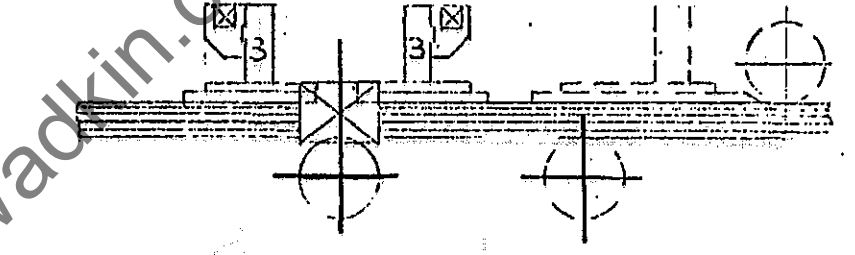
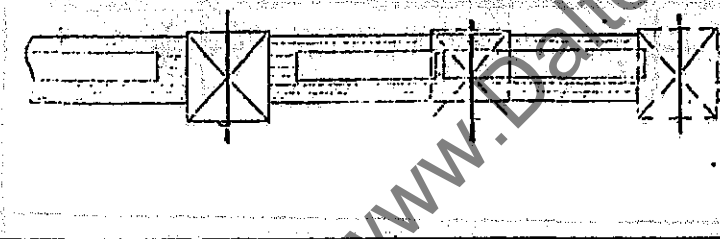
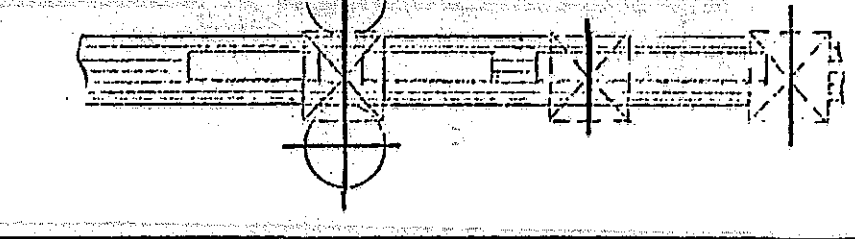
Jan 178

CAPACITY	STANDARD PRESSURES SUPPLIED WITH MACHINE	UNIVERSAL HEAD
<p>MODELS 2U, 4U, 6U, 8U, 6FPU, 8FPU</p>	<p>Make _____ <u>Stepped Shoe</u> Make _____ <u>Stepped Shoe</u></p>	<p>Make _____ <u>Stepped Shoe</u> Make _____ <u>Stepped Shoe</u></p>
<p>NOTE: These pressures do not restrict capacity as stated on previous pages</p> <p>NOTE: Side control is by Universal Head Fences</p>		
<p>NOTE: Extra pressures are not required for short or thin material</p>	 <p style="text-align: center;">HEAD IN TOP POSITION</p>	 <p style="text-align: center;">HEAD IN BOTTOM OR SIDE POSITION</p>

Page 57

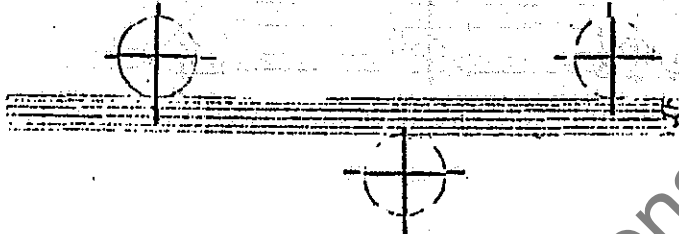
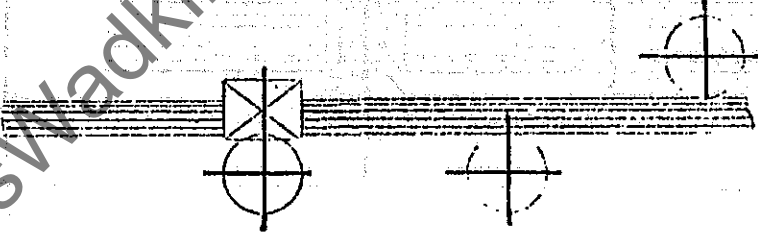
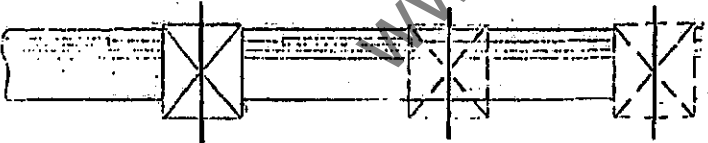
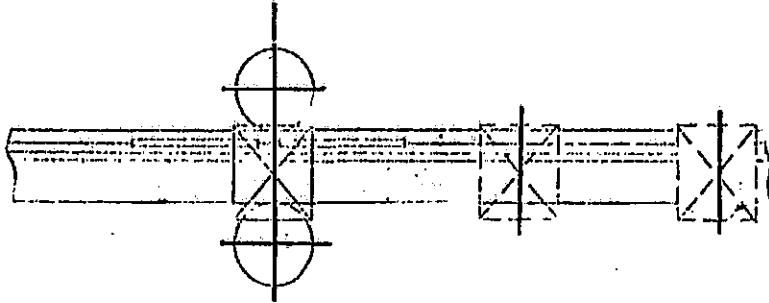
CAPACITY	NARROW STOCK PRESSURES TO SPECIAL ORDER	UNIVERSAL HEAD
<p>MODELS: 2U, 4U, 6U, 8U 6FPU, 8FPU</p> <p>NOTE: These pressures do not reduce the minimum width but eliminate the need to make special stepped wooden pads</p>		
		
		
	<p>HEAD IN TOP POSITION</p>	<p>HEAD IN BOTTOM OR SIDE POSITIONS</p>

LUBRICATION AND MAINTENANCE

In designing the "WADKIN" "FBN" Moulders much attention has been given to the question of maintenance and every endeavour has been made to keep lubrication maintenance to a minimum. In consequence of this 'sealed' for life' bearings and 'oilite' bushes have been widely used.

However, there are exceptions which are as follows:-

In electric motors where 'sealed for life' bearings have not been fitted these are provided with grease nipples.

DAILY

Oil machine slideways and raised and lower screws with "WADKIN" Grade L.4.oil.

CUTTERBLOCK SPINDLES - have been fitted with permanently lubricated bearings and should give trouble free service.

The pneumatic lubricating unit is conveniently located on the main frame of the machine under the infeed table. It comprises of a filter, regulator, "SOLENOID" and oil dispenser.

The latter should be filled with "MOBIL" ALMO NO: 1.oil.

The oil dispenser should be adjusted to give one drip of oil every minute and the air pressure should be regulated to give a pressure of 5.63 kg/cm² (80lbs./sq.inch).

NOTE: Where a Universal head is fitted the following lubrication points should be covered. Those at either end of the spindle assembly and also at either end of the motor. The slideways should be lubricated with Grade L.4 oil weekly. The vertical slide leadscrew should be oiled via the 'oiler' on the end of the drive adjusting square.

IMPORTANT

If water condensation collects in the air line, it is recommended that an electrical extractor and water trap complete with 'turn off' gauge be incorporated in the circuit immediately before the filters.

It is strongly recommended that the valves be opened daily to ensure that water does not enter the air line.

EVERY THREE MONTHS

Lubricate all electric motors with "WADKIN" Grade L.6 grease at the nipples provided.

LUBRICATION AND MAINTENANCE....CONTD.

EVERY SIX MONTHS

Each Universal Joint driving the feed rolls have three lubricating nipples, two of these provide the means for lubricating the "Needle Roller Bearings" and the other for the "Spline Assembly".

When re-lubricating the drive shafts, use only greases saponified with Lithium from consistency Class 2. with 265/295 penetration and a dropping point of approximately 180°C.

THE FOLLOWING GREASES COMPLY:-

ARAL	BP	CALYPSOL	ESSO	MOBIL	SHELL	SUNOCO	VALVOLINE
Aral LF 2	Energrease LS 2	Calypsol H 442	Esso Beacon 2	Mobilgrease MP	Shell Retinax A	Multi Duty 2	Valvoline LB 2

IMPORTANT

Do not exert high pressure during lubrication otherwise the seals may be damaged

Check the quantity of lubricant in the gearbox of the feedworks. Before leaving our Works the gearbox is packed with 5.1 Kilos. (11.3lbs) of "SHELL" Blameta Grease Grade 00.

Check the quantity of oil in the oil bath of gearbox of the feed rolls. The oil bath holds three litres (approximately six pints) of "WADKIN" Grade L.4.oil.

APPROVED LUBRICANTS

WADKIN	CASTROL	B.P.	SHELL	MOBIL	ESSO	GULF	CALTEX
L.1.	HYPIN AWS 32	ENERGOL H.P.32	VITROL 32	DTE OIL LIGHT 24	NUTO 44 OR ESSTIC H44	HARMONY 43 AW	RANDO OIL HDA
L.2.	ALPHA ZN 150	ENERGOL H.P.150 OR CS 150	VITREA 150	VACTRA EXTRA HEAVY	ESSTIC 65	SERVICE 13	URSA P40
L.4.	MAGNA .68	ENERGOL H.P.68 OR CS 68	VITREA 68	VACTRA OIL HEAVY MEDIUM	ESSTIC 50	SERVICE 51	URSA P20
L.6:	SPHEEROL AP 3	ENERGREASE LS 3	ALVANIA GREASE NO.3	MOBILPLEX GREASE NO.48	BEACON 3	GULFCROWN GREASE NO.3	REGAL STARTAK PREMIUM 3

L.1. OIL Hydraulic oil with anti-corrosion, anti-oxidation, anti-wear, anti-foam performance.

L.2. Oil Gear oil (viscosity 150 centi-stokes at 40°C.)

L.4. Oil Plain mineral oil (viscosity 68 centi-stokes, at 40°C.)

L.6. GREASE NLGI NO.3 consistency Lithium bearing grease.

- 1) "ATLAS" "COPCO" CYLINDER
- 2) QUICK EXHAUST VALVE KQE 1/B4
- 3) 5. PORT VALVE KMV9/95
- 4) 3. PORT VALVE - PUSH BUTTON KMV1/43
- 5) 3. PORT VALVE - "SOLENOID" OPERATION KMVS2/20/4P
- 6) PRESSURE REGULATOR KASP. 100PB4
- 7) PRESSURE GAUGE 0 - 100 304 - M1E0
- 8) LUBRICAT OR CONTROL ASSEMBLY K30 61 717

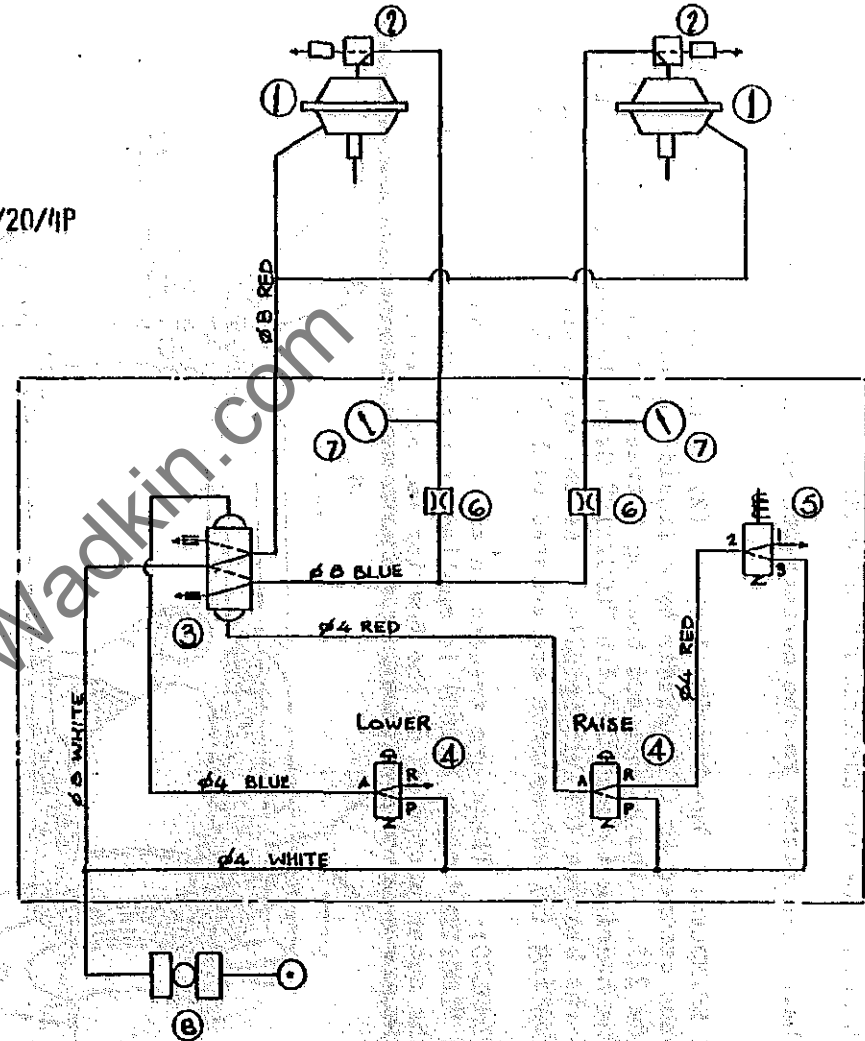

DIAGRAM FOR PNEUMATIC FEEDROLL CONTROL

20,3,81	F
	E
	D
	C
	B
<p>VERAL TOLERANCES, LIMITS FACE FINISH, UNLESS STATED</p> <p> 0.04 IN ANY LENGTH UP TO 300. PLUS 0.04/300 THEREAFTER 0.08mm T.R. MAX. 0.02mm MAX. ±0.25° MAX. </p> <p> DIMENSIONS ±0.1mm } NUM ±0.1mm } ACCUMULATIVE </p> <p> 6.3-25.0 MICRONS, POLISH M/C 14-2.2 MICRONS, FINISH M/C 1.4-3.2 MICRONS, POLISH GRD 0.4-0.8 MICRONS, FINISH GRD </p> <p> DIMENSIONS IN MILLIMETRES UNLESS STATED SPECIFICATION MUST PASS THE FIRST TEST A BATCH BEFORE STARTING IN. </p>	

ANGLE PROJECTION	DATE	A	WADKIN LTD. LEICESTER		QTY.	MATERIAL
R TO	DRAWN		DIAGRAM FOR PNEUMATIC FEEDROLL CONTROL		SCALE	PART No.
	CHECKED					

GENERAL MAINTENANCE.

CHANGING THE BEARINGS OF THE CUTTERBLOCK SPINDLES.

The bearings have been fitted to the cutterblock spindles (1) in an orthodox manner.

VERTICAL SIDE SPINDLES:- The bearing locknut (2) at the non-drive end of the spindle has been secured to the spindle by a liquid engineering adhesive "LOCTITE" Grade 221. The associated bearing between its outer periphery (3) and the bearing housing is secured with "LOCTITE" Grade LT.601, and also the inner bore of the bearing (4) and spindle. At the drive end only the inner bore of the bearing (5) and spindle are secured with "LOCTITE" Grade LT.601.

HORIZONTAL SPINDLES:- These are treated in exactly the same way except at the drive end "LOCTITE" Grade LT.601 is applied at both the inner bore (5) and between the outer periphery of the bearing (6) and bearing housing.

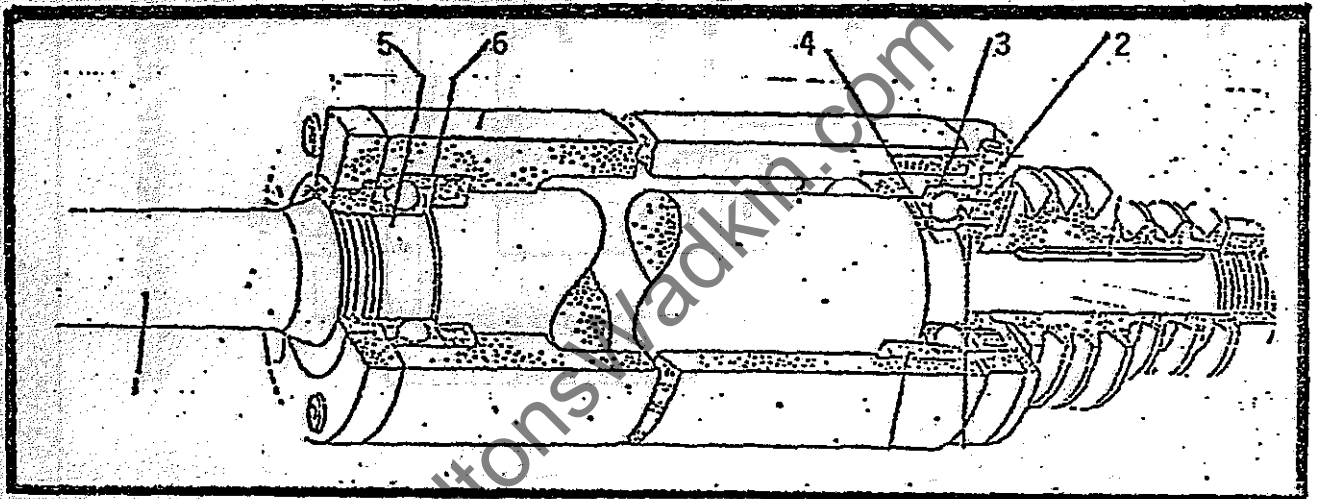

CUTTER BLOCK SPINDLE ASSEMBLY

PREPARATION PRIOR TO FITTING THE BEARINGS

Before fitting the new bearing the protective lubricant must be meticulously removed with petroleum spirit, triethanolamine OR other volatile solution.

In order to prevent the moving parts from being damaged by over cleansing add a small amount of the new lubricant to the cleansing agent at the second bath. The film of grease which remains after the solvent has evaporated will provide a good protection for the bearing.

At this stage the new bearings should be charged with "KLUBER" LUBRICANT TYPE ISOFLEX NBU 15. It is very important that the correct amount of grease be applied to the bearing preferably the amount should be measured by applying the formula.

G (weight in grams) = $d \times B \times 0.01$ where d = bore of the bearing in mm. and B = the width in mm. or approximately sufficient to fill one third of the bearing volume.

To disassemble the parts joined by "LOCTITE", not special tools are necessary, use normal tools and methods. If, however, the folding force of the "LOCTITE" joint is too great then apply a gentle heat and break the bond whilst the parts still hot. Sometimes the bond is left as a powder. This powder must be removed before applying further adhesive.

LUBRICATION AND MAINTENANCE

NOTE: In the cases where angular contact bearings have been employed. The cutterblock spindle bearings have been charged with Kluber Lubricant Type Isoflex NBU15 this is a permanent lubricant. It will only be necessary to re-charge in the event of the renewal of the bearings.

CHANGING THE BEARINGS

The bearings have been fitted to the cutterblock spindles (1) in an orthodox manner, however, at the drive end of the spindles a liquid engineering adhesive 'Loctite' Grade 601 has been applied to the external diameter of the bearing locknut (2)

PREPARATION PRIOR TO FITTING THE BEARINGS

Before fitting the new bearing the protective lubricant must be meticulously removed with petroleum spirit, triethanolamine or other volatile solution.

- In order to prevent the moving parts from being damaged by over cleansing add a small amount of the new lubricant to the cleansing agent at the second bath. The film of grease which remains after the solvent has evaporated will provide a good protection for the bearing.

At this stage the new bearings should be charged with KLUBER LUBRICANT TYPE ISOLFLEX NBU15. It is very important that the correct amount of grease be applied to the bearing preferably the amount should be measured by applying the formula.

G (weight in grams) = $d \times B \times 0.01$ where d = bore of the bearing in mm and B = the width in mm or approximately sufficient to fill one third of the bearing volume.

To disassemble the parts jointed by 'Loctite', no special tools are necessary to disassemble the parts jointed by 'Loctite', use normal tools and methods. If, however, the holding force of the 'Loctite' joint is too great then apply a gentle heat and break the bond whilst the parts are still hot. Sometimes the bond is left as a powder. This powder must be removed before applying further adhesive.

CUTTERBLOCK SPINDLE ASSEMBLY WITH GREASE LUBRICATED BEARINGS

ØIMPORTANT - Use 'Loctite' grade LT 601 on diameter marked *

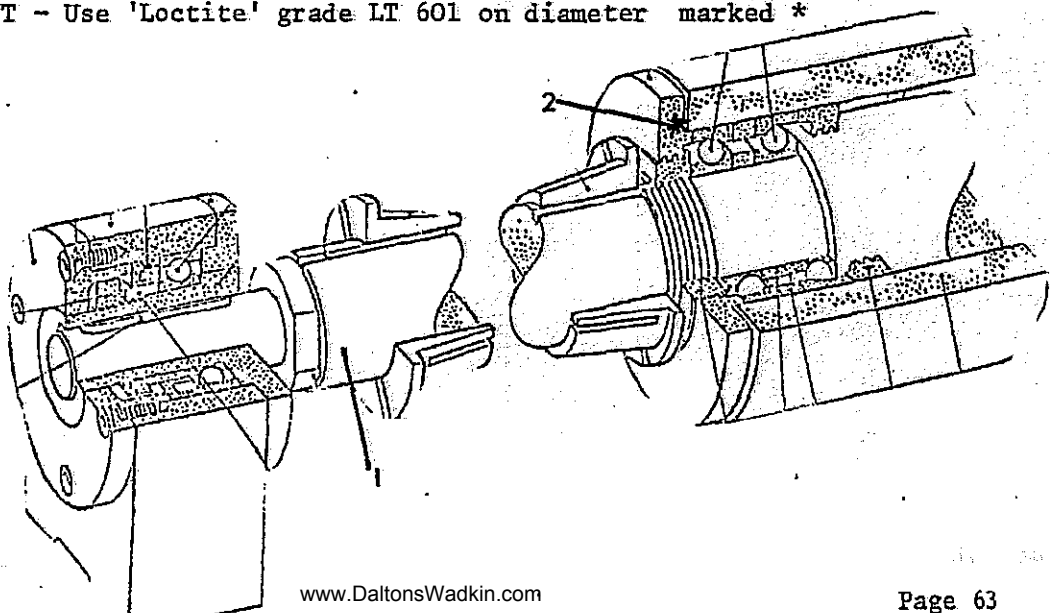

GENERAL MAINTENANCE

FITTING THE BEARINGS

It is not advisable to soak the bearing in a degreasing agent as this removes the protective lubricant from the bearing elements. The outer and inner bearing diameters should be cleaned using a clean cloth dampened with a degreasing agent and allowed to dry. Also ensure that the mating parts are clean and free from grease, then apply a thin bead of 'Loctite 601' to the bearing surface only and position it in the spindle barrel or housing and at the same time rotating the bearing slowly so that the 'Loctite' spreads evenly over the bearing surface.

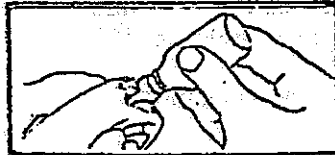

The bearings should then be locked in position by the locknuts or securing rings.

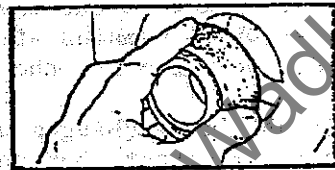

Allow the 'Loctite' adhesive to cure for three hours with a minimum of one hour before use, however, the assembly can be handled after fifteen minutes.

Having fitted the bearings, they should be run in for a period of approximately 16 hours during which time they should not be fully loaded particularly so if the ambient temperatures are high or low.

Bearings that are fully loaded without a previous 'run in' period will suffer damage and have a short life. Bearings always experience an increase in temperature whilst they are being run in even if no particular thermal stress is put on them, the temperature will become normal once they are run in.

IF YOU FB OR FEN HAS GREASED FOR LIFE SPINDLE BEARINGS OR YOU ARE CONVERTING TO GREASED FOR LIFE BEARINGS

READ THIS DRAWING CAREFULLY

BEFORE COMMENCING ANY MAINTENANCE

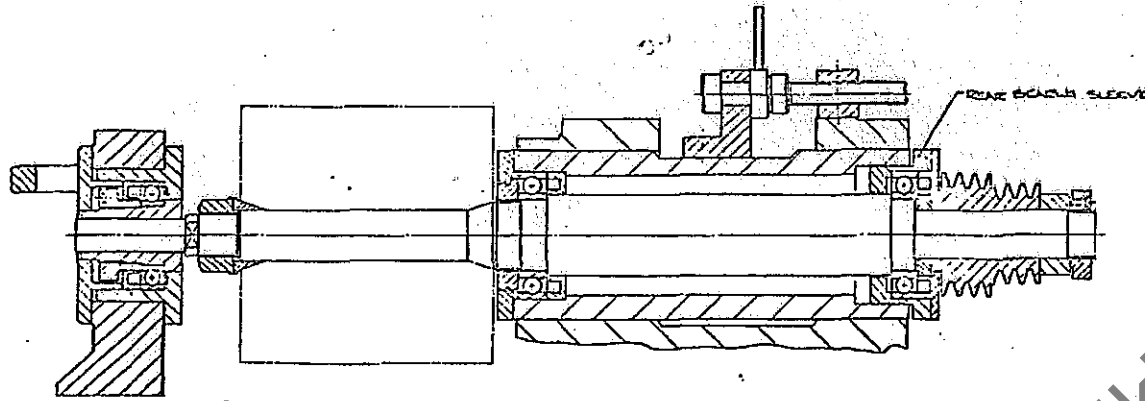

TYPICAL HORIZONTAL SPINDLE

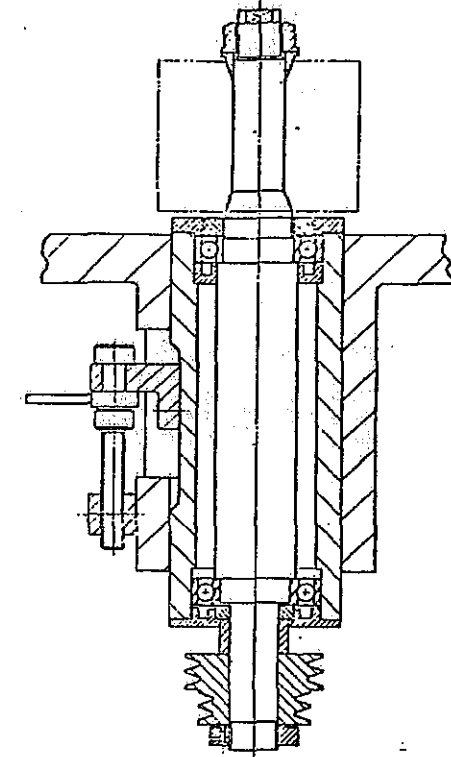

TYPICAL VERTICAL SPINDLE

POSITION	BEARING PART NUMBERS	
	SKED BEG	PRELUBED LIFE BEG
HORIZONTAL SPINDLES		
FRONT	K06 01 309	K06 20 110
REAR	K06 01 309	K06 20 110
VERTICAL SPINDLES		
TOP	K06 01 309	K06 20 110
BOTTOM	K06 01 309	K06 20 110
STANDARD OUTBOARD	K06 01 302	K06 20 106
SHOULDER LOADING OUTBOARD		
LARGE BEG	K06 01 302	K06 20 106
SMALL BEG	K06 01 128	K06 20 150

DO'S

- ALWAYS WEAR THIN POLYETHYLENE GLOVES TO HANDLE BEARINGS
- ALWAYS HEAVILY SPRAY KUBER ALFMP Q PASTE NB30 ON SPINDLE & WASH BEARING HOUSING DO NOT RUB IN
- ALWAYS MAINTAIN BEARINGS CLINICAL CLEANLINESS AFTER REMOVING FROM PROTECTIVE COVERING
- ALWAYS RUN BEARINGS IN UNLOADED 'NO LOAD' CONDITIONS (SEE DON'T'S W)
- ALWAYS CHECK BEARING TEMPERATURES WHEN RUNNING IN (MAX 65°C)
- ALWAYS RUN BEARING IN FOR AT LEAST TWO HOURS TOTAL AT LOW SPEED (SEE DON'T'S W)
- * CONSULT 'WADKIN' PROCEDURE FOR APPLYING KUBER GREASE BEARINGS BEFORE RE-GREASING
- ALWAYS USE YOUR COMMON SENSE TO ENSURE ABSOLUTE CLEANLINESS
- ALWAYS SMEAR OUTER BEARING HOUSING WITH LOCTITE LT 601

DON'TS

- NEVER ADD ANY MORE GREASE TO BEARING IT IS SUPPLIED WITH THE CORRECT AMOUNT APPLIED
- NEVER HANDLE BEARINGS WITH BARE HANDS HOWEVER CLEAN THEY ARE
- NEVER HANDLE BEARINGS WITH FLUFFY MATERIAL
- NEVER CLEAN & RE-GREASE BEARINGS WITHOUT CONSULTING 'PROCEDURE' NOTES (SEE DO'S W)
- NEVER BLOW BEARING OUT WITH AIR LINE, PROPRIETARY AEROSOL OR MOUTH
- NEVER EXPOSE BEARING TO CONTAMINATING CONDITIONS E.G. WORKBENCH, MACHINE ETC.
- * NEVER RUN BEARINGS IN UTILITALLY FOR LONGER THAN 10 MINS. ALLOW TO COOL BEFORE RE-STARTING

ADDITIONAL POINTS WHEN CONVERTING TO GREASED FOR LIFE BEARINGS

- BLANK ALL OIL WAYS WITH 1/8" B.S.P. BLANKING PLUGS
- REPLACE OLD REAR BEARING SLEEVE FB174B WITH NEW FB334B ON HORIZONTAL SPINDLES
- THOROUGHLY CLEAN SPINDLE HOUSING WITH PROPRIETARY DEGREASING AGENT AND DRY

GREASED FOR LIFE BEARINGS BECAME STANDARD ON FEN180 M/C N° 2054 5" FEN & 7" FEN M/C N° 511
 FEN 230 M/C N° 5030 9" FEN M/C N° 314B
 FEN 120 M/C N° 101B

SURFACE FINISH
 V - 200µm A/C
 VV - FINISH M/C
 VVV - ROUGH GRIND
 VVVV - FINISH GRIND

SUPPLEMENTAL LIMITS
 FRACTIONS 1/101"
 DECIMALS 1/100"
METRIC LIMITS
 SPINDLE NUMBERS - 2.5mm
 DECIMALS - 2.5mm

DATE: 24.10.75
 DESIGNED BY: G
 CHECKED BY: F
 DRAWN BY: E
 www.DaltonsWadkin.com

THIRD ANGLE PROJECTION		WADKIN LTD. LEICESTER	
B	DATE: 24.10.75	A	DESCRIPTION: MAINTENANCE OF KUBER PAGED GREASED FOR LIFE FB1 SPINDLE BEG.
DRAWN BY: [Signature]		QTY:	MATERIAL:
CHECKED BY: [Signature]		PART NO: FB 10270	

REPLACEMENT OF PARTS ASSOCIATED WITH THE MOTOR PULLEYS

1. Before access can be made to any belt or pulley it will be necessary to remove the guard covers.
2. Slacken off the tension of motor pulley driving belt. This is effected by loosening the motor fixing bolts on the attendant motor bracket or the motor tensioner bolts whichever apply. The belts can then be removed.
3. To remove cutterblock pulley. In certain instances the cutterblock and motor pulleys have been fitted with taper lock bushes instead of the orthodox keys.

TO REMOVE THE TAPER LOCK BUSH FROM THE PULLEYS.

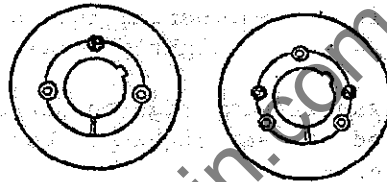
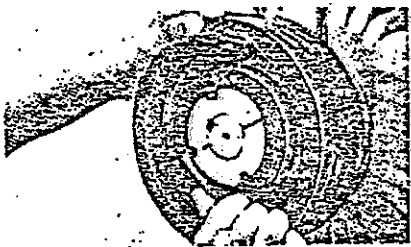

1. Slacken all screws by several turns, remove one or two according to number of jacking off holes shown thus • in diagram. Insert screws in jacking off holes after oiling thread and point of grub screws or thread and under head of cap screws.
2. Tighten screws alternately until bush is loosened in hub and assembly is free on shaft.
3. Remove assembly from shaft.

RE-FITTING THE PULLEYS AND TAPER LOCK BUSHES

1. After ensuring that the mating tapered surfaces are completely clean and free from oil or dirt, insert bush in hub so that holes line up.
2. Oil thread and point of grub screws or thread under head of cap screws. Place screws loosely in holes threaded in hub, shown thus  in diagram.

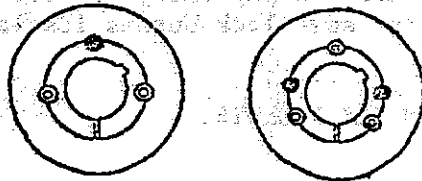

3. Clean shaft and fit hub and bush to shaft as one unit and locate in position desired, remembering that bush will nip the shaft first and then hub will be slightly drawn on to the bush.
4. Using a hexagon wrench, tighten screws gradually and alternately until all are pulled up very tightly. Use a piece of pipe on wrench to increase leverage.
5. After the bush has been tightened on to the shaft fit the parallel key which is side fitting with top clearance.
6. After drive has been running under load for a short time, stop and check tightness of screws.
7. Fill empty holes with grease to exclude dirt.

IMPORTANT:-

Check the condition and tension of the cutterspindle drive BELTS at regular intervals.

FIRST BOTTOM HORIZONTAL HEAD SPINDLES 40mm DIA. WITH SPRING LOADED PERMANENTLY LUBRICATED BEARINGS - SPEED 4500 AND 6000 RPM. FBN 230.

REF.NO.	PART NO.	DESCRIPTION	NO.OFF
* 1	K05 03 128	Screw 1/4in. whit. x 1/2in. countersunk for FB 1747	1
2	K05 19 183	Standard locknut 1.3/4in. for FB 1747	1
3	FB 1713	Outboard bearing end cap	1
4	K05 01 123	Hexagon hole cap screw 1/4in. whit. x 1/2in. long for FB 1713	4
5	FB 1717	Outboard bearing spacing collar	1
6	FB 1715	Outboard bearing oiling collar	1
7	FB 1714	Outboard bearing end cap	1
∅ 8	K06 20 106	Ball bearing RHP 6209 TB EP7	1
9	FB 1747	Outboard bearing sleeve	1
10	FB 1719	Outboard bearing sleeve key	1
* 11	FB 2129	Spindle nut	1
12	FB 2673	Bottom horizontal spindle 40mm dia.	1
13	FAC 13	Locking cone	1
14	FB 1741	Spindle bearing cap	1
15	FB 1740	Locknut for front bearing	1
* 16	K05 03 128	Screws countersunk 1/4in. BSW x 1/2in. long for FB 1740	2
∅ 17	K06 20 110	Ball bearing RHP 6211 TB EP7 KG packed	2
18	FB 3355	Spindle barrel	1
19	FB 1749	Rear bearing end cap	1
20	K05 03 311	Hexagon hole countersunk screws 5/16in. BSW x 1/2in. long for FB 1749	4
21	FB 3348	Rear bearing sleeve	1
22	K05 23 354	Spindle key 3/8in. square x 4in. long	1
23	K05 19 175	Locknut 1.1/2in. ID x 14 TPI right hand	1
24	FB 1526	Spindle pulley	1
25	FB 1750	Spacing collar	1
26	FB 1703	Bearing spacer	1
* 27	K30 77 185	"FENNER" belts "ALPHA" 560	3
28	FW 322	Thrust spring	4
* 29	K05 20 615	Dowel pins 1/4in. dia. x 1.1/4in. long	2

* not shown

∅ KG packed - "KLUBER" grease packed

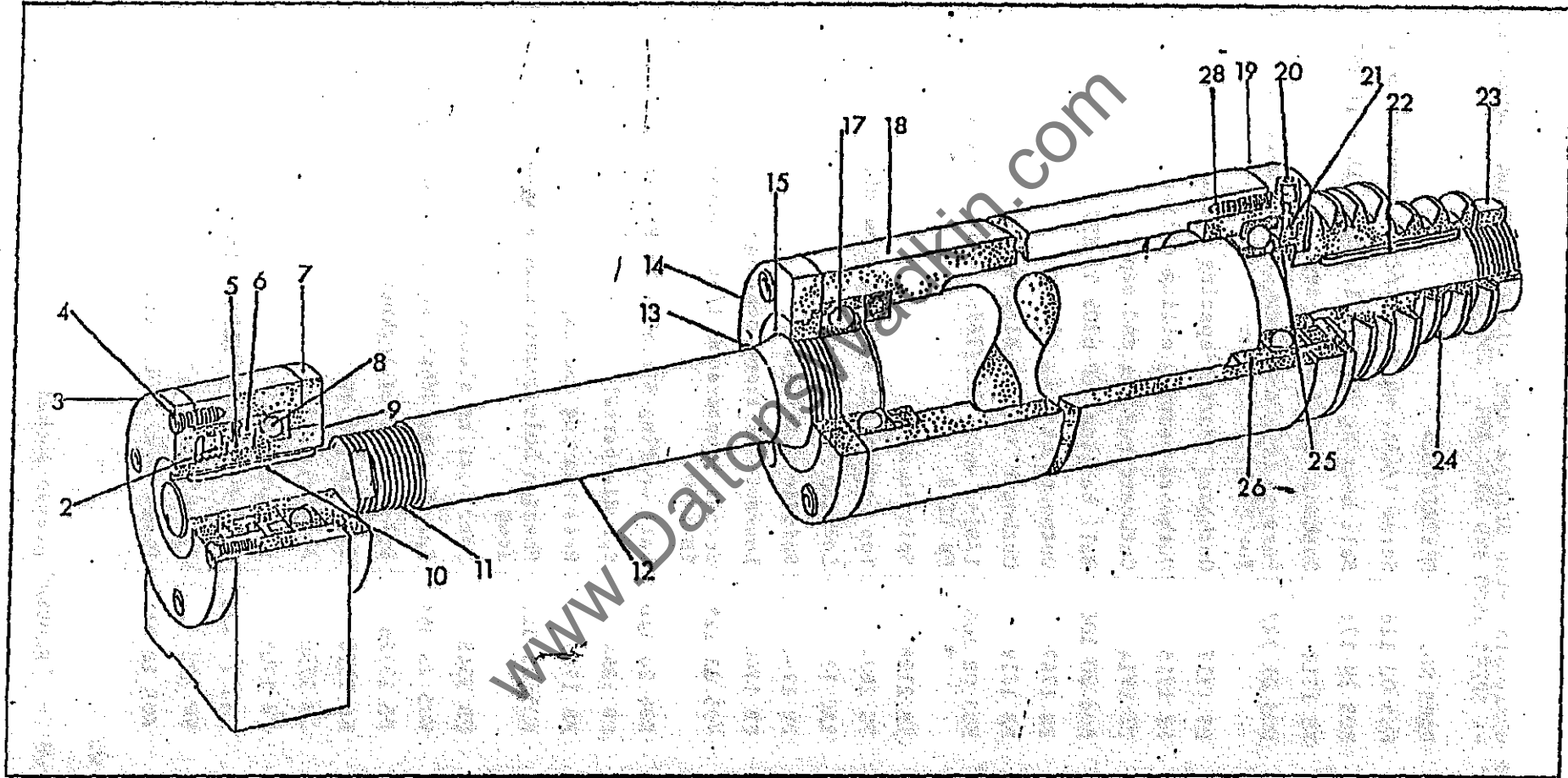

FIRST BOTTOM HORIZONTAL HEAD SPINDLES 40MM DIA. SPEED 4500 OR 6000 RPM.

FIRST TOP HORIZONTAL HEAD SPINDLE 40MM. DIA. WITH SPRING LOADED OIL LUBRICATED BEARINGS - SPEED 4500 AND 6000 RPM. FBN 230.

REF.NO.	PART NO.	DESCRIPTION	NO.OFF
* 1	K05 03 128	Screw 1/4in. whit. x 1/2in. countersunk for FB 1747	1
2	K05 19 175	Ball bearing locknut 1.1/2in. ID x 14 TPI	1
3	FB 1713	Outboard bearing end cap	1
4	K05 01 123	Hexagon hole cap screw 1/4in. whit. x 1/2in. long for FB 1713	4
5	FB 1717	Outboard bearing spacing collar	1
6	FB 1715	Outboard bearing oiling collar	1
7	FB 1714	Outboard bearing end cap	1
∅ 8	K06 20 106	Ball bearing RHP 6209 TB EP7	1
9	FB 1747	Outboard bearing sleeve	1
10	FB 1719	Outboard bearing sleeve key	1
* 10A	K05 02 103	1/8in. whit. x 5/16in. whit. cheesehead screw for FB 1719	1
* 11	FB 2128	Spindle nut	1
12	FB 2674	Top horizontal spindle 40mm dia.	1
13	FAC 13	Locking cone	1
14	FB 1742	Spindle bearing cap	1
15	FB 1740	Locknut for front bearings	1
* 16	K05 03 128	Screws countersunk 1/4in. BSW x 1/2in. long for FB 1740	2
∅ 17	K06 20 110	Ball bearing RHP 6211 TB EP7 KG packed	2
18	FB 3354	Spindle barrel	1
19	FB 1749	Rear bearing end cap	1
20	K05 03 311	Hexagon hole countersunk screws 5/16in. BSW x 1/2in. long	4
21	FB 3348	Rear bearing sleeve	1
22	K05 23 354	Spindle key 3/8in. square x 4in. long	1
23	FB 13124	Spindle pulley locknut	1
24	FB 1526	Spindle pulley	1
25	FB 1750	Spacing collar	1
26	FB 1703	Bearing spacer	1
* 27	K30 77 125	"FENNER" belts "ALPHA" 560	3
* 28	FW 322	Thrust springs	4
* 29	K05 20 615	Dowel pins 1/4in. dia. x 1.1/4in. long	2
* not shown			
∅ KG packed	-	"KLUBER" grease packed	

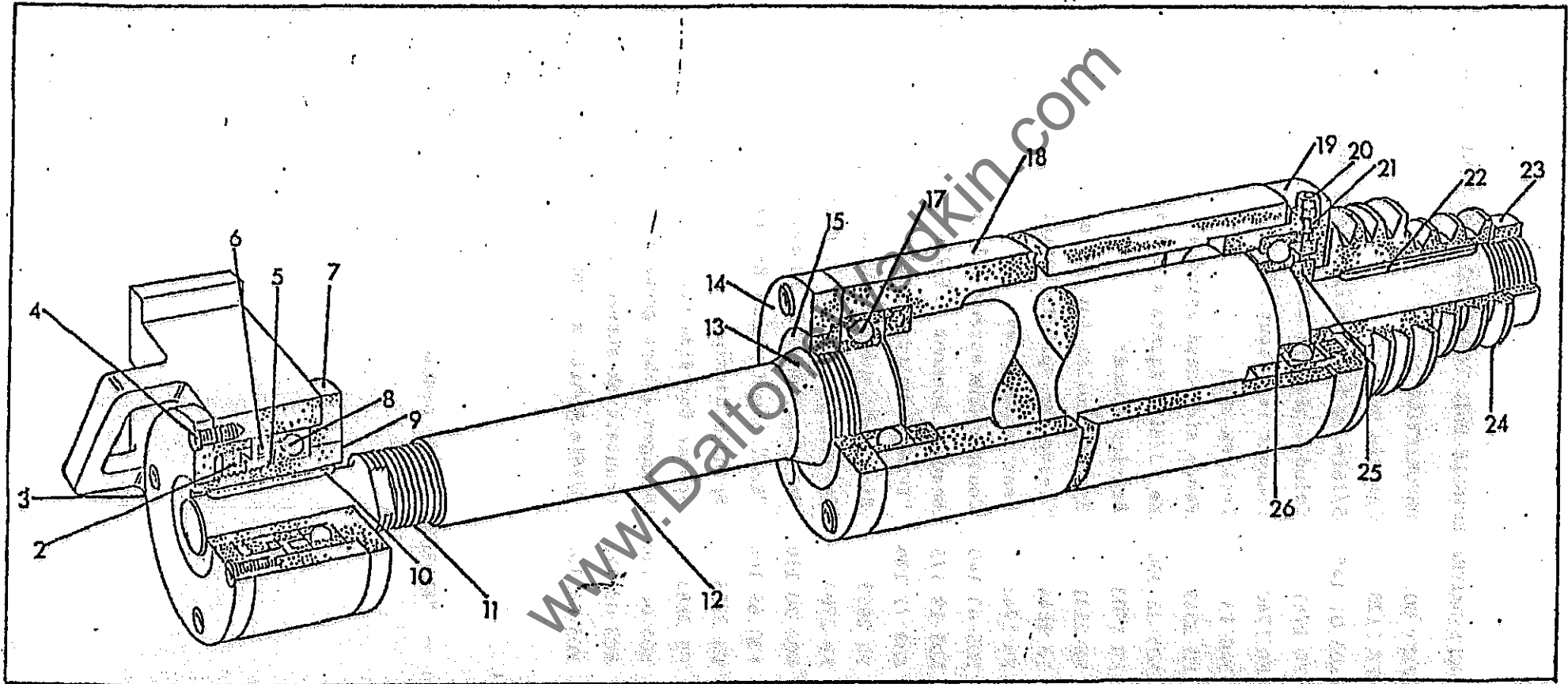

FIRST TOP HORIZONTAL HEAD SPINDLE 40MM.DIA. SPEED 4500 OR 600RPM.

40mm DIA. BELT DRIVEN SPINDLE UNIT FOR FENCE SIDE VERTICAL HEAD. FBN 230.

REF.NO.	PART NO.	DESCRIPTION	NO.OFF
1	FB 2128	Spindle nut	1
2	K05 01 145	5/16in. whit. x 1/2in. long socket head capscrews	4
3	FB 1741	Spindle bearing cap	1
4	FB 1740	Locknut for front bearing	1
5	FAC 13	Locking cone	1
6	FB 3349	Fence side head spindle	1
7	K05 23 330	Key 3/8in. square x 2.3/4in. long	1
8	FB 1703	Bearing spacer	1
9	FB 2131	Spacing collar for cutter spindle	1
* 10	FB 1644	Sleeve for spindle barrel	1
11	FB 1743	Rear bearing cap	1
12	K05-03 140	Countersunk screws 5/16in. whit. x 1/2in. long	4
13	K05 19 175	Bearing locknut 1.1/2in. ID x 14 TPI right hand	1
14	K30 77 126	"FENNER" belts SPZ 1340	2
15	FB 2693	Side head spindle pulley - 50 hertz	1
* 15A	FB 2700	Spindle pulley - 60 hertz	1
∅ 16	K06 20 110	Ball bearing 6211 TB EP7 KG packed	2
17	K30 89 104	"EMO" waved washer EPL 68/L100	1
18	FB 3353	Spindle housing	1
* 19	FB 2183	Spacer for side head spindle pulley	1
* 20	K05 06 140	Hexagon socket grubscrew 3/8in. whit. x 1/2in. long	1
* 21	K05 03 128	Countersunk screws 1/4in. whit. x 1/2in. long	2
* 22	K05 04 101	3/16in. whit. x 3/8in. long round head screws	2

* not shown

∅ KG packed - "KLUBER" grease packed

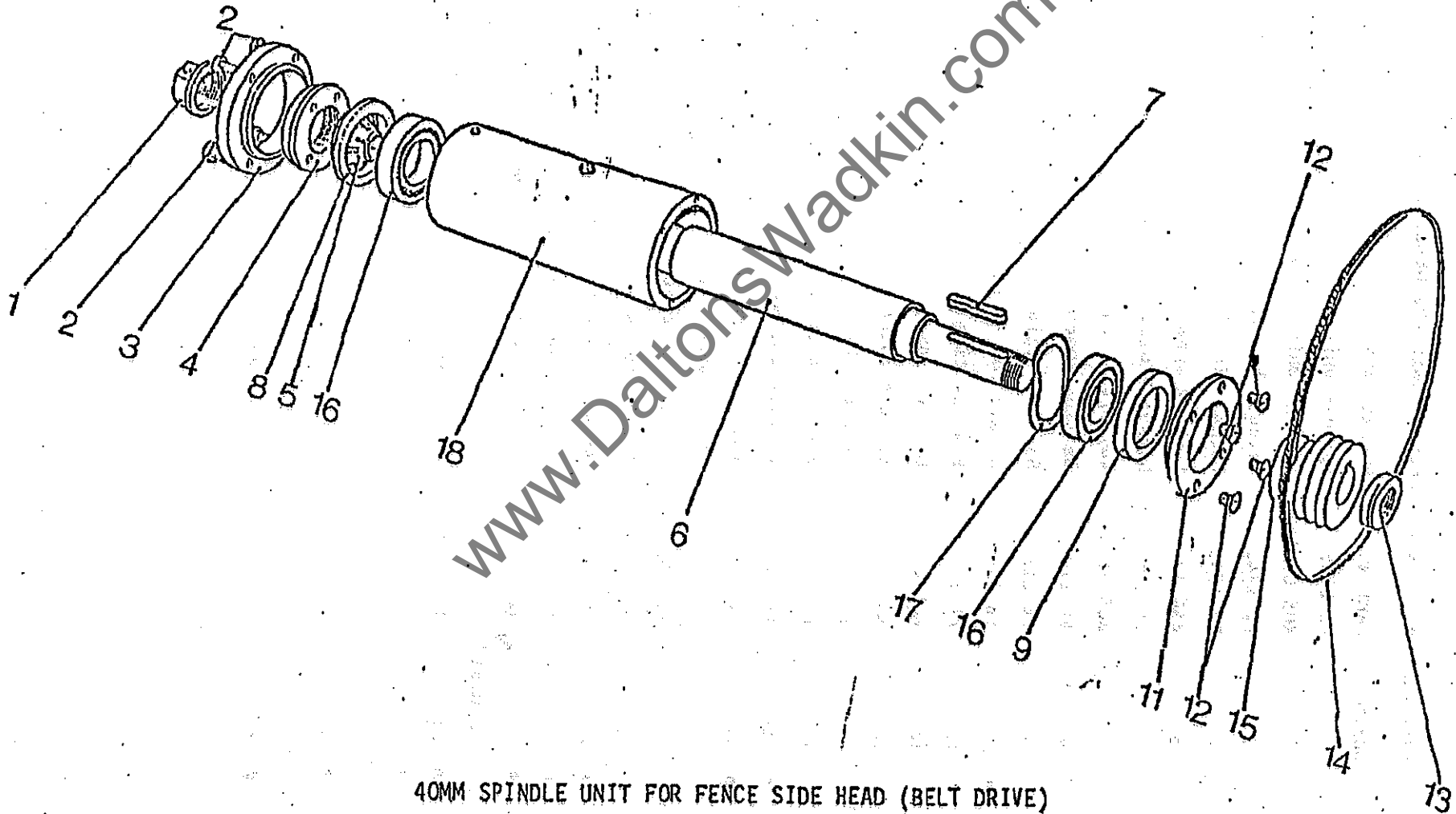

40MM SPINDLE UNIT FOR FENCE SIDE HEAD (BELT DRIVE)

40mm DIA. BELT DRIVEN SPINDLE UNIT FOR NEARSIDE HEAD. FBN 230.

REF.NO.	PART NO.	DESCRIPTION	NO.OFF
1	FB 2129	Spindle unit	1
2	K05 01 145	5/16in. whit. x 1/2in. long socket head capscrew	4
3	FB 1741	Spindle bearing cap	1
4	FB 1740	Locknut for front bearing	1
5	FAC 13	Locking cone	1
6	FB 3351	Nearside head spindle	1
7	K05 23 330	Key 3/8in. square x 2.3/4in. long	1
8	FB 1703	Bearing spacer	1
9	FB 2131	Spacing collar for cutter spindle	1
* 10	FB 1644	Sleeve for spindle barrel	1
11	FB 1743	Rear bearing cap	1
12	K05 03 140	Countersunk screws 5/16in. whit. x 1/2in. long	4
13	K05 19 175	Bearing locknut 1.1/2in. ID 14 TPI right hand	1
14	K30 77 126	"FENNER" belt "ALPHA" SPZ 1340	2
15	FB 2693	Side head spindle pulley - 50 hertz	1
* 15A	FB 2700	Spindle pulley - 60 hertz	1
∅ 16	K06 20 210	Ball bearings 6211 TB EP7 KG packed	2
17	K30 89 104	"EMO" Waved washer EPL 100	1
18	FB 3353	Spindle housing	1
19	FB 2183	Spacer for side head spindle pulley	1
* 20	K05 06 140	Hexagon socket grubscrew 3/8in. whit. x 1/2in. long	1
* 21	K05 04 101	3/16in. whit. x 3/8in. long round head screws	2
* 22	K05 03 128	Countersunk screws 1/4in. whit. x 1/2in. long	2
60 HERTZ			
* 23	FB 2188	Side head spindle pulley	1
* 24	FB 2183	Spacer for side head spindle pulley	1
* not shown			
∅ KG packed - "KLUBER" grease packed			

November, 1979

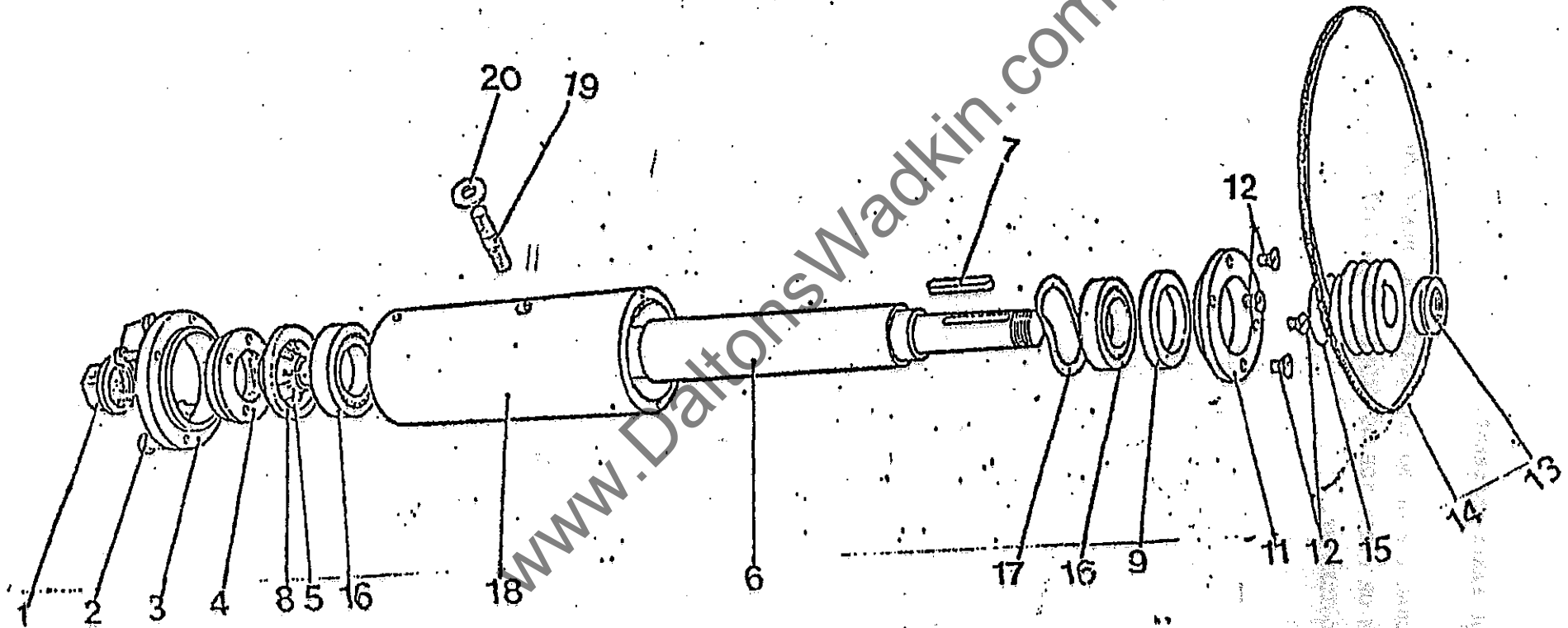

40mm dia. BELT DRIVEN SPINDLE UNIT FOR NEAR SIDE HEAD

NOTE: FOR PARTS REFERENCE

WHEN ADDITIONAL TOP OR BOTTOM HORIZONTAL HEADS ARE SUPPLIED USE EITHER THE FIRST BOTTOM OR FIRST TOP HORIZONTAL HEAD LIST OF PARTS DEPENDENT UPON THE SPECIFIC REQUIREMENT.

www.DaltonsWadkin.com

FIRST BOTTOM HORIZONTAL HEAD SPINDLES 1.13/16IN. DIA. SPRING LOADED PERMANENTLY LUBRICATED BEARINGS - 4500 OR 6000 RPM.

REF.NO:	PART NO:	DESCRIPTION	NO:OFF
* 1	K05 03 128	Screw 1/4in. whit. x 1/2in. countersunk for FB 1747	1
2	K05 19 183	Standard locknut 1.3/4in. for FB.1747	1
3	FB 1713	Outboard bearing end cap	1
4	K05 01 123	Hexagon hole cap screws 1/4in. whit. x 1/2in. long for FB 1713	4
5	FB 1717	Outboard bearing spacing collar	1
6	FB 1715	Outboard bearing oiling collar	1
7	FB 1714	Outboard bearing end cap	1
∅ 8	K06 20 106	Ball bearing R.H.P.6209 TB EP7	1
9	FB 1747	Outboard bearing sleeve	1
10	FB 1719	Outboard bearing sleeve key	1
* 11	FB 2129	Spindle nut	1
12	FB 12547	Bottom horizontal spindle 1.13/16in.dia.	1
13	AGCT 45	Locking cone	1
14	FB 1742	Spindle bearing cap	1
15	FB 1740	Locknut for front bearings	1
* 16	K05 03 128	Screws countersunk 1/4in. B.S.W. x 1/2in. long for FB 1740	2
∅ 17	K06 20 110	Ball bearing R.H.P. 6211 TB EP7 KG.packed	2
18	FB 3354	Spindle barrel	1
19	FB 1749	Rear bearing end cap	1
20	K05 03 311	Hexagon hole countersunk screws 5/16in.B.S.W. x 1/2in. long for FB 1749	4
21	FB 3348	Rear bearing sleeve	1
22	K05 23 354	Spindle key 3/8in. square x 4in. long	1
23	K05 19 175	Locknut 1.1/2in. I.D. - 14 T.P.I. right hand	1
24	FB 2695	Spindle pulley	1
25	FB 1750	Spacing collar	1
26	FB 1703	Bearing spacer	1
* 27	K30 77 125	"FENNER" belts SPZ 1420	4
* 28	FB 2140	Spindle key for cutterblock	1
* 29	K05 02 103	Cheese head screws 1/8in. whit. x 3/4in. long for FB 1719	2
* 30	K05 03 116	Slotted head countersunk screws 3/16in.whit x 1/2in. long for key FB 2140	2
* 31	K05 01 145	Capscrews 5/16in. whit x 1/2in. long for FB 1742	4
* 32	FW 322	Thrust springs	4
* 33	K05 20 615	Dowel pin 1/4in. dia. x 1.1/4in.long	1
* not shown			
∅ KG.packed - "KLUBER" grease packed			

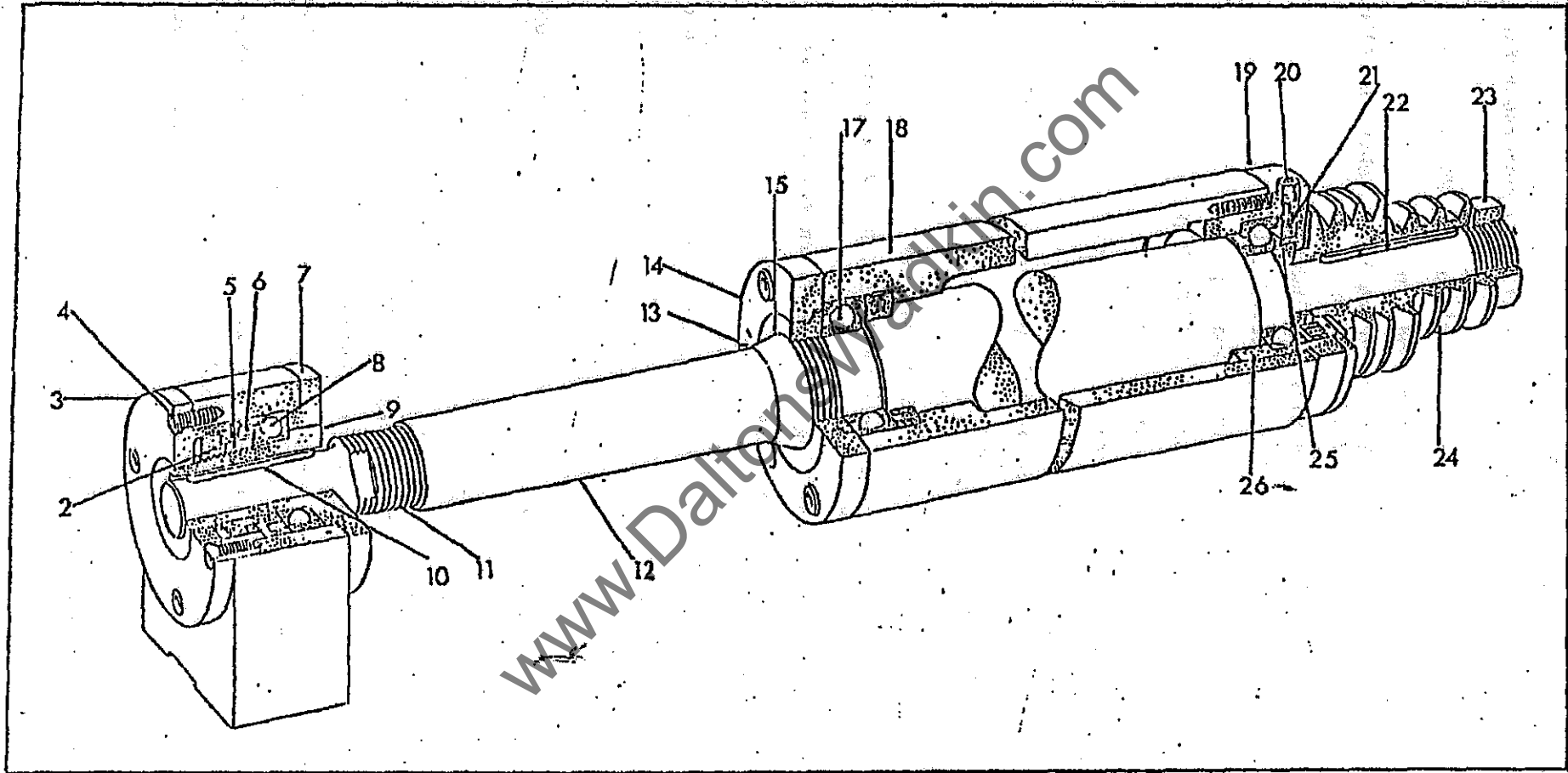

FIRST BOTTOM HORIZONTAL HEAD SPINDLES 1.13/16IN.DIA. 4500 OR 6000 RPM.

FIRST TOP HORIZONTAL HEAD SPINDLE 1.13/16IN. DIA. SPRING LOADED OIL LUBRICATED BEARINGS - SPEED 4500 OR 6000RPM.

REF.NO:	PART NO:	DESCRIPTION	NO:OFF
* 1	K05 03 128	Screw 1/4in.whit. x 1/2in. countersunk for FB 1747	1
2	K05 19 183	Standard locknut 1.3/4in. for FB 1747	1
3	FB 1713	Outboard bearing end cap	1
4	K05 01 123	Hexagon hole cap screw 1/4in.whit. x 1/2in.long for FB 1713	4
5	FB 1717	Outboard bearing spacing collar	1
6	FB 1715	Outboard bearing oiling collar	1
7	FB 1714	Outboard bearing end cap	1
∅ 8	K06 20 106	Ball bearing R.H.P. 6209 TB EP7	1
9	FB 1747	Outboard bearing sleeve	1
10	FB 1719	Outboard bearing sleeve key	1
* 11	FB 2128	Spindle nut	1
12	FB 12548	Top horizontal spindle 1.13/16in.dia.	1
13	AGCT 45	Long cone	1
14	FB 1742	Spindle bearing cap	1
15	FB 1740	Locknut for front bearings	1
* 16	K05 03 128	Screws countersunk 1/4in.BSW. x 1/2in.long for FB 1740	2
∅ 17	K06 20 110	Ball bearing RHP.6211 TB EP7 KG.packed	2
18	FB 3354	Spindle barrel	1
19	FB 1749	Rear bearing end cap	1
20	K05 03 311	Hexagon hole countersunk screws 5/16in.BSW. x 1/2in. long for FB 1749	4
21	FB 3348	Rear bearing sleeve	1
22	K05 23 354	Spindle key 3/8in. square x 4in.long	1
23	K05 19 175	Locknut 1.1/2in. I.D.x 14 T.P.I. - right hand	1
24	FB 2695	Spindle pulley	1
25	FB 1750	Spacing collar	1
26	FB 1703	Bearing spacer	1
* 27	K30 77 125	"FENNER" belts SPZ 1420	4
* 28	FB 2140	Spindle key for cutter block	1
* 29	K05 02 103	Cheese head screw 1/8in.whit. x 3/4in. long for FB 1719	2
* 30	K05 03 116	Slotted head countersunk screws 3/16in. whit x 1/2in. for key FB 2140	2
31	K05 01 145	Cap screws 5/16in. whit. x 1/2in. long for FB 1742	4
* 32	FW 322	Thrust springs	4
* 33	K05 20 615	Dowel pin 1/4in. dia. x 1.1/4in. long	1

* not shown

∅ KG.packed - "KLUBER" grease packed.

November, 1979

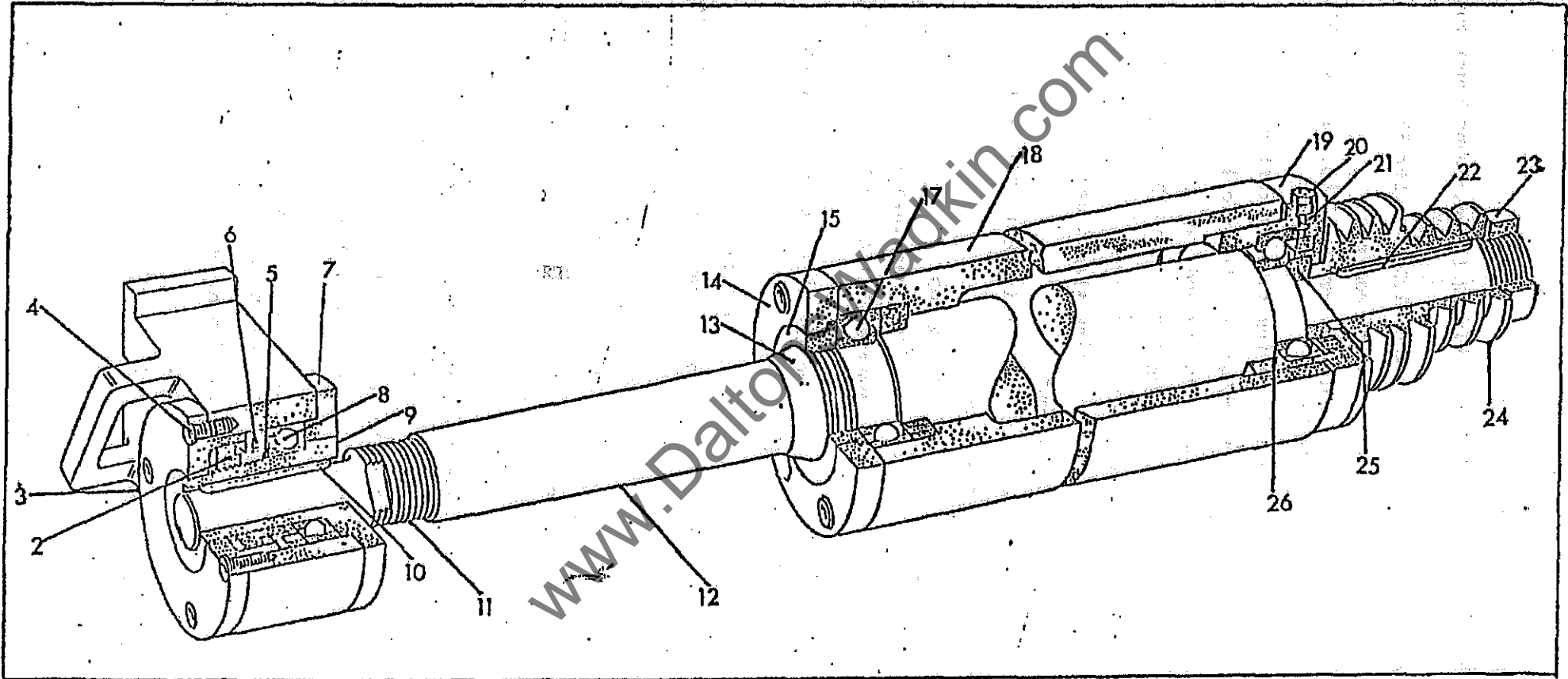

FIRST TOP HORIZONTAL HEAD SPINDLE 1.13/16IN. DIA. 4500 OR 6000 RPM.

1.13/16IN.DIA. BELT DRIVEN SPINDLE UNIT FOR FENCE SIDE VERTICAL HEAD FBN.230

REF.NO:	PART NO:	DESCRIPTION	NO:OFF
1	FB 2128	Spindle nut	1
2	K05 01 145	5/16in. whit. x 1/2in. long socket head capscrews	4
3	FB 1741	Spindle bearing cap	1
4	FB 1740	Locknut for front bearing	1
5	AGCT 45	Locking cone	1
6	FB 3350	Fence side head spindle	1
7	K05 23 330	Key 3/8in. square x 2.3/4in. long	1
8	FB 1703	Bearing spacer	1
9	FB 2131	Spacing collar for cutter spindle	1
* 10	FB 1644	Sleeve for spindle barrel	1
11	FB 1743	Rear bearing cap	1
12	K05 03 140	Countersunk screws 5/16in. whit. x 1/2in. long	4
13	K05 19 175	Bearing locknut 1.1/2in. I.D - 14 T.P.I. right hand.	1
14	K30 77 126	"FENNER" belts SPZ 1340	2
15	FB 2187	Side head spindle pulley	1
∅ 16	K06 20 110	Ball bearing 6211 TB EP7 KG.packed	2
17	K30 89 104	"EMO" waved washer EPL 68/L100	1
18	FB 3353	Spindle housing	1
* 19	FB 2169	Spacer for side head spindle pulley	1
* 20	K05 06 140	Hexagon socket grubscrew 3/8in. whit. x 1/2in. long.	1
* 21	K05 03 128	Countersunk screws 1/4in. whit. x 1/2in. long	2
* 22	K05 04 101	3/16in. whit. x 3/8in. long round head screws.	2
60 HERTZ			
* 23	FB 2188	Side head spindle pulley	1
* 24	FB 2183	Spacer for side head spindle pulley	1
* not shown			
∅ KG. packed - "KLUBER" grease packed.			

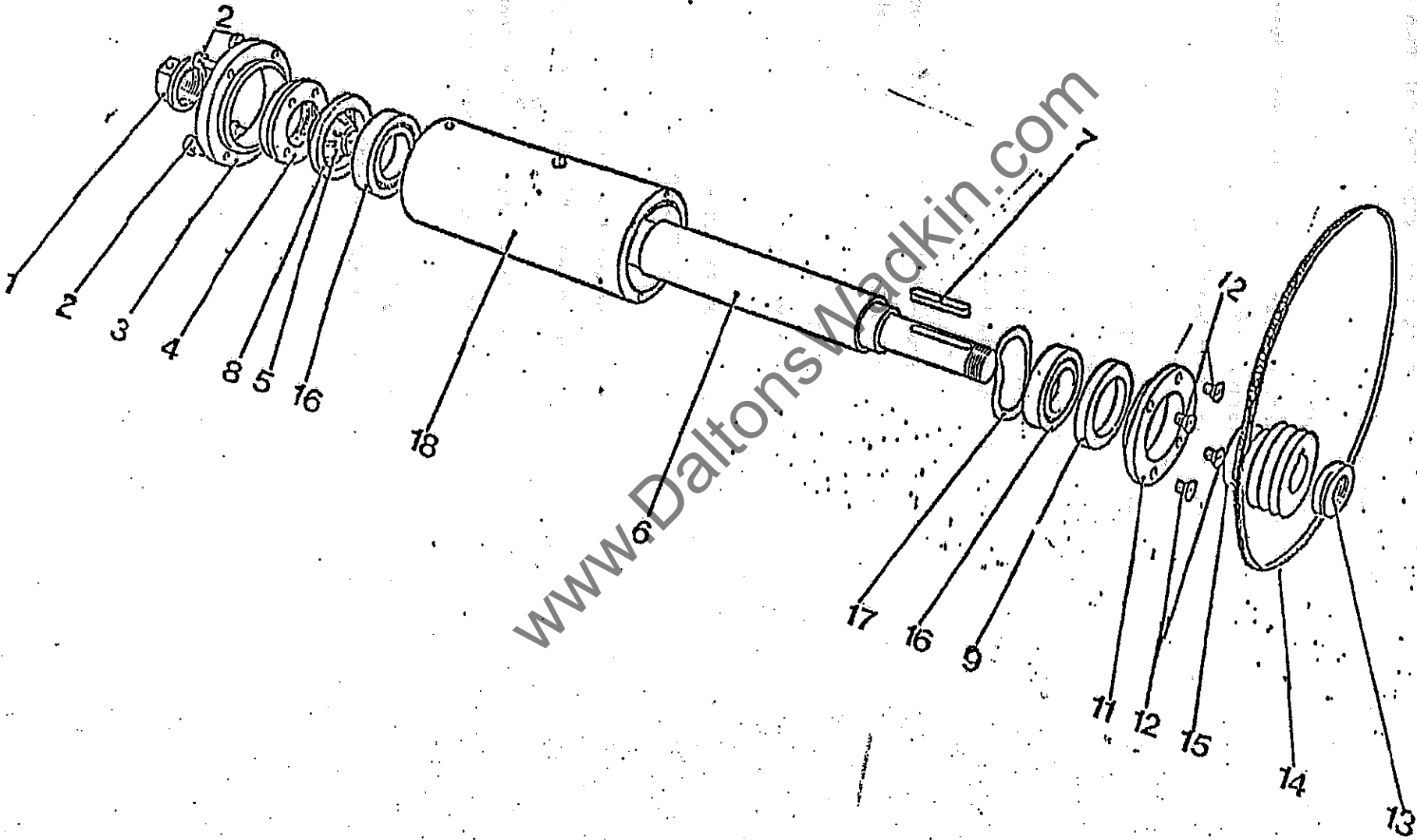

1.13/16in. DIA. SPINDLE UNIT FOR FENCE SIDE HEAD (BELT DRIVE)

1.13/16IN. DIA. BELT DRIVEN SPINDLE UNIT FOR NEAR SIDE HEAD FBN.230

REF.NO:	PART NO:	DESCRIPTION	NO:OFF
1	FB 2129	Spindle nut	1
2	K05 01 145	5/16in. whit. x 1/2in. long socket head capscrews	4
3	FB 1741	Spindle bearing cap	1
4	FB 1740	Locknut for front bearing	1
5	AGCT 45	Locking cone	1
6	FB 3352	Nearside head spindle	1
7	K05 23 330	Key 3/8in. square x 2.3/4in. long	1
8	FB 1703	Bearing spacer	1
9	FB 2131	Spacing collar for cutter spindle	1
* 10	FB 1644	Sleeve for spindle barrel	1
11	FB 1743	Rear bearing cap	1
12	K05 03 140	Countersunk screws 5/16in whit. x 1/2in. long	4
13	K05 19 175	Bearing locknut 1.1/2in. I.D. 14 T.P.I. right hand	1
14	K30 77 126	"FENNER" belt "ALPHA" SPZ 1340	2
15	FB 2187	Side head spindle pulley - 50 hertz	1
∅ 16	K06 20 110	Ball bearings 6211 TB EP7 KG.packed	2
17	K30 89 104	"EMO" waved washer EPL 100	1
18	FB 3353	Spindle housing	1
19	FB 2169	Spacer for side head spindle pulley	1
* 20	K05 06 140	Hexagon socket grubscrew 3/8in. whit. x 1/2in. long.	1
* 21	K05 04 101	3/16in. whit. x 3/8in. long round head screws	2
* 22	K05 03 128	Countersunk screws 1/4in. whit x 1/2in. long	2
60 HERTZ			
* 23	FB 2188	Side head spindle pulley	1
* 24	FB 2183	Spacer for side head spindle pulley	1

* not shown

KG.packed - "KLUBER" grease packed

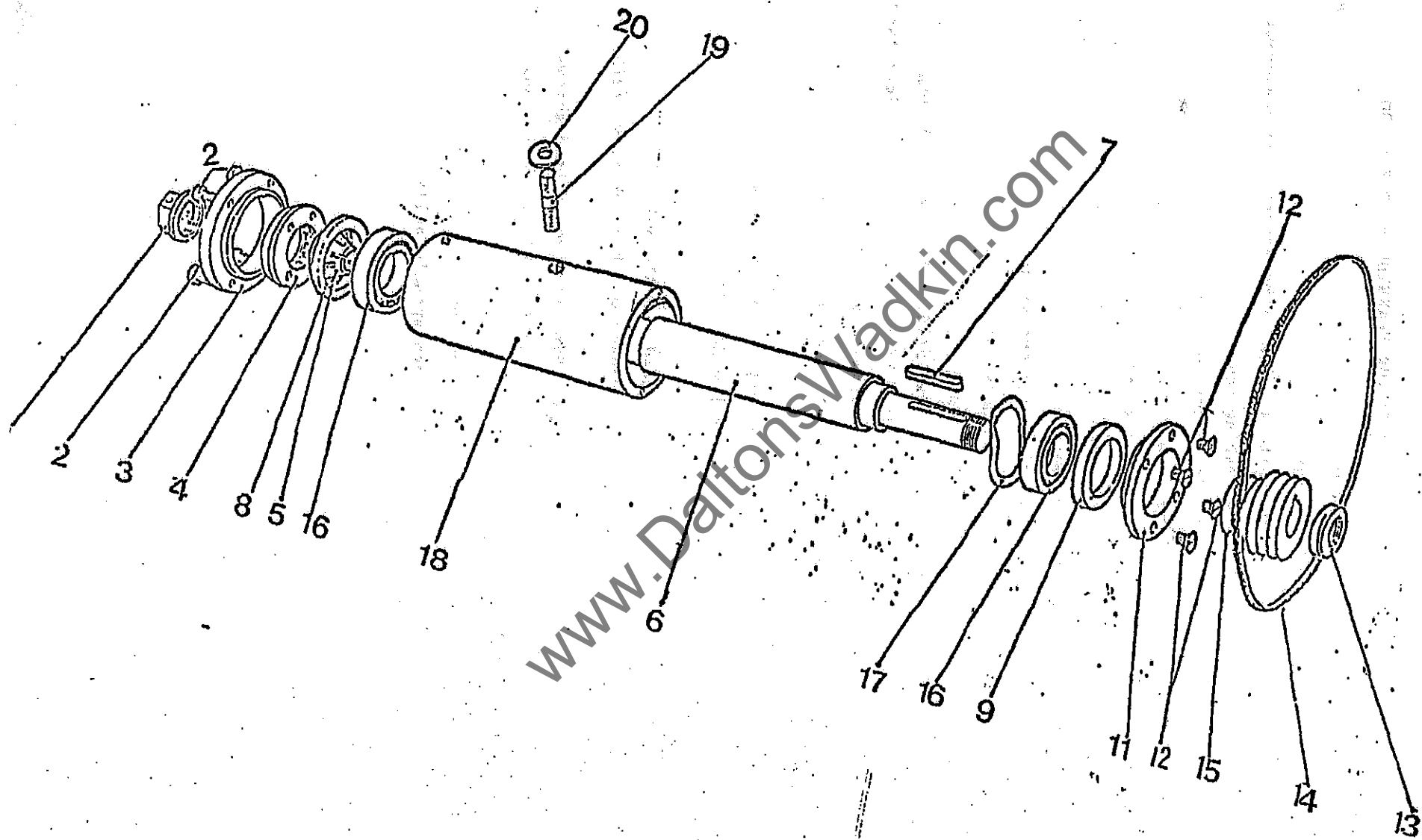

1.13/16in. DIA. SPINDLE UNIT FOR NEARSIDE HEAD (BELT DRIVE)

NOTE:

FOR PARTS REFERENCE AND IDENTIFICATION WHEN ADDITIONAL TOP OR BOTTOM HORIZONTAL HEADS ARE SUPPLIED USE EITHER THE FIRST BOTTOM OR FIRST TOP HORIZONTAL HEAD LIST OF PARTS DEPENDENT UPON THE SPECIFIC REQUIREMENT.

www.DaltonsWadkin.com

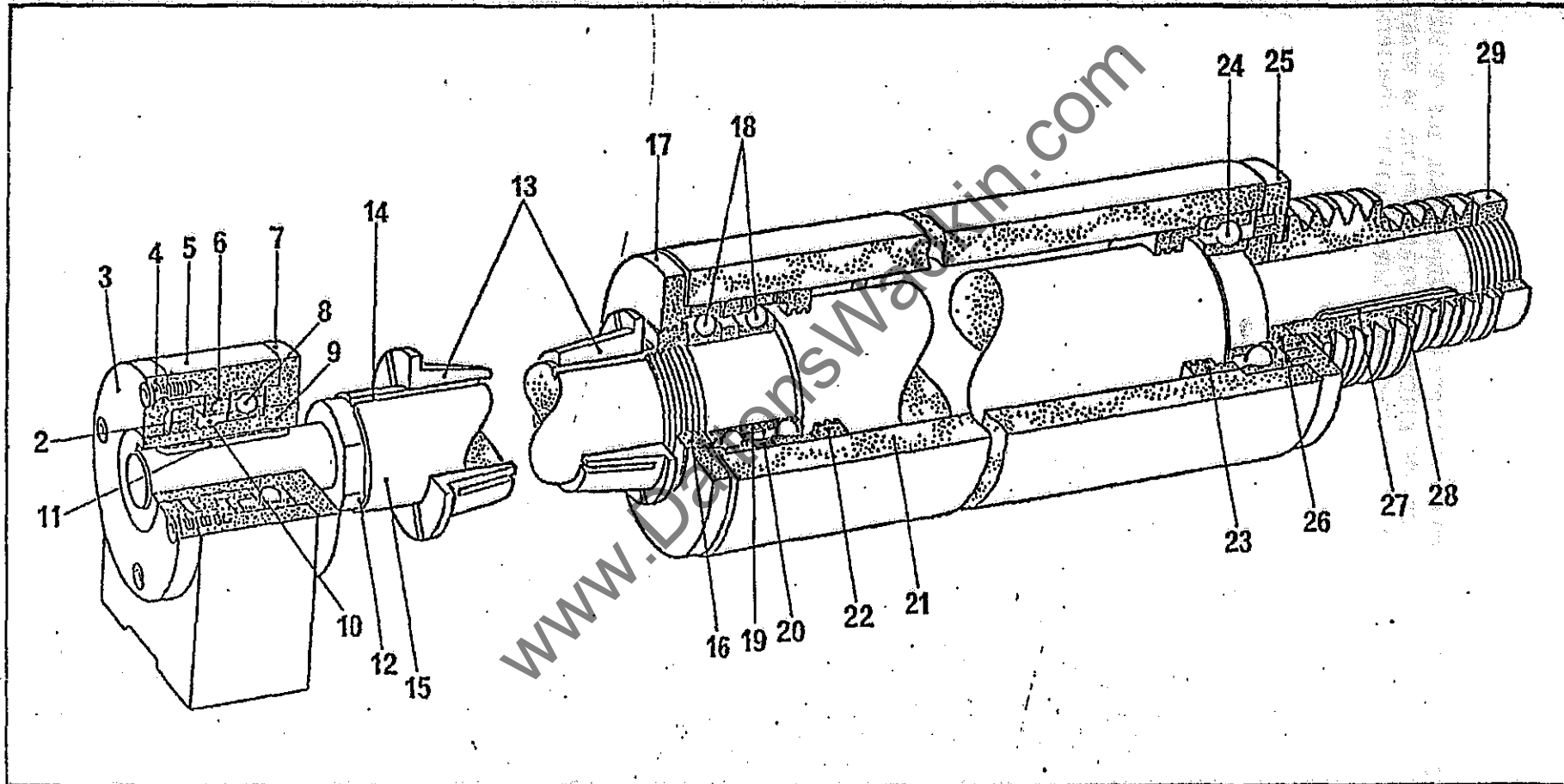

BOTTOM HORIZONTAL HEAD SPINDLE 1.13/16IN. DIA. WITH PERMANENTLY LUBRICATED ANGULAR CONTACT BEARINGS - 4500 OR 6000 R.P.M. SPEED

FAO Clive

BOTTOM HORIZONTAL HEAD SPINDLE 1.13/16in. DIA. WITH PERMANENTLY LUBRICATED ANGULAR CONTACT BEARING - SPEED 4500 OR 6000 RPM.

Ref.No:	Part No:	Description	No.Off
* 1	K05 03 128	Screw 1/4in. x 1/2in. countersunk for FB 1747	1
2	K05 19 185	Standard locknut 1.3/4in. for FB 1747	1
3	FB 1714	Outboard bearing end cap	1
4	K05 01 123	Hexagon hole capscrew 1/4in. whit x 1/2in. long for FB 1713	4
5	FB 12802	Outboard bearing housing	1
6	FB 1715	Outboard bearing oiling collar	1
7	FB 1713	Outboard bearing end cap	1
∅ 8	K06 20 106	Ball bearing R.H.P. TB EP7	1
9	FB 1747	Outboard bearing sleeve	1
10	FB 1717	Outboard bearing spacing collar	1
11	FB 1719	Outboard bearing sleeve key	1
12	FB 13532	Spindle nut	1
13	FCT 28	Locking cones	2
14	FB 13526	Key for cutter spindle	2
15	FB 13519	Bottom horizontal spindle 1.13/16in. dia.	1
16	FB 13539	Locknut for front bearings	1
17	FB 13510	Spindle bearing cap	1
∅ 18	K0620 140	Ball bearing "FAPNIR" 2mm. 9112 WI CR DU M	2
19	FB 13513	Inner bearing spacer	1
20	FB 13512	Outer bearing spacer	1
21	FB 13505	Spindle barrel housing	1
22	FB 13507	Grease retainer	1
23	FB 13507	Grease retainer	1
∅ 24	K06 20 110	Ball bearing R.H.P. 6211 TB EP7	1
25	FB 13508	Rear bearing end cap	1
26	FB 2131	Spacing collar	1
27	K05 23 354	Key for pulley 3/8in. x 3/8in. x 4in. long	1
28	FB 2695	Spindle pulley	1
29	K05 19 177	Locknut 1.1/2in. dia. x 14 T.P.I. right hand	1
* 30	K30 77 125	"FENNER" belts SPZ 1420	4

* not shown

∅ "KLUBER" GREASE PACKED

**TOP HORIZONTAL HEAD SPINDLE 1.13/16in. DIA, WITH PERMANENTLY LUBRICATED
ANGULAR CONTACT BEARINGS - SPEED 4500 OR 6000 RPM.**

Ref.No:	Part No:	Description	No.Off
* 1	K05 03 128	Screw 1/4in. whit. x 1/2in. countersunk for FB 1747	1
2	K05 19 185	Standard locknut 1.3/4in. for FB 1747	1
3	FB 1714	Outboard bearing end cap	1
4	K05 01 123	Hexagon hole capscrew 1/4in. whit x 1/2in. long for FB 1713	4
5	FB 12802	Outboard bearing housing	1
6	FB 1715	Outboard bearing oiling collar	1
7	FB 1713	Outboard bearing end cap	1
∅ 8	K06 20 106	Ball bearing R.H.P.6209 TB EP7	1
9	FB 1747	Outboard bearing sleeve	1
10	FB 1717	Outboard bearing spacing collar	1
11	FB 1719	Outboard bearing sleeve key	1
12	FB 13531	Spindle nut	1
13	FCT 28	Locking cones	2
14	FB 13526	Key for cutter spindle	2
15	FB 13519	Top horizontal spindle 1.13/16in. dia.	1
16	FB 13539	Locknut for front bearings	1
17	FB 13510	Spindle bearing cap	1
∅ 18	K06 20 140	Ball bearings "FAFNIR" 2mm.9112 WI CR DU M	2
19	FB 13513	Inner bearing spacer	1
20	FB 13512	Outer bearing spacer	1
21	FB 13502	Spindle barrel housing	1
22	FB 13507	Grease retainer	1
∅ 23	FB 13507	Grease retainer	1
24	K06 20 110	Ball bearing R.H.P. 6211 TB EP7	1
25	FB 13508	Rear bearing end cap	1
26	FB 2131	Spacing collar	1
27	K05 23 354	Key for pulley 3/8in. x 3/8in. x 4in. long	1
28	FB 2695	Spindle pulley	1
29	K05 19 177	Locknut 1.1/2in. dia. x 14 T.P.I. right hand	1
* 30	K30 77 125	"FENNER" belts SPZ 1420	4

* not shown

∅ "KLUBER" GREASE PACKED

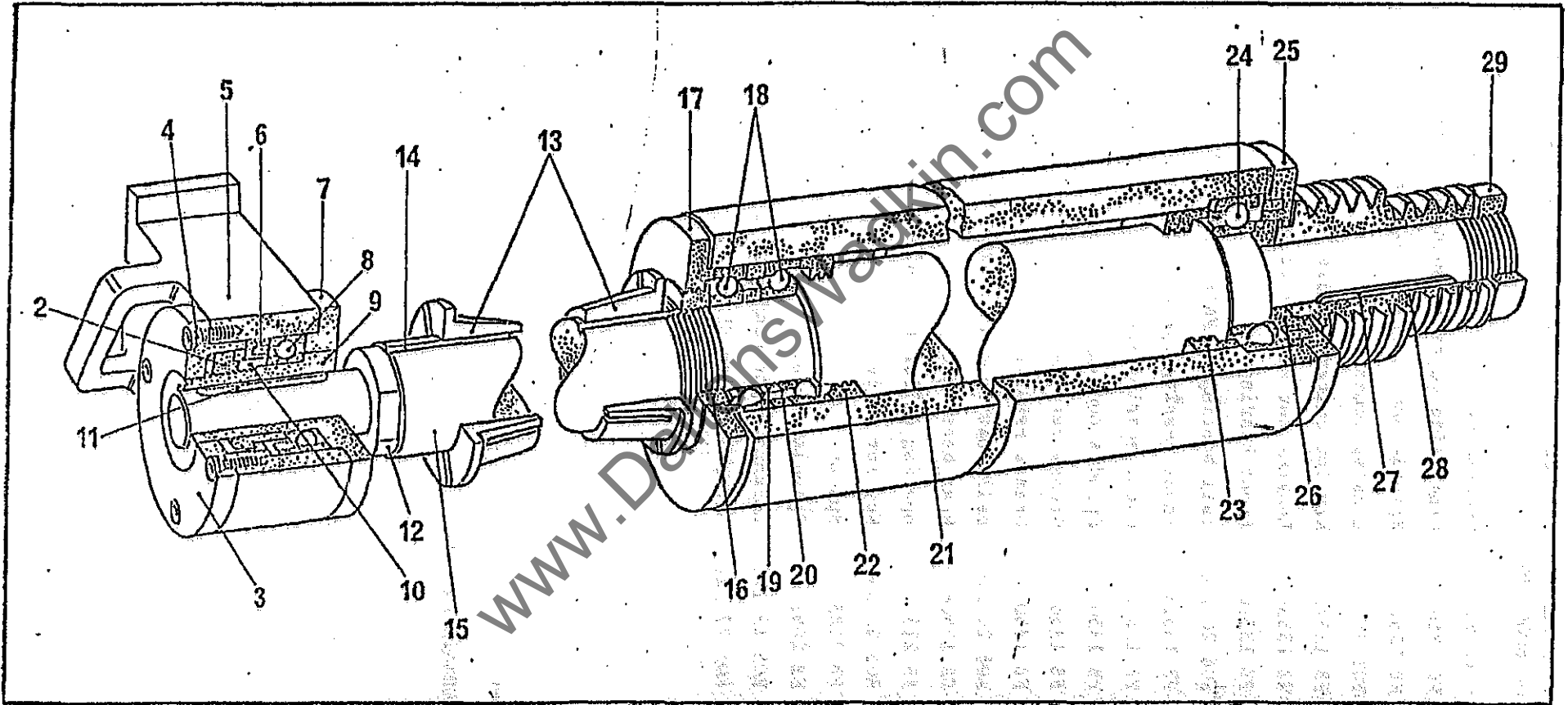

SECOND TOP HORIZONTAL SPINDLE 1.13/16IN. WITH PERMANENTLY LUBRICATED ANGULAR CONTACT BEARINGS 4500 OR 6000 R.P.M.

**FENCE SIDE VERTICAL HEAD SPINDLE 1.13/16in. WITH ANGULAR CONTACT BEARINGS -
SPEED 4500 OR 6000 RPM.**

Ref.No:	Part No:	Description	No.Off
1	FB 13504	Fence side vertical spindle 1.13/16in.dia.	1
* 1a	FB 13511	Spindle nut 1.13/16in dia. x 1.5 pitch right hand	1
2	FCT 28	Locking cones	2
* 2a	FB 13526	Key for cutter spindle	2
3	FB 13539	Locknut for spindle front bearing	1
4	FB 13510	Front bearing cap	1
∅ 5	KO6 20 140	Ball bearing "FAFNIR" 2mm. 9112 W1 CR DU M	2
6	FB 13513	Inner bearing spacer	1
7	FB 13512	Outer bearing spacer	1
8	FB 13501	Spindle housing	1
9	FB 13507	Grease retainer	1
10	FB 13507	Grease retainer	1
∅ 11	KO6 20 110	Ball bearing R.H.P. 6211 TB EP7	1
12	FB 13508	Rear bearing cap	1
13	FB 2131	Spacing collar for spindle	1
14	KO5 23 346	Key for pulley	1
15	FB 2183	Spacer	1
16	FB 2693	Spindle pulley	1
17	KO5 19 175	Locknut right hand pegs 1.1/2in.	1
* 18	KO5 77 125	"FENNER" belts SPZ 1420	2

* not shown

∅ "KLUBER" GREASE PACKED

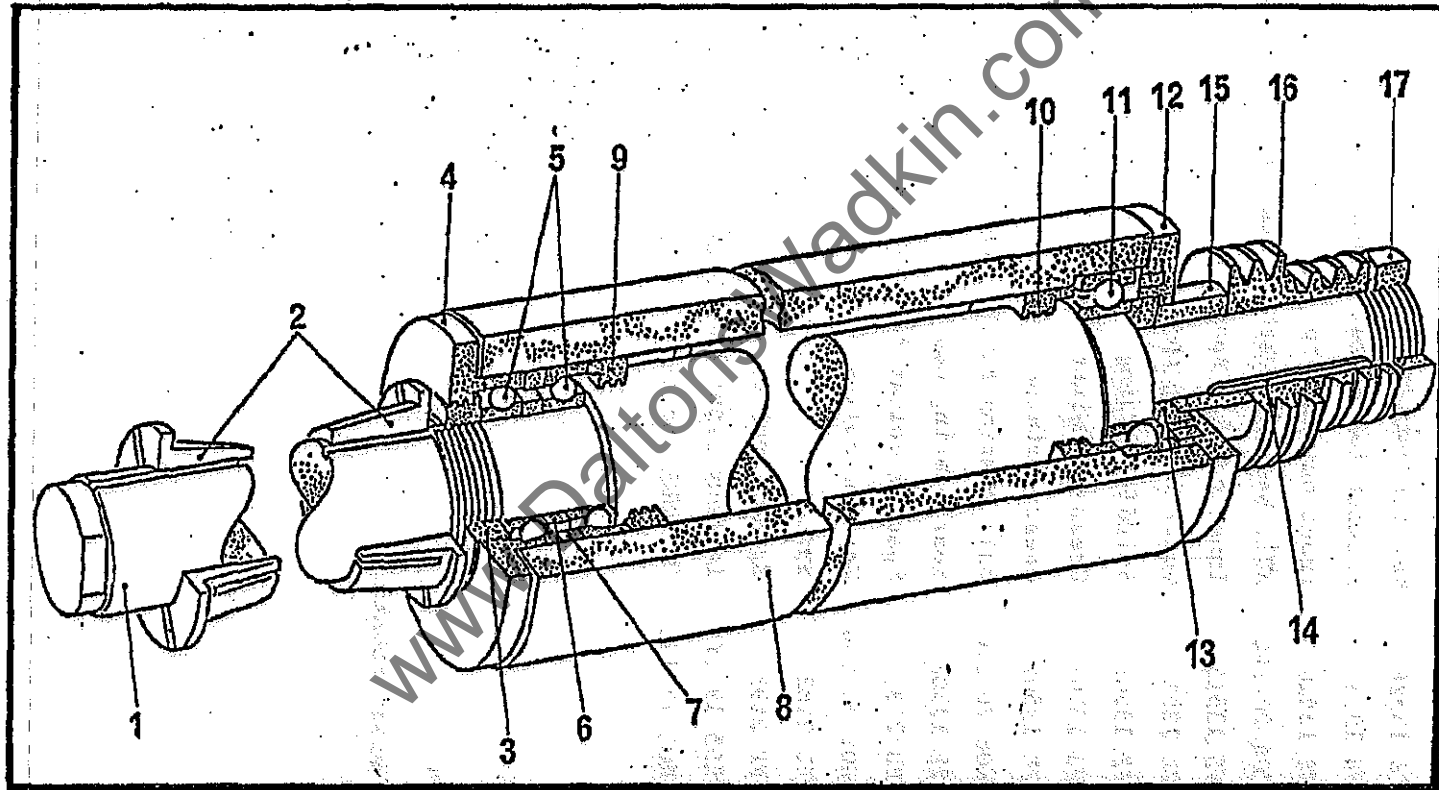

FENCE SIDE VERTICAL HEAD SPINDLE, 4500 OR 6000 RPM.

NEAR SIDE VERTICAL HEAD SPINDLE 1.13/16in. WITH ANGULAR CONTACT BEARINGS -
SPEED 4500 OR 6000 RPM.

Ref. No:	Part No:	Description	No.Off
1	FB 13504	Near side vertical spindle 1.13/16in. dia,	1
* 1a	FB 13511	Spindle nut 1.13/16in. dia. x 1.5 pitch right hand	1
2	FCT 28	Locking cones	2
* 2a	FB 13526	Key for cutter spindle	2
3	FB 13539	Locknut for spindle front bearing	1
4	FB 13510	Front bearing cap	1
∅ 5	KO6 20 140	Ball bearing "FAFNIR" 2mm. 9112 WI CR DU M	2
6	FB 13513	Inner bearing spacer	1
7	FB 13512	Outer bearing spacer	1
8	FB 13501	Spindle housing	1
9	FB 13507	Grease retainer	1
10	FB 13507	Grease retainer	1
∅ 11	KO6 20 110	Ball bearing R.H.P. 6211 TB EP7	1
12	FB 13508	Rear bearing cap	1
13	FB 2131	Spacing collar for spindle	1
14	KO5 23 346	Key for pulley	1
15	FB 2183	Spacer	1
16	FB 2693	Spindle pulley	1
17	KO5 19 175	Locknut right hand pegs 1.1/2in.	1
* 18	KO5 77 125	"FENNER" belts SPZ 1420	2

* not shown

∅ "KLUBER" GREASE PACKED

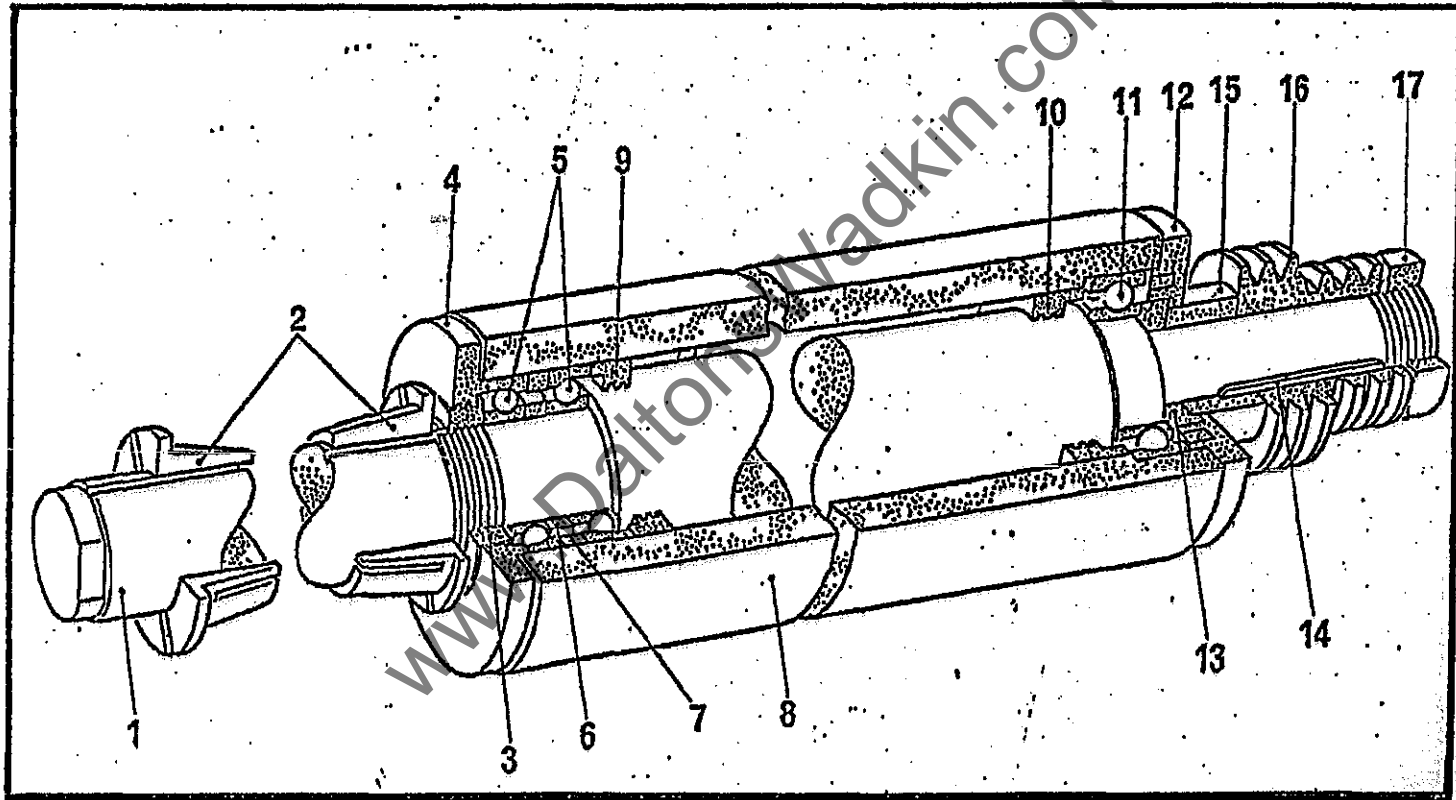

NEAR SIDE VERTICAL HEAD SPINDLE 4500 OR 6000 RPM.

NOTE:-

FOR PARTS REFERENCE AND IDENTIFICATION WHEN ADDITIONAL TOP OR BOTTOM HORIZONTAL HEADS ARE SUPPLIED USE EITHER THE FIRST TOP OR FIRST BOTTOM HORIZONTAL HEAD LIST OF PARTS DEPENDENT ON THE SPECIFIC REQUIREMENT.

www.DaltonsWadkin.com

BELT DRIVEN 40mm dia. SPINDLE UNIVERSAL HEAD WITH SPRING LOADED DEEP GROOVE BALL BEARINGS

Ref.No.	Part No.	Description	No. Off
1	K05 03 129	1/4in. whit. x 5/8in. long counter-sunk head screw	4
2	FW 307	End cover	1
3	FB 1436	Spindle locknut	2
4	FW 306	Rear bearing washer	1
5	FB 1465	Rear end cap	1
6	FW 322	Thrust springs	4
7	K06 05 145	Ball bearings (Hoffman 155)	2
8	FB 1456	Bearing sleeve for spring loaded spindle	1
9	FW 906	Universal head spindle	1
10	FB 1375	Key for universal head spindle	1
11	K06 01 101	3/16in. whit. x 1/2in. long socket head capscrews	4
12	FB 1374	Key for universal head spindle	2
13	FW 985	Spacing collar	1
14	FB 1466	Universal head spindle pulley	1
15	FB 1454	Spacer (inner) and grease retainer	1
16	FB 1453	Spacer (outer)	1
17	FW 310	Inner bearing spacer	1
18	FB 1740	Locknut for front bearing	1
19	FB 1455	Front end cap	1
20	K05 06 133	5/16in. whit. x 1.1/4in. long socket head capscrew	4
21	FB 1457	Locking collar	1
22	FB 1458	Peg for collar	2
23	FB 2126	Spindle nut	1
24	FAC 13	Locking cone	1
25	FB 1364	Spindle housing for Universal Head	1
60 hertz			
* 26	FB 1467	Spindle pulley (not shown)	1
27	K30 77 208	Timing belt Fenner 360 H100	1
50 hertz			
28	FB 1466	Spindle pulley	1
29	K30 77 174	Timing belt 390 H100	1

* Not shown

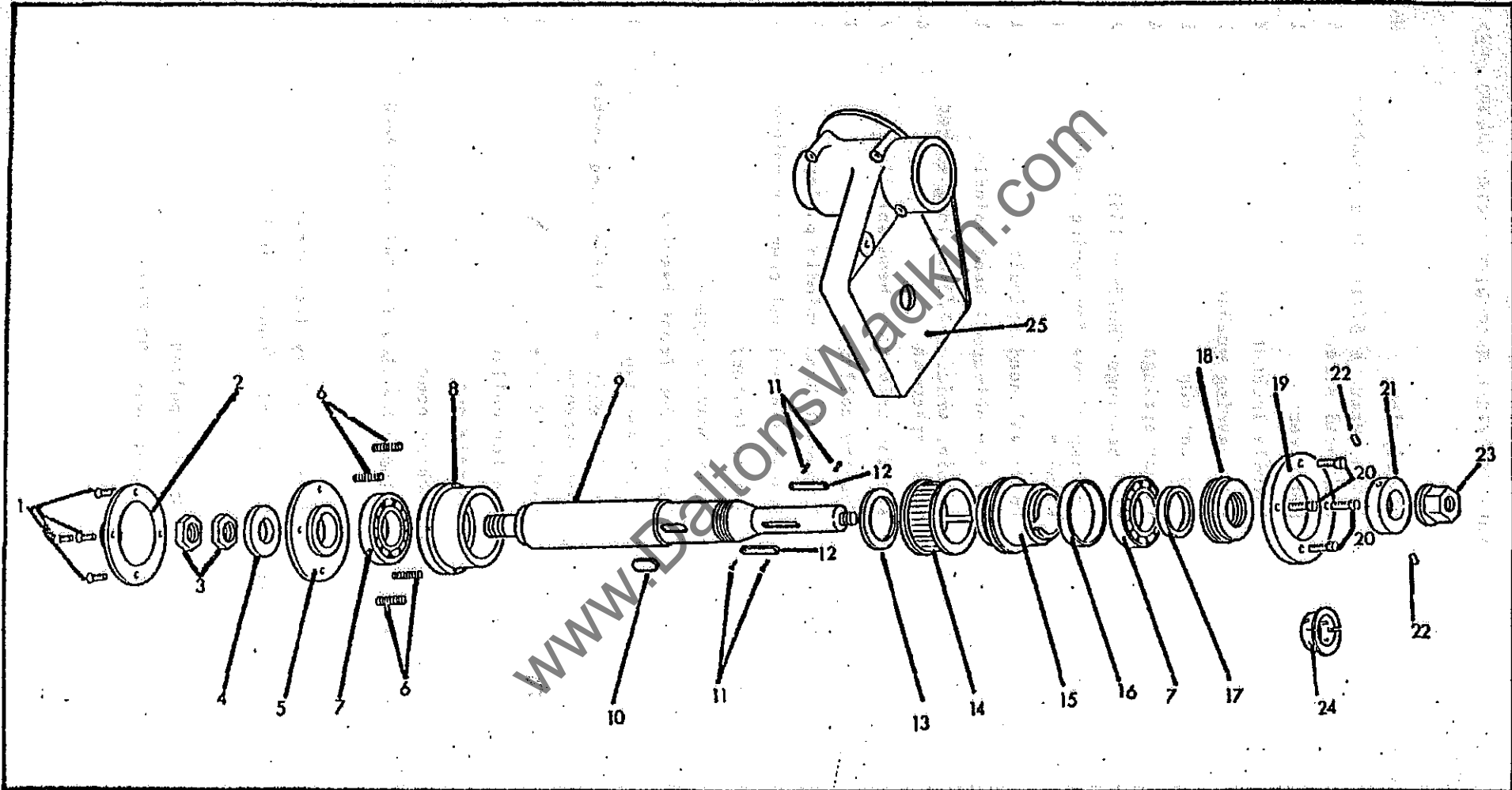

SPRING LOADED UNIVERSAL HEAD SPINDLE

FBN 230 (9in.) GEARBOX

Ref.No.	Part No.	Description	No. Off
1	K05 21 462	1.1/2in. dia. ball knob black 1/2in. BSW Rencol 282	1
2	FB 12069	Gear change lever	1
3	FB 12068	Pivot pin for selector arm	1
4	FB 12005	Gear selector arm	1
5	K30 09 103	Salter external circlip 5100-100A	2
6	FB 12054	Gear selector shaft	1
7	FB 12082	Gear selector	1
8	FB 12057	Guide shaft for gear selector	1
9	K05 20 507	1/4in. dia. x 2in. long No. 4 Taper pin	1
10	FB 12070	Pin for selector	1
11	K30 05 302	3/8in. dia. steel ball	1
12	FB 12073	Spring for selector	1
13	K05 01 152	5/16in. x 1.3/4in. long hexagon socket capscrew	1
14	K05 19 169	1.1/4in. ball bearing locknut R.H. pegs	1
15	FB 12203	Gearbox input pulley 2 step - 50 cycles	1
	FB 12204	Gearbox input pulley 2 step - 60 cycles	1
16	FB 12067	Spacing sleeve (input)	1
17	K30 73 212	Weston oil seal W 20515727 R4	1
18	K05 01 103	3/16in. B.S.W. x 3/4in. long hexagon socket capscrews	3
19	FB 12056	End cap for input shaft	1
20	K06 15 149	Nadella needle bush DL 4020/35	1
21	FB 12053	Input shaft	1
22	FB 12081	Gear cluster for input shaft	1
23	K30 09 141	Salter internal circlip N244	1
24	K06 01 212	RHP bearing 6206	1
25	K05 19 169	1.1/4in. ball bearing locknut R.H. pegs	1
26	FB 12004	End cap	1
27	K05 03 131	1/4 in. BSW x 1 in. long countersunk head slotted screws	3
28	K05 03 131	1/4in. BSW x 1in. long countersunk head slotted screws	3
29	FB 12004	End cap	1
30	K05 19 161	1in. ball bearing locknut R.H. pegs	1
31	K06 01 212	RHP bearing 6206	1
32	FB 12066	Spacing collar (intermediate)	1
33	K30 09 141	Salter internal circlip N244	1
34	FB 12080	Constant mesh gear for intermediate shaft	1
35	FB 12079	Gear for intermediate shaft, high speed range	1

FBN 230 (9in.) GEARBOX (cont.)

Ref.No.	Part No.	Description	No. Off
36	FB 12078	Gear for intermediate shaft, low speed range	1
37	FB 12052	Intermediate shaft	1
38	K06 15 124	Ina bearing HK 4520	1
38a	K06 16 181	Ina inner race I.R. 40 x 45 x 20.5mm	1
39	K30 09 156	Salter external circlip 5100 156A	1
40	FB 12065	Spacing collar (output)	1
41	K06 15 138	INA bearing BK 4520	1
41a	K06 16 181	INA Inner race I.R. 40 x 45 x 20.5mm	1
42	FB 12064	Spacing collar (output)	1
43	FB 12077	Constant mesh gear for output shaft	1
44	FB 12051	Output shaft	1
45	K30 09 283	Salter internal circlip No. 334	1
46	K06 01 234	RHP bearing 6209	1
47	K30 73 211	Weston oil seal W29521647 R4	1
48	FB 12055	End cap for output shaft	1
49	K05 01 125	1/4in. BSW x 3/4in. long hexagon socket capscrews	3
50	FB 12063	Sprocket (output shaft)	1
51	K09 19 169	1.1/4in. ball bearing locknut R.H. pegs	1

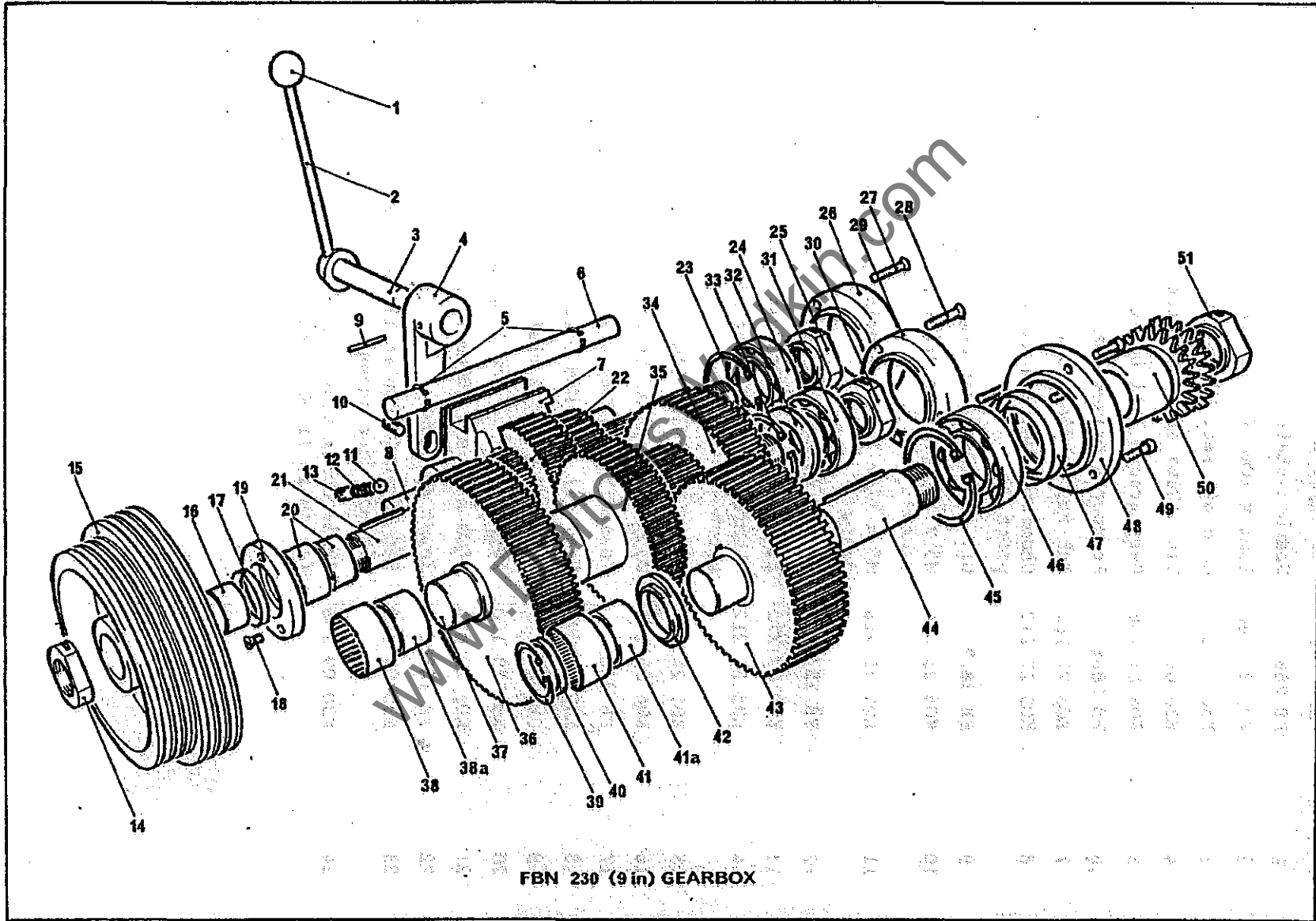

FBN 230 (9 in) GEARBOX

GEARBOX FOR ENCLOSED FEEDWORKS

Ref. No.	Part No.	Description	No. Off
1	FB 2887	Gearbox shaft	4
2	K05 23 180	16mm x 10mm x 63mm long key	4
3	K30 74 297	Gaco oil seal MIM 65100	4
4	K30 09 275	Dia. 100mm internal circlip	8
5	K06 01 248	Deep groove ball bearing	10
6	FB 2868	Feedworks driven gear	4
7	K05 27 261	Tab washer dia. 55mm	4
8	K05 27 212	Chamfered notched nut M55 x 1.5mm pitch	4
9	FB 2879	Oil retainer/dust seal	4
10	K05 25 416	M5 x 12 long posidrive pan head screw	16
11	K05 25 416	M5 x 12mm long posidrive pan head screw	4
12	FB 2879	Oil retainer/dust seal	1
13	K30 09 275	Dia. 100mm internal circlip	2
14	K05 27 212	Chamfered notched nut M55 x 1.5mm pitch	1
15	K05 27 261	Tab washer dia. 55mm	1
16	K06 01 248	Deep groove ball bearing	2
17	FB 2869	Feedworks driving gear	1
18	K30 74 297	Gaco oil seal MIM 65100	1
19	FB 2888	Gearbox sprocket shaft	1
20	K05 23 180	16mm x 10mm x 63mm long key	1
21	K05 23 614	18mm x 11mm x 100mm long key	1
22	FB 14208	Input sprocket	1
23	K30 09 340	Renold chain Duplex 114-046 96 pitches (not shown)	1
24	K30 09 348	Chain Connecting Link No. 26 for chain 114-046 (not shown)	1

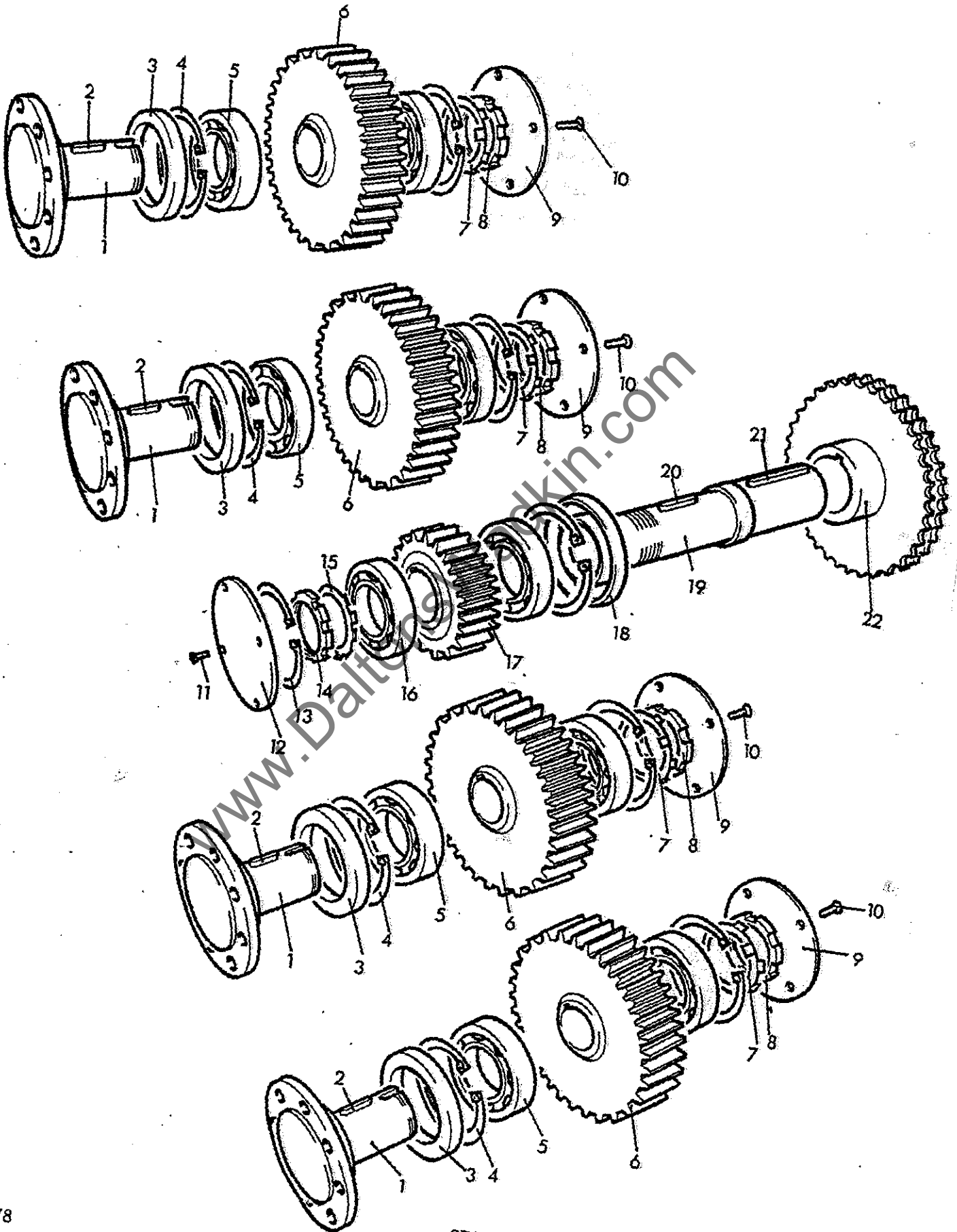

Jan. '78

GEARBOX FOR ENCLOSED FEEDWORKS

TOP COVER FOR ENCLOSED FEEDWORKS

Ref. No.	Part No.	Description	No. Off
1	FB 2910	Top cover for feedworks	1
2	K30 61 263	Norgren miniature pressure gauge (0.160 P.S.I.) 304 M 160	2
3	K05 25 415	M5 x 10mm long posidrive pan head screws	4
4	FB 2909	Guard (timber)	1
5	FB 14028	Control panel	1

www.DaltonsWadkin.com

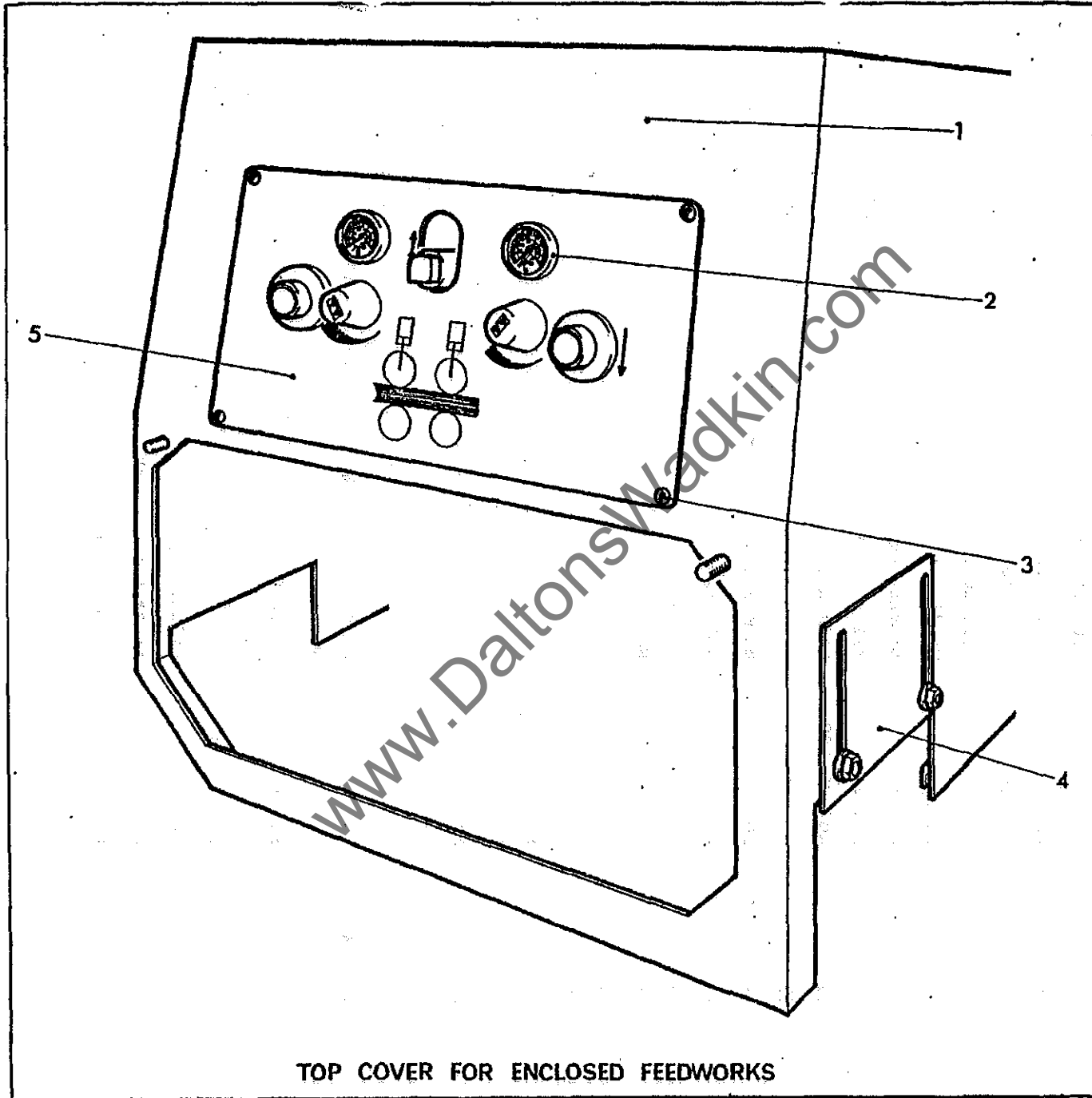

TOP COVER FOR ENCLOSED FEEDWORKS

ENCLOSED FEEDWORKS (TOP)

Ref.No.	Part No.	Description	No. Off
1	K05 27 114	M24 thin nut	2
2	FB 2983	Spacer for raising screw	1
3	K06 10 213	INA Needle thrust bearing AXK 2542	1
4	K06 10 254	INA Thrust washer A.S. 2542	2
5	K05 31 577	I.D. 25 x O.D. 30 x 25 long bush	1
6	FB 14037	Square drive extension for top feedrolls	1
7	K05 20 505	No. 2 Taper pin	1
8	K05 31 564	I.D. 20 x O.D. 25 x 20 long bush	1
9	FB 2871	Winding shaft for top bevel gears	1
10	FB 2861	Bracket for top feedworks adjustment	1
11	K05 25 544	M12 x 30 hexagon head screw	4
12	K05 29 158	10mm dia. x 30mm long dowel	2
13	FB 2866	Cover for bevel gears bracket	1
14	K05 25 415	M5mm x 10mm pan head screw	4
15	K06 10 254	INA thrust washer A.S. 2542	2
16	K06 10 213	INA needle thrust bearing AXK 2542	1
17	K05 20 508	No. 5 Taper pin	1
18	FB 2865	Bevel gear for rise and fall of feedworks	1
19	K05 31 564	I.D. 20 x O.D. 25 x 20 long bush	1
20	K06 10 212	INA Needle thrust bearing AXK 2035	1
21	K06 10 252	INA Thrust washer AS 2035	2
22	FB 2864	Bevel gear for rise and fall of feedworks	1
23	K05 20 505	No. 2 Taper pin	1
24	FB 3021	Raising screw for top feedworks	1
25	K05 25 192	M8mm x 45mm long socket head capscrew	4
26	FB 2867	Nut for top feedworks	1
27	K30 61 606	Atlas Copco cylinder type C.O.D. 300 1.1/2in. stroke	2
28	K05 25 233	M12 x 40mm long socket head capscrew	2
29	FB 2873	Cylinder pivot pin	2
30	K30 61 607	Atlas Copco Locknut 9141 - 1000	2
31	K05 25 240	M12mm x 75mm long socket head capscrew	3
32	K05 29 158	10mm dia. x 30mm long dowel	2
33	FB 14031	Pivot pin for top feedworks swing	1
34	FB 14006	Swings pivot bracket for top feedworks	1
35	FB 14012	Pivot pin support for top feedworks swings	1
36	K05 25 235	M12 x 50long socket head capscrew	3

ENCLOSED FEEDWORKS (TOP) cont.

Ref.No.	Part No.	Description	No. Off
37	K05 29 173	12mm dia. x 40mm long dowel	2
38	K05 25 168	M6 x 30mm long socket head capscrew	8
39	FB 14035	Bearing end cap	2
40	K05 27 212	M55 x 1.5 notch nut	2
41	K05 27 261	55mm dia. tab lockwasher	2
42	K06 01 130	Bearing SKF 6011 2 R.S.	2
43	FB 14036	Bearing sleeve	2
44	FB 14011	L.H. front swing for top feedrolls	1
45	K05 25 233	M12 x 40mm long socket head capscrew	3
46	FB 14010	R.H. front swing for top feedrolls	1
47	K05 25 235	M12 x 50mm long socket head capscrew	3
48	K05 31 592	I.D. 40mm x O.D. 46mm x 30mm long bush	2
49	K05 27 162	Philidas nut (M42 x 4.5) type 42 MCl	2
50	*	Feedroll	8
51	K05 27 212	M55mm x 1.5 notch nut	2
52	K05 27 261	55mm dia. tab lockwasher	2
53	K06 01 130	Bearing SKF 6011 2 R.S.	2
54	K05 31 580	I.D. 40mm x O.D. 46mm x 25mm long bush	4
55	FB 14007	L.H. rear swing for top feedrolls	1
56	FB 14008	R.H. rear swing for top feedrolls	1
57	FB 2878	Bearing spacing sleeve	2
58	K06 01 130	Bearing SKF 6011 2 RS	2
59	FB 14038	Rear swing cylinder pin for top feedrolls	2
60	K05 31 589	I.D. 25mm x O.D. 30mm x 30mm long bush	2
61	FB 14039	Cylinder pivot block for top feedrolls	2
62	FB 14021	Feedroll shaft	2

*FEED ROLLERS (4 off each spindle)

Part No.	Description
FB 14043	Plain feed roller
FB 14047	Knurled feed roller

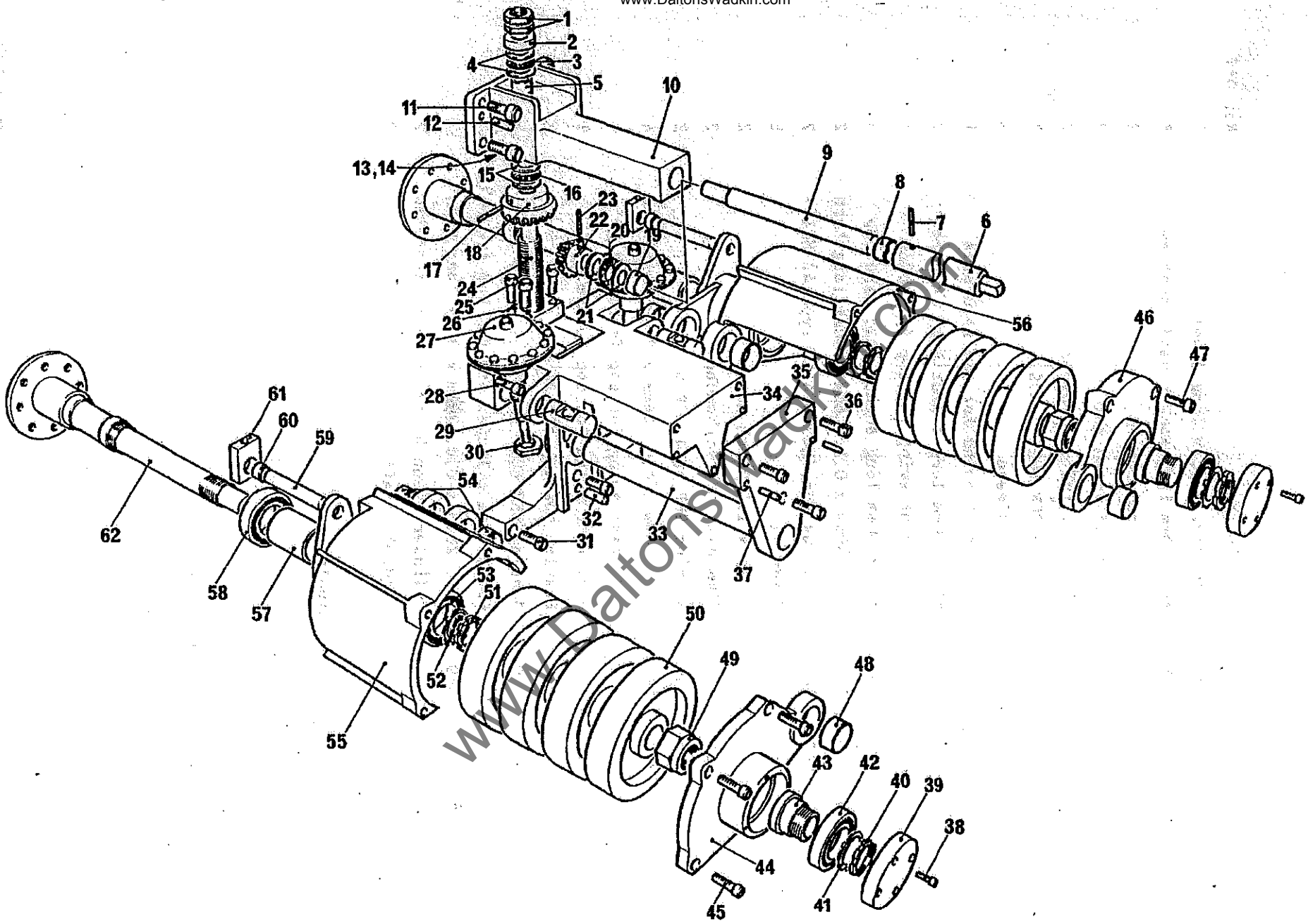

ENCLOSED FEEDWORKS (TOP)

ENCLOSED FEEDWORKS (BOTTOM)

Ref.No.	Part No.	Description	No. Off
1	K05 27 105	M16mm hexagon nut	1
2	K05 25 187	M8 x 20mm long socket head capscrew	4
3	FB 14018	Bottom feedroll pivot pin support	1
4	K05 31 592	I.D. 40mm x O.D. 46mm x 30mm long bush	2
5	FB 14014	L.H. front swing for bottom feedrolls	1
6	FB 14015	R.H. front swing for bottom feedrolls	1
7	FB 14057	Collar	1
8	K30 05 650	M16mm x 220mm long hexagon head bolt	1
9	K05 27 212	M55 x 1.5mm notch nut	2
10	K05 27 261	55mm dia. tab lockwasher	2
11	K05 27 111	M12 thin nut	2
12	K05 25 545	M12mm x 35mm long hexagon head screw	2
13	K06 01 130	Bearing SKF 6011 2 R.S.	2
14	FB 14036	Bearing sleeve	2
15	FB 14056	Bearing end cap	2
16	K05 27 162	Philidas nut (M42 x 4.5mm) type 42 MCl	2
17	K05 26 166	M6mm x 20mm long socket head capscrew	8
18		Feedroll - straight flute - 250mm. dia.	8
19	K05 27 212	M55 x 1.5 notch nut	2
20	K05 27 261	55mm dia. tab lockwasher	2
21	K06 01 130	Bearing SKF 6011 2 R.S.	2
* 21 ^a		"SEEGER" spring ring SB 90mm. bore	4
22	K05 31 580	I.D. 40 x O.D. 46 x 25mm long bush	2
23	FB 14013	Rear swing for bottom feedrolls	1
24	FB 14013	Rear swing for bottom feedrolls	1
25	K05 31 580	I.D. 40mm x O.D. 46mm x 25mm long bush	2
26	FB 14075	Pivot pin for bottom feedworks swing	1
27	FB 2878	Bearing spacing sleeve	2
28	K06 01 130	Bearing SKF 6011 2 R.S.	2
29	FB 14021	Feedroll shaft	2
30	K05 27 111	M12 Thin nut	2
31	K05 25 545	M12 x 35mm long hexagon head screw	2
32	K30 09 134	40mm dia. external circlip	4
33	K05 31 592	40mm i.d. x 46mm o.d. x 30mm long bronze oil retaining bushes	4
34	FB 14032	Eccentric shaft for rise and fall of bottom feedroll	2
35	FB 2875	Worm for eccentric shaft	2
36	K05 20 506	No. 3 Taper pin	2

* Not shown

ENCLOSED FEEDWORKS (BOTTOM).....CONTD.

Ref.No.	Part No.	Description	No.Off
37	-	-	
38	FB 14033	Worm driven shaft	1
39	K05 20 505	No.2. taper pin	1
40	FB 2880	Square drive extension	1

www.DaltonsWadkin.com

MAY, 1983

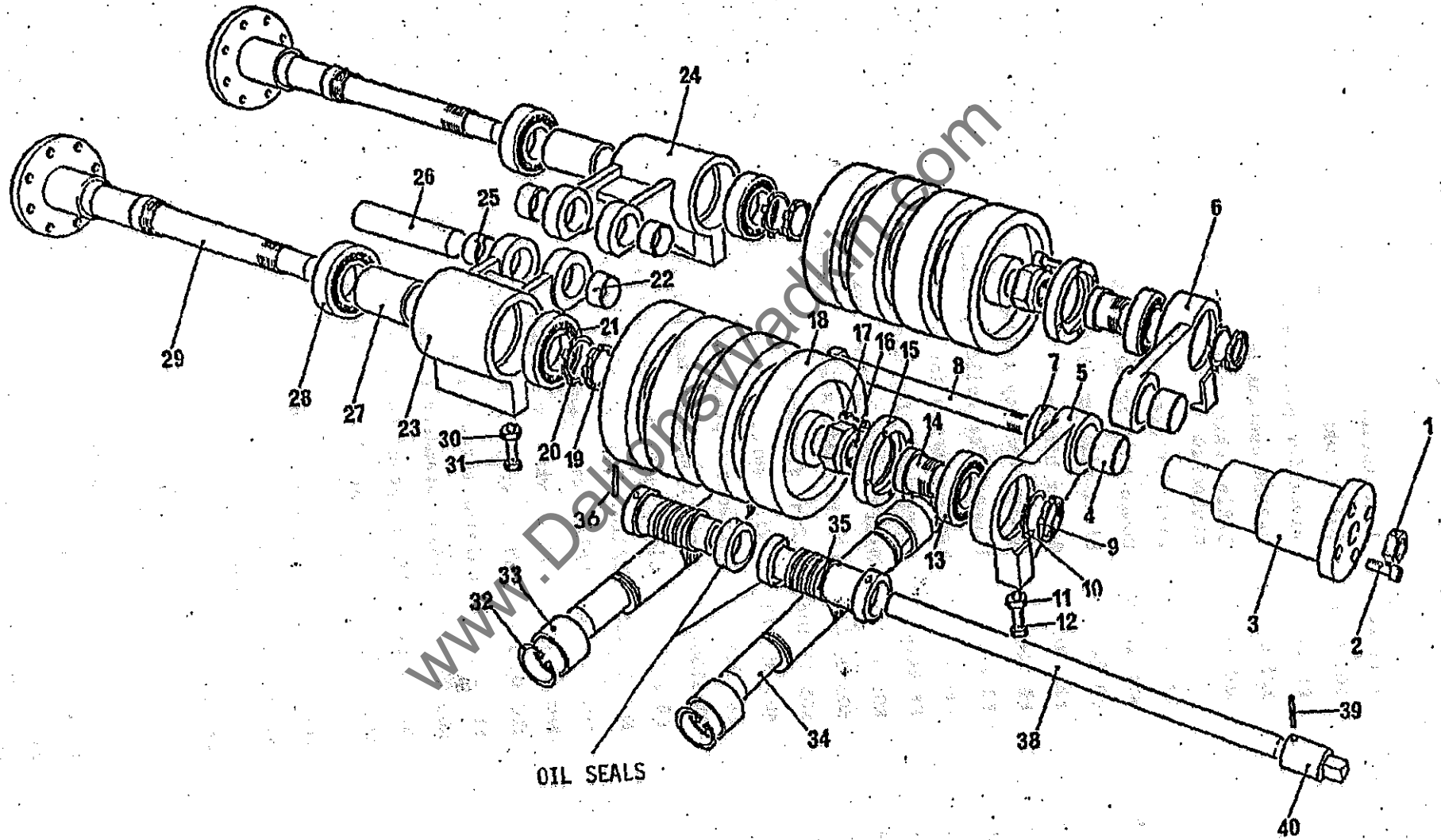

ENCLOSED FEEDWORKS (BOTTOM)

ROLLER PRESSURE OVER FIRST BOTTOM HORIZONTAL HEAD FOR MODELS 1, 2, 5, 6, 1U, 2U, 5U, 6U.

Ref.No.	Part No.	Description	No. Off
1	K05 01 171	3/8in. whit. x lin. socket head capscrew	8
2	FB 2425	Pivot for pressure roller	4
3	K06 01 249	FAFNIR bearing DN 211	4
4	K05 06 140	3/8in. whit. x 1/2in. hexagon socket grubscrew	2
5	FB 2447	Link for pressure rollers	2
6	K05 22 350	Compo bush SN 025 x 750	4
7	FB 2436	Pivot pin for roller	2
8	FB 2301	Roller bracket	1
9	FB 2440	Spring for top roller pressure	2
10	FB 2414	Plunger for roller pressure	2
11	FB 2415	Tension screw for pressure	2
12	FB 2416	Clamp plate for horizontal bar	1
13	K05 05 176	3/8in. whit. x lin. hexagon head capscrews	2
14	K05 21 450	1/2in. whit. x 15° adjustable hand levers	1
15	K05 11 106	1/2in. diameter washer	1
16	K05 08 472	1/2in. whit. x 1.3/4in. long stud	1
17	FB 1389	Horizontal pressure bar	1
18	FB 13307	Support bracket for horizontal bar	1
19	FB 2350	Clamp plate for horizontal bar	1
20	K05 21 450	1/2in. whit. x 15° adjustable hand lever	2
21	K05 11 106	1/2in. bore washer	2
22	K05 08 472	1/2in. whit. x 1.3/4in. long stud	2
23	K05 05 176	3/8in. whit. x lin. hexagon head screw	4
24	FB 2413	Raising screw for pressure	1
25	K05 20 103	3/4in. standard collar	1
26	K05 10 145	'Torrington' thrust race TRA 1220	1
27	K05 10 106	'Torrington' needle thrust bearing NTA 1220	1
28	K06 10 148	'Torrington' thrust race TRD 1220	1
29	K05 05 178	5/16in. whit. x 1.1/2in. hexagon head screw	2
30	FB 13302	Rise and fall bracket for pressure	1
31	K05 01 173	3/8in. whit. x 1.1/2in. socket head capscrew	1
32	FB 13427	Vertical pressure bar	1
33	FB 2417	Clamp plate for vertical bar	1
34	FB 2319	Lower support bracket for vertical bar	1
35	K05 01 171	3/8in. whit. x 1.1/2in. socket head capscrew	6
36	K05 20 485	Tension pin 4mm dia. x 32mm long	1
37	FB 13499	Wear strip for support bracket	1

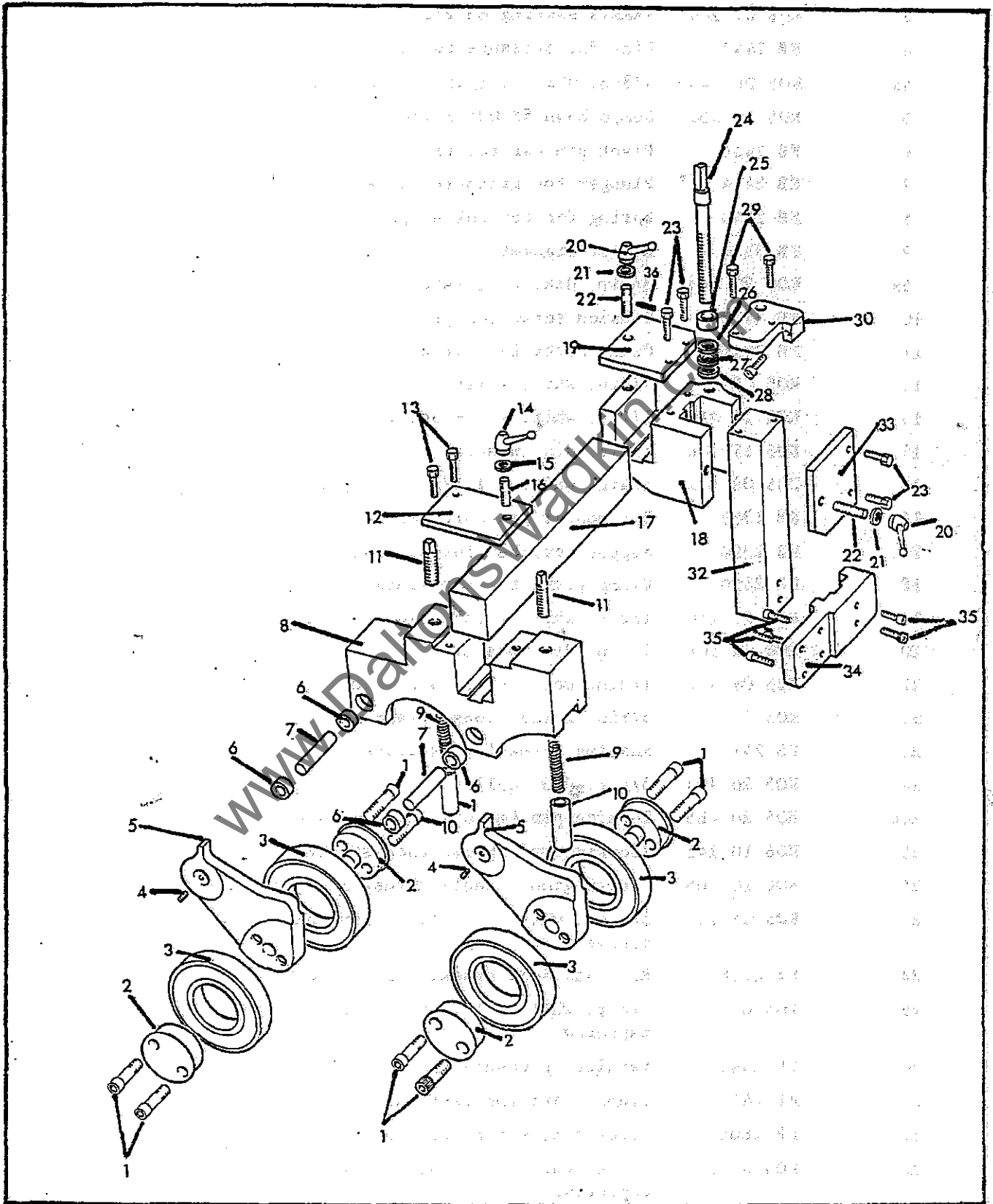

ROLLER PRESSURE OVER FIRST BOTTOM HEAD

WIDE ROLLER PRESSURE AFTER FIRST BOTTOM HORIZONTAL HEAD FOR MODELS 1, 2, 1U, 2U.

Ref. No.	Part No.	Description	No. Off
1	K05 01 171	3/8in. whit. x lin. socket head capscrew	4
2	FB 2425	Pivot for pressure roller	2
3	K06 01 249	FAFNIR bearing on 211	2
4	FB 2447	Link for pressure rollers	1
4a	K05 06 140	3/8in. whit. x 1/2in. socket head grub screw	1
5	K05 22 350	Compo bush SN 025 x 750	2
6	FB 2436	Pivot pin for roller link	1
7	FB 2414	Plunger for pressure roller	1
8	FB 2440	Spring for top roller pressure	1
9	FB 2330	Roller bracket	1
9a	K05 20 643	3/8in. dia. x 2.3/4in. dowel	1
10	FB 2415	Tension screw for pressure	1
11	FB 2416	Clamp plate for horizontal bar	1
12	K05 05 176	3/8in. whit. x lin. hexagon head screw	2
13	K05 21 450	1/2in. whit. x 15° adjustable handlever	1
14	K05 11 106	1/2in. dia. washer	1
15	K05 08 472	1/2in. whit. x 1.1/2in. long stud	1
16	FB 1389	Horizontal pressure bar	1
17	FB 2390	Support bracket for horizontal bar	1
18	FB 2350	Clamp plate for horizontal bar	1
19	K05 21 450	1/2in. whit. x 15° Adjustable hand lever	2
20	K05 11 106	1/2in. dia. washer	2
21	K05 08 472	1/2in. whit. x 1.3/4in. long stud	2
22	K05 05 176	3/8in. x lin. long hexagon head screw	4
23	FB 2413	Raising screw for pressure	1
24	K05 20 103	3/4in. dia. collar	1
24a	K05 20 485	Tension pin 4mm dia. x 32mm long	1
25	K06 10 145	'Torrington' Thrust race TRA 1220	1
26	K06 10 106	'Torrington' Needle thrust bearing NTA 1220	1
27	K05 05 154	5/16in. whit. x 1.1/2in. long hexagon head screws	2
28	FB 2318	Rise and fall bracket for pressure	1
29	K05 01 173	3/8in. whit. x 1.1/2in. long socket head capscrew	1
30	FB 13427	Vertical pressure bar	1
31	FB 2417	Clamp plate for vertical bar	1
32	FB 1606	Lower steady for vertical bar	1
33	K05 01 172	3/8in. whit. x 1.1/4in. long socket head capscrews	5
34	K05 20 626	5/16in. dia. x 1.1/4in. long plain dowels	2

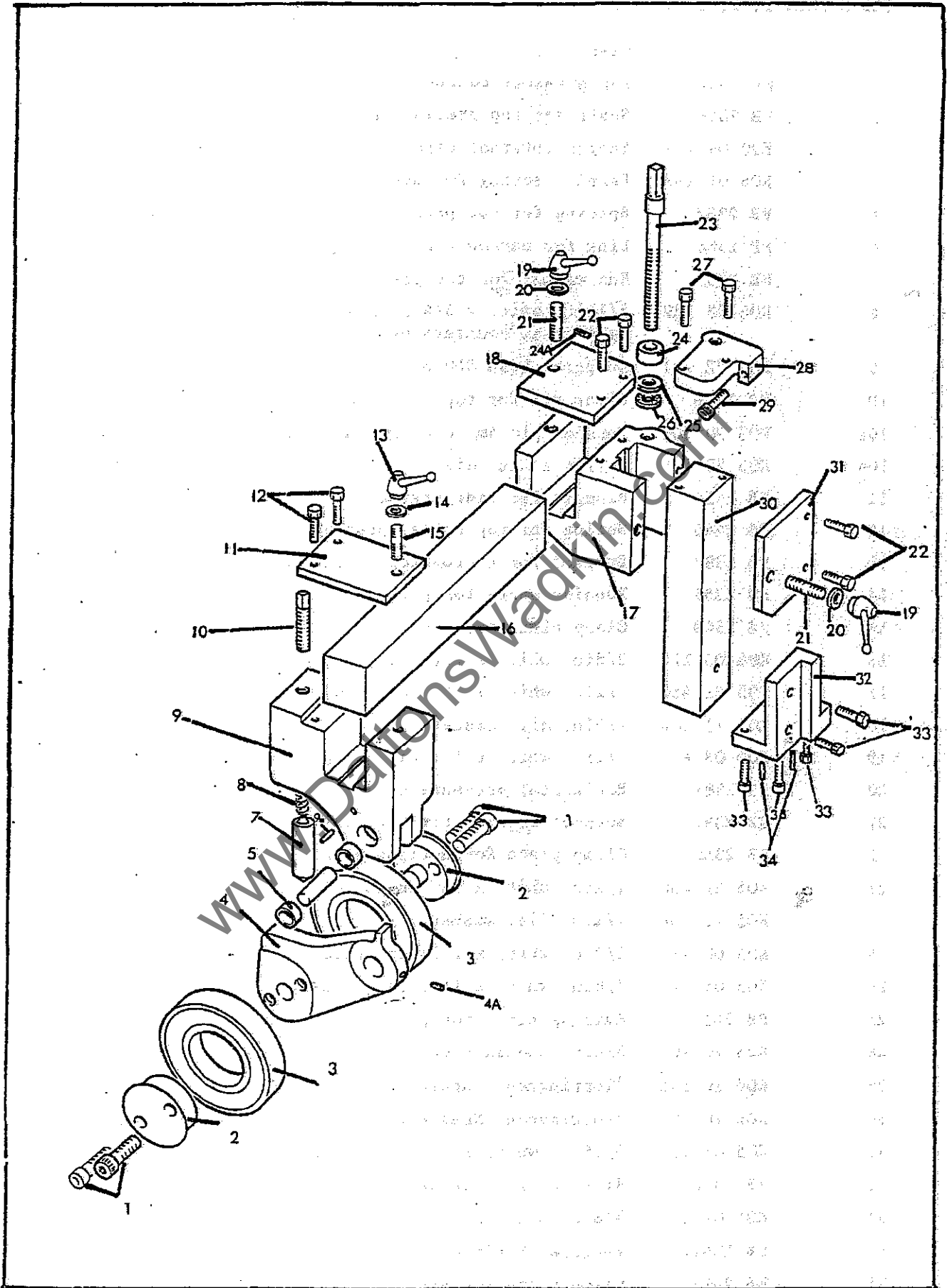

WIDE ROLLER PRESSURE AFTER FIRST BOTTOM HEAD

TOP ROLLER PRESSURE BETWEEN 12in. STAGGER SIDE HEADS FOR NARROW STOCK
FOR MODELS 1, 2, 1U and 2U

Ref.No.	Part No.	Description	No. Off
1	FB 2384	Top pressure roller	1
2	FB 2356	Shaft for top pressure roller	1
3	K30 09 272	Seeger internal circlip bore size 40	2
4	K06 01 197	Fafnir bearing 203 NPP	2
5	FB 2357	Spacing for top pressure roller	1
6	FB 2388	Link for narrow top roller pressure	1
7	FB 2358	End washer for top pressure roller	1
8	K05 03 332	5/16in. whit. x 3/4in. long wedglok socket head screw countersunk	1
9	K05 22 231	Ludbrook bush SNO 30 x 1/2in. long	2
10	FB 2369	Pivot pin for top pressure roller	1
10a	K05 20 500	Tension pin 4mm dia. x 28mm long	1
10b	K05 20 101	Collar 1/2in. dia.	1
11	FB 2414	Plunger for side pressure	1
12	FB 2440	Spring for top roller pressure	1
13	FB 2387	Bracket for narrow top roller pressure	1
14	FB 2258	Tension screw for pressure	1
15	FB 2349	Clamp plate for pressure	1
16	K05 05 176	3/8in. whit. x 1in. long hexagon head screw	2
17	K05 21 450	1/2in. whit. x 15° adjustable hand lever	1
18	K05 11 106	1/2in. dia. washer	1
19	K05 08 472	1/2in. whit. x 1.3/4in. long stud	1
20	FB 1389	Horizontal pressure bar	1
21	FB 2390	Support bracket for horizontal bar	1
22	FB 2350	Clamp plate for horizontal bar	1
23	K05 21 450	1/2in. whit. x 15° adjustable hand lever	2
24	K05 11 106	1/2in. dia. washer	2
25	K05 08 472	1/2in. whit. x 1.3/4in. studs	2
26	K05 05 176	3/8in. whit. x 1in. long hexagon head screw	4
27	FB 2413	Raising screw for pressure	1
28	K05 20 103	3/4in. standard collar	1
29	K06 10 145	'Torrington' Thrust race TRA 1220	1
30	K06 10 106	'Torrington' Needle thrust bearing WTA 1220	1
31	K05 05 154	5/16in. whit. x 1.1/2in. hexagon head screw	2
32	FB 2318	Rise and fall bracket for pressure	1
33	K05 01 173	3/8in. whit. x 1.1/2in. hexagon hole capscrew	1
34	FB 13427	Vertical bar for pressure	1
35	FB 2417	Clamp plate for vertical bar	1
36	FB 13425	Lower steady for pressure bar	1
37	K05 01 172	3/8in. whit. x 1.1/4in. hexagon hole capscrew	3

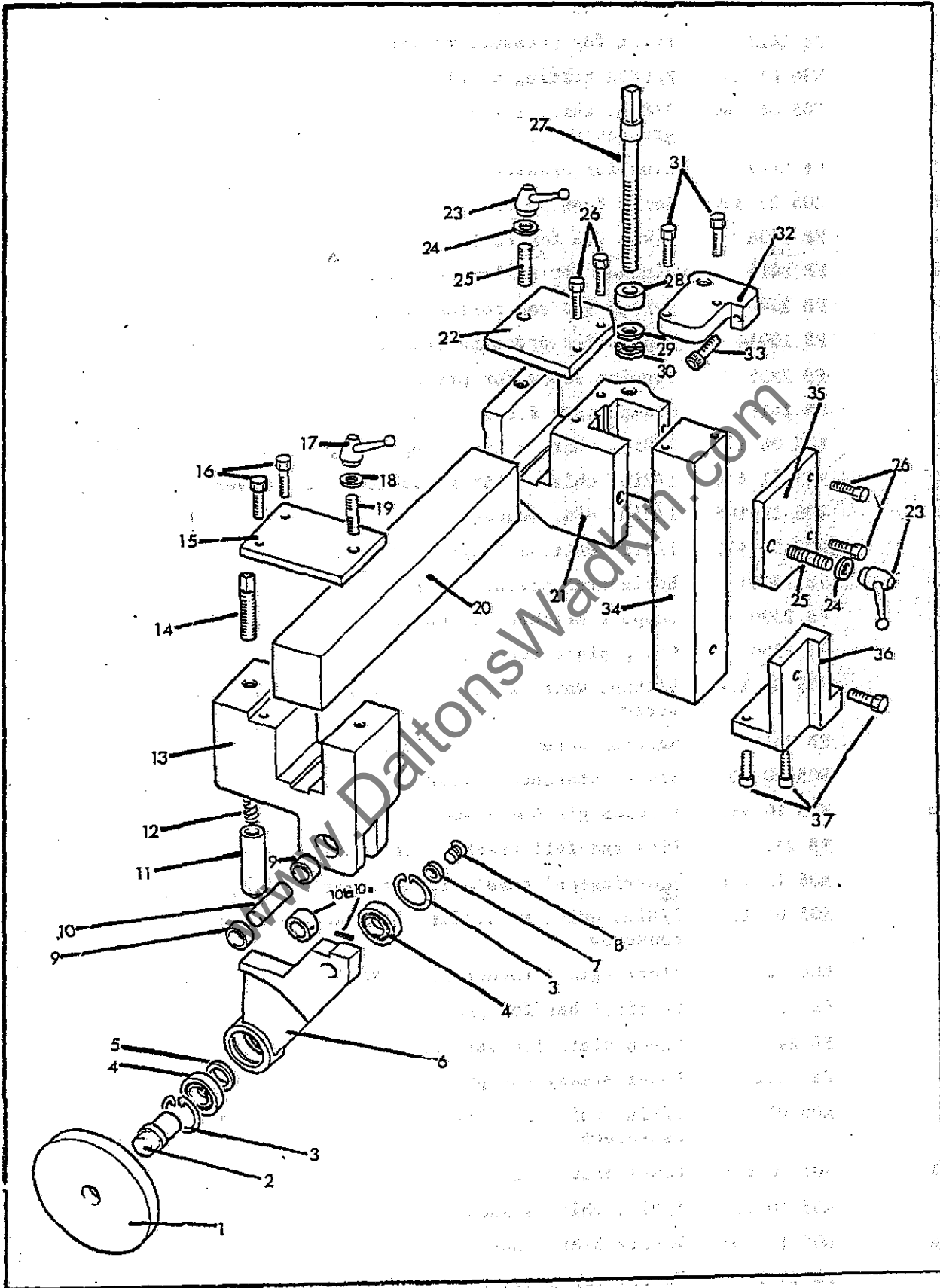

TOP ROLLER PRESSURE BETWEEN 12in. STAGGER SIDE HEADS
FOR NARROW STOCK

TOP ROLLER PRESSURE BETWEEN SIDE HEADS FOR MODELS 1, 2, 1U and 2U

Ref.No.	Part No.	Description	No. Off
1	K05 01 171	3/8in. whit. x 1in. long socket head capscrew	8
2	FB 2425	Pivot for pressure roller	4
3	K06 01 249	FAFNIR bearing on 211	4
4	K05 06 140	3/8in. whit. x 1/2in. long hexagon socket grubscrew	2
5	FB 2447	Link for pressure roller	2
6	K05 22 350	Compo bush SN 025 x 750 long	4
7	FB 2436	Pivot pin for roller	2
8	FB 2414	Plunger for roller pressure	2
9	FB 2440	Spring for top roller pressure	2
10	FB 13014	Top roller pressure bracket	1
11	FB 2258	Tension screw for pressure	2
12	FB 2416	Clamp plate for horizontal bar	1
13	K05 05 176	3/8in. whit. x 1in. long hexagon head screw	6
14	K05 21 450	1/2in. whit. x 15° Adjustable hand lever	3
15	K05 11 106	1/2in. dia. washer	3
16	K05 08 472	1/2in. whit. x 1.3/4in. long stud	3
17	FB 13401	Horizontal pressure bar	1
18	FB 2390	Support bracket for horizontal bar	1
19	FB 2350	Clamp plate for horizontal bar	1
20	K05 05 154	5/16in. whit. x 1.1/2in. long hexagon head screw	2
21	FB 2413	Raising screw for pressure	1
22	K05 20 103	3/4in. standard collar	1
22a	K05 20 486	Tension pin 4mm x 40mm	1
23	FB 2318	Rise and fall bracket for pressure	1
24	K06 10 106	'Torrington' needle thrust bearing NTA 1220	1
25	K05 01 173	3/8in. whit. x 1.1/2in. long socket head capscrew	1
26	K06 10 145	'Torrington' thrust race TRA 1220	2
27	FB 13427	Vertical bar for pressure	1
28	FB 2417	Clamp plate for vertical bar	1
29	FB 13425	Lower steady for pressure bar	1
30	K05 01 172	3/8in. whit. x 1.1/4in. long socket head capscrews	3
30a	K05 20 626	Dowel 5/16in. dia. x 1.1/4in. long	2
31	K05 10 325	5/8in. whit. standard hexagon nut left hand	2
31a	K05 11 107	Washer 5/8in. bore	2
32	FB 2451	Narrow top pressure roll finished size 4in. dia. x 11/16in. wide	2
33	K05 22 106	Glacier bush 12 DU08	2
34	FB 2426	Pivot pin for narrow roller (5/8in. whit. L.H.)	2

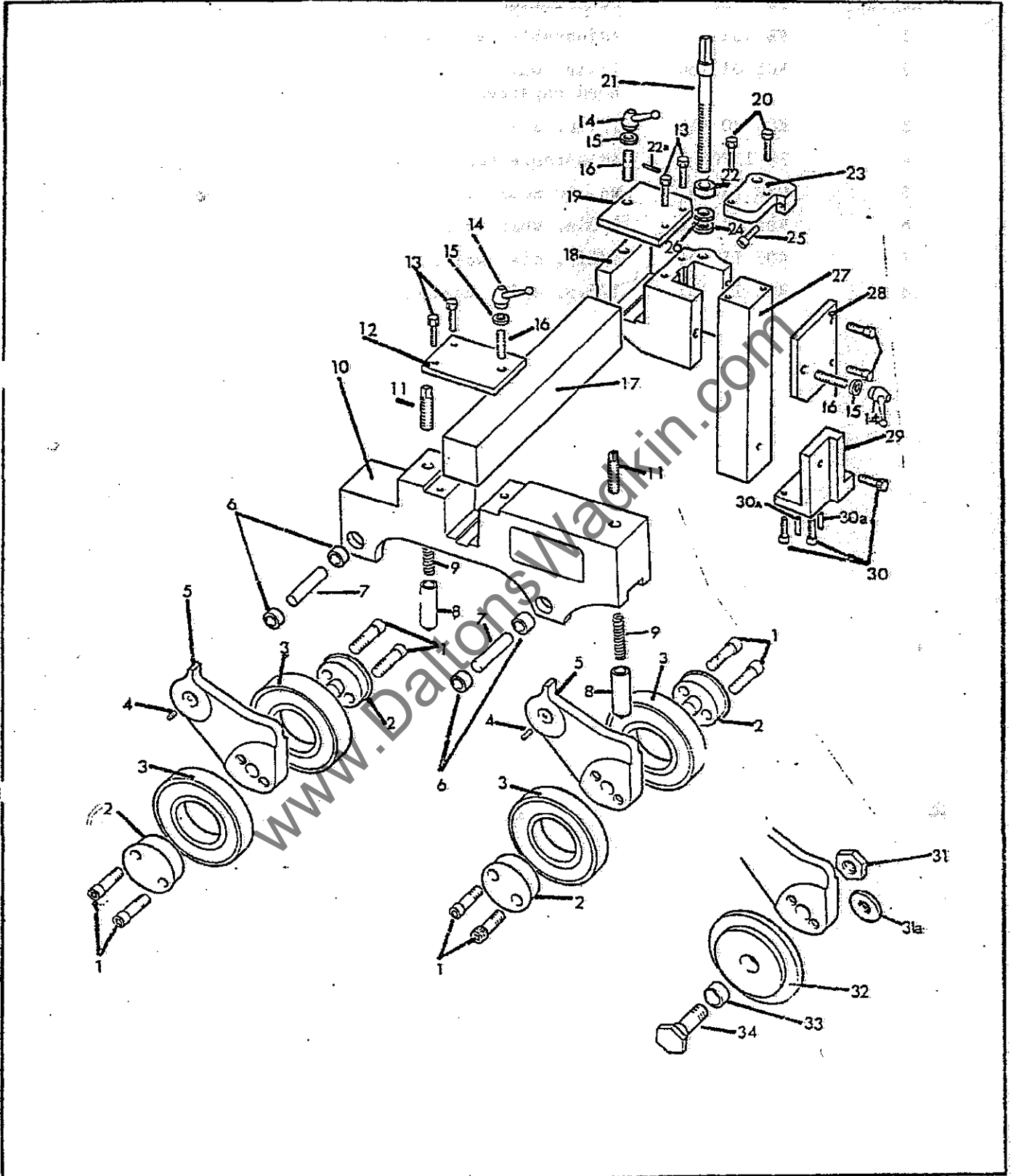

TOP ROLLER PRESSURE BETWEEN SIDE HEADS FOR MODELS 1, 2, 1U and 2U

SIDE PAD PRESSURE AFTER SIDE HEADS

Ref.No.	Part No.	Description	No. Off
1	FB 13110	Adjustable fence slide block	1
2	K05 01 130	1/4in. whit. x 1.3/4in. long socket head capscrew	2
3	K05 20 618	1/4in. dia. x 2in. long dowel	2
4	FB 13008	Adjustable fence slide	1
5	K30 73 161	No. 10 wood screw 1.1/4in. long	2
6	K05 08 471	1/2in. whit. x 1.1/2in. long stud	1
7	K05 11 106	1/2in. dia. washer	1
8	K05 10 107	1/2in. whit. hexagon nut	1

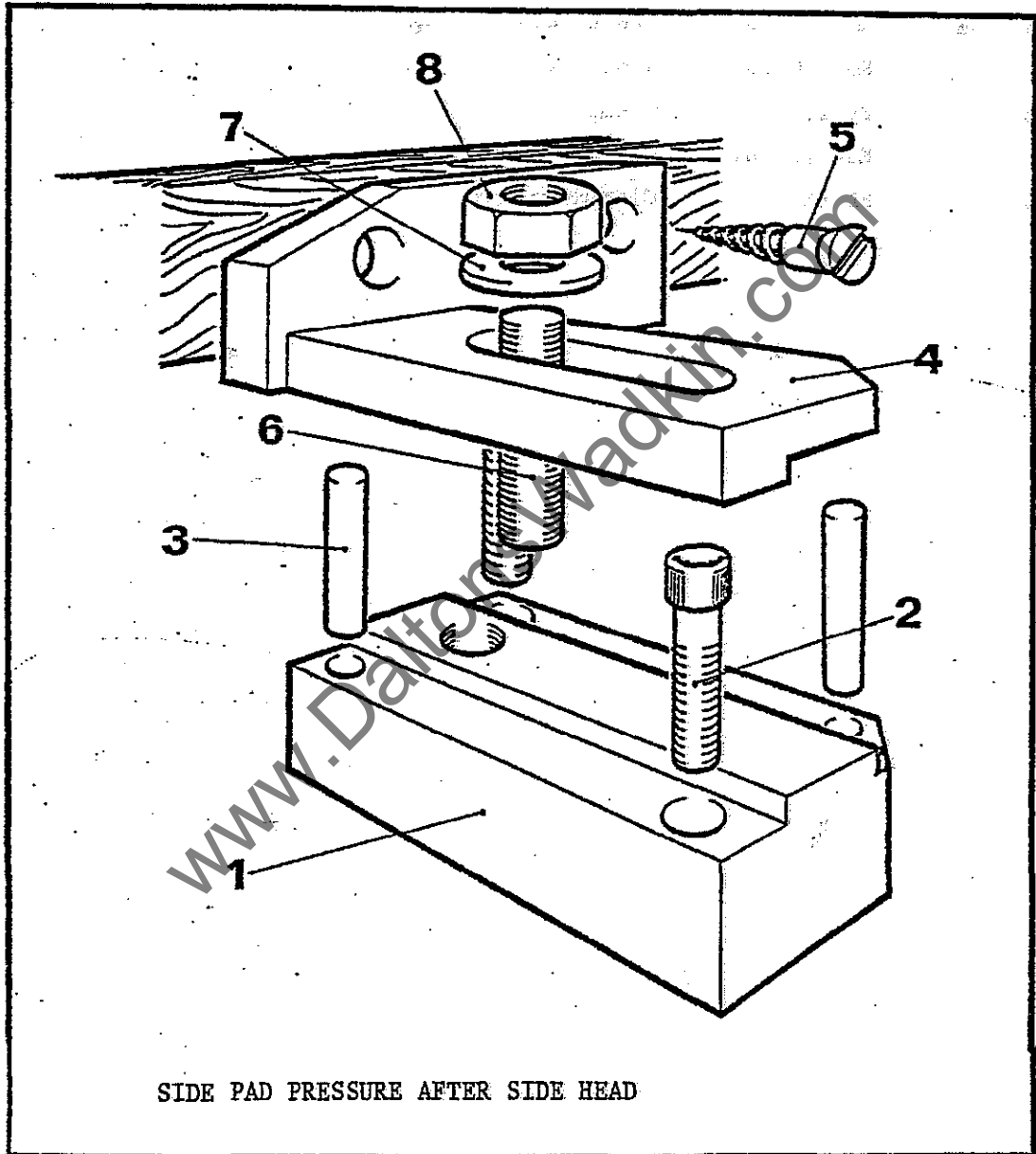

SIDE PAD PRESSURE AFTER SIDE HEAD

SIDE PAD PRESSURE AFTER SECOND TOP HEAD

Ref. No.	Part No.	Description	No. Off
1	FB 603/A	Side pressure bracket	1
2	K05 11 104	3/8in. dia. washer	2
3	K05 05 178	3/8in. whit. x 1.1/2in. long hexagon head screw	2
4	K05 20 616	1/4in. dia. x 1.1/2in. long dowel	2
5	K05 08 457	3/8in. whit. x 2.1/4in. long stud	1
6	K05 11 104	3/8in. dia. washer	1
7	K05 10 105	3/8in. whit. hexagon nut	1
8	FB 230	Clamping rod	1
9	K30 73 161	No. 10 Wood screw x 1.1/4in. long	3
10	FD 681	Clamping plate	1

www.DaltonsWadkin.com

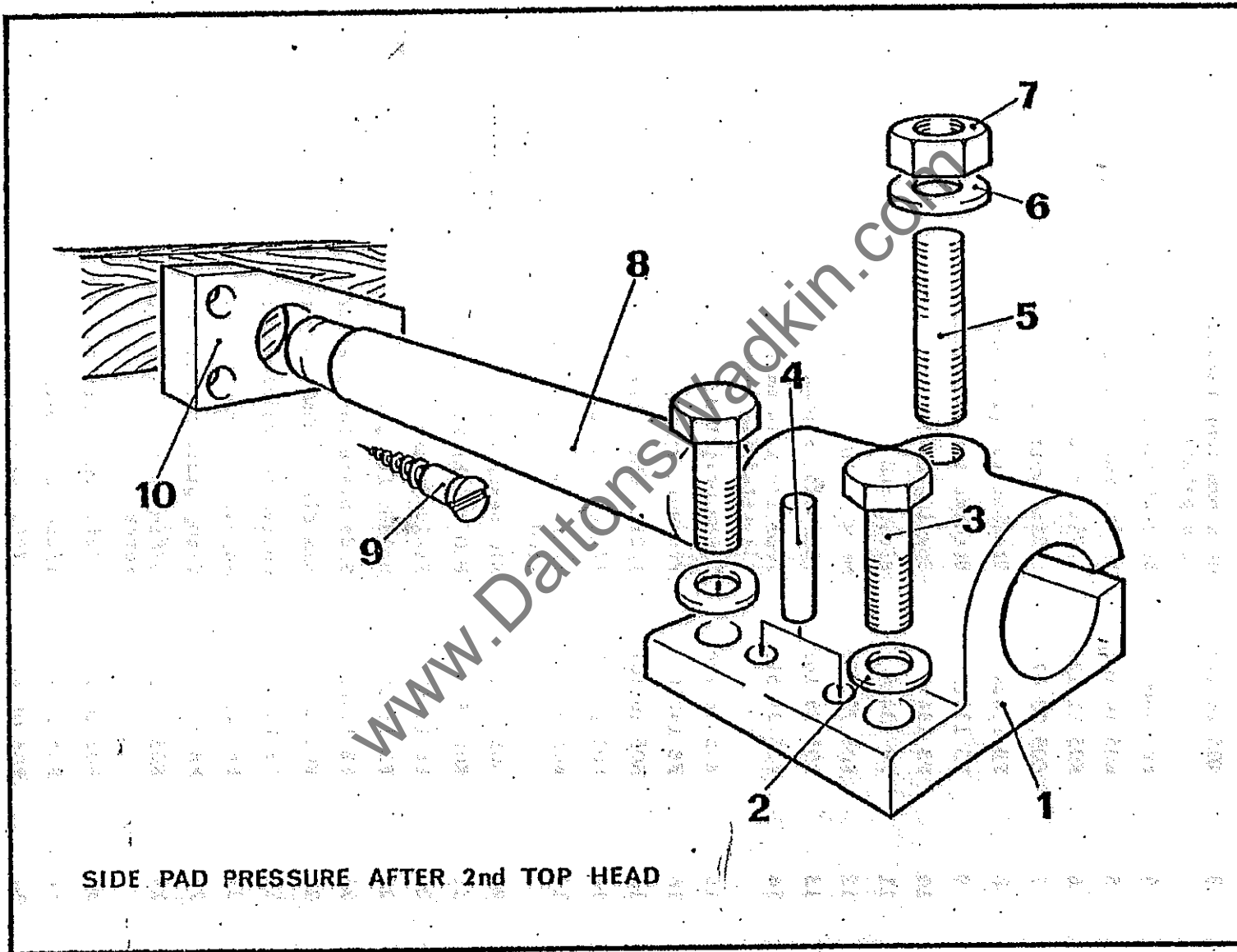

SIDE PAD PRESSURE AFTER 2nd TOP HEAD

WIDE TOP PAD PRESSURE OPPOSITE NEAR SIDE HEAD

Ref.No.	Part No.	Description	No. Off
1	K05 31 526	12mm i/d x 16mm o/d x 12mm long bronze oil retaining bushes	4
2	K05 29 174	12mm dia. x 45mm long plain dowels	2
3	K05 26 112	M6 x 6mm long hexagon socket screws (cup point)	2
4	FB 13460	Bracket for pressure shoe plate	1
5	K05 10 107	1/2in. whit. hexagon nut	1
6	K05 11 126	1/2in. M. S. Black washer	1
7	K05 08 477	1/2in. whit. x 3in. long screwed stud	1
8	FB 13424	Bracket for pressure	1
9	FB 13423	Bracket for pad pressure	1
10	FB 13447	Spacing collar	4
11	FB 13446	Pivot arm	2
12	K05 25 187	M8 x 20 long hexagon socket cap screw	4
13	K05 29 163	10mm dia. x 60mm long plain dowel	2
14	K05 31 513	10mm i/d x 14 mm o/d x 10mm long bronze oil retaining bushes	4
15	K05 28 104	M10mm bright M. S. washer	1
16	FB 14214	Pressure spring	1
17	K05 10 107	1/2in. whit. hexagon nut	1
18	K05 11 126	1/2in. M.S. black washer	1
19	K05 08 476	1/2in. whit. x 2.3/4in. long screwed stud	1
20	K05 27 110	M10 hexagon thin nut	2
21	K05 28 104	M10 bright M.S. washer	1
22	FB 13465	Preload stud	1
23	FB 13455	Holder for pressure	1
24	FB 13462	Side plate for pressure	2
25	K05 20 500	4mm dia. x 28mm long tension pin	1
26	FB 2355	Collar for raising screw	1
27	FB 2412	Adjusting screw for pad pressures	1
28	FB 2416	Clamp plate for horizontal bar	1
29	K05 05 176	3/8in. whit. x 1in. long hexagon head screw	2
30	K05 10 107	1/2in. whit. hexagon nut	1
31	K05 11 106	1/2in. dia. washer	1
32	K05 08 472	1/2in. whit. x 1.3/4in. long stud	1
33	FB 1389	Horizontal pressure bar	1
34	FB 2390	Support bracket for horizontal bar	1
35	K05 08 472	1/2in. whit. x 1.3/4in. long stud	1

WIDE TOP PAD PRESSURE OPPOSITE NEAR SIDE HEAD (cont.)

Ref.No.	Part No.	Description	No. Off
36	K05 11 106	1/2in. dia. washer	1
37	K05 21 450	1/2in. whit. x 15° adjustable handlever	1
38	K05 05 176	3/8in. whit. x 1in. long hexagon head screws	2
39	FB 2413	Raising screw for pressure	1
40	K05 20 500	4mm dia. x 28mm long tension pin	1
41	K05 20 103	3/4in. dia. collar	1
42	K06 10 106	Torrington needle thrust bearing NTA 1220	1
43	K06 10 145	Torrington thrust race TRA 1220	2
44	K05 05 154	5/16in. whit. x 1.1/2in. long hexagon head screws	2
45	K05 01 173	3/8in. whit. x 1.1/2in. long socket head capscrew	1
46	FB 1366	Vertical pressure bar	1
47	FB 2417	Clamp plate for vertical bar	1
48	K05 05 176	3/8in. whit. x 1in. hexagon head screws	2
49	K05 08 472	1/2in. whit. x 1.3/4in. long stud	1
50	K05 11 106	1/2in. dia. washer	1
51	K05 21 450	1/2in. whit. x 15° adjustable handlever	1
52	FB 13425	Lower steady for pressure bar	1
53	K05 01 172	3/8in. whit. x 1.1/4in. long socket head capscrews	3
54	FB 2350	Clamp plate for horizontal bar	1
55	FB 2318	Rise and fall bracket for pressure	1

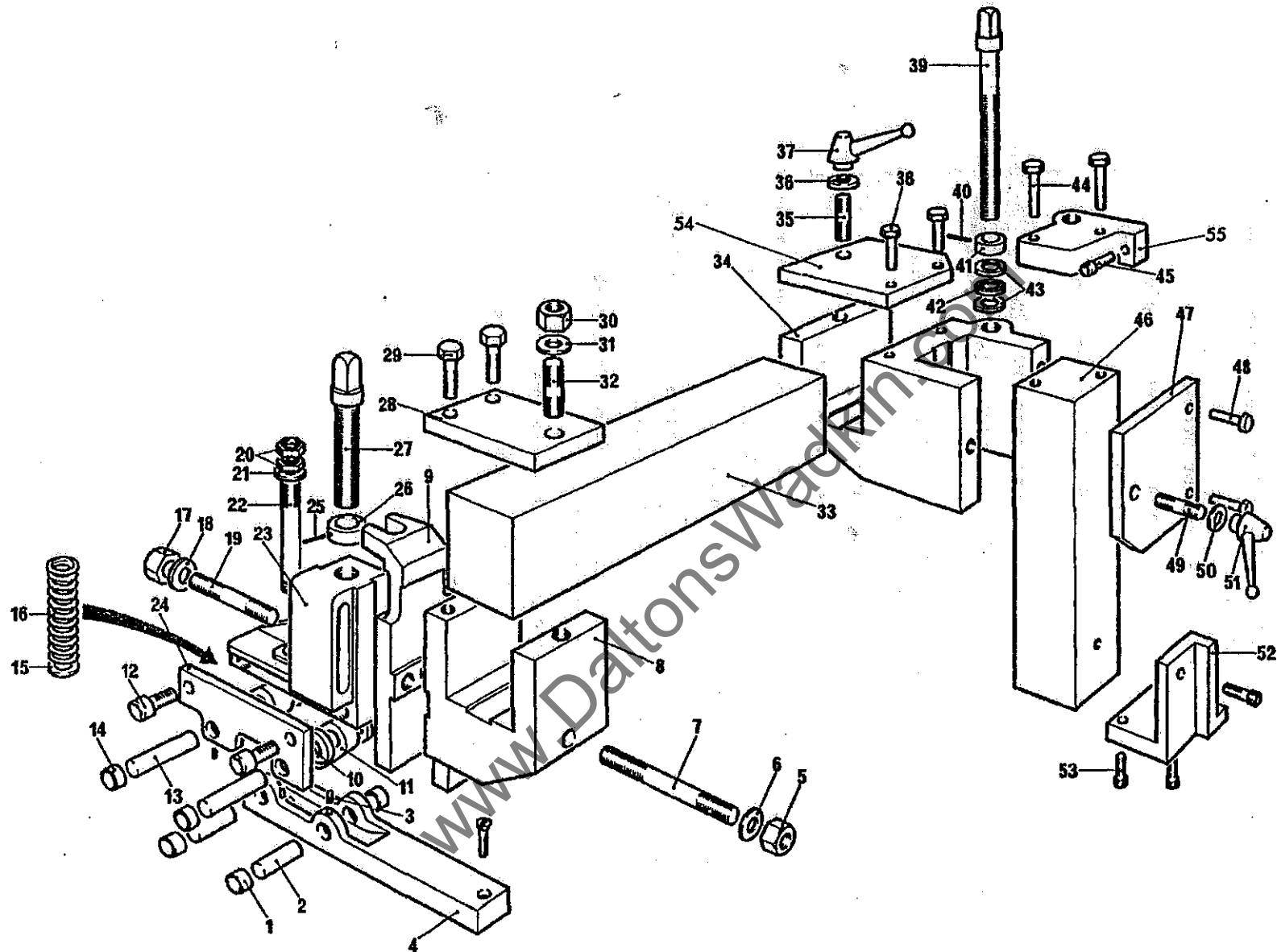

WIDE TOP PAD PRESSURE OPPOSITE NEAR SIDE HEAD

WIDE TOP PAD PRESSURE BEFORE SECOND TOP HEAD models 5, 6, 1U, 2U, 5U and 6U.

Ref.No.	Part No.	Description	No. Off
1	K05 10 105	3/8in. whit. hexagon nut	4
2	K05 01 169	3/8in. whit. x 3/4in. hexagon hole capscrew	4
3	FB 13416	Side plate for pressure	2
4	FB 13414	Pin for top pad pressure	2
5	FB 13413	Rubber bush for top pad pressure	2
6	FB 13422	Bracket for pressure shoe	1
7	K05 10 107	1/2in. whit. standard nut	2
8	K05 11 126	1/2in. diameter washer	2
9	FB 13420	Holder for pressure	1
10	K05 08 483	1/2in. whit. x 4.1/2in. stud	1
11	K06 08 477	1/2in. whit. x 3in. stud	1
12	FB 2412	Screw for rise and fall	1
13	K06 10 145	'Torrington' thrust race TRA 1220	1
14	K06 10 106	'Torrington' needle thrust bearing NTA 1220	1
15	K05 20 103	3/4in. standard collar	1
15a	K05 20 486	Tension pin 4mm x 40mm	1
16	FB 13423	Bracket for pad pressure	1
17	FB 13424	Bracket for pressure	1
18	FB 1389	Horizontal pressure bar	1
19	FB 2416	Clamp plate for horizontal bar	1
20	K05 05 176	3/8in. whit. x 1in. long hexagon head screw	2
21	K05 21 450	1/2in. whit. x 15° adjustable handlever	1
22	K05 11 106	1/2in. dia. washer	1
23	K05 08 472	1/2in. whit. x 1.3/4in. long stud	1
24	FB 2390	Support bracket for horizontal bar	1
25	FB 2350	Clamp plate for horizontal bar	1
26	K05 21 450	1/2in. whit. x 15° adjustable handlever	2
27	K05 11 106	1/2in. dia. washer	2
28	K05 08 472	1/2in. whit. x 1.3/4in. stud	2
29	K05 05 176	3/8in. whit. x 1in. hex. head screws	4
30	FB 2413	Raising screw for roller pressure	1
31	K05 20 103	3/4in. dia. collar	1
31a	K05 20 486	Tension pin 4mm x 40mm	1
32	K06 10 145	'Torrington' thrust race TRA 1220	1
33	K06 10 106	'Torrington' Needle thrust bearing NTA 1220	1
34	K05 05 154	5/16in. whit. x 1.1/2in. hexagon head screws	2
35	FB 2318	Rise and fall bracket for pressures	1
36	K05 01 173	3/8in. whit. x 1.1/2in. long socket head capscrew	1
37	FB 1366	Vertical pressure bar before Universal head	1
38	FB 2417	Clamp plate for vertical bar	1

WIDE TOP PRESSURE BEFORE TOP HEAD (cont.)

Ref.No.	Part No.	Description	No. Off
39	FB 1368	Vertical pressure bar bracket	1
40	K05 05 175	3/8in. x 3/4in. long hexagon head screw (not shown)	4

www.DaltonsWadkin.com

Jan. '78

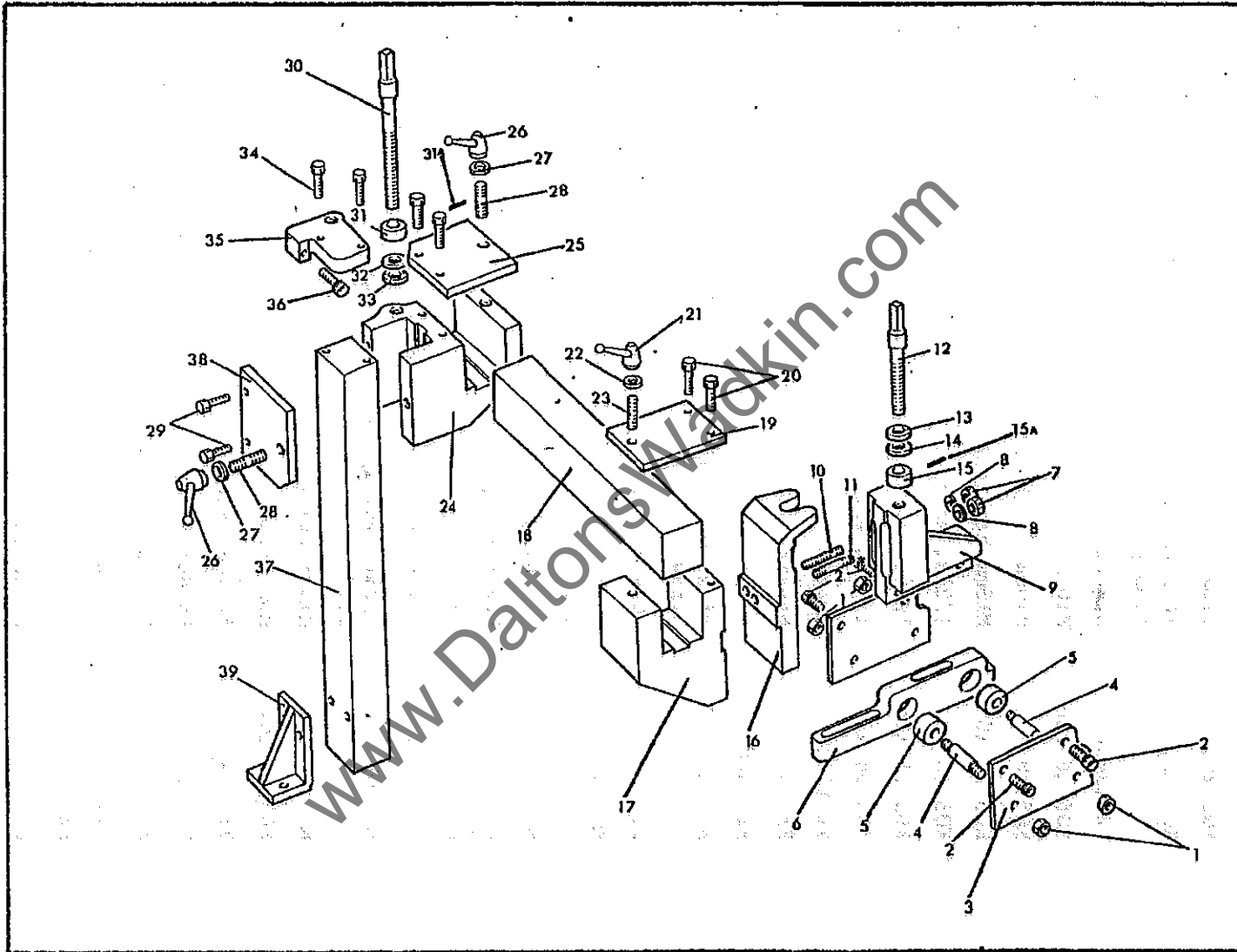

WIDE TOP PAD PRESSURE BEFORE SECOND TOP HEAD

WIDE TOP PAD PRESSURE AFTER TOP HEAD

Ref. No.	Part No.	Description	No. Off
1	FB 13457	Plate for pressure shoe	1
2	KO5 31 526	12mm i/d x 16mm o/d x 12mm long bronze oil retaining bushes	4
3	KO5 29 174	12mm dia. x 45mm long plain dowels	2
4	KO5 26 112	M6 x 6mm long hexagon socket screws (cup point)	2
5	FB 13456	Bracket for pressure shoe plate	1
6	KO5 26 266	M10 x 40 long screwed studs	2
7	KO5 28 104	M10mm bright M.S. washer	2
8	KO5 27 103	M10mm hexagon nut	2
9	KO5 10 107	1/2in. whit. hexagon nut	1
10	KO5 11 126	1/2in. M. S. black washer	1
11	KO5 08 477	1/2in. whit. x 3in. long screwed stud	1
12	FB 13423	Bracket for pad pressure	1
13	FB 13447	Spacing collar	4
14	FB 13446	Pivot arm	2
15	KO5 25 187	M8 x 20mm long hexagon socket cap screw	4
16	KO5 29 163	10mm dia. x 60mm long plain dowel	2
17	KO5 31 513	10mm i/d. x 14mm o/d x 10mm long bronze oil retaining bushes	4
18	KO5 28 104	m10 bright M.S. washer	1
19	FB 14214	Pressure spring	1
20	KO5 10 107	1/2in. whit. hexagon nut	1
21	KO5 11 126	1/2in. M. S. black washer	1
22	KO5 08 476	1/2in. whit. x 2.3/4in. long screwed stud	1
23	KO5 27 110	M10mm hexagon thin nut	2
24	KO5 28 104	M10 bright M. S. Washer	1
25	FB 13465	Preload stud	1
26	FB 13455	Holder for pressure	1
27	FB 13458	Side plate for pressure	2
28	KO5 20 500	4mm dia. x 28mm long tension pin	1
29	FB 2355	Collar for raising screw	1
30	FB 2412	Adjusting screw for pad pressures	1

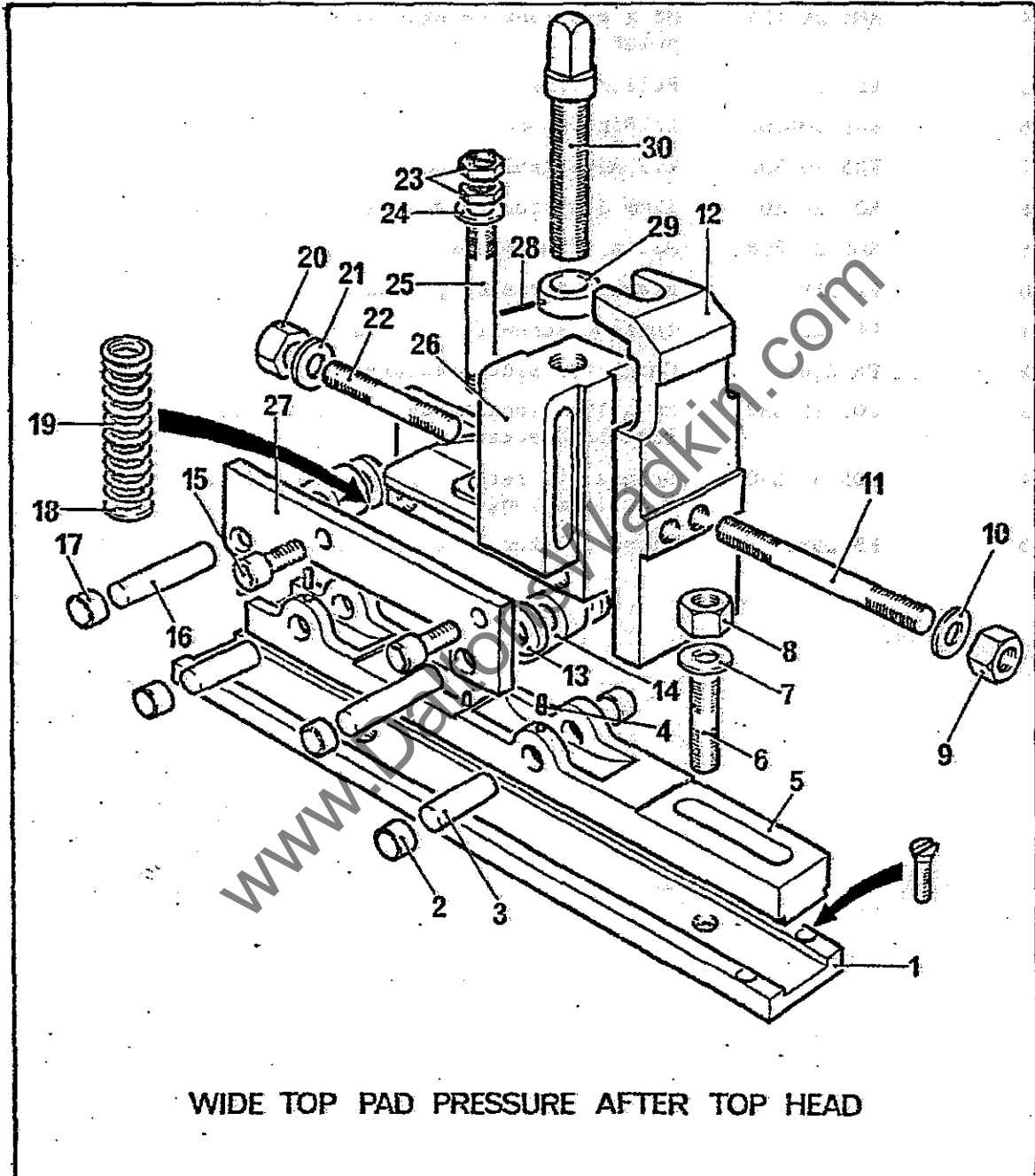

WIDE TOP PAD PRESSURE AFTER TOP HEAD

SIDE PRESSURE BEFORE FEEDROLLS

Ref.No.	Part No.	Description	No. Off
1	FB 2592	Plunger for side pressure	1
2	FB 2314	Spring for side pressure	1
3	K05 29 173	12mm dia. x 40mm long dowel	1
4	K05 26 124	M8 x 8mm long hexagon socket screw cup point	1
5	FB 2591	Roller link for side pressure	1
6	K09 50 101	5/16in. grease nipple P.108	1
7	K05 30 302	M12 Adjustable handlever	1
8	K05 28 105	12mm diameter bright washer	1
9	K05 26 298	M12 x 55mm long stud	1
10	FB 2590	Bracket for side pressure	1
11	FB 2258	Tension screw for pressure	1
12	FB 2443	Check for side pressure	1
13	K05 25 332	M8 x 16mm long hexagon socket counter-sunk head screw	2
14	K05 31 540	Bronze oil retaining bush 20 i.d. x 25 o.d. 15mm long	1
15	FB 2593	Pivot pin for side pressure	1

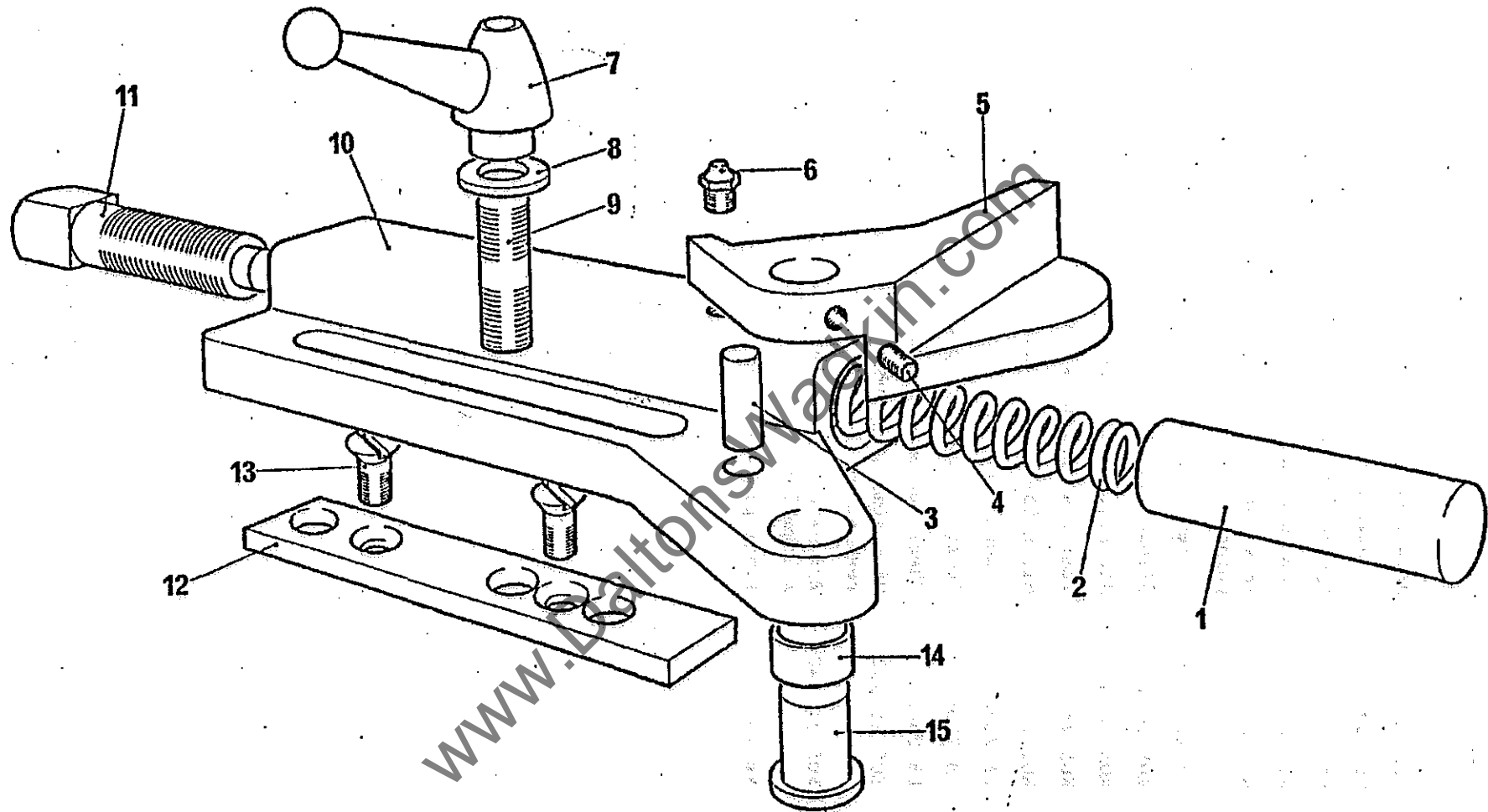

SIDE PRESSURE BEFORE FEED ROLLS

SIDE PRESSURE BEFORE FIRST BOTTOM HORIZONTAL HEAD

Ref.No.	Part No.	Description	No. Off
1	FB 2592	Plunger for side pressure	1
2	FB 2314	Spring for side pressure	1
3	K05 29 173	12mm dia. x 40mm long dowel	1
4	K05 26 124	M8 x 8mm long hexagon socket screw cup point	1
5	FB 2599	Roller link for side pressure	1
6	K09 50 101	5/16in. B.S.P. Grease Nipple P.108	1
7	K05 30 302	M12 Adjustable handlever	1
8	K05 28 105	12mm dia. bright washer	1
9	K05 26 298	M12 x 55mm long stud	1
10	FB 2590	Bracket for side pressure	1
11	FB 2258	Tension screw for pressure	1
12	FB 2443	Check for side pressure	1
13	K05 25 332	M8 x 16mm long hexagon socket countersunk head screw	2
14	K05 31 540	Bronze oil retaining bush 20 i.d. x 25 o.d. x 15mm long	1
15	FB 2593	Pivot pin for side pressure	1

Nov. '78

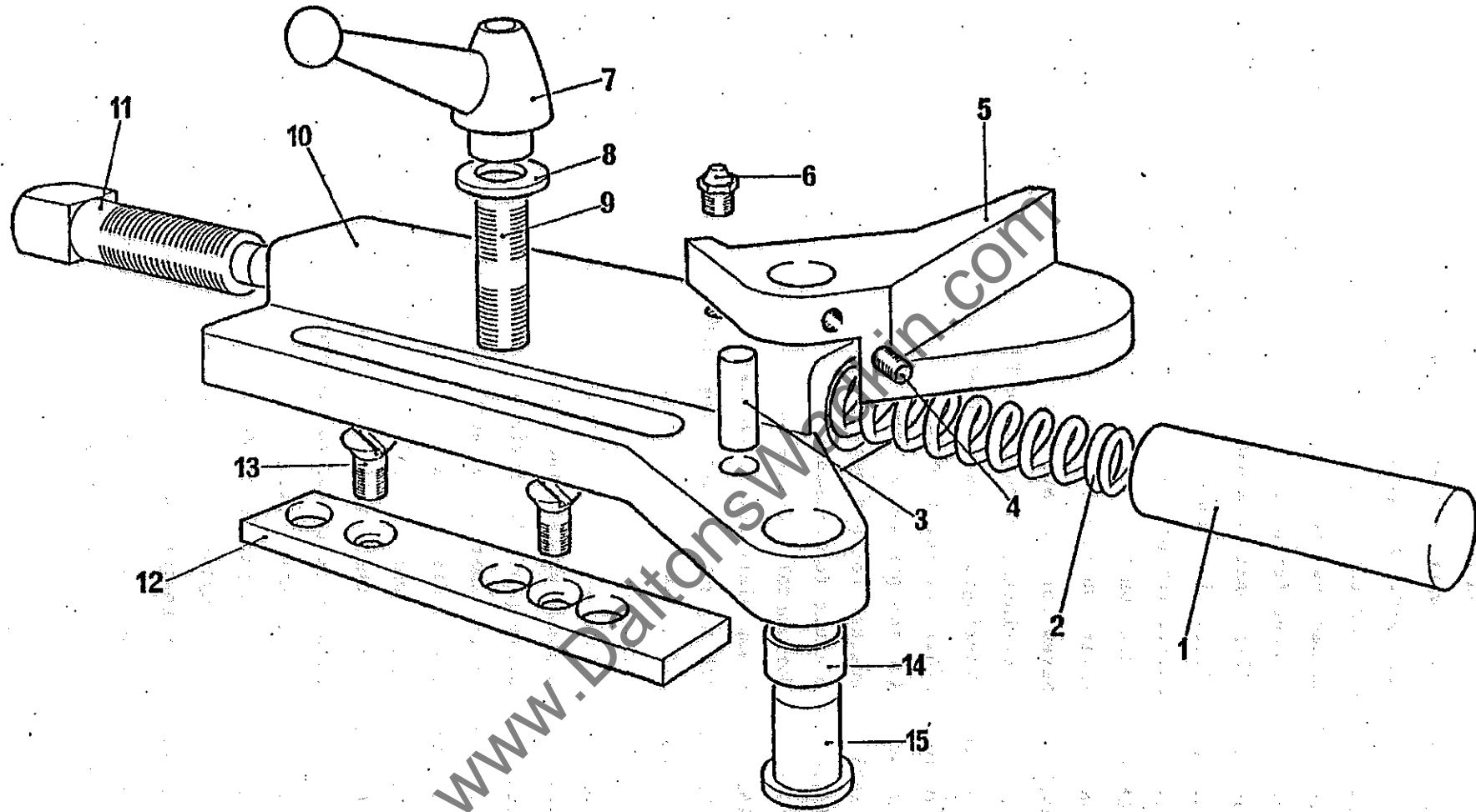

SIDE PRESSURE BEFORE FIRST BOTTOM HORIZONTAL HEAD

TOP PAD PRESSURE AFTER UNIVERSAL HEAD MODELS 1U and 5U

Ref.No.	Part No.	Description	No. Off
1	K05 10 105	3/8in. whit. hexagon nut	4
2	K05 01 169	3/8in. whit. x 3/4in. hexagon hole capscrew	4
3	FB 13416	Side plate for pressure	2
4	FB 13414	Pin for top pad pressure	2
5	FB 13413	Rubber bush for top pad pressure	2
6	FB 13422	Bracket for pressure shoe	1
7	K05 10 107	1/2in. whit. standard nut	2
8	K05 11 126	1/2in. dia. washer	2
9	FB 13420	Holder for pressure	1
10	K05 08 483	1/2in. whit. x 4 1/2in. stud	1
11	K06 08 477	1/2in. whit. x 3in. stud	1
12	FB 2412	Screw for rise and fall	1
13	K06 10 145	'Torrington' thrust race TRA 1220	1
14	K06 10 106	'Torrington' needle thrust bearing NTA 1220	1
15	K05 20 103	3/4in. standard collar	1
15a	K05 20 486	Tension pin 4mm x 40mm	1
16	FB 13423	Bracket for pad pressure	1
17	FB 13424	Bracket for pressure	1
18	FB 1389	Horizontal pressure bar	1
19	FB 2416	Clamp plate for horizontal bar	1
20	K05 05 176	3/8in. whit. x lin. long hexagon head screw	2
21	K05 21 450	1/2in. whit. x 15° adjustable handlever	1
22	K05 11 106	1/2in. dia. washer	1
23	K05 08 472	1/2in. whit. x 1.3/4in. long stud	1
24	FB 2391	Support bracket for horizontal bar	1
25	FB 2350	Clamp plate for horizontal bar	1
26	K05 21 450	1/2in. whit. x 15° adjustable handlever	2
27	K05 11 106	1/2in. dia. washer	2
28	K05 08 472	1/2in. whit. x 1.3/4in. stud	2
29	K05 05 176	3/8in. whit. x lin. hex. head screws	4
30	FB 2413	Raising screw for roller pressure	1
31	K05 20 103	3/4in. dia. collar	1
31a	K05 20 486	Tension pin 4mm x 40mm	1
32	K06 10 145	'Torrington' thrust race TRA 1220	1
33	K06 10 106	'Torrington' Needle thrust bearing NTA 1220	1
34	K05 05 154	5/16in. whit. x 1.1/2in. hexagon head screws	2
35	FB 2318	Rise and fall bracket for pressures	1

TOP PAD PRESSURE AFTER UNIVERSAL HEAD MODELS 1U and 5U (cont.)

Ref.No.	Part No.	Description	No. Off
36	K05 01 173	3/8in. whit. x 1.1/2in. long socket head capscrew	
37	FB 1353	Vertical pressure bar before Universal Head	1
38	FB 2417	Clamp plate for vertical bar	1
39	FB 1368	Vertical pressure bar bracket	1
40	K05 05 175	3/8in. x 3/4in. long hexagon head screw (not shown)	4
41	FB 13425	Lower steady for Pressure Bar (not shown)	1

www.DaltonsWadkin.com

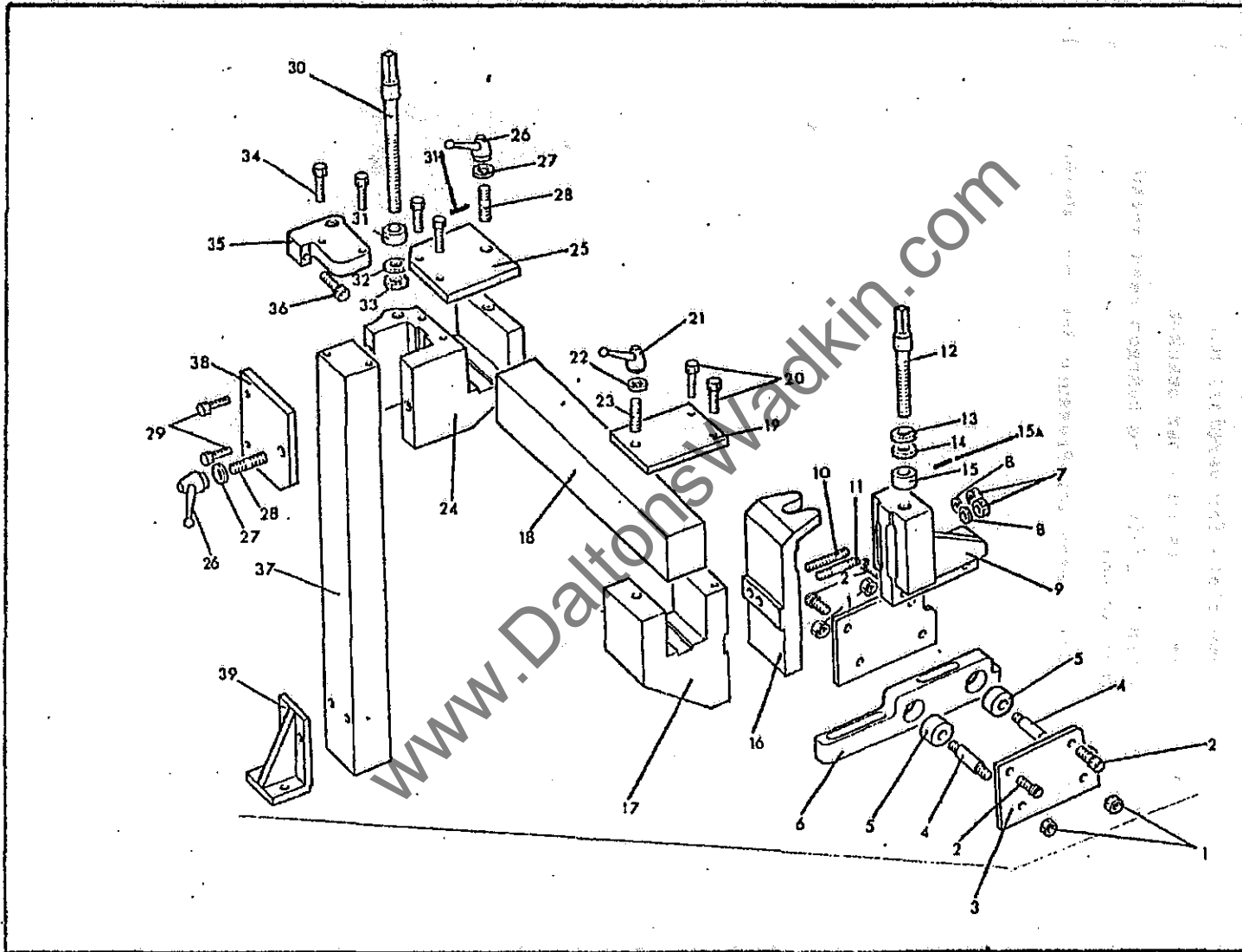

TOP PAD PRESSURE AFTER UNIVERSAL HEAD MODELS 1U and 5U

WIDE TOP PAD PRESSURE BEFORE UNIVERSAL HEAD MODELS 2U and 6U

Ref.No.	Part No.	Description	No. Off
1	K05 10 105	3/8in. whit. hexagon nut	4
2	K05 01 169	3/8in. whit. x 3/4in. hexagon hole capscrew	4
3	FB 13416	Side plate for pressure	2
4	FB 13414	Pin for top pad pressure	2
5	FB 13413	Rubber bush for top pad pressure	2
6	FB 13422	Bracket for pressure shoe	1
7	K05 10 107	1/2in. whit. standard nut	2
8	K05 11 126	1/2in. dia. washer	2
9	FB 13420	Holder for pressure	1
10	K05 08 483	1/2in. whit. x 4.1/2in. stud	1
11	K06 08 477	1/2in. whit. x 3in. stud	1
12	FB 2412	Screw for rise and fall	1
13	K06 10 145	'Torrington' thrust race TRA 1220	1
14	K06 10 106	'Torrington' needle thrust bearing NTA 1220	1
15	K05 20 103	3/4in. standard collar	1
15a	K05 20 486	Tension pin 4mm x 40mm	1
16	FB 13423	Bracket for pad pressure	1
17	FB 13424	Bracket for pressure	1
18	FB 1389	Horizontal pressure bar	1
19	FB 2416	Clamp plate for horizontal bar	1
20	K05 05 176	3/8in. whit. x 1in. long hexagon head screw	2
21	K05 21 450	1/2in. whit. x 15° adjustable handlever	1
22	K05 11 106	1/2in. dia. washer	1
23	K05 08 472	1/2in. whit. x 1.3/4in. long stud	1
24	FB 2413	Support bracket for horizontal bar	1
25	FB 2350	Clamp plate for horizontal bar	1
26	K05 21 450	1/2in. whit. x 15° adjustable handlever	2
27	K05 11 106	1/2in. dia. washer	2
28	K05 08 472	1/2in. whit. x 1.3/4in. stud	2
29	K05 05 176	3/8in. whit. x 1in. hex. head screws	4
30	FB 2413	Raising screw for roller pressure	1
31	K05 20 103	3/4in. dia. collar	1
31a	K05 20 486	Tension pin 4mm x 40mm	1
32	K06 10 145	'Torrington' thrust race TRA 1220	1
33	K06 10 106	'Torrington' Needle thrust bearing NTA 1220	1
34	K05 05 154	5/16in. whit. x 1.1/2in. hexagon head screws	2
35	FB 2318	Rise and fall bracket for pressures	1

WIDE TOP PAD PRESSURE BEFORE UNIVERSAL HEAD MODELS 2U and 6U (cont.)

Ref.No.	Part No.	Description	No. Off
36	K05 01 173	3/8in. whit. x 1.1/2in. long socket head capscrew	
37	FB 1366	Vertical pressure bar before Universal Head	1
38	FB 2417	Clamp plate for vertical bar	1
39	FB 1368	Vertical pressure bar bracket	1
40	K05 05 175	3/8in. x 3/4in. long hexagon head screw (not shown)	4

www.DaltonsWadkin.com

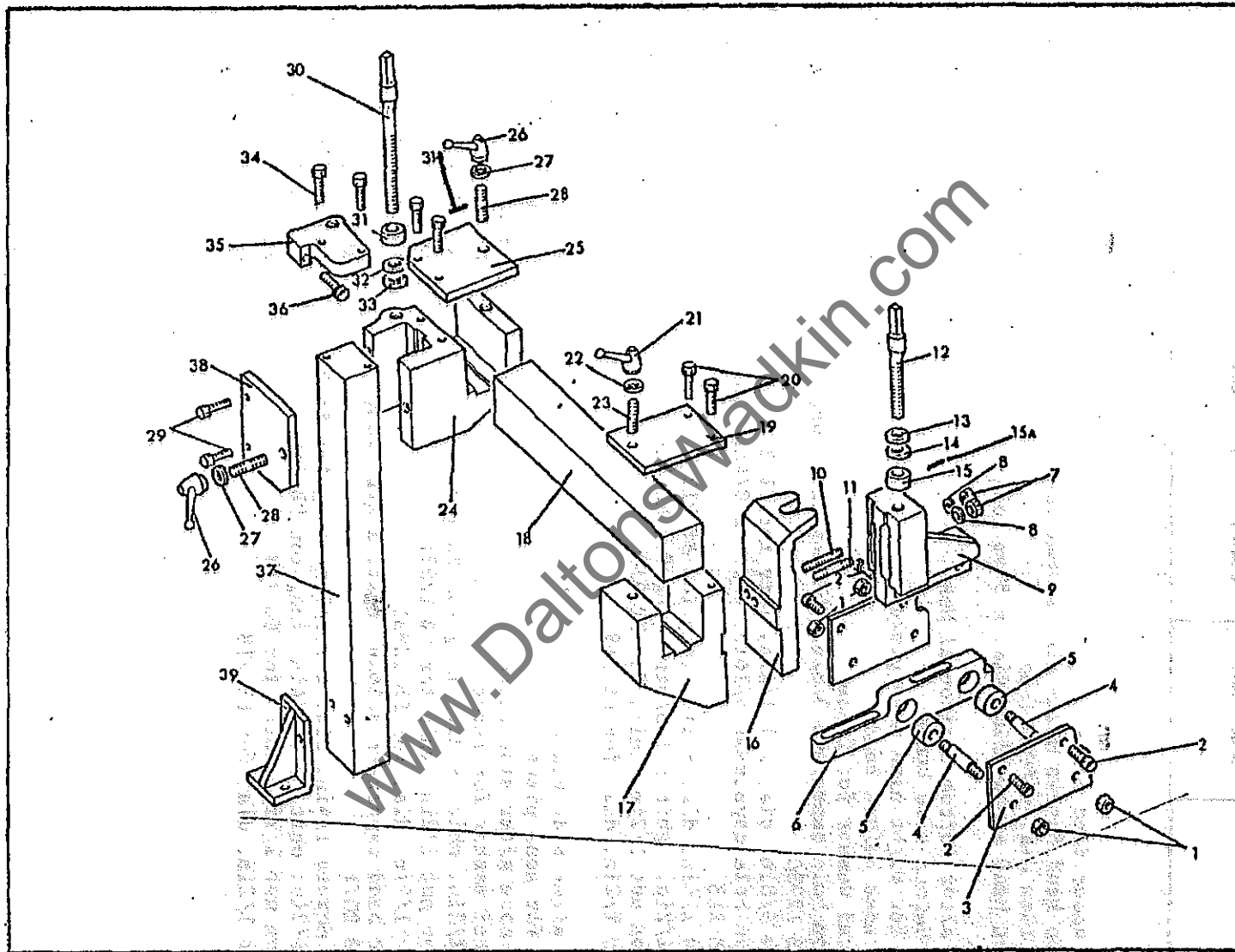

WIDE TOP PAD PRESSURE BEFORE UNIVERSAL HEAD MODELS 2U and 6U

FENCES FBN 230

Head Sequence and Number

MODEL	1	3	4	5
No.				
1	Btm. Hor.	Fence	Near	Top Hor.

	Part No.	No. Off
Fence under feed rolls	FB 14025	1
Hexagon head Screws M12mm dia. x 70mm long	K05 25 551	3
Dowel 10mm dia. x 60mm long	K05 29 163	2
Hexagon head screw M12mm dia. x 50mm long	K05 25 548	1
Fence after Bottom Horizontal Head		
Fence before side heads	FB 247	1
Plate for right hand nose piece	FB 213	1
Fence nose before head	FB 219	1
Serrated washer for fence	FB 229	1
Hexagon hole capscrews 3/8in. whit. x 1in. long for FB 12930	K05 01 171	2
Dowels 3/8in. dia. x 1.1/4in. long for FB 213	K05 20 637	2
Hexagon hole capscrews 5/16in. whit. x 3/4in. long for FB 213	K05 01 147	4
Dowels 1/4in. dia. x 1in. long for FB 213	K05 20 614	2
Stud 1/2in. whit x 1.3/4in. long for FB 219	K05 08 472	1
Hexagon nut 1/2in. whit. for FB 219	K05 10 107	1
Washer 1/2in. dia. for FB 219	K05 11 126	1
Fence after Side Heads		
Plate for nose piece	FB 12931	1
Fence nose after side heads	FB 2071	1
Serrated washer for fence	FB 218	1
Stud 1/2in. whit. x 2in. long for FB 12931	FB 229	1
Hexagon nut 1/2in. whit for FB 12931	K05 08 473	1
Washer 1/2in. dia. for FB 12931	K05 10 107	1
Socket head capscrews 3/16in. whit. x 1in. long for FB 2071	K05 11 106	1
Plain dowels 1/4in. dia. x 1.1/2in. long for FB 2071	K05 01 149	3
Stud 1/2in. whit. x 1.3/4in. long for FB 218	K05 20 616	2
Hexagon nut 1/2in. whit. for FB 218	K05 08 472	1
Washer 1/2in. dia. for FB 218	K05 10 107	1
	K05 11 106	1

Head Sequence and Number

MODEL	1	3	4	5	7
	No.	Btm. Hor.	Fence	Near	Top Hor.
2					

	Part No.	No. Off
Fence under feed rolls	FB 14025	1
Hexagon head screws M12 dia. x 70mm long	K05 25 551	3
Dowel 10mm dia. x 60mm long	K05 29 163	2
Hexagon head screw M12mm dia. x 50mm long	K05 25 548	1
Fence after bottom horizontal head		
Fence before side heads	FB 247	1
Plate for right hand nose piece	FB 213	1
Fence nose before head	FB 219	1
Serrated washer for fence	FB 229	1
Hexagon hole cap screws 3/8in. whit. x 1in. long for FB 12930	K05 01 171	2
Dowels 3/8in. dia. x 1.1/4in. long for FB 213	K05 20 637	2
Hexagon hole cap screw 5/16in. whit. x 3/4in. long for FB 213	K05 01 147	4
Dowels 1/4in. dia. x 1in. long for FB 213	K05 20 614	2
Stud 1/2in. whit. x 1.3/4in. long for FB 219	K05 08 472	1
Hexagon nut 1/2in. whit. for FB 219	K05 10 107	1
Washer 1/2in. dia. for FB 219	K05 11 126	1
Fence after side heads	FB 12945	1
Plate for nose piece	FB 2071	1
Fence nose after side heads	FB 218	1
Serrated washer for fence	FB 229	1
Stud 1/2in. whit. x 2in. long for FB 12931	K05 08 473	1
Hexagon nut 1/2in. whit. for FB 12931	K05 10 107	1
Washer 1/2in. dia. for FB 12931	K05 11 106	1
Socket head cap screws 5/16in. whit. x 1in. long for FB 2071	K05 01 149	3
Plain dowels 1/4in. dia. x 1.1/2in. long for FB 2071	K05 20 616	2
Stud 1/2in. whit. x 1.3/4in. long for FB 218	K05 08 472	1
Hexagon nut 1/2in. whit. for FB 218	K05 10 107	1
Washer 1/2in. dia. for FB 218	K05 11 106	1
Fence after second bottom horizontal head		
Fence for outfeed table	FC 68	2
Clamping bolt for outfeed table	FC 217	4
Hexagon nut 1/2in. whit. for FC 217	K05 10 107	4
Washer 1/2in. dia. for FC 217	K05 11 106	4

Head Sequence and Number

MODEL	1	2	3	4	5
No.					
5	Btm. Hor.	Top Hor.	Fence	Nearside	Top Hor.

	Part No.	No. Off
Fence under feed rolls	FB 14025	1
Hexagon head screws M12 dia. x 70mm long	K05 25 551	3
Dowel 10mm dia. x 60mm long	K05 29 163	2
Hexagon head screw M12mm dia. x 50mm long	K05 25 548	1
Fence after Bottom Horizontal Head		
Fence before side heads	FB 12930	1
Plate for right hand nose piece	FB 213	1
Fence nose before head	FB 219	1
Serrated washer for fence	FB 229	1
Hexagon hole cap screws 3/8in. whit. x 1in. long for FB 12930	K05 01 171	2
Dowels 3/8in. dia. x 1.1/4in. long for FB 213	K05 20 637	2
Hexagon hole cap screw 5/16in. whit. x 3/4in. long for FB 213	K05 01 147	4
Dowels 1/4in. dia. x 1in. long for FB 213	K05 20 614	2
Stud 1/2in. whit. x 1.3/4in. long for FB 219	K05 08 472	1
Hexagon nut 1/2in. whit. for FB 219	K05 10 107	1
Washer 1/2in. dia. for FB 219	K05 11 126	1
Fence after side heads		
Plate for nose piece	FB 2071	1
Fence nose after side heads	FB 218	1
Serrated washer for fence	FB 229	1
Stud 1/2in. whit. x 2in. long for FB 12931	K05 08 473	1
Hexagon nut 1/2in. whit. for FB 12931	K05 10 107	1
Washer 1/2in. dia. for FB 12931	K05 11 106	1
Socket head cap screws 5/16in. whit. x 1in. long for FB 2071	K05 01 149	3
Plain dowels 1/4in. dia. x 1.1/2in. long for FB 2071	K05 20 616	2
Stud 1/2in. whit. x 1.3/4in. long for FB 218	K05 08 472	1
Hexagon nut 1/2in. whit. for FB 218	K05 10 107	1
Washer 1/2in. dia. for FB 218	K05 11 106	1

Head Sequence and Number

Model	1	2	3	4	5	7
No.						
6	Btm. Hor.	Top Hor.	Fence	Near	Top Hor.	Btm. Hor.

	Part No.	No. Off
Fence under feed rolls	FB 14025	1
Hexagon head screws M12 mm dia. x 70mm long	K05 25 551	3
Dowel 10mm dia. x 60mm long	K05 29 163	2
Hexagon head screw M12mm dia. x 50mm long	K05 25 548	1
Fence after bottom horizontal head		
Fence before side heads	FB 12930	1
Plate for right hand nose piece	FB 213	1
Fence nose before head	FB 219	1
Serrated washer for fence	FB 229	1
Hexagon hole capscrews 3/8in. whit. x 1in. long for FB 12930	K05 01 171	2
Dowels 3/8in. dia. x 1.1/4in. long for FB 213	K05 20 637	2
Hexagon hole capscrew 5/16in. whit. x 3/4in. long for FB 213	K05 01 147	4
Dowels 1/4in. dia. x 1in. long for FB 213	K05 20 614	2
Stud 1/2in. whit. x 1.3/4in. long for FB 219	K05 08 472	1
Hexagon nut 1/2in. whit. for FB219	K05 10 107	1
Washer 1/2in. dia. for FB 219	K05 11 126	1
Fence after side heads	FB 12945	1
Plate for nose piece	FB 2071	1
Fence nose after side heads	FB 218	1
Serrated washer for fence	FB 229	1
Stud 1/2in. whit. x 2in. long for FB 12931	K05 08 473	1
Hexagon nut 1/2in. whit. for FB 12931	K05 10 107	1
Washer 1/2in. dia. for FB 12931	K05 11 106	1
Socket head capscrews 5/16in. whit. x 1in. long for FB 2071	K05 01 149	3
Plain dowels 1/4in. dia. x 1.1/2in. long for FB 2071	K05 20 616	2
Stud 1/2in. whit. x 1.3/4in. long for FB 218	K05 08 472	1
Hexagon nut 1/2in. whit. for FB 218	K05 10 107	1
Washer 1/2in. dia. for FB 218	K05 11 106	1
Fence after second bottom horizontal head		
Fence for outfeed table	FC 68	2
Clamping bolt for outfeed table	FC 217	4
Hexagon nut 1/2in. whit. for FC 217	K05 10 107	4
Washer 1/2in. dia. for FC 217	K05 11 106	4

Head Sequence and Number

MODEL	1	3	4	5	8
No.					
1U	Btm.Hor.	Fence	Near	Top. Hor.	Univ.

	Part No.	No. Off
Fence under feed rolls	FB 14025	1
Hexagon head screws M12mm dia. x 70mm long	K05 25 551	3
Dowel 10mm dia. x 60mm long	K05 29 163	2
Hexagon head screw M12mm dia. x 50mm long	K05 25 548	1
Fence after bottom horizontal head		
Fence before side heads	FB 247	1
Plate for right hand nose piece	FB 213	1
Fence nose before head	FB 219	1
Serrated washer for fence	FB 229	1
Hexagon hole cap screws 3/8in. whit. x 1in. long for FB12930	K05 01 171	2
Dowels 3/8in. dia. x 1.1/4in. long for FB 213	K05 20 637	2
Hexagon hole cap screw 5/16in. whit. x 3/4in. long for FB 213	K05 01 147	4
Dowels 1/4in. dia. x 1in. long for FB 213	K05 20 614	2
Stud 1/2in. whit. x 1.3/4in. long for FB 219	K05 08 472	1
Hexagon nut 1/2in. whit. for FB 219	K05 10 107	1
Washer 1/2in. dia. for FB 219	K05 11 126	1
Fence after side heads	FB 2079	1
Plate for nose piece	FB 2071	1
Fence nose after side heads	FB 218	1
Serrated washer for fence	FB 229	1
Stud 1/2in. whit. x 2in. long for FB 12931	K05 08 473	1
Hexagon nut 1/2in. whit. for FB 12931	K05 10 107	1
Washer 1/2in. dia. for FB 12931	K05 11 106	1
Socket head cap screws 5/16in. whit. x 1in. long for FB 2071	K05 01 149	3
Plain dowels 1/4in. dia. x 1.1/2in. long for FB 2071	K05 20 616	2
Stud 1/2in. whit. x 1.3/4in. long for FB 218	K05 08 472	1
Hexagon nut 1/2in. whit. for FB 218	K05 10 107	1
Washer 1/2in. dia. for FB 218	K05 11 106	1
Fence between second top horizontal head or universal head		
Front fence between 2nd top horizontal head and Universal head	FB 1482	1
Rear ditto	FB 1481	1
Stud 1.1/2in. long x 1/2in. whit for FB 1482	K05 08 471	2
Washer 1/2in. dia. for FB 1482	K05 11 106	2
Handlever 1/2in. whit. x 15° adjustable for FB 1482	K05 21 450	2
Taper pin No. 1 x 1.1/4in. long for handlever	K05 20 504	2
Hexagon head screw 1/2in. whit. x 1.1/2in. long for FB 1481	K05 05 226	2
Washer 1/2in. dia. for FB 1481	K05 11 106	2

MODEL No. 1U (continued)

	Part No.	No. Off
Fences after Universal Head		
Front fence after Universal Head	FB 1478	1
Rear fence after Universal Head	FB 1477	1
Stud 1.1/2in. long x 1/2in. whit. for FB 1482	K05 08 471	2
Washer 1/2in. dia. for FB 1482	K05 11 106	2
Handlever 1/2in. whit. x 15° adjustable for FB 1482	K05 21 450	2
Taper pin No. 1 x 1.1/4in. long for handlever	K05 20 504	2
Hexagon head screw 1/2in. whit. x 1.1/2in. long for FB 1481	K05 05 226	2
Washer 1/2in. dia. for FB 1481	K05 11 106	2

www.DaltonsWadkin.com

Head Sequence and Number

Model	1	3	4	5	7	8
No.						
2U	Btm. Hor.	Fence	Near	Top Hor.	Btm. Hor.	Univ.

	Part No.	No. Off
Fence under Feed Rolls	FB 14025	1
Hexagon head screws M12mm dia. x 70mm long	K05 25 551	3
Dowel 10mm dia. x 60mm long	K05 29 163	2
Hexagon head screw M12mm dia. x 50mm long	K05 25 548	1
Fence after bottom horizontal head		
Fence before side heads	FB 247	1
Plate for right hand nose piece	FB 213	1
Fence nose before head	FB 219	1
Serrated washer for fence	FB 229	1
Hexagon hole cap screws 3/8in. whit. x 1in. long for FB 12930	K05 01 171	2
Dowels 3/8in. dia. x 1.1/4in. long for FB 213	K05 20 637	2
Hexagon hole cap screw 5/16in. whit. x 3/4in. long for FB 213	K05 01 147	4
Dowels 1/4in. dia. x 1in. long for FB 213	K05 20 614	2
Stud 1/2in. whit. x 1.3/4in. long for FB 219	K05 08 472	1
Hexagon nut 1/2in. whit. for FB 219	K05 10 107	1
Washer 1/2in. dia. for FB 219	K05 11 126	1
Fence after side heads	FB 12945	1
Plate for nose piece	FB 2071	1
Fence nose after side heads	FB 218	1
Serrated washer for fence	FB 229	1
Stud 1/2in. whit. x 2in. long for FB 12931	K05 08 473	1
Hexagon nut 1/2in. whit. for FB 12931	K05 10 107	1
Washer 1/2in. dia. for FB 12931	K05 11 106	1
Socket head capscrews 5/16in. whit. x 1in. long for FB 2071	K05 01 149	3
Plain dowels 1/4in. dia. x 1.1/2in. long for FB 2071	K05 20 616	2
Stud 1/2in. whit. x 1.3/4in. long for FB 218	K05 08 472	1
Hexagon nut 1/2in. whit. for FB 218	K05 10 107	1
Washer 1/2in. dia. for FB 218	K05 11 106	1
Fence between second bottom head and Universal Head		
Front fence between second bottom horizontal head and universal head	FB 1470	1
Rear fence between 2nd bottom horizontal head and Universal head	FB 1469	1
Stud 1.1/2in. long x 1/2in. whit. for FB 1482	K05 08 471	2
Washer 1/2in. dia. for FB 1482	K05 11 106	2
Handlever 1/2in. whit. x 15° adjustable for FB 1482	K05 21 450	2
Taper pin No. 1 x 1.1/4in. long for handlever	K05 20 504	2

MODEL 2U (continued)

	Part No.	No. Off
Hexagon head screw 1/2in. whit. x 1.1/2in. long for FB 1481.	K05 05 226	2
Washer 1/2in. dia. for FB 1481.	K05 11 106	2
Fences after Universal Head		
Front fence after universal head	FB 1478	1
Rear fence after universal head	FB 1477	1
Stud 1.1/2in. long x 1/2in. whit.	K05 08 471	2
Washer 1/2in. dia.	K05 11 106	2
Handlever 1/2in. whit. x 15° adjustable	K05 21 450	2
Taper pin No.1 x 1.1/4in. long for handlever	K05 20 504	2
Hexagon head screw 1/2in. whit. x 1.1/2in. long	K05 05 226	2
Washer 1/2in. dia.	K05 11 106	2

www.DaltonsWadkin.com

Head Sequence and Number

Model	1	2	3	4	5	8
No.						
5U	Btm.Hor.	Top.Hor.	Fence	Near	Top Hor.	Univ.

	Part No.	No. Off
Fence under feed rolls	FB 14025	1
Hexagon head screws M12mm dia. x 70mm long	K05 25 551	3
Dowel 10mm dia. x 60mm long	K05 29 163	2
Hexagon head screws M12mm dia. x 50mm long	K05 25 548	1
Fence after bottom horizontal head		
Fence before side heads	FB 12930	1
Plate for right hand nose piece	FB 213	1
Fence nose before head	FB 219	1
Serrated washer for fence	FB 229	1
Hexagon hole cap screws 3/8in. whit. x 1in. long for FB 12930	K05 01 171	2
Dowels 3/8in. dia. x 1.1/4in. long for FB 213	K05 20 637	2
Hexagon hole cap screw 5/16in. whit. x 3/4in. long for FB 213	K05 01 147	4
Dowels 1/4in. dia. x 1in. long for FB 213	K05 20 614	2
Stud 1/2in. whit. x 1.3/4in. long for FB 219	K05 08 472	1
Hexagon nut 1/2in. whit for FB 219	K05 10 107	1
Washer 1/2in. dia. for FB 219	K05 11 126	1
Fence after side heads	FB 2079	1
Plate for nose piece	FB 2071	1
Fence nose after side heads	FB 218	1
Serrated washer for fence	FB 229	1
Stud 1/2in. whit x 2in. long for FB 12931	K05 08 473	1
Hexagon nut 1/2in. whit. for FB 12931	K05 10 107	1
Washer 1/2in. dia. for FB 12931	K05 11 106	1
Socket head capscrews 5/16in. whit. x 1in. long	K05 01 149	3
Plain dowels 1/4in. dia. x 1.1/2in. long for FB 2071	K05 20 616	2
Stud 1/2in. whit. x 1.3/4in. long for FB 218	K05 08 472	1
Hexagon nut 1/2in. whit. for FB 218	K05 10 107	1
Washer 1/2in. dia. for FB 218	K05 11 106	1
Fence between second top horizontal head and Universal head		
Front fence between second top horizontal head and universal head	FB 1482	1
Rear fence between second top horizontal head and universal head	FB 1481	1
Stud 1.1/2in. long x 1/2in. whit. for FB 1482	K05 08 471	2
Washer 1/2in. dia. for FB 1482	K05 11 106	2
Handlever 1/2in. whit. x 15° adjustable for FB 1482	K05 21 450	2
Taper pin No.1 x 1.1/4in. long for handlever	K05 20 504	2
Hexagon head screw 1/2in. whit. x 1.1/2in. long for FB 1481	K05 05 226	2
Washer 1/2in. dia. for FB 1481	K05 11 106	2

Model 5U (continued)

	Part No.	No. Off
Fences after Universal Head		
Front fence after Universal head	FB 1478	1
Rear fence after universal head	FB 1477	1
Stud 1.1/2in. long x 1/2in. whit. for FB 1482	K05 08 471	2
Washer 1/2in. dia. for FB 1482	K05 11 106	2
Handlever 1/2in. whit. x 15° adjustable for FB 1482	K05 21 450	2
Taper pin No. 1 x 1.1/2in. long for handlever	K05 20 504	2
Hexagon head screw 1/2in. whit. x 1.1/2in. long for FB 1481	K05 05 226	2
Washer 1/2in. dia. for FB 1481	K05 11 106	2

www.DaltonsWadkin.com

Head Sequence and Number

Model	1	2	3	4	5	7	8
No.							
6U	Btm.Hor.	Top Hor.	Fence	Near	Top Hor.	Btm.Hor.	Univ.

	Part No.	No. Off
Fence under feed rolls	FB 14025	1
Hexagon head screws M12mm dia. x 70mm long	K05 25 551	3
Dowel 10mm dia. x 60mm long	K05 29 163	2
Hexagon head screw M12mm dia. x 50mm long	K05 25 548	1
Fence after bottom horizontal head		
Fence before side heads	FB 12930	1
Plate for right hand nose piece	FB 213	1
Fence nose before head	FB 219	1
Serrated washer for fence	FB 229	1
Hexagon hole capscrews 3/8in. whit. x 1in. long	K05 01 171	2
Dowels 3/8in. dia. x 1.1/4in. long for FB 213	K05 20 637	2
Hexagon hole cap screw 5/16in. whit. x 3/4in. long for FB 213	K05 01 147	4
Dowels 1/4in. dia. x 1in. long for FB 213	K05 20 614	2
Stud 1/2in. whit. x 1.3/4in. long for FB 219	K05 08 472	1
Hexagon nut 1/2in. whit. for FB 219	K05 10 107	1
Washer 1/2in. dia. for FB 219	K05 11 126	1
Fence after side heads	FB 12945	1
Plate for nose piece	FB 2071	1
Fence nose after side heads	FB 218	1
Serrated washer for fence	FB 229	1
Stud 1/2in. whit. x 2in. long for FB 12931	K05 08 473	1
Hexagon nut 1/2in. whit. for FB 12931	K05 10 107	1
Washer 1/2in. dia. for FB 12931	K05 11 106	1
Socket head cap screws 5/16in. whit. x 1in. long	K05 01 149	3
Plain dowels 1/4in. dia. x 1.1/2in. long		
Stud 1/2in. whit. x 1.3/4in. long for FB 218	K05 08 472	1
Hexagon nut 1/2in. whit. for FB 218	K05 10 107	1
Washer 1/2in. dia. for FB 218	K05 11 106	1
Fence between second top horizontal head and Universal Head		
Front fence between second top horizontal head and universal head	FB 1482	1
Rear fence between second top horizontal head and universal head	FB 1481	1
Stud 1.1/2in. long x 1/2in. whit. for FB 1482	K05 08 471	2
Washer 1/2in. dia. for FB 1482	K05 11 106	2
Handlever 1/2in. whit. x 15° adjustable	K05 21 450	2
Taper pin No. 1 x 1.1/4in. long for handlever	K05 20 504	2
Hexagon head screw 1/2in. whit x 1.1/2in. long	K05 05 226	2
Washer 1/2in. dia. for FB 1481	K05 11 106	2

Model No. 6U (continued)

	Part No.	No. Off
Fences after Universal Head		
Front fence after universal head	FB 1478	1
Rear fence after universal head	FB 1477	1
Stud 1.1/2in. long x 1/2in. whit. for FB 1482	K05 08 471	2
Washer 1/2in. dia. for FB 1482	K05 11 106	2
Handlever 1/2in. x 15° adjustable for FB 1482	K05 21 450	2
Taper pin No.1 x 1.1/4in. long for handlever	K05 20 504	2
Hexagon head screw 1/2in. whit. x 1.1/2in. long for FB 1481	K05 05 226	2
Washer 1/2in. dia. for FB 1481	K05 11 106	2

www.DaltonsWadkin.com

BEDPLATES FBN 230

Head Sequence and Number

MODEL	1	3	4	5
No.				
1	Btm. Hor.	Fence	Near	Top Hor.

Bedplate Part No.

Bedplate before feed rolls (infeed)	FB 14024
Front Bedplate between bottom feed rolls	FB 14022
Rear Bedplate between bottom feed rolls	FB 14059
Bedplate before first bottom horizontal head	FB 14023
Bedplate (wide) after first bottom horizontal head	FB 12617
Bedplate for fence side head	FB 13017
Bedplate for near side head	FB 13012
Bedplate after side heads (2 off)	FB 12823
Bedplate under top horizontal head after side heads	FB 12820 (Permal)
Bedplate after second top horizontal head	FB 12826

MODEL No. 1

Jan. '78

page 147

Head Sequence and Number

MODEL No.	1	3	4	5	7
2	Btm. Hor.	Fence	Near	Top Hor.	Btm. Hor.

	Bedplate Part No.
Bedplate before feed rolls (infeed)	FB 14024
Front Bedplate between bottom feed rolls	FB 14022
Rear bedplate between bottom feed rolls	FB 14059
Bedplate before first bottom horizontal head	FB 14023
Bedplate (wide) after first bottom horizontal head	FB 12617
Bedplate for fence side head	FB 13017
Bedplate for near side head	FB 13012
Bedplate after side heads	FB 12823
Bedplate under top horizontal head after side head	FB 12820 (permal)
Bedplate before second bottom horizontal head	FB 12824
Table after second bottom horizontal head	FB 13203

MODEL No. 2

Head Sequence and Number

MODEL	1	2	3	4	5
No.					
5	Btm.Hor.	Top Hor.	Fence	Nearside	Top Hor.

	Bedplate Part No.
Bedplate before feed rolls (infeed)	FB 14024
Front bedplate between bottom feed rolls	FB 14022
Rear Bedplate between bottom feed rolls	FB 14059
Bedplate before first bottom horizontal head	FB 14023
Bedplate (wide) after first bottom horizontal head	FB 12617
Bedplate under first top horizontal head	FB 12827
Bedplate for fence side head	FB 13017
Bedplate for near side head	FB 13012
Bedplate after side head (2 off)	FB 12823
Bedplate under top horizontal head after side head	FB 12820 (Permal)
Bedplate after second top horizontal head	FB 12826

Head Sequence and Number

Model	1	2	3	4	5	7
No.						
6	Btm. Hor.	Top Hor.	Fence	Near	Top Hor.	Btm.Hor.

Bedplate Part No.

- Bedplate before feed rolls (infeed) FB 14024
- Front bedplate between bottom feed rolls FB 14022
- Rear bedplate between bottom feed rolls FB 14059
- Bedplate before first bottom horizontal head FB 14023
- Bedplate (wide) after first bottom horizontal head FB 12617
- Bedplate under first top horizontal head FB 12827
- Bedplate for fence side head FB 13017
- Bedplate for near side head FB 13012
- Bedplate after side heads FB 12823
- Bedplate before second bottom horizontal head FB 12824
- Table after second bottom horizontal head FB 13023

Head Sequence and Number

MODEL No.	1	3	4	5	8
1U	Btm.Hor.	Fence	Near	Top Hor.	Univ.

	Bedplate part No.
Bedplate before Feed Rolls (infeed)	FB 14024
Front bedplate between Bottom Feed Rolls	FB 14022
Rear bedplate between Bottom Feed Rolls	FB 14059
Bedplate before first Bottom Horizontal Head	FB 14023
Bedplate (wide) after first Bottom Horizontal Head	FB 12617
Bedplate for Fence Side Head	FB 13017
Bedplate for Near Side Head	FB 13012
Bedplate after Side Heads (2 off)	FB 12823
Bedplate under Top Horizontal Head after Side Heads	FB 12820 (Permal)

Head Sequence and Number

Model No.	1	3	4	5	7	8
2U	Btm.Hor.	Fence	Near	Top Hor.	Btm.Hor.	Univ.

	Bedplate Part No.
Bedplate before feed rolls (infeed)	FB 14024
Front bedplate between bottom feed rolls	FB 14022
Rear bedplate between bottom feed rolls	FB 14059
Bedplate before first bottom horizontal head	FB 14023
Bedplate (wide) after first bottom horizontal head	FB 12617
Bedplate for fence side head	FB 13017
Bedplate for near side head	FB 13012
Bedplate after side heads	FB 12823
Bedplate under top horizontal head after side head	FB 12820 (Permal)
Bedplate before second bottom horizontal head	FB 12824

Head Sequence and Number

Model:	1	2	3	4	5	8
No.						
5U	Btm. Hor.	Top. Hor.	Fence	Near	Top Hor.	Univ.

Bedplate Part No.

Bedplate before feed rolls (infeed)	FB 14024
Front bedplate between bottom feed rolls	FB 14022
Rear bedplate between feed rolls	FB 14059
Bedplate before first bottom horizontal head	FB 14023
Bedplate (wide) after first bottom horizontal head	FB 12617
Bedplate under first top horizontal head	FB 12827
Bedplate for fence side head	FB 13017
Bedplate for near side head	FB 13012
Bedplate after side heads (2 off)	FB 12823
Bedplate under top horizontal head after side heads	FB 12820 (permali)

Head Sequence and Number

MODEL	1	2	3	4	5	7	8
No.							
6U	Btm.Hor.	Top Hor.	Fence	Near	Top Hor.	Btm.Hor.	Univ.

Bedplate Part No.

- Bedplate before feed rolls (infeed) FB 14024
- Front bedplate between bottom feed rolls FB 14022
- Rear bedplate between bottom feed roll FB 14059
- Bedplate before first bottom horizontal head FB 14023
- Bedplate (wide) after first bottom horizontal head FB 12617
- Bedplate under first top horizontal head FB 12827
- Bedplate for fence side head FB 13017
- Bedplate for near side head FB 13012
- Bedplate after side heads (2 off) FB 12823
- Bedplate under top horizontal head after side head FB 12820
- Bedplate before second bottom horizontal head FB 12826

MODEL No. 6U

Jan. '78

UNIVERSAL HEAD

General

A universal head can follow either a top head or a bottom head. Machines so supplied have the suffix 'U' after the model number.

Construction

The slide is part of a substantial iron casting carried on an 'L' shaped fabrication bolted to the end of the body and carries an upper stand unit to which is bolted an extension to the longitudinal beam. An outfeed table with rise and fall and lateral adjustment is mounted on the outside of the vertical 'L' shape.

Spindle

The spindle is 40mm with 40° included angle integral cone and fitted with double keys to allow for direction reversal with a totally enclosed timing belt drive from the motor. The spindle is approximately 195mm long for 150mm long cutterblocks, but longer blocks can be accommodated by recessing the cone and nut. Speeds of 6000 and 3000 r.p.m. are standard.

Electrical Equipment.

The motor is a 7.5/5.5 kW (10/7.5 h.p.) 2 speed TEFC unit running at 3000/1500 rev/min. Start, stop, 2 speed and forward and reverse controls are mounted in a control box on the main frame adjacent to the universal head. Where a 'Rotor Push' direction and start push switch is fitted, before depressing the start pushbutton - turn the barrel of the push switch to select the spindle direction.

Dust Extraction

A variety of dust hoods is available to suit the application.

Pressures

Standard pad pressures are mounted before and behind the unit.

Application

The long movements of both horizontal and vertical slides, together with the worm and wheel canting features, allow the spindle to be positioned as a top, bottom, fence or front side head and in any intermediate position of cant. In addition, the open construction allows the fitting of large diameter saws for splitting and sill throating.

ADJUSTMENTS

HORIZONTAL.....FIG.2.

The complete Universal Head assembly can be traversed laterally by movement of the slide via square (1) from either the front or rear of the machine locking lever (2) holds this movement.

VERTICAL.....:FIG.3.

A vertical slide unit mounted on the horizontal saddle may be adjusted via square (3) three locking nuts (4) are provided to hold this movement.

Both of the above movements can be used to provide for either top or bottom head positions. By positioning the spindle in a vertical mode the spindle can then be used as front or fence side head.

CANTING.....FIG.4.

The spindle can be positioned 110° back or forward to the vertical and locked in any intermediate position. A cranked handle is fitted to the worm drive square (5) at either the front or rear of the machine, three locking nuts (6) secure the canted head.

A canted head cutting position can be selected above or below the table

Various table sections can be fitted to suit the mode of machining, a dust extraction hood is supplied and must be fitted to the mounting collar inboard of the cutter. The hood and collar are adjustable for the various positions of the head.

OUTFEED TABLE (machine)

When a Universal head follows a second bottom head various 'infill' table sections are available to suit the cutting circles of both heads. This table section is set vertically as the outfeed to the last bottom head.

OUTFEED TABLE (Universal Head).....FIG.1.

This table section is set in the vertical by means of adjustment on a 30° slideway via knob (1), locking lever (2) holds the movement.

The table section can be adjusted to clear the cutting circle, two locking points for this section are located on the underside of the table.

Reference should be made to the Pressure Section of this manual for the various fixtures and arrangements.

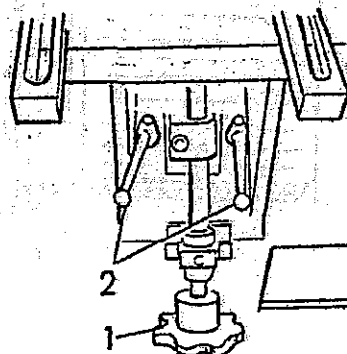

FIG 1

UNIVERSAL HEAD DRIVE - BELT REPLACEMENT

TO REMOVE BELT

- 1) Remove screws (A) and cover (B).
- 2) Remove screws (C) then screws (D) from the rear bearing assembly (E).
- 3) Remove screws (N) and retaining ring (O).
- 4) Remove nut (P) from the spindle then replace retaining ring (O) to hold the bearings.
- 5) Remove screws (M) and cover (L).
- 6) Remove two screws (K) from taper-lock bush (J).
- 7) Use one of these screws (K) in the third hole to jack off the taper lock bush (J).
- 8) Disengage belt (F) from pulley and remove pulley (H).
- 9) Move belt (F) off the motor spindle and form a loop in the spindle housing and then remove the spindle from the rear of the spindle housing.
- 10) Withdraw the belt through the motor drive cavity.

TO FIT NEW BELT

- 11) Reverse the above procedure.

NOTE: When replacing the spindle ensure the bearing and spacers are not damaged and are correctly positioned.

- 12) Before cover (L) is replaced, it may be found necessary to adjust the tension in the belt. (The belt should not be too tight, not too loose). When one side of the belt span is depressed, it should deflect approximately 3mm. (5/32in.).

To tension the belt, slacken off four bolts (G) and move motor mounting plate.

NOTE: Once the belt tension is set correctly, it will not require retensioning.

