



**C500 - C700**

**BANDSAWS**

INSTRUCTION MANUAL No.3035/1



# C500 - C700

## BANDSAWS

MACHINE No.	
TEST No.	
YEAR OF MANUFACTURE	

**MANUFACTURERS E.C. DECLARATION  
OF CONFORMITY**

The following machine has undergone "Conformity Assessment" and has undergone Third Party Examination by a Notified Body in accordance with:-

Schedule IV of the Supply of Machinery (Safety) Regulations 1992 and Amendment No. 2063

**COMPANY**

Wadkin Ultracare Limited  
Hilltop Industrial Park  
Bardon Hill  
Coalville  
LE67 1TT

**RESPONSIBLE PERSON**

Mr J P Smith (Director)

**MACHINE DESCRIPTION**

**TYPE** Table Bandsaw

**MODEL** C Range

**DIRECTIVES COMPLIED WITH**

Supply of Machinery (Safety) Regulations 1992  
Amendment No. 2063 1994  
Draught Proposal CEN/TC 142  
ISO 9001 Part 1

**NOTIFIED BODY**

Lloyds Register  
Lloyds Register House  
29 Wellesley Road  
Croydon, CR0 2AJ

**SIGNED ON BEHALF OF WADKIN  
ULTRACARE LTD.**

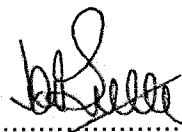

**EC TYPE EXAMINATION  
CERTIFICATE NO.**

EC95/00003



## EC Type Examination Certificate

Certificate Number: EC 95/00003 A1

Office: UK Industry – Statutory Services

Date: 20 February 1995

*This is to certify that Lloyd's Register of Shipping, an Approved Body under the terms of; The Machinery Directive 89/392/EEC as amended by Directives 91/368/EEC, 93/44/EEC and 93/68/EEC as consolidated by Directive 98/37/EC. The Supply of Machinery (Safety) Regulations 1992, Statutory Instrument 1992 No. 3073 as amended by Statutory Instrument 1994 No. 2063 did undertake an EC Type Examination on the stated product for compliance with the essential safety requirements of the Directive. The product identified below was shown to comply. This certificate is issued to*

**APPLICANT**                      Wadkin Ultracare Limited,  
Green Lane Road,  
Leicester LE5 4PF,  
England.

**PRODUCT DESCRIPTION**                      "C" Range Table Band Saws

**TYPE**    C500 and C700

*The attached LR Design Appraisal Document No. EC95/00003 issue 2 details the content of the Technical Construction File and shall form a part of this certificate.*

*"This Certificate is not valid for equipment, the design, ratings or operating parameters of which have been varied from the specimen tested. The manufacturer should notify LR of any modification or changes to the equipment in order to obtain a valid certificate."*

**M.R. GREENHALGH**

**Surveyor to Lloyd's Register**

**LR EC Distinguishing Number 0038**

**BE CAREFUL  
THIS MACHINE CAN BE DANGEROUS  
IF IMPROPERLY USED**

Always use guards.  
Keep clear until rotation has ceased.  
Always operate as instructed  
and in accordance with good practice.  
Read instruction manual before installing,  
operating or maintaining machine.

*Manufactured by : WADKIN PLC  
Franks Road  
Hilltop Industrial Park  
Bardon Hill  
Coalville, LE67 1TT  
England*

*Telephone No. : +44(0)870 850 9111  
Fax No. : +44(0)870 240 0575  
Website : [www.wadkinultracare.com](http://www.wadkinultracare.com)  
E mail : [info@wadkinultracare.com](mailto:info@wadkinultracare.com)*



# CONTENTS

## EXTENT OF MANUAL

Section		Page
<b>1</b>	<b>HEALTH AND SAFETY</b>	<b>1-1</b>
1.1	Health and Safety	1-1
1.1.1	Factories Act	1-1
1.1.2	Health and Safety at Work Act	1-2
1.1.3	Electricity Regulations	1-2
1.1.4	Provisions and use of Work Equipment Regulations	1-2
1.1.5	Woodworking Machines Regulations	1-2
1.1.6	Other Documents for Reference	1-2
1.2	Supply of Machinery (Safety) Regulations 1992	1-3
1.3	Specific Information	1-3
1.3.1	Noise	1-3
1.3.2	Dust	1-4
<b>2</b>	<b>MACHINE SPECIFICATION</b>	<b>2-1</b>
<b>3</b>	<b>INSTALLATION</b>	<b>3-1</b>
3.1	Receipt of the Machine	3-1
3.2	Preparation for Installation	3-1
3.3	Lifting and Locating the Machine	3-1
3.4	Connecting the Services	3-2
3.4.1	Electrical Supply	3-2
3.4.2	Dust Extraction	3-3
<b>4</b>	<b>MACHINE USAGE AND CONTROLS</b>	<b>4-1</b>
4-1	Safe Practices	4-1
4.1.1	Pre-operation Checks	4-1
4.1.2	Checks During Operation	4-1
4.2	Machine Controls	4-2
4.2.1	Machine Control Panel	4-2
4.2.2	Saw Blade Tensioner	4-2
4.2.3	Guarding	4-2
<b>5</b>	<b>SETTING-UP THE MACHINE</b>	<b>5-1</b>
5.1	General	5-1
5.1.1	Preparation	5-1
5.2	Fitting a Saw Blade	5-1
<b>Section</b>		<b>Page</b>

5.3	Tracking a Saw Blade	5-2
5.4	Tensioning a Saw Blade (using Tensioning Scale)	5-3
5.5	Setting the Top Saw Guide Unit	5-4
5.6	Adjusting the Height of the Top Saw Guide Unit	5-5
5.7	Setting the Bottom Saw Guide Unit	5-5
5.8	Setting the Table Cant Adjustment	5-6
5.9	Setting the Table/Saw Blade Squareness	5-6
5.10	Setting the Rip Fence	5-7
<b>6</b>	<b>OPERATION</b>	<b>6-1</b>
6.1	General	6-1
6.1.1	Pre-operation Checks	6-1
6.1.2	Setting Controls and Adjustments	6-1
<b>7</b>	<b>MAINTENANCE</b>	<b>7-1</b>
7.1	General	7-1
7.2	Scheduled Maintenance	7-1
7.2.1	Daily	7-1
7.2.2	Weekly	7-2
7.2.3	Monthly	7-2
7.3	Unscheduled Maintenance	7-2
7.3.1	Re-tension Electric Motor Drive Belt	7-3
7.3.2	Remove Top and Bottom Wheels	7-4
<b>8</b>	<b>GENERAL INFORMATION</b>	<b>8-1</b>
8.1	Advice on Cutting	8-1
8.2	Bandsaw Blades	8-1

## EXTENT OF MANUAL

---

This Operation and Maintenance Manual is intended to provide users with all relevant information concerning the operation and maintenance of Heavy Duty Thicknesser machine model TD630.

The document is produced in eight sections.

Section Two to Four gives advice general safety aspects of the machine usage including references to the various current statutory and safety regulations in force, advice on record keeping of machine operation and maintenance, and also instructions on recommended procedures when accepting and receiving the machine from the manufacturer.

Sections Five to Seven provide the information necessary to operate and maintain the machine.

Section Eight provides the user with general helpful information on the ordering of spare parts for the machine.

The policy of the Company is one of continuous development, and the company reserves the right to alter specification without prior notice.

No part of this publication shall be produced in any way without the express permission of the Company.

© 1997.



# 1 HEALTH AND SAFETY

---

This Section covers all aspects of safe operation and safe use of woodworking machinery. It refers to various statutory Health and Safety regulations, and also includes information and advice derived from many years' experience in the in the building, operation and maintenance of woodworking machinery.

**It is of the utmost importance that the user or employer reads this Section of the document and understands clearly all of the stated requirements concerning safe operation of the equipment.**

## 1.1 Health and Safety

There are a number of statutory regulations which apply to the safe operation of woodworking machinery in the UK. These regulations are listed below, and the user is advised to refer to the relevant parts of these regulations and ensure that the requirements are complied with.

Where the machinery is used outside the UK, then the regulations of that country will apply, and should be complied with.

*Note:*

*The list below relates to the most recent published editions of the regulations including all amendments and supplements.*

Factories Act.

Health and Safety at Work Act.

Electricity Regulations.

Provision and use of Work Equipment Regulations.

Woodworking Machines Regulations.

### 1.1.1 Factories Act

This Act requires that rotating machinery shall be of good mechanical construction and that it shall be **properly maintained and serviced by competent and experienced persons.**

### 1.1.2 **Health and Safety at Work Act**

This Act imposes obligations to apply similar standards to those of the Factories Act as a minimum requirement, **especially where a machine is installed in a place of work where no suitable legislation applies.**

### 1.1.3 **Electricity Regulations**

These regulations place general requirements on the installation and maintenance of electrical equipment. Users should be aware of the requirements concerning the availability of lighting and free working space for maintenance personnel, and the importance of personnel being fully competent and trained when working on electrical equipment.

### 1.1.4 **Provision and use of Work Equipment Regulations**

Compliance with these regulations is necessary for equipment to be considered to be conforming with the EC declaration of conformity.

The regulations also place obligations on the user (see Section 1.2).

### 1.1.5 **Woodworking Machines Regulations**

These regulations place absolute legal requirements on employers and users to ensure **that all fitted guards and safety devices are always used, securely fitted, correctly adjusted and properly maintained.**

The regulations also require that **maintenance be undertaken only by suitably qualified and competent personnel, and that all power supplies are isolated from the machine before any maintenance is undertaken.**

It is also required that **operators (users) receive suitable training and instruction into the possible dangers arising from machine usage and that local working practices are followed.**

### 1.1.6 **Other Documents for Reference**

Other documents which refer to woodworking machinery operation and maintenance in the UK include:

Noise at Work Regulations.

Control of Substances Hazardous to Health Regulations.

Code of Practice BS5304 - Safeguard of Machinery.

Code of Practice BS6854 - Safeguard of Woodworking Machines.

Health and Safety Executive note IND(G) 1(L).

## 1.2 Supply of Machinery (Safety) Regulations 1992

A machine manufactured in accordance with the Essential Health and Safety Requirements of the Supply of Machinery (Safety) Regulations 1992, complies with the EC conformity requirements and can thus have the CE mark appended (Harmonised Standard PREN 12750: 1997) .

These regulations also impose legal requirements on both the employer and the user of the machine with regard to proper usage, user working conditions, risks of injury and many more. These requirements are wide ranging, and in some cases specific to only certain types of machine or process. Some of the more general requirements which apply to woodworking machinery are briefly detailed below.

- 1 An employer shall ensure that the equipment is constructed/adapted as to be suitable for the purpose that it is used.
- 2 In selecting the equipment, the employer shall have due regard to the working conditions and the risks to health and safety of persons which exist in the premises in which the equipment is to be used.
- 3 The employer shall ensure that the equipment is used for the operations for which, and under the conditions for which it is suitable.

Other requirements include provision of suitable training of users, provision of suitable documentation (information and instructions), and declarations of any specific risks.

## 1.3 Specific Information

Various sections of this manual detail general safe working practices and specific local practices which should be adopted when using the machine. In addition to this information two hazards, specific to woodworking machinery should be considered in more detail.

### 1.3.1 Noise

Noise levels can vary widely depending upon the machine and the conditions of use.

The Noise at Work Regulations place legal duties on employers to prevent damage to hearing. Noise levels of up to 140dB are considered.

**Employers** are required to take reasonably practicable measures to reduce noise levels where a person is expected to be exposed to continuous noise in excess of 90dB over a working day. Additionally suitable ear protection must be made available.

Machines producing 'unhealthy noise levels' must be marked with a warning of the need to wear ear protection.

Additionally, it may be necessary to identify particular areas of the workplace 'ear protection zones'.

### 1.3.2 Dust

Wood dust can be harmful to health through inhalation and also skin contact.

The Control of Substances Hazardous to Health Regulations place legal requirements on **employers** to prevent exposure of the user to substances hazardous to health or, where prevention is not practicable, to adequately control the exposure. Adequate control should be achieved by measures other than provision of personal protective equipment.

The Regulations require that airborne dust levels should not exceed  $5\text{mg}/\text{m}^3$ .

www.DaltonsWadkin.com

## 2 MACHINE SPECIFICATION

---

	<b>C5</b>	<b>C7</b>
Diameter of wheels (mm/in)	500/19.7	700/27.5
Width of saw blade (mm/in)	25/1	40/1.6
Max length of saw blade (mm/in)	4191/165	5080/200
Min length of saw blade (mm/in)	4115/62	4902/193
Max cut width (mm/in)	480/18.9	680/26.7
Size of table (mm/in)	500x700 19.7x27.5	765x1000 30x39
Floor space (mm/in)	550x890 21.7x35	770x1340 30x52.7
Weight (kg/lbs)	220/485	483/1064

www.DaltonsWadkin.com

## 3 INSTALLATION

---

### 3.1 Receipt of the Machine

Before accepting the machine at its destination check the packages/items against the bill of loading. Confirm that all listed fittings/accessories have been received and carry out a visual inspection of the packages/items for obvious signs of damage.

Report any omissions or damage; note these for any future reference.

### 3.2 Preparation for Installation

Ensure that the necessary electrical supply is available (as identified on the machine Specification Plate), and that this supply can be isolated external to the machine.

Check also that adequate space is available on the installation site for lifting and manoeuvring access.

Check that suitable and approved lifting equipment is available and is of adequate capacity.

Refer to the Foundation Plan for details of the floor area required and for foundation bolt positions.

Ensure that the final location of the machine has been levelled.

### 3.3 Lifting and Locating the Machine

With the machine top door open, place a sling of minimum length 5m and having a capacity within the safe working load around the top frame and behind the top wheel.

*Note:*

*To avoid damage to the frame and sling locate soft packaging (waste material, etc. between the sling and machine where contact occurs).*

Secure the top door to the top saw guide rise and fall locking handwheel using a cord or rope of necessary strength.

With the lifting equipment lift and position the machine on the prepared location.

**WARNING:**

**The machine must be firmly bolted down before connecting the electrical supply and any other services.**

Remove any protective coatings/applications from the machine surfaces.

**Note:**

If the machine is received unassembled (normally for overseas destinations), re-assembly must be undertaken before any part of the machine is installed.

This necessitates affixing the top cover to the main frame, the top wheel to its spindle fitting, and locating the top and bottom doors.

Refer to Figures 3.3.1 and 3.3.2 for details of the fixing methods when assembling the machine.

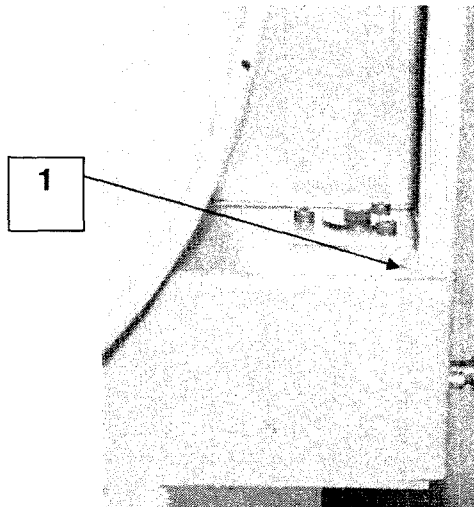

Fix the top cover to the main frame using bolts (1)

**Figure 3.3.1**

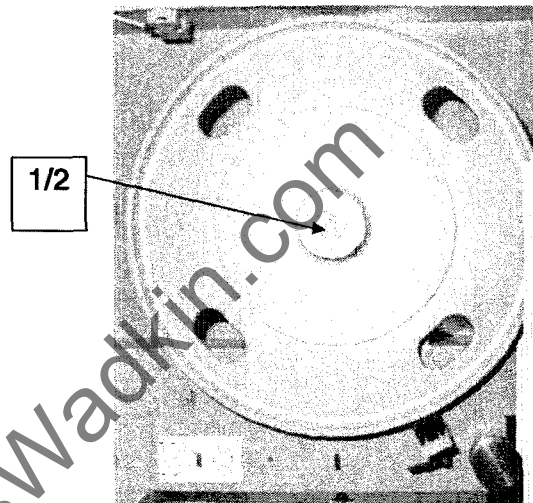

Secure the top wheel to the spindle with bolt (1) and washer (2)

**Figure 3.3.2**

## **3.4 Connecting the Services**

### **3.4.1 Electrical Supply**

The customer is responsible for an electrical supply suitable to meet the power requirements of the machine. These requirements are shown on the machine Specification Plate on the machine frame, and are also shown on the electrical schematic/connection diagram accompanying the machine.

Electrical connections should be made to the isolating switch on the electrical control cubicle.

**WARNING:**

Connection of the supply must be made by a competent and experienced electrician.

The connection procedure should include, but not be limited to:

Confirm that the supply is of the correct voltage, phase and frequency to that identified on the machine Specification Plate.

Check that the incoming fuse ratings can accommodate the full load current shown on the machine Specification Plate.

Ensure that the external electrical supply isolator is open before connecting the incoming supply to the relevant terminals on the machine control box (L1, L2 and L3).

Make a good earth connection to the machine.

**WARNING:**

**Before undertaking the following operation ensure that all relevant safety requirements and procedures detailed in Section 1 are complied with.**

Close the external isolator and run the machine to ensure that motor direction of rotation is correct.

*Note:*

*Incorrect rotation of the motor can be corrected by reversing any two of the incoming supply connections to the terminals of the machine control box.*

**WARNING:**

**Phase changes must be made by a competent and experienced electrician.**

**3.4.2 Dust Extraction**

The customer is responsible for the supply and fitting of suitable dust extraction equipment.

Equipment can be fitted to the 100mm dust extraction outlet located on the bottom frame of the machine.

**WARNING:**

**It is advisable to connect and use dust extraction equipment.**



## 4 MACHINE USAGE AND CONTROLS

---

*Note:*

*Refer also to Section 1 for information on general statutory requirements when operating woodworking machinery.*

### 4.1 Safe Practices

Safe and proper working practices must be followed when setting-up and operating the machine. Adequate advice and information are readily available in the form of local working practices, notices, warnings and the information contained in this manual.

**IT IS THE OPERATOR'S RESPONSIBILITY TO USE THE MACHINE FOLLOWING THE PROCEDURES LAID DOWN AND ONLY FOR THE PURPOSES FOR WHICH IT WAS DESIGNED.**

#### 4.1.1 Pre-operation Checks

All guards are fitted securely and properly adjusted to suit their purpose.

Bandsaw blades are correctly fitted and tensioned.

Dust extraction equipment is working correctly.

Machine controls are functioning correctly.

Adequate working space is provided and lighting is available.

#### 4.1.2 Checks During Operation

Proper protective equipment is available and employed where necessary and/or recommended (goggles, ear defenders, face mask, etc).

Area around the machine is kept clean and free of refuse.

Any machine malfunction is recorded and reported to person in authority.

Machine is made stationary and electrically isolated before any cleaning of work area or ANY adjustments are made to the machine or any ancillary equipment.

## 4.2 Machine Controls

### 4.2.1 Machine Control Panel

Before using the machine, operators should familiarise themselves with the machine controls.

#### Machine Start/Stop (Figure 4.2.1)

The machine Start and Stop pushbutton controller (1) is located on the machine column.

### 4.2.2 Saw Blade Tensioner (Figure 4.2.2)

The machine saw blade can be tensioned using a tensioner. (The tensioning procedure is covered in Section 5).

### 4.2.3 Guarding (Figure 4.2.1)

Top and bottom saw guards (2) are fitted to the machine. These guards should always be checked before the machine is used.

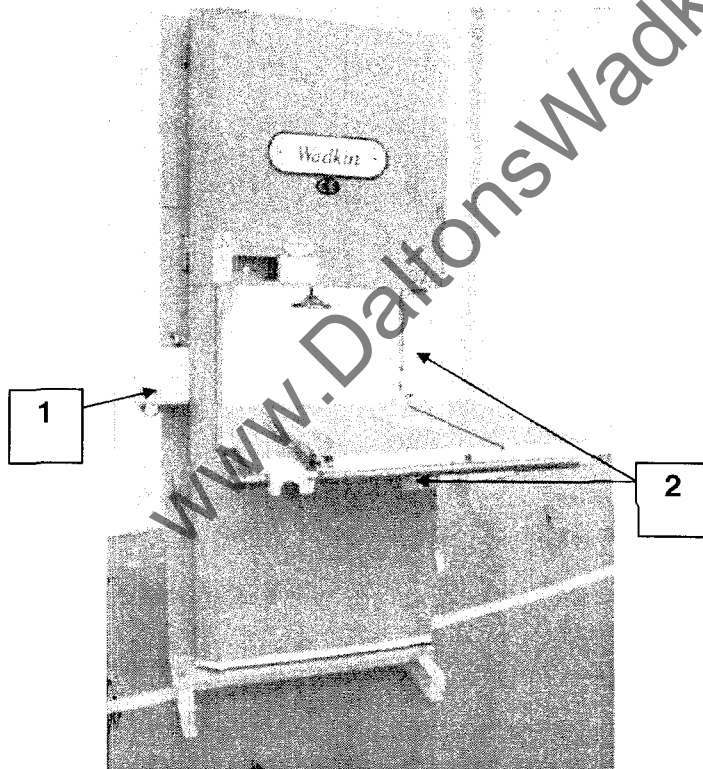

Figure 4.2.1

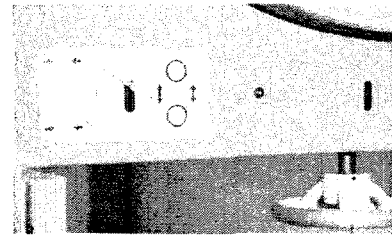

Figure 4.2.2

## 5 SETTING-UP THE MACHINE

---

### 5.1 General

This Section describes the procedures to set-up a bandsaw machine.

These procedures include fitting, tracking and tensioning a saw blade, setting the saw guide units, and adjusting the table.

#### 5.1.1 Preparation

Before beginning the setting-up procedure carry out the following checks:

- 1 Adequate working space is provided and lighting is available.
- 2 Proper protective equipment (goggles, ear defenders, face mask, etc) is available and employed if required.
- 3 Area around the machine is clean and free of wood refuse.
- 4 The machine is electrically isolated.

Equipment required:

- 1 Standard tool kit.
- 2 Set square.

### 5.2 Fitting a Saw Blade (Figure 5.2)

**WARNING:**

**ENSURE THAT THE MACHINE IS ELECTRICALLY ISOLATED BEFORE PROCEEDING.**

- 1) Open the machine top and bottom doors.
- 2) Slacken and remove bolts (1) and remove the top saw guard (2).
- 3) Slacken bolt (3) and move the top saw guide (4) to the extreme rear position.
- 4) Using handwheel (5) lower the top wheel assembly sufficiently to permit the saw blade to be fitted over both top and bottom wheels.
- 5) Insert the blade through slot (6) adjacent to the pushbutton controller and locate over both wheels.

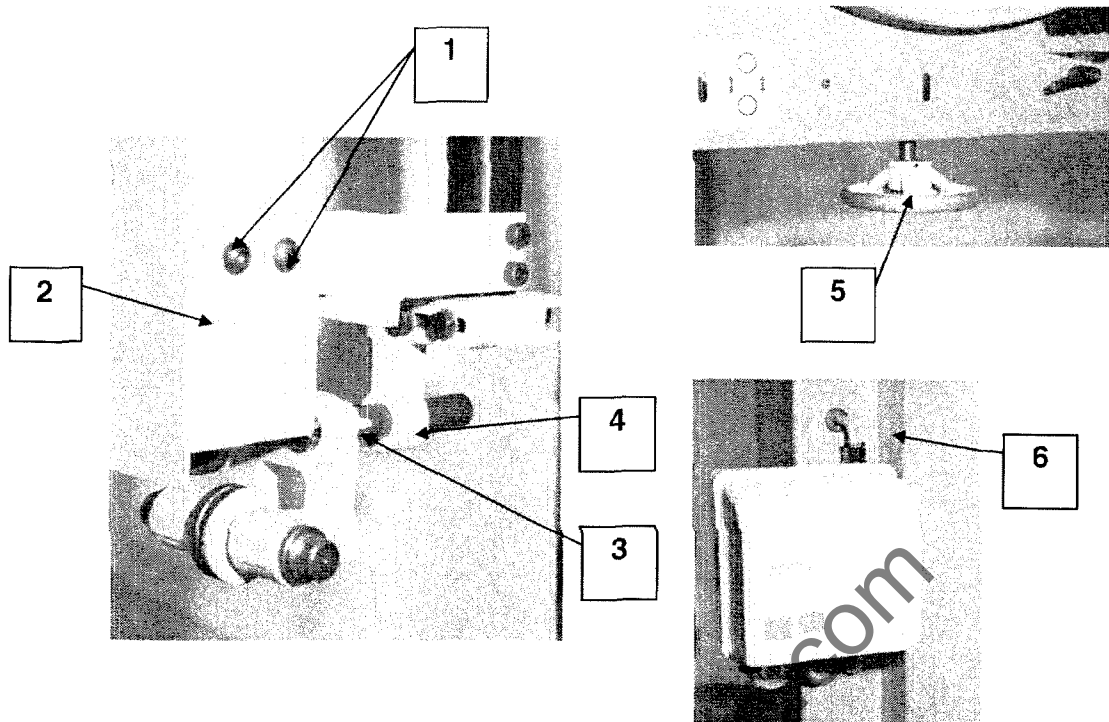

Figure 5.2

*Note:*

*The blade cutting teeth should be pointing down at the cutting point.*

- 6) Using handwheel (5) raise the top wheel until the blade is held on the wheels.
- 7) Continue procedure by tracking the saw blade as described in Section 5.3.

### 5.3 Tracking a Saw Blade (Figure 5.3)

Saw blades can have different operating characteristics on a bandsaw owing to the quality of ribbon from which the blade is made, the blade jointing and the tension of the blade ribbon. These factors are compensated for on the bandsaw having a tilting adjustment on the top wheel.

This tracking adjustment ensures that the saw blade passes in a straight line between the top and bottom wheels with no 'snaking' movement, so preventing unwanted contact between the saw blade and the machine guide rollers.

**WARNING:**

**ENSURE THAT THE MACHINE IS ELECTRICALLY ISOLATED BEFORE PROCEEDING.**

- 1) Rotate the top wheel clockwise slowly by hand and check that the blade is central on the wheels.
- 2) If necessary, to centralise, slacken hand lock nut (1) and rotate handwheel (2) until the blade is tracking central to both wheels.

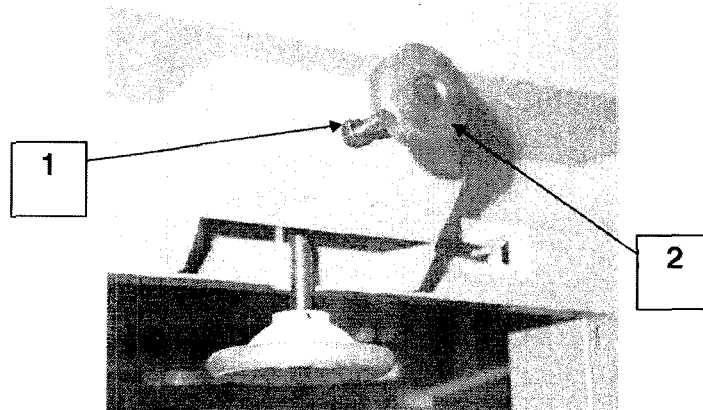

Figure 5.3

- 3) Tighten lock nut (1).
- 4) Close the top and bottom doors.

#### 5.4 Tensioning a Saw Blade (using Tensioning Scale) (Figure 5.4)

**WARNING:**

**ENSURE THAT THE MACHINE IS ELECTRICALLY ISOLATED BEFORE PROCEEDING.**

- 1) Open the machine top door.
- 2) Rotate handwheel (1) until pointer on scale (2) points to the width of the saw blade fitted.

The blade is now tensioned correctly.

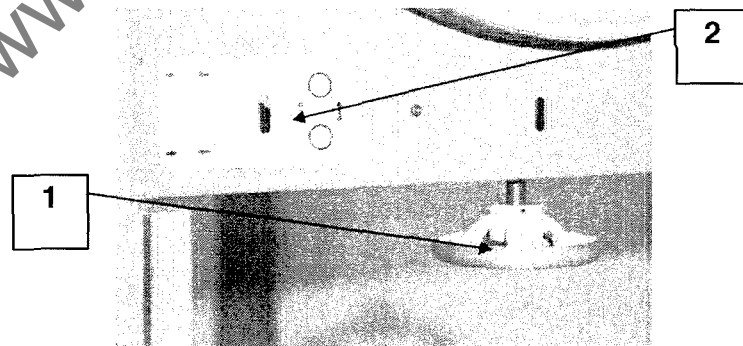

Figure 5.4

#### 5.5 Setting the Top Saw Guide Unit (Figure 5.5)

The top saw guide unit is located above the table and is adjustable to provide the necessary support to the saw blade.

**WARNING:**

**ENSURE THAT THE MACHINE IS ELECTRICALLY ISOLATED BEFORE PROCEEDING.**

- 1 Slacken guide roller locknuts (1) and wind the side roller adjusters (2) counterclockwise until the rollers are approximately 2-3mm apart.

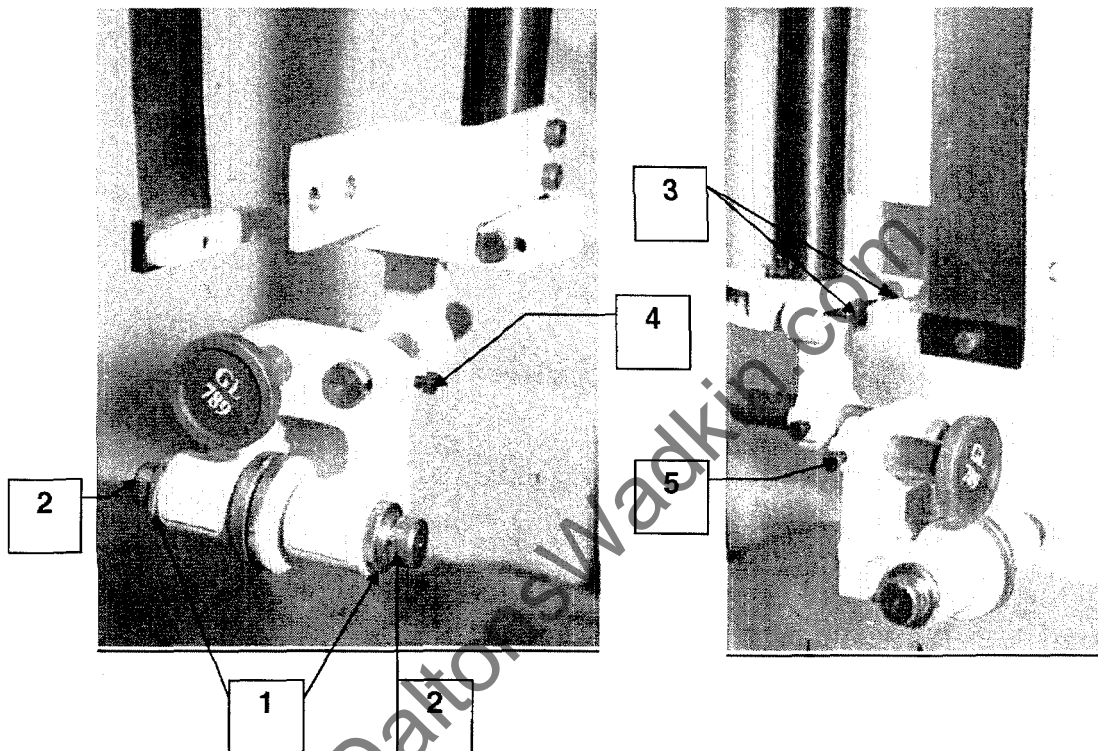

Figure 5.5

- 2) Slacken bolts (3) and centralise the saw blade between the side rollers and ensure it is vertical. Tighten bolts (3).
- 3) Check that the throat of the blade is just in front of the face of the rear roller.
- 4) If the rear roller needs positioning, slacken bolt (4) and move the roller housing to locate the rear roller as required; tighten bolt (4).
- 5) Wind the side roller adjusters together until they **just touch** the saw blade; tighten locknuts (1).

Turn the top wheel and ensure that the movement of the blade does **not** rotate the side rollers; if so, reset their positions.

- 6) Slacken thumbscrew (5) and move the rear roller just clear of the back of the saw blade; tighten thumbscrew (5).
- 7) Refit the top saw guard ((2) Figure 5.2).

## 5.6 Adjusting the Height of the Top Saw Guide Unit (Figure 5.6)

**WARNING:**

**ENSURE THAT THE MACHINE IS ELECTRICALLY ISOLATED BEFORE PROCEEDING.**

- 1) Hold the top saw guide assembly (1) firmly and slacken clamp (2).
- 2) Lower/raise the assembly to required level and relock clamp (2).

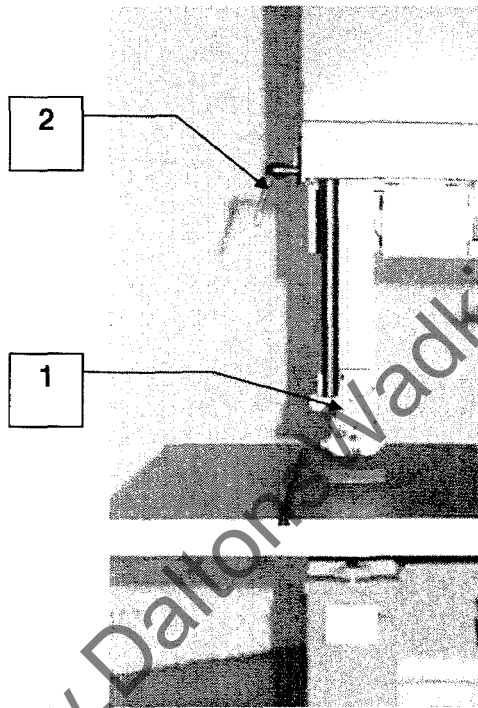

Figure 5.6

## 5.7 Setting the Bottom Saw Guide Unit

This procedure is similar to that described for the top saw guide unit in Section 5.5.

## 5.8 Setting the Table Cant Adjustment (Figure 5.8)

The table can be canted longitudinally.

**WARNING:**

**ENSURE THAT THE MACHINE IS ELECTRICALLY ISOLATED BEFORE PROCEEDING.**

- 1) Support the weight of the table.
- 2) Slacken nut (1) and cant table to required angle as indicated on table scale (2).
- 3) Tighten nut (1).

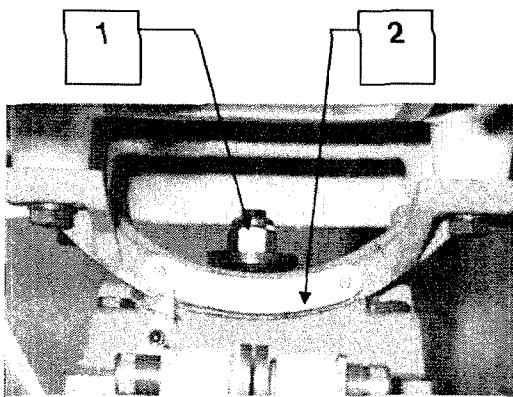

Figure 5.8

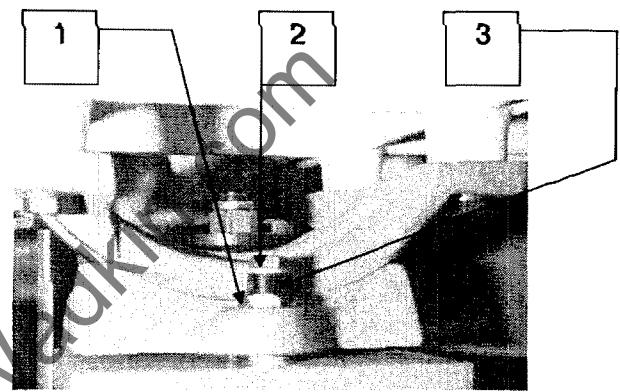

Figure 5.9

## 5.9 Setting the Table/Saw Blade Squareness (Figure 5.9)

The table is set square to the saw blade before despatch from the works. Any adjustment necessary on site should be carried out as described below.

**WARNING:**

**ENSURE THAT THE MACHINE IS ELECTRICALLY ISOLATED BEFORE PROCEEDING.**

- 1) Raise the top saw guide unit clear of the table (see Section 5.6).
- 2) Ensure that the saw blade is tracking correctly (see Section 5.3).
- 3) Slacken locknut (1) and bolt (2). Insert an Allen key into the key slot in screw (3).
- 4) Using a set square as reference, turn the Allen key to rotate screw (3) until the table is square to the saw blade.
- 5) Tighten bolt (2) and nut (1).
- 6) Reposition the top saw guide unit.



## 5.10 Setting the Rip Fence (Figure 5.10)

The rip fence is used to set the width of cut of the bandsaw and can be mounted inside or outside the saw blade.

**WARNING:**

**ENSURE THAT THE MACHINE IS ELECTRICALLY ISOLATED BEFORE PROCEEDING.**

- 1) Locate the rip fence on the slide bar (1) spanning the length of the bandsaw.
- 2) Position the fence and lock with locking control (2).

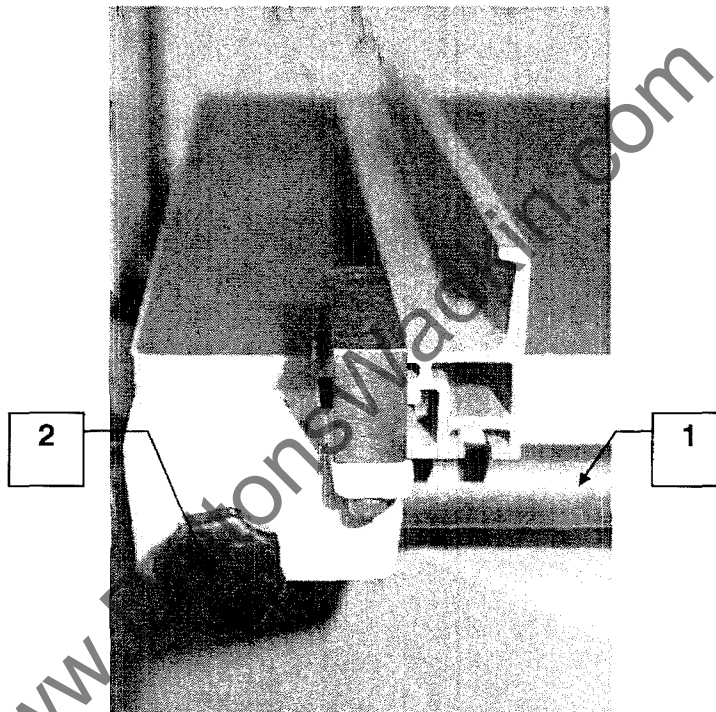

Figure 5.10

## 6 OPERATION

---

### 6.1 General

This Section gives a typical operating sequence for a bandsaw machine using the controls described in Section 4 and the basic set-up procedures described in Section 5.

It should be noted that the sequence is typical only - the use of machine controls in conjunction with the setting-up procedures vary depending upon the features of the machine and also the process it is to undertake.

Users are expected to establish operating procedures which comply with local requirements and practices.

#### 6.1.1 Pre-operation Checks

Undertake all the pre-operation checks detailed in Section 4.1.1.

#### 6.1.2 Setting Controls and Adjustments

- 1) Close the machine electrical supply Isolator (remote from the machine).
- 2) Check that the top and bottom saw guards are fitted correctly and that the dust extraction equipment is connected and working.
- 3) Press the Start pushbutton on the controller.
- 4) The machine is now ready for production operation.

## 7 MAINTENANCE

---

### 7.1 General

This Section covers scheduled and unscheduled maintenance of the machine.

Scheduled maintenance comprises the maintenance necessary, at regular intervals, to maintain the machine in good working order.

Unscheduled maintenance is that work necessary to replace or repair worn, unserviceable or damaged components.

Scheduled maintenance can normally be undertaken by a competent, but not necessarily specialised person (operator); unscheduled maintenance must be undertaken by an engineer experienced on this type of equipment and equipped with special tools.

### 7.2 Scheduled Maintenance

The following schedule, when undertaken, should be recorded in a maintenance log.

Equipment required:

- 1 Standard tool kit.
- 2 Lubricants as detailed.

#### 7.2.1 Daily

**WARNING:**

**ENSURE THAT THE MACHINE IS ELECTRICALLY ISOLATED BEFORE UNDERTAKING ANY OF THE FOLLOWING TASKS.**

- 1) Carry out a visual check of the machine and the surrounding area to check for any obvious signs of damage, wear, etc., and to ensure safe working conditions exist.
- 2) Open the top and bottom doors and clean wood refuse from the wheels to prevent an accumulation which might cause the line of the saw blade to move off centre.
- 3) Clean the table with a brush or soft cloth.

### 7.2.2 Weekly (Figure 7.2.2)

- 1) Open the top and bottom doors and clean wood refuse from inside the machine.
- 2) Clean wood refuse from the top and bottom wheel brushes (1).

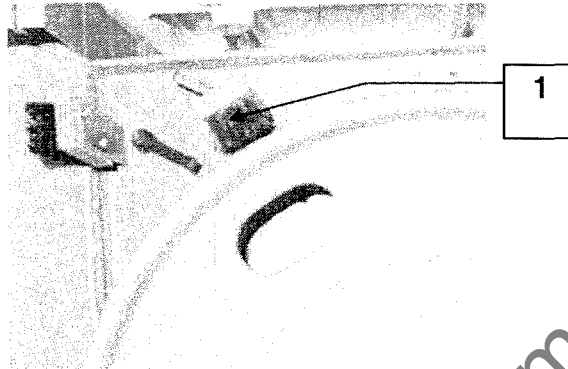

Figure 7.2.2

- 3) Lubricate the machine (with lithium grease) at the points shown on the Foundation Plan.

### 7.2.3 Monthly

- 1) Check the electric motor drive belt tension. (If re-tensioning is necessary, refer to Section 7.3).
- 2) Remove the cowl from the electric motor and clean the motor fan; check for signs of overheating or excessive end-float of the motor.

## 7.3 Unscheduled Maintenance

Unscheduled maintenance is that work necessary to replace or repair worn, unserviceable or damaged components.

Generally, following any procedure covered in this Section, a set-up procedure will need to be undertaken (see Section 5) before the machine is put into service.

This Section covers checks and replacement procedures in isolation. There will be times, depending upon the work to be undertaken, where many of these procedures will be carried out sequentially.

Equipment required:

- 1 Standard tool kit.
- 2 Replacement parts as necessary.

**WARNING:**  
ENSURE THAT THE MACHINE IS ELECTRICALLY ISOLATED BEFORE UNDERTAKING ANY OF THE FOLLOWING TASKS.

ENSURE THAT PROPER PROTECTIVE CLOTHING IS USED THROUGHOUT THESE TASKS.

### 7.3.1 Re-tension Electric Motor Drive Belt (Figure 7.3.1)

Incorrect tension is a prime cause of premature belt failure.

Under-tension can result in incorrect drive speed owing to belt slip, while over tension can cause overheating and extensive damage to motor bearings.

When re-tensioning is necessary, carry out the following procedure.

**WARNING:**  
ENSURE THAT THE MACHINE IS ELECTRICALLY ISOLATED BEFORE PROCEEDING.

- 1) Slacken the two motor mounting bolts (1) located behind the bottom wheel.
- 2) Slacken lock nut (2).
- 3) Turn nut (3) until slackness in the belt is eliminated. (Belt tension is felt by putting hand behind the bottom wheel). Turn nut (3) until approximately 10-12mm of play is felt in belt tension.
- 4) Lock nut (2).
- 5) Lock bolts (1).

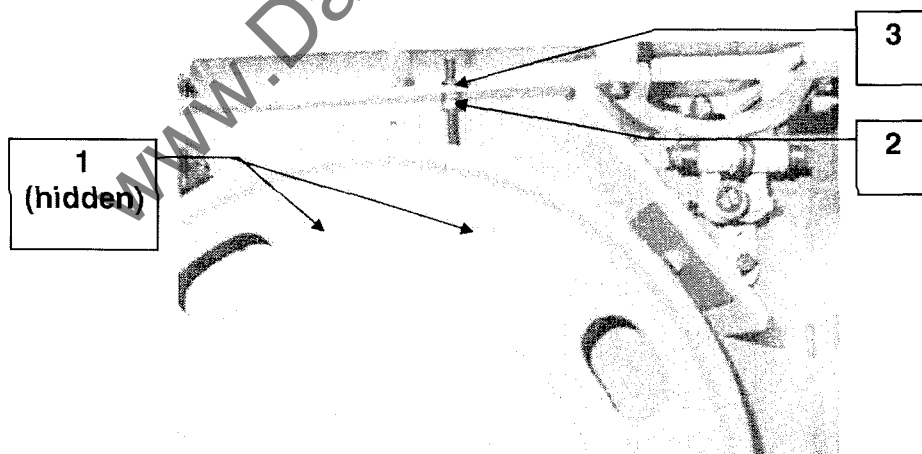

Figure 7.3.1

### 7.3.2 Remove Top and Bottom Wheels

#### Remove/Refit Top Wheel (Figure 7.3.2A)

**WARNING:**

**ENSURE THAT THE MACHINE IS ELECTRICALLY ISOLATED BEFORE PROCEEDING.**

- 1) Open the top and bottom doors.
- 2) Remove the saw blade by carrying out the reverse procedure in Section 5.2.
- 3) Slacken bolt (1) and withdraw the bolt and washer (2) from the wheel spindle.
- 4) Support the weight of the wheel, and withdraw it from the spindle.
- 5) Close the doors.
- 6) When refitting the top wheel reverse the above procedure and then fit the saw blade as described in Section 5.2.

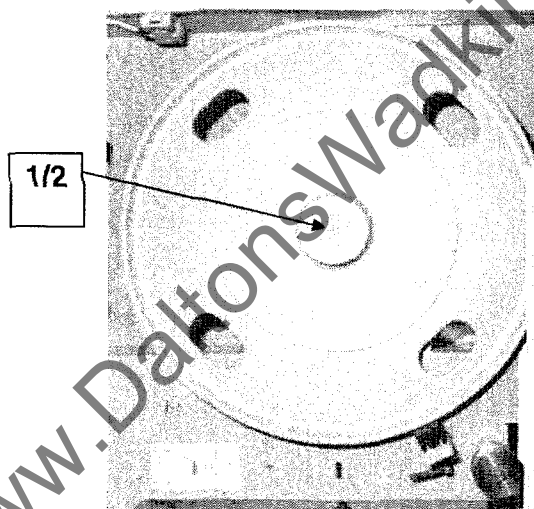

Figure 7.3.2A

#### Remove Bottom Wheel (Figure 7.3.2B)

**WARNING:**

**ENSURE THAT THE MACHINE IS ELECTRICALLY ISOLATED BEFORE PROCEEDING**

- 1) Open the top and bottom doors.
- 2) Remove the saw blade by carrying out the reverse procedure in Section 5.2.
- 3) Slacken the electric motor drive belt tension as described in Section 7.3.1.

- 4) Slacken bolt (1) and withdraw the bolt and washer (2) from the wheel spindle.
- 5) Support the weight of the wheel and release the drive belt from the pulleys; withdraw the wheel it from the spindle.
- 6) Close the doors.
- 7) When refitting the bottom wheel reverse the above procedure and then re-tension the saw blade as described in Section 7.3.1 and fit the saw blade as described in Section 5.2.

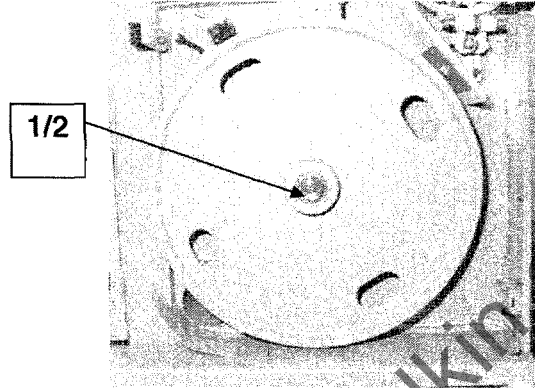

Figure 7.3.2B

## 8 GENERAL INFORMATION

---

### 8.1 Advice on Cutting

Always plan the direction/path of cutting before beginning work.

Ensure that chosen path takes in account positions of obstructions (machine trunk, etc.) which might be encountered.

When a choice of starting points is offered, choose to carry out short cuts first. ('Back tracking' out of a short cut is far easier than out of a longer cut).

If not fitted to the bandsaw, the use of a sawdust deflector fitted as close as possible to the saw blade (without actually touching) and to the dust extraction outlet, will help in reducing the accumulation of debris/dust in the machine base.

### 8.2 Bandsaw Blades

A properly-sharpened bandsaw blade gives clean, accurate cutting. Always set the teeth before sharpening.

#### Setting

Setting bandsaw teeth is carried out by bending the teeth alternately out of line of the blade. This presents alternate pairs of teeth, wider than the thickness of the ribbon, and prevents the ribbon from rubbing in the wood causing overheating. There are two ways of setting bandsaw teeth - hand setting and machine setting

When hand setting, the points of the teeth are set using a 'plier type' hand setting tool; the teeth are generally set so that the tooth point on either side is 0.3mm of centre of the ribbon line. Set is applied in opposite directions for each alternate tooth.

After hand setting has been employed it is sometimes necessary to stone teeth to ensure that all teeth carry out a cut. An ordinary fine grit stone is suitable for this work, and the back runner guides are brought forward until they are in contact with the back of the saw blade.

The blade is then run and the stone is carefully applied to the teeth on both sides of the blade. After sharpening, the teeth should be inspected. Those teeth which have not been marked with the stone should now be filed **only lightly**. Those teeth which have been stoned should be filed in the normal manner to remove the flat caused by the stone.

Bandsaw blades, on average, need stoning approximately once in every six sharpenings.



Machine setting is achieved with a setting attachment which can be fitted the bandsaw. Information on this equipment can be obtained from Wadkin.

### **Sharpening**

Sharpening is normally undertaken using a triangular section file. There are two ways of sharpening a bandsaw blade - hand sharpening and machine sharpening.

When hand sharpening, a vice should be used to retain the blade.

With each stroke of the file, the face of one tooth and the rear of the adjacent tooth are filed. One stroke is normally sufficient to sharpen a tooth. A light stroke should be used in order to avoid causing burrs on the blade.

While the angle of the gullet is maintained at 60° by the file, the angle of the hook on the tooth depends on the position of the file. Generally, a 5° angle of the hook is acceptable. The angle may need to change depending upon the hardness of the wood to be processed.

Sharpening should always be carried out square across the face of the tooth, **not** on the bevel, this could make the saw vibrate violently and lead to breakage.

A file with rounded corners and triangular section should be used, and it is important that the gullet of each tooth be rounded to avoid cracking.

Saws should be sharpened at frequent intervals, cutting with a blade having blunt teeth must be avoided.

When reconditioning a saw blade, it is necessary to undertake setting of the teeth before beginning sharpening.

Machine sharpening can be achieved with a special automatic machine. Information on this equipment can be obtained from Wadkin.

### **Spares**

Spare bandsaw blades are available from Wadkin. These blades are cut to length, set and sharpened. Additionally, blades can be supplied in strip form for the user to make up.

Bandsaw blades available are:

C5	Standard	4165mm (164in)
	Hardened Teeth	4165mm (164in)
C7	Standard	5080mm (200in)
	Hardened Teeth	5080mm 200in)

Files for sharpening are also available in 150mm, 200mm and 250mm sizes. All files have rounded corners to produce the required gullet shape.

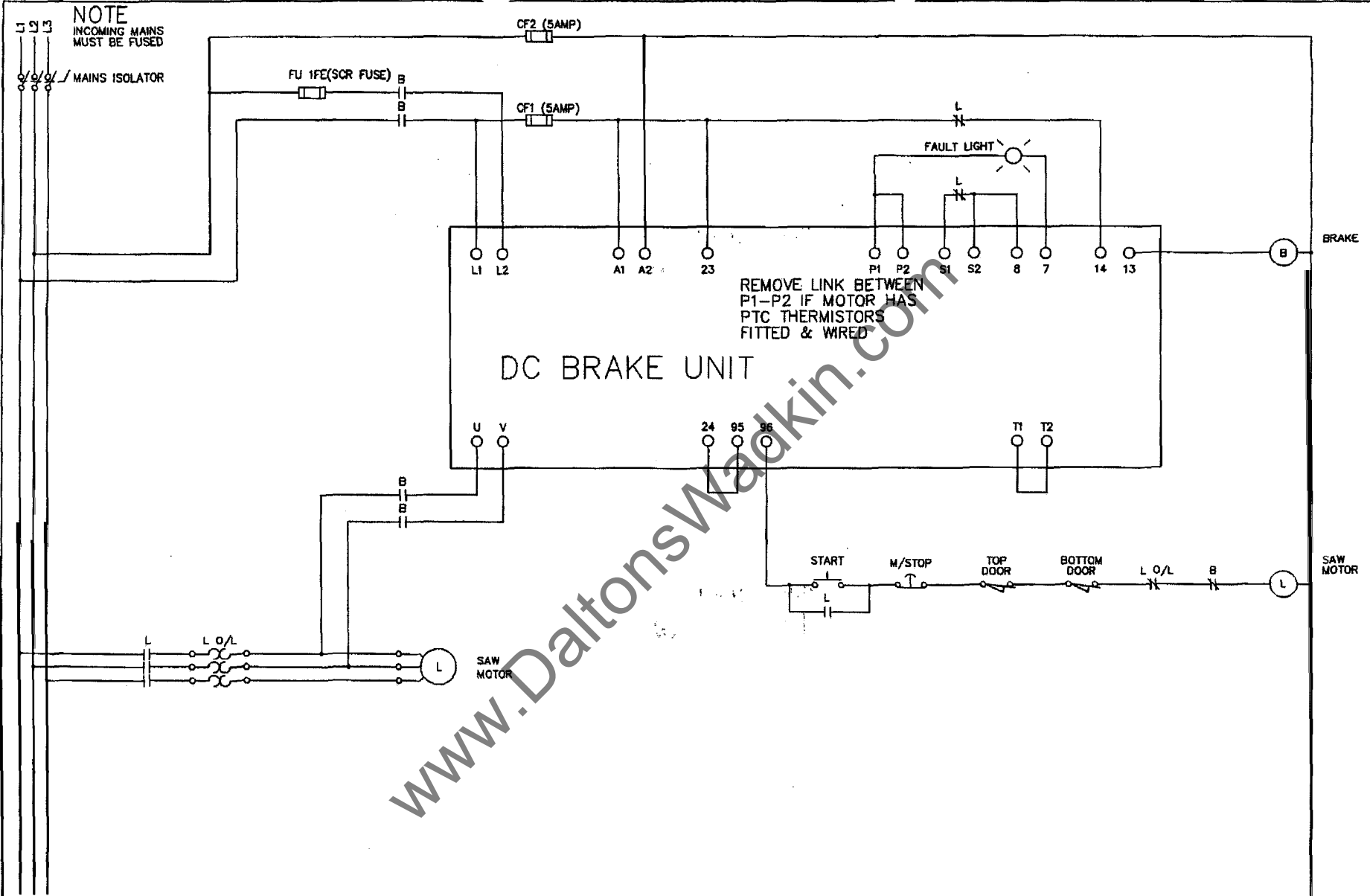

 LEICESTER WOODWORKING DIVISION	Date	Sig.	C	Date	Sig.	B	Date	Sig.	A	Description WITH <b>C5/C7 DC BRAKING</b>	Drawn K.MOBBS	Drawing No. <b>D7453</b> SHEET 01
							<b>02 FEB 2000</b>				Aprvd-R.PATEL	
											Date 02/02/00	
										CAD Location N:\ACAD\DR\ELECTDO\ELECSTD\ESTD4178	W.O. No	

