

**TEMPORARY
INSTRUCTION
MANUAL**

BMA

CHAIN OR CHISEL MORTISER

PLEASE INSERT SERIAL
NUMBER OF MACHINE

MODIFICATIONS ARE MADE TO THESE BOOKS FROM TIME TO TIME
AND IT IS IMPORTANT THEREFORE THAT ONLY THE BOOK SENT
WITH THE MACHINE SHOULD BE USED AS A WORKING MANUAL

B

INSTALLATION

Remove protective coating from all bright parts by applying a cloth soaked in paraffin, turpentine or other solvent.

FOUNDATION

See foundation plan for bolt positions and clearances required. When installing the machine, level the bed by packing under the feet. Foundation bolts are not supplied with the machine except by special order.

WIRING DETAILS

The motor and control gear have been wired in before despatch. All that is required is to connect the power supply to the starter. See foundation plan for wiring diagram.

1. Check that the voltage, phase and frequency correspond to those on the motor plate, also the correct coils and heaters are fitted to the starter.
2. It is important that the correct cable is used to give the correct voltage to the starter as running on low voltage will damage the motor.
3. Check the main line fuses are of the correct capacity. See lists below :
4. Connect the line leads to the appropriate terminals. See foundation plan for 3 phase supply.
5. Check all connections are sound.
6. Check the rotation of the motor for the correct direction. If this is incorrect for 3 phase supply, reverse any two of the line lead connections.

<u>VOLTAGE</u>	<u>PHASE</u>	<u>CYCLES</u>	<u>HP</u>	<u>SWG TINNED COPPER WIRE</u>	<u>FUSE RATING</u>
380	3	50	5	23	20
380/420	3	50	5	23	20
220	3	60	5	19	38
220	3	50	5	19	38
400/440	3	50	5	23	20
550	3	60	5	24	17
440	3	60	5	23	20

LUBRICATION

It is advisable to keep all bright parts covered with a thin film of oil to prevent rusting.

TYPE OF OIL RECOMMENDED POWER EM 125

All bearings used on the standard machine are of the sealed for life type and require no further lubrication.

IF OSCILLATING HEAD UNIT IS FITTED :-

TYPE OF GREASE RECOMMENDED SHELL ALVANIA 3

NOTE : Ensure that oiler on handlever pivot is topped up at all times. See foundation plan for lubrication points.

HANDLEVER.

The handlever to the right of the machine is used to control the movement of the head. The handlever is provided with dual adjustment. Firstly to obtain the correct leverage, loosen the square head bolt fitted to handlever boss and slide lever through the boss until the

correct leverage is obtained. When set relock hexagon head bolt.

Secondly unnecessary movement of the head after the chisel has cleared the work, can be eliminated by releasing the plastic handwheel fitted to handlever clutch and adjusting clutch to the required position. Finally secure the clutch by tightening the plastic handwheel.

A stop is provided to the handlever which allows the handlever to return to one position only. This in turn restricts the movement of the head depending on the position of the clutch.

COUNTERBALANCE

The mortising head is counterbalanced by means of a spring connected by a chain to a cam on the handlever shaft. The tension of this spring is set for normal counterbalancing at the works but may be increased or reduced by loosening two locknuts under rear of machine then adjusting counterbalance as required by means of the hexagon head bolt on the extreme bottom of the assembly. When set relock two hexagon head locknuts.

DEPTH STOP ASSEMBLY

A stop to control the travel of the head is fitted to the left hand side of the head stock. Also incorporated on the stop bar is a haunching stop.

To control the travel of the head loosen square head screw on stop collar "A" in Fig. 1.; Move head to highest position required then slide stop collar "A" against boss "B". Relock square head screw.

The head can also be held in any position independently of the stop collar by means of thumbscrew "C".

To set for haunching, loosen square head screw on haunching stop "D" and position stop for maximum depth of mortise required. Relock square head screw.

With haunch lever "E" in open position (i.e. allowing haunch stop bar "F" to pass through hole in boss of stop "D" when head is in maximum down position) move head down until boss "B" contacts haunching stop "D". Loosen square head screw "G". Set haunch stop bar "F" at distance through hole in stop "D" for depth of haunch required. Relock square head screw "G".

When mortising, haunch lever should be in open position and when haunching, should be in closed position.

WORK CRAMP

The work cramp has 2 positions on the machine table allowing a maximum width of timber of 9" (230mm) between the cramp face and rear of table.

The cramp face is drilled to receive a wooden pad to prevent possible marking of the workpiece. An adjustable handlever controls the cramp pressure.

TABLE CONTROLS

The table has both longitudinal and lateral movements.

The longitudinal movement is controlled by large diameter handwheel at front of machine and has a maximum movement of 24" (610mm). The table has positive stops in the side which can be set to control the length of mortise to be cut.

Lateral movement of the table is controlled by small diameter handwheel at front of machine. The table can be locked in position laterally by means of ball lever screw situated on right hand lateral slide. Maximum lateral movement of 6" (150mm) can be obtained.

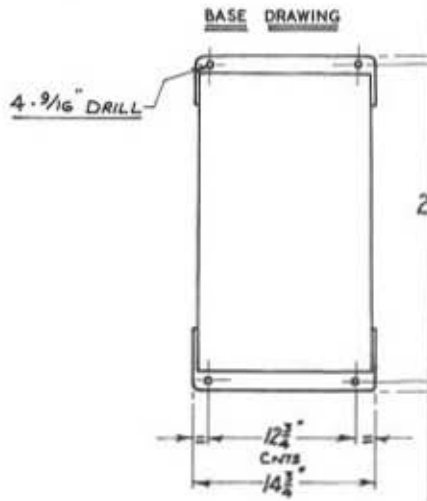
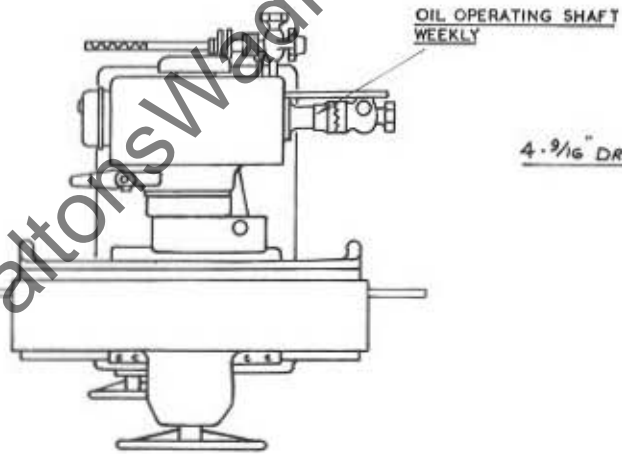
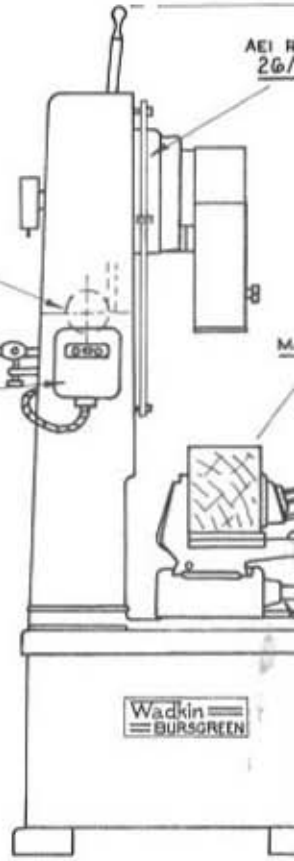
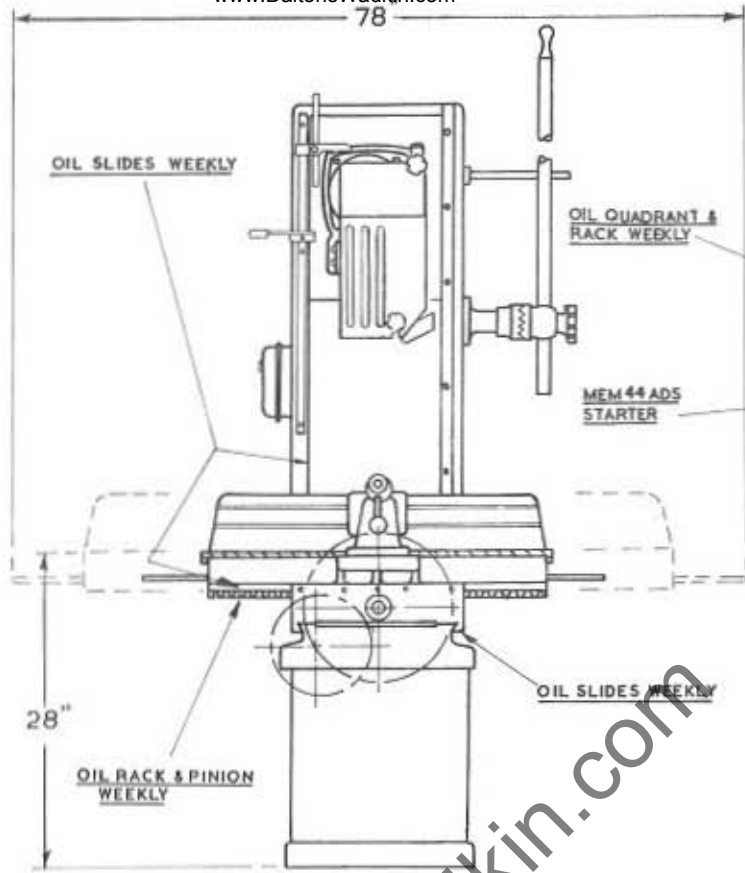

www.DaltonsWadkin.com

SPECIFICATION

WILL TAKE TIMBER UP TO	12' x 9"	300 x 230 M.M.
MAX. SIZE OF MORTISE USING CHAIN	1 1/2" x 3" x 6" DEEP	19 x 75 x 150 M.M.
MAX. SIZE OF CHISEL USED IN HARDWOOD	3/4" SQUARE	19 M.M.
MAX. SIZE OF CHISEL USED IN SOFTWOOD	1" SQUARE	25 M.M.
MAX. SIZE OF MORTISE CUT WITH OSC. UNIT.	5/8" x 2 3/4" DEEP	16 x 70 M.M.
HORSEPOWER OF MOTOR	5	5
SPEED OF MOTOR 50 CYCLES	3000 R.P.M.	3000 R.P.M.
60 CYCLES	3600 R.P.M.	3600 R.P.M.
SIZE OF TABLE	28 x 8"	710 x 200 M.M.
LONGITUDINAL MOVEMENT OF TABLE	24"	610 M.M.
LATERAL MOVEMENT OF TABLE	6"	150 M.M.
HEIGHT OF TABLE	28"	710 M.M.
APPROXIMATE FLOOR SPACE (WITH MAX MOVEMENTS)	51' x 42"	1300 x 1710 M.M.
APPROXIMATE NET WEIGHT	1000 lb	450 kg
APPROXIMATE GROSS WEIGHT	1250 lb	570 kg
APPROXIMATE SHIPPING DIMENSIONS	65 cu. ft.	1.84 m. ³

BEARINGS USED

F.B.C. 6206. F.F.	MOTOR
SKF. 6205. 2RS.	CHISEL HEAD.
SKF. 6205. 2RS.	OSCILATING HEAD
SKF. 6006. 2RS.	" " " "
SKF. 6202. 2RS.	" " " "

NOTE:—

OIL ALL MOVING PARTS WEEKLY.
TYPE OF OIL. — POWER. EM,125.

WHEN INSTALLING LEVEL TABLE BY PACKING UNDER BASE.

WIRING DIAGRAM

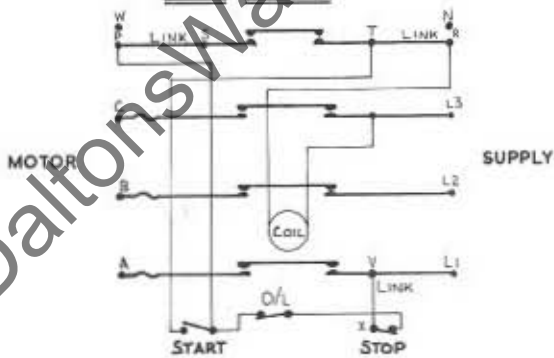

TITLE CHAIN OR CHISEL MORTISING M ²				BURSGREEN (DURHAM) LTD. FENCE HOUSES CO DURHAM.	
FOUNDATION DRAWING.	TYPE BMA.	MOD. NOTES	SCALE 1:8	DATE:—	DRG. NO.
				10-12-69	1061/FD

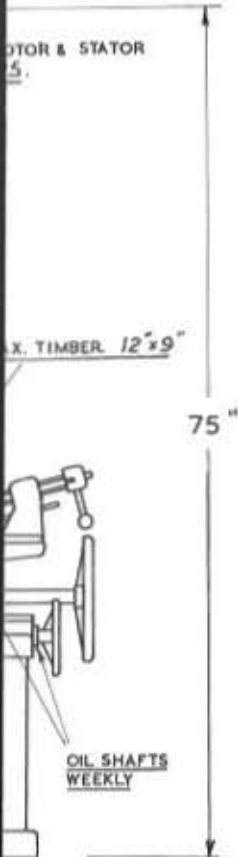

Mortising, How to Set Chisel.

The lips or spurs of the bit should not be allowed to touch the cutting edge of the chisel but should be set $1/32"$ (.8mm) below the chisel points, as shown in Fig. 2 so that the bit cuts before the chisel.

The bit is held in the machine spindle by means of self centring chuck "A" in Fig. 3.

The chisel is held in a special bracket below the machine spindle and is locked in position by means of the hexagon nut "B" in Fig. 3. The bore of the bracket is $1.3/8"$ (35mm) and a pair of bushes is supplied so that all sizes of chisel can be used up to a maximum size of 1" (25.4mm) square.

To set the chisel correctly, select the bush required and fit bush to chisel, push the chisel complete with bush into the chisel holder bracket until the shoulder comes into contact with the chisel bracket. The chisel should also be positioned square to the rear of the table. When correctly positioned, lock securely in position by means of the hexagon nut "B".

Position the bit so that the lips protrude $1/32"$ (.8mm) below the chisel points and lock the bit tightly in position. Care should be taken to ensure that the bit is securely locked so that it cannot be forced against the cutting edge of the chisel resulting in a fractured tool.

Do not jerk the tool into the work but give steady pressure. Withdraw the tool occasionally from the work to allow the bit to clear itself of chips.

The maximum chisel which can be used in soft wood is 1" (25.4mm) square and $3/4"$ (19mm) square in hardwood.

Mortising, How to Set Chain

The mortise chain must revolve so that the cutting edges descend into the work as in Fig. 4. Use only the sprocket wheel and guide bar for the size of the mortise required. Each is clearly marked. Keep the chain adjusted so that it can be pulled away from the bar $1/4"$ as in Fig. 4. Screw "A" above the bar "B" is to adjust the chain to the correct tension and to take the thrust of the bar. The chain when new should run idle for a few minutes and be re-adjusted before being put to use. Lubricate about every half hour. See note below.

Do not force chain into wood, but feed smoothly. Do not traverse table while the chain is in the mortise. To cut a longer or wider mortise than the chain allows, bring chain out of cut and traverse table before making second cut. Although the mortise chains are supplied suitable for general work, in hard and soft woods it is advisable when wet oak is used to grind them to a special angle.

The guide bar "B" in Fig. 5 is held in position by guide block "C" in Fig. 5 and the chain sprocket "D" is attached to the main spindle and held tight by the nut "E". The correct working position for the bar "B" is when the fixing bolt is in the centre of the slot and the mortise chain tensioned in the manner described above.

Note :-

The efficient lubrication of the mortise chains during operation has always been a difficulty and therefore we have introduced a greasing arrangement which it is considered will prolong the life of the chain. The improvement incorporates a grease nipple in the guide bar from which the lubricant is carried down the bar and into the bottom roller.

Should the mortise chain be in operation for a long period, it is essential to give one or two depressions of the grease gun every half hour. The exact period for lubricating must be decided by the operator. Do not allow the guide bar to become hot.

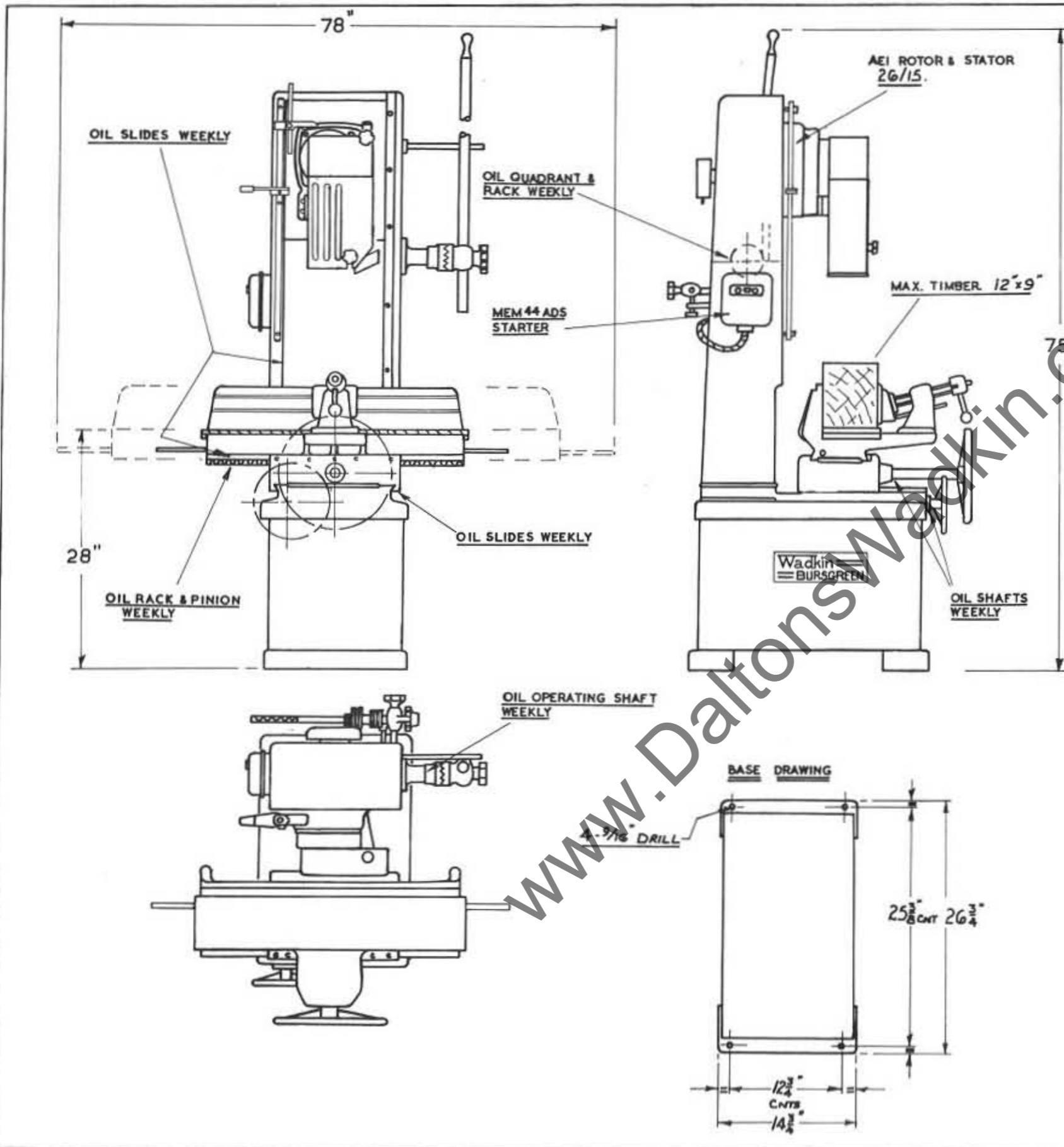

SPECIFICATION

WILL TAKE TIMBER UP TO.....	12' x 9"	300 x 230 mm.
MAX. SIZE OF MORTISE USING CHAIN.....	1 1/2 x 3 x 6" DEEP	19 x 75 x 150 mm.
MAX. SIZE OF CHISEL USED IN HARDWOOD.....	3/4" SQUARE	19 mm.
MAX. SIZE OF CHISEL USED IN SOFTWOOD.....	1" SQUARE	25 mm.
MAX. SIZE OF MORTISE CUT WITH OSC. UNIT.....	5/8 x 2 3/4" DEEP	16 x 70 mm.
HORSE POWER OF MOTOR.....	5	5
SPEED OF MOTOR 50 CYCLES.....	3000 R.P.M.	3000 R.P.M.
60 CYCLES.....	3600 R.P.M.	3600 R.P.M.
SIZE OF TABLE.....	28 x 8"	710 x 200 mm.
LONGITUDINAL MOVEMENT OF TABLE.....	24"	610 mm.
LATERAL MOVEMENT OF TABLE.....	6"	150 mm.
HEIGHT OF TABLE.....	28"	710 mm.
APPROXIMATE FLOOR SPACE (WITH MAX. MOVEMENTS).....	51 x 42"	1300 x 1710 mm.
APPROXIMATE NET WEIGHT.....	1000 lb.	450 kg.
APPROXIMATE GROSS WEIGHT.....	1250 lb.	570 kg.
APPROXIMATE SHIPPING DIMENSIONS.....	65 cu. ft.	1.84 m ³

BEARINGS USED

F.B.C. 6206. F.F.	MOTOR
SKF. 6205. 2RS.	CHISEL HEAD.
SKF. 6205. 2RS.	OSCILLATING HEAD
SKF. 6006. 2RS.	" " " "
SKF. 6202. 2RS.	" " " "

NOTE:-

OIL ALL MOVING PARTS WEEKLY.
TYPE OF OIL. — POWER. EM.125.

WHEN INSTALLING LEVEL TABLE BY PACKING UNDER BASE.

WIRING DIAGRAM

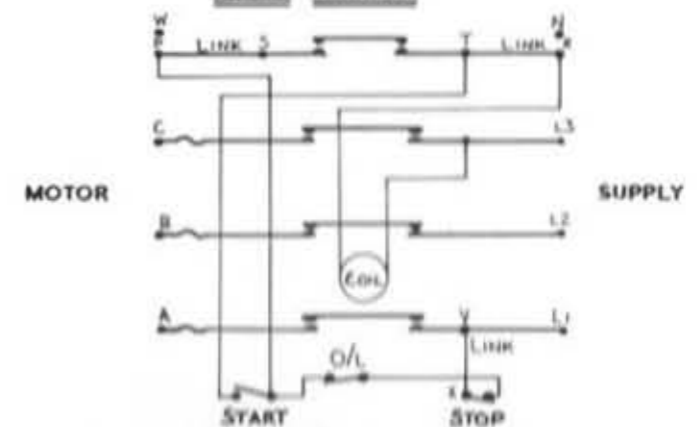

TITLE CHAIN OR CHISEL MORTISING M ²				BURSGREEN (DURHAM) LTD. FENCE HOUSES CO. DURHAM.	
FOUNDATION DRAWING.	TYPE BMA.	MOD. NOTES	SCALE 1:8	DATE 10-12-68	DRG. NO. 1061/FD
				DRG BY M.J.	