

www.DaltonsWadkin.com
HAND FEED PLANER TYPE 9" BFT

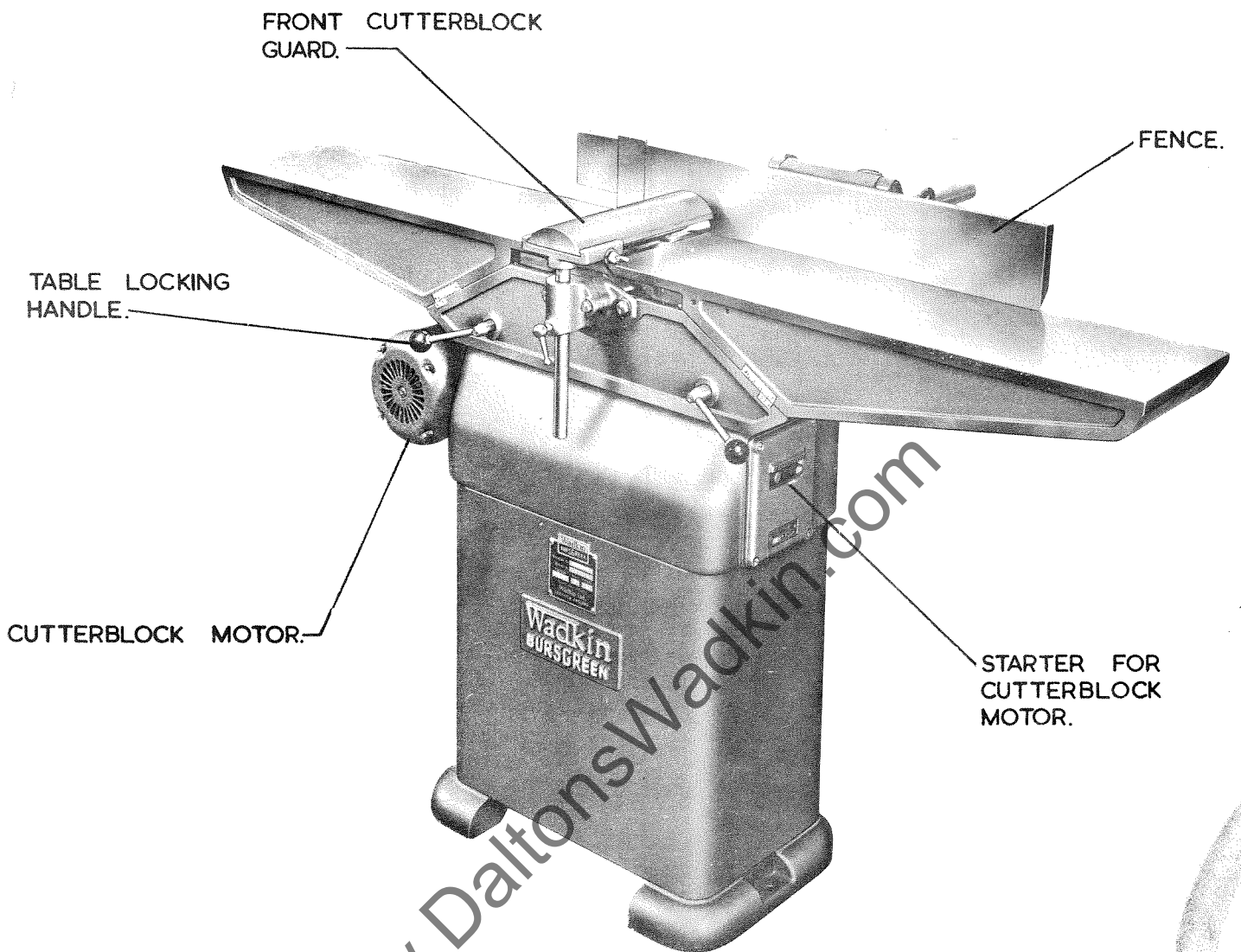

FIG. I.

S P E C I F I C A T I O N

Planing capacity...	9" wide	230 mm
Length of tables...	5' 0"	1525 mm
Speed of cutterblock in r.p.m	5000	5000
Cutting circle of cutterblock	3½"	90 mm
Fence:-		
Length...	30"	760 mm
Height...	4¼"	110 mm
Will cant to..	45°	45°
Will rebate to	½"	12 mm
Rise and fall of tables.	⅝"	16 mm
H.P. of driving motor...	2 (3 phase)	2 (1 phase)
Syn. speed of motor	3000 r.p.m, 50 cycles	3600 r.p.m, 60 cycles

	<u>FLOOR MACHINE</u>		<u>BENCH MACHINE</u>	
Height of table from floor...	34½"	875 mm	14⅞"	350 mm
Approx. floor space	5'x2'6"	1500x 750 mm	5'x2'6"	1500 x 750 mm
Approx. net weight	364lb	165 kg	325lb	150 kg
Approx. gross weight	540lb	245 kg	400lb	180 kg
Shipping dimensions.	27 cu.ft.	.75 cu.m	12½cu.ft.	.35 cu.m.
Rebate table (EXTRA)	12lb	5 kg	12lb	5 kg

INSTALLATION

Remove protective coating from bright parts by applying a cloth soaked in paraffin, turpentine or other solvent.

When the machine is cased for export the motor, belt guard, fence and front cutterblock guard are removed and packed individually. Remove and re-assemble as shown in Fig. 1.

See Fig. 5 for bolt positions and clearance required. When installing the machine, level the table by packing under the feet. Foundation bolts are not supplied with the machine except by special order.

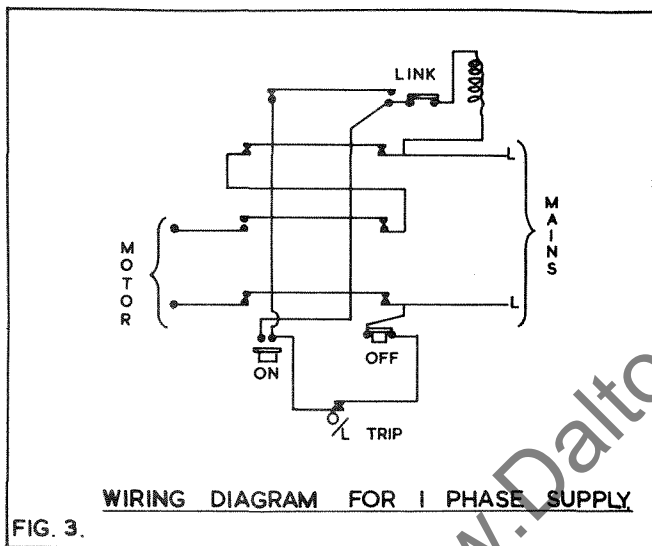
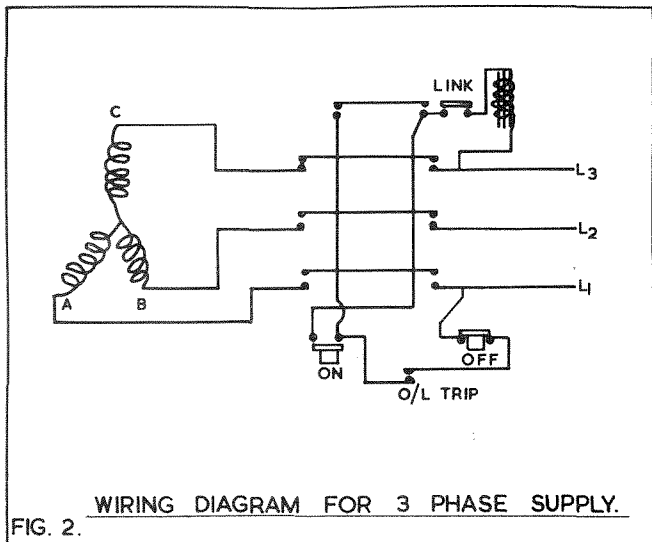

WIRING DETAILS

The motor and control gear have been wired in before despatch. All that is required is to connect the power supply to the starter.

Points to note when connecting to power supply:-

1. Check the voltage, phase and frequency correspond to those on the motor plate, also the correct coils and heaters are fitted to the starter.
2. It is important that the correct cable is used to give the correct voltage to the starter as running on low voltage will damage the motor.
3. Check the main line fuses are of the correct capacity. See list below.
4. Connect the line leads to the appropriate terminals. See Fig. 2 for three phase supply. See Fig. 3 for single phase supply.
5. Check all connections are sound.
6. Check the rotation of the motor for the correct direction. If this is incorrect on three phase supply reverse any two of the line lead connections.

VOLTAGE	PHASE	SWG. TINNED COPPER WIRE	AMPS
220	3	27	24
340/420	3	25	15
550	3	29	10
200/250	1	19	38

LUBRICATION

It is advisable to keep all bright parts covered with a thin film of oil to prevent rusting. The slideways should also be kept clear of chippings for ease of operation.

TYPE OF OIL RECOMMENDED
TYPE OF GREASE RECOMMENDED

POWER EM 125
SHELL ALVANIA

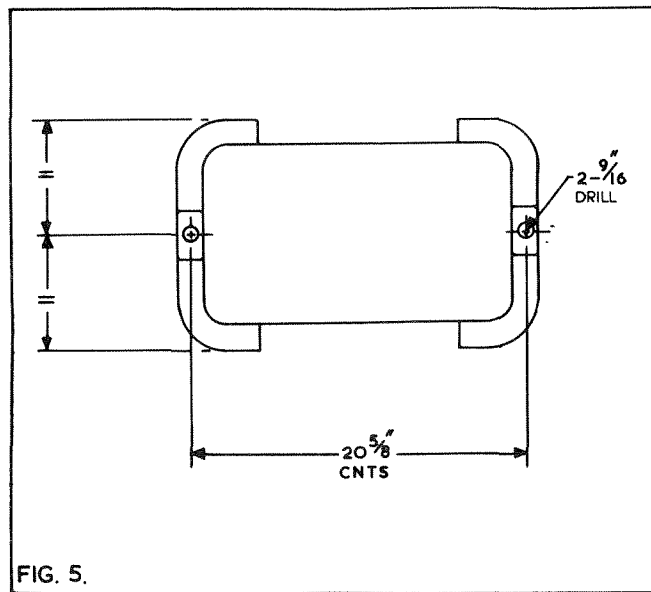
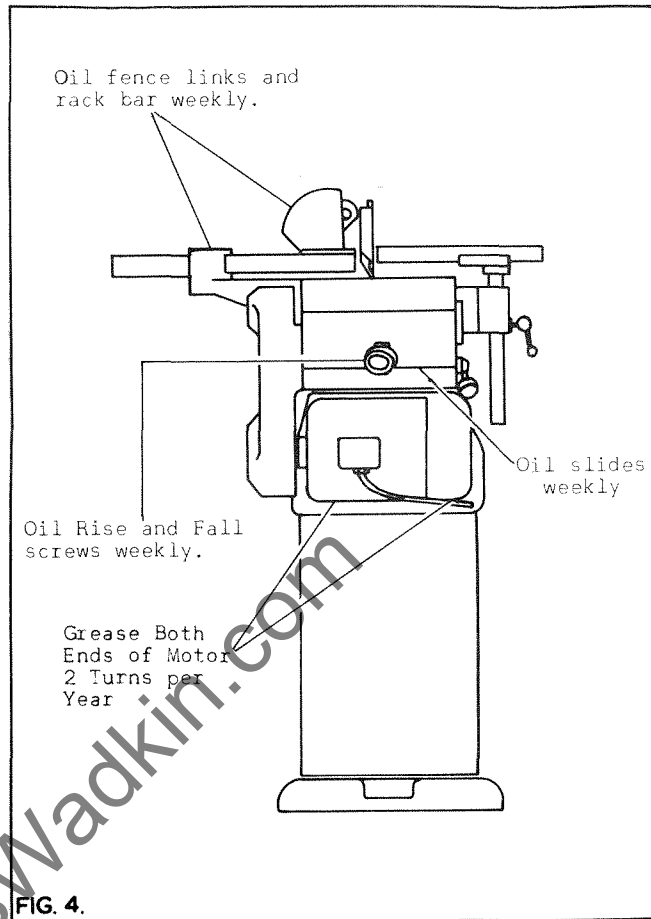

BELT TENSION

The drive is by means of 2 vee belts from a 2 HP motor mounted on a hinge bracket.

To check the belt tension, remove the belt guard at the rear of the machine.

The tensioning arrangement is shown in Fig. 6.

To re-tension the belts the undermentioned procedure should be followed:-

1. Adjust the nut A, until the spring is compressed to approximately 9/16" against the pull of the belts. This will ensure the correct belt tension is maintained.
2. Replace the belt guard. This should be in place at all times when the machine is running. To ensure trouble free running of the machine it is desirable to check the belt tension regularly.

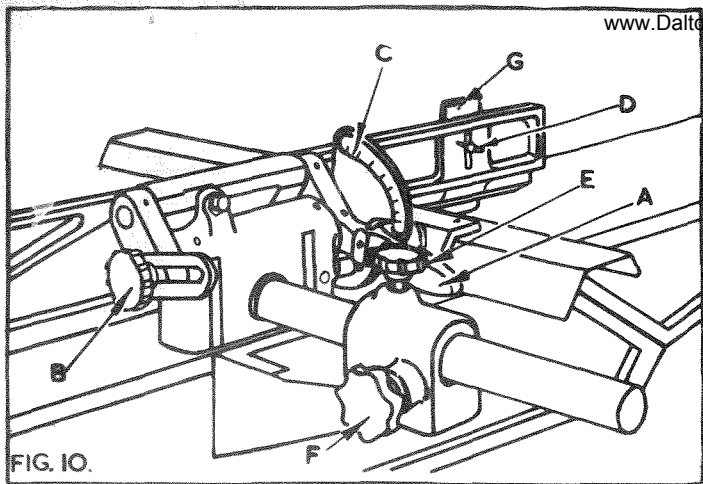

FENCE ADJUSTMENT

The fence cants by means of a single lever "A" in Fig. 10 to 45°. The angle to which the fence is canted is shown on a graduated scale "C".

To cant the fence to the required angle loosen the handwheel "B" and lift handle "A" until the required angle is shown on the graduated scale "C", then re-lock handwheel "B".

The fence front plate is fitted with an insert "G" which is over the rear planing table and is adjustable depending on the depth of cut which is being taken. To adjust the insert loosen the wing nut "D" and move the insert until it just touches the rear planing table then re-lock wing nut "D". The insert should be loosened at all times before lowering the front planing table.

The fence is also adjustable across the full width of the table by means of a rack and pinion. To adjust the fence across the table loosen the handwheel "E", and turn the handwheel "F" in the direction which the fence is required to move, until the required position is reached, then re-lock handwheel "E".

The fence should be locked in both positions at all times when the machine is in operation.

The fence has positive stops at 90° and 45°. These are both accurately set before despatch from the works.

To check the positive stops on the fence the undermentioned procedure should be followed:

1. Move the fence towards the rear of the table as shown in Fig. 11.
2. Check the 90° positive stops by means of a steel square as shown in Fig. 11. If adjustment is necessary, adjust the hexagon head bolts "A" until the fence is at right angles to the table when hard up against the stops and the handwheel "B", in Fig. 10, locked.
3. Check the 45° positive stop by means of an adjustable square. If adjustment is necessary, adjust the socket head grubscrew "B" until the fence is 45° to the table when hard up against the stop and the handwheel "B" in Fig. 10 locked.
4. If adjustment is necessary to the positive stops check that the graduated scale is still correct. This is secured to the support bar by means of a socket head grubscrew. This should be loosened and the scale accurately positioned to the pointer.

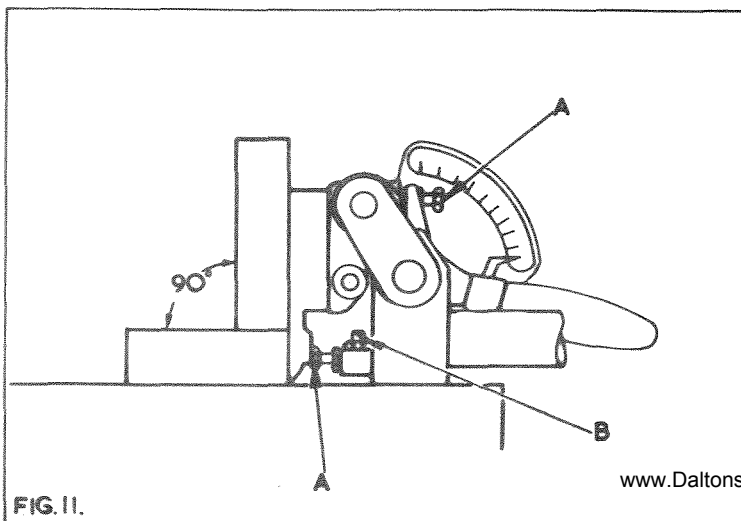

1. To obtain the best surface finish always check the direction of the grain, which should run with the cutter as shown in Fig. 12.
2. To obtain a perfectly flat surface especially with warped stock, always put maximum pressure on the back table at "A" in Fig. 13 and as little as possible on the front table at "B".
3. Greater pressure will be required when surfacing bad grained timber, otherwise chattering will take place resulting in coarse finish near each knot.
4. When planing four sides of timber, square turn the timber anti-clockwise after each cut, so that there will always be a machined face next to the fence as in Fig. 14. The fence locates accurately at 90°.

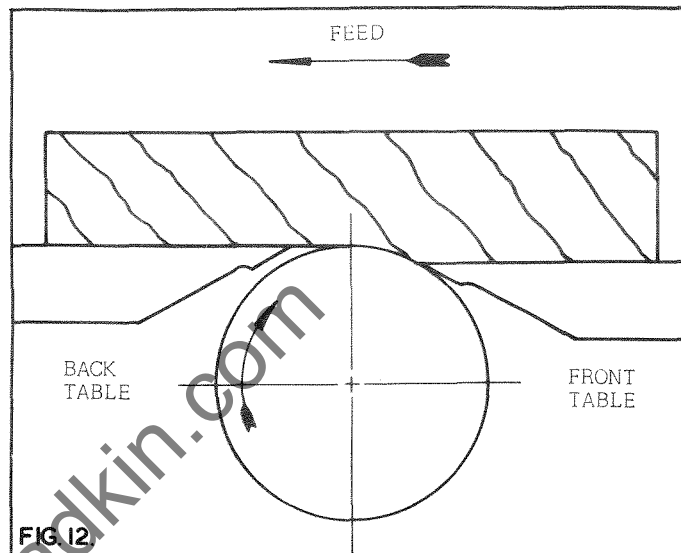

CORRECT RUN OF GRAIN.

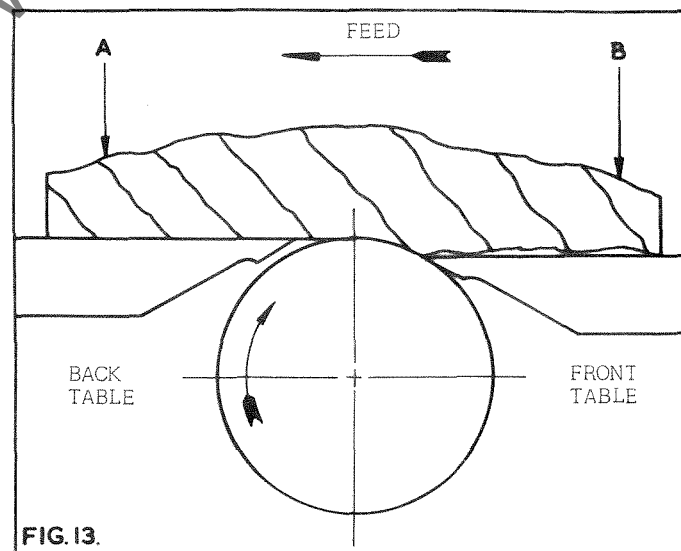

FEEDING WARPED TIMBER.

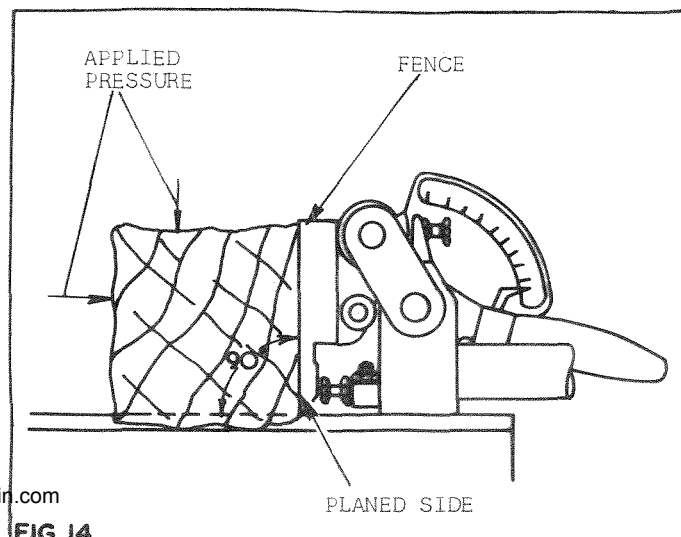

WORKING WITH FENCE.

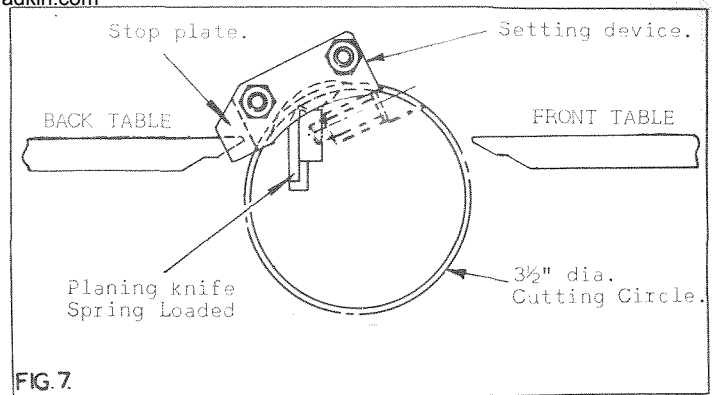
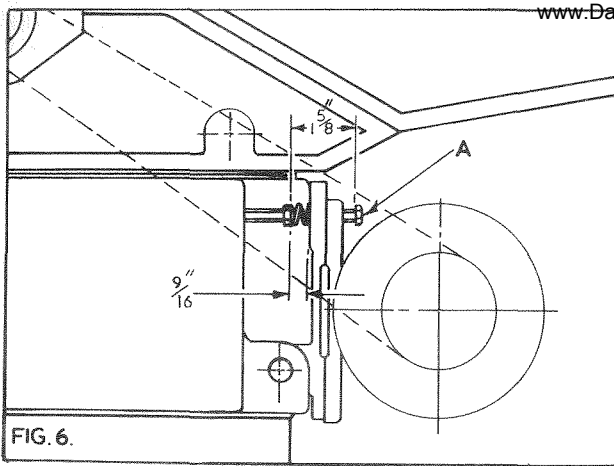

CUTTER SETTING

The knives are held in the cutterblock by a steel clamping bar secured with 4 - 1/2" whit. heat treated socket head screws. When the locking screws are released the cutters are ejected slightly by a small leaf spring. This is to facilitate easy cutter setting with the special gauge supplied. As the amount of cutter projection is vital to the correct operation of the machine it is most important that the actual gauge supplied with the machine should be used. Should any other method of cutter setting be employed the amount of cutter projection must be exactly the same as with that given by the setting gauge supplied and failure to observe this instruction will result in poor finish. To remove the cutters and re-set with "Bursgreen" cutter setting gauge proceed as follows:-

1. Move the fence to rear of the table and lower both planing tables to their lowest position.
2. Turn the cutterblock to approximately the position shown in Fig. 7 and slacken the securing screws until the knife is just free of the cutterblock. Care should be taken when loosening the last screw as the knives are spring loaded.

The knives can now be removed for grinding or replacing. When grinding it is most important that knives are ground dead straight and balanced in pairs or sets.

An efficient re-grinding service is available. Charges are moderate and service prompt. To avail yourself with this service, return cutters to:-

BURSGREEN (DURHAM) LIMITED
FENCE HOUSES, HOUGHTON-LE-SPRING, CO. DURHAM.

3. To re-set the knives, the cutterblock should be in approximately the position shown in Fig. 7. Place the knife in the slot making sure that all faces are clean and the clamping bar free from burrs. Press the knife into the cutterblock with the setting device in Fig. 7 until the four predominant pads rest on the outer surface of the cutterblock and the end stop plate is pressed against the rebate side of the back planing table. Position the knife so that its end butts against the stop plate so as to line up the tip of the knife with the edge of the back table.
4. Holding the setting device securely in this position, tighten the securing screws. Before fully tightening the screws, check that they have not moved in the setting process. The cutting edge should now be dead parallel to the planing tables and the edge in line with the back planing table edge.

Check that all the securing screws have been tightened before setting the next knife.

5. Rotate the cutterblock until the next knife is in position and repeat the procedure until all the knives have been set.
6. To check the setting of the knives raise the back table to its top position i.e. the zero mark on the rule or 1/16" above the outer surface of the cutterblock. Place a straight edge on the table as shown in Fig. 8 and rotate the cutterblock by hand until the knife just touches the straight edge. Repeat this check in various positions over the width of the table to ensure the knife is parallel. Repeat this procedure for all knives.
7. When changing cutters it is advisable to check that all the locking screws are adequately lubricated and quite free. Periodically examine for damage or cracks particularly in the hexagon hole. Any doubtful screws should be replaced and all screws well lubricated with "Moly slip" or similar oil before replacing.

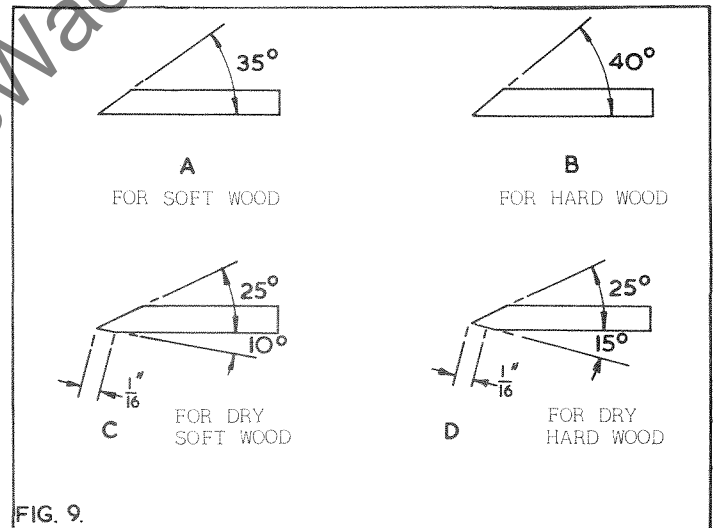
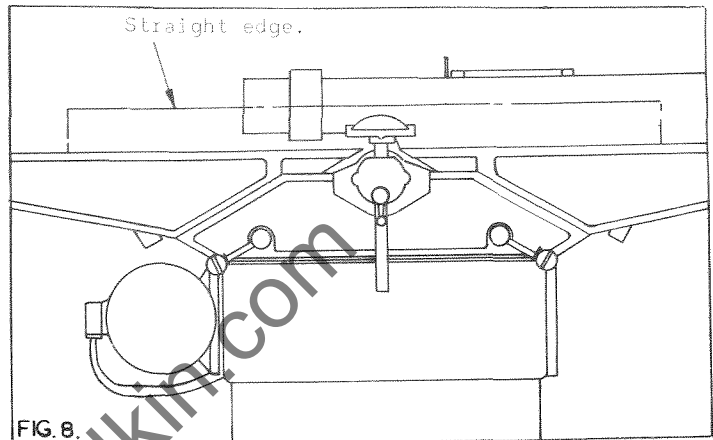

CUTTER CARE

The cutters supplied are 9/4" (235 mm) long x 1/4" (32 mm) wide x 1/8" (3 mm) thick in balanced sets. They should be kept in balanced sets by ensuring that the cutters have equal dimensions after grinding and that the cutter edge is straight and parallel to the back edge.

For general work, knife angles for soft and hard woods are recommended as in Fig. 9 (a) and (b).

When a very fine finish is required in dry soft and hard woods a slight front bevel is given as in Fig. 9 (c) and (d). For wet or green timber the cutting bevel may be decreased five degrees, but the front bevel should not be given.

Keep the cutters sharp when in position by using a fine grade oil stone dipped in paraffin. Allow the stone to rest lightly and flat on the bevel and pass over the cutter with a rotating action a few times. Give about two strokes on the full length of each knife on the face side to remove all burrs from the cutting edge.

Do not allow a heel greater than 1/32" wide on the bevel before removing and re-grinding. When the heel becomes too wide the knives may heat up or have a hammering effect on the wood and more than normal power will be required to run the cutterblock.

Ref. No.	Part No.	No. Off	Description	Ref.	Part No.	No. Off	Description
1.	C-1029/11	2	Foot for base.	36.	A-1029/13	4	Table slide rod.
2.		4	Fillet for base.	37.		8	¼" whit. x ¾" long socket head cap screw.
3.		16	⅜" whit. x ¾" long cadmium hexagon head bolt.	38.		8	¼" whit. x 1" long socket head cap screw.
4.		16	⅜" cadmium washer.	39.	Patt. No. 24	2	2" dia. plastic handwheel, ½" plain bore.
5.	D-1029/22	1	Sheet steel base.	40.		4	½" whit. locknut.
6.	A-1034/14	1	Motor pivot shaft.	41.	A-1029/7	2	Table rise and fall nut.
7.		2	⅜" whit. x ⅜" long socket head grub screw.	42.	A-1029/12	2	Table rise and fall screw.
8.		4	5/16" whit. x 1½" long stud.	43.	B-1029/24	2	Table rise and fall bracket.
9.		4	5/16" washer.	44.		2	½" spring washer.
10.		4	5/16" whit. aerotight nut.	45.		2	½" whit. x 1¼" long socket head cap screw.
11.	2410	2	M section vee belt (50 cycle, 3 Phase & 60 cycle, 3 Phase).	46.	B-1029/16	2	Table locking bar.
	2440	2	M section vee belt (50 cycle, 1 Phase & 60 cycle, 1 Phase).	47.	A-1029/55	4	Table spring.
12.		1	Brook motor, T14, T.E.F.C., 2 HP, 2840 r.p.m. (50 cycle, 3 Phase).	48.		4	⅜" whit. x 2¾" long stud.
		1	Brook motor, M66C, T.E.F.C., 2 HP, 2840 r.p.m. (50 cycle, 1 Phase).	49.	A-1029/72	4	Table spring pressure nut.
		1	Brook motor, T14, T.E.F.C., 2 HP, 3480 r.p.m. (60 cycle, 3 Phase).	50.	A-1029/13	2	Eccentric block.
		1	Brook motor, M66C, T.E.F.C., 2 HP, 3480 r.p.m. (60 cycle, 1 Phase).	51.	44ADS/FO	1	MEM Starter (3 Phase, 50 cycle supply).
13.		1	3/16" wide x 1½" long feather key.	AT3		1	Brook Starter (1 Phase, 50 cycle supply).
14.		2	¼" whit. x ¾" long socket head grub screw.	AT3		1	Brook Starter (3 Phase, 60 cycle supply).
15.	B-1029/75	1	50 cycle motor pulley.	52.		4	¼" whit. x 1" long cadmium Cheese head screw.
	B-1029/78	1	60 cycle motor pulley.	53.		8	¼" long Z6, Mushroom head self tapping screw.
16.		1	⅜" whit. x 3½" long hexagon head bolt.	54.	B-1029/52	1	Chip chute cover.
17.	C-1029/9	1	Motor platform (3 Phase motor).	55.		2	¼" whit. x ½" long round head screws.
	D-1029/60	1	Motor platform (1 Phase motor).	56.		2	⅜" whit. x 3" long hexagon head bolt.
18.		3	⅜" Washer.	57.		1	⅜" whit. x 1" long socket head cap screw (Extra).
19.	A-1024/21	1	Spring for belt tension.	58.		1	⅜" whit. x 1¼" long socket head cap screw (Extra).
20.		3	⅜" whit. aerotight nut.	59.	C-1029/25	1	Rebate table (Extra).
21.	D-1029/3	1	Sub base.	60.	D-1029/70	1	Boomerang guard (Extra).
22.		4	⅜" whit. x 1½" long stud.	61.		1	¼" whit. x ¾" long socket head allen grub screw (Extra).
23.		10	⅜" whit. nut.	62.	A-1029/68	1	Spring holder bolt (Extra).
24.	D-1029/1	2	Planing table.	63.	A-1029/71	1	Swivel pin for boomerang guard (Extra).
25.	Patt. No. 23	2	1¼" dia. plastic ball, ⅜" whit.	64.		1	5/16" whit. x ¾" long square head bolt (Extra).
26.	A-1002/90A	2	Locking handle for table locking eccentric.	65.	B-1029/57	1	Bracket for boomerang guard (Extra).
27.	B-1029/17	2	Table locking eccentric.	66.		2	5/16" whit. x 1¼" long hexagon head bolt (Extra).
28.		1	⅜" whit. x 5" long stud.	67.	A-1029/67	1	Spring for boomerang guard (Extra).
29.	A-1029/59	1	Knurled knob for belt guard.	68.	A-1029/69	1	Spring holder for boomerang guard (Extra).
30.	D-1029/8	1	Belt guard (3 Phase drive).				
	D-1029/61	1	Belt guard (1 Phase drive).				
31.	D-1029/2	1	Main frame.				
32.	A-1029/53	2	Table rise and fall indicator.				
33.		4	3/16" whit. x ⅜" long round head screw.				
34.	A-1029/21	2	Chip guard.				
35.	A-1029/23	1 each	Table rise and fall rule.				
	A-1029/54	1 each	Table rise and fall rule (metric).				

MAIN FRAME ASSEMBLY

www.DaltonsWadkin.com

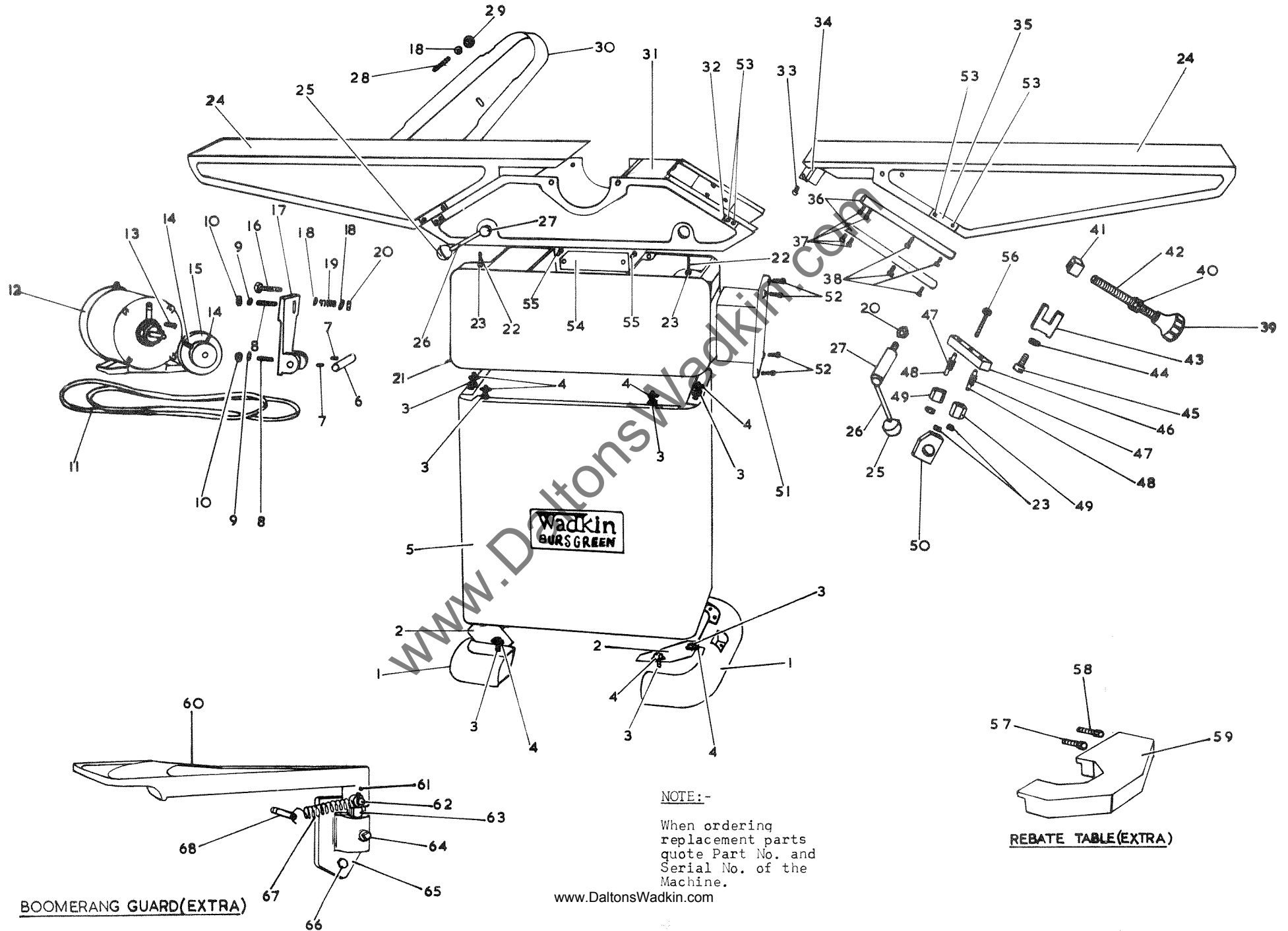

NOTE:-

When ordering replacement parts quote Part No. and Serial No. of the Machine.

www.DaltonsWadkin.com

FENCE ASSEMBLY

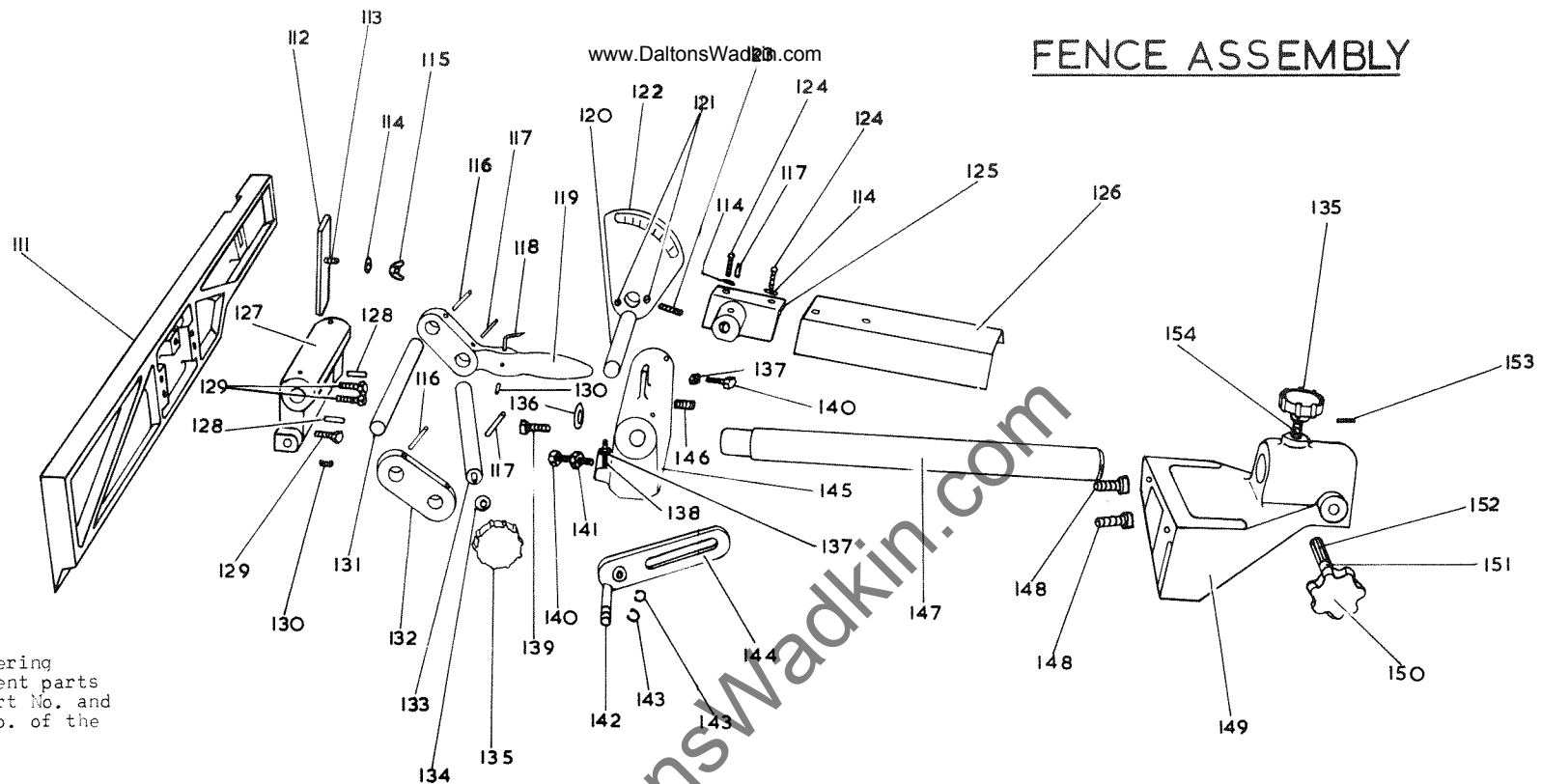

NOTE:-

When ordering replacement parts quote Part No. and Serial No. of the Machine.

Ref. No.	Part No.	No. Off	Description	Ref. No.	Part No.	No. Off	Description
111.	D-1029/65	1	Fence front plate.	134.		1	3/8" Washer.
112.	A 1029/40	1	Adjustable fence plate.	135.	Patt. No. 32	2	1 1/2" dia. plastic handwheel 3/8" whit. bore.
113.		1	1/2" whit. x 1" long stud.	136.	A-1792/67	1	Fence locking washer.
114.		3	1/2" washer.	137.		2	1/2" whit. locknut.
115.		1	1/2" whit. wingnut.	138.		1	1/2" whit. x 3/4" long socket head grub screw.
116.		2	3/16" dia. x 1 1/4" long groverlok spring dowel.	139.		1	3/8" whit. x 1" long hexagon head bolt.
117.		3	3/16" dia. x 1 1/4" long groverlok spring dowel.	140.		2	1/2" whit. x 1" long hexagon head bolt.
118.	A-1029/76	1	Fence Pointer.	141.		1	1/2" whit. nut.
119.	B-1029/34	1	Fence link with handle.	142.	A-1002/67	1	Fence locking link pivot pin.
120.	A-1029/29	1	Back cutterblock guard support bar.	143.	5100 37	2	3/8" dia. external circlip.
121.		2	3/16" whit. x 1/2" long round head screw.	144.	A 1029/39	1	Fence locking link.
122.	B-1029/44	1	Angle indicator plate and boss.	145.	D 1029/31	1	Fence canting bracket.
123.		1	1/2" whit. x 1 1/2" long socket head grub screw.	146.		1	1/2" gas x 1 1/2" long socket head grub screw.
124.		2	1/2" whit. x 1 1/2" long round head screw.	147.	A-1029/42	1	Fence rack bar.
125.	B-1029/35	1	Back cutterblock guard bracket.	148.		2	3/8" whit. x 1 1/4" long socket head cap screw.
126.	A-1029/28	1	Back cutterblock guard.	149.	D-1029/32	1	Fence adjusting bracket.
127.	C-1029/66	1	Fence front plate bracket.	150.	Patt. No. 14	1	2" dia. plastic handwheel 5/16" plain bore.
128.		2	1/2" dia. x 3/4" long fluted dowel.	151.		1	5/16" bore x 1/2" outside dia. x 3/4" long oilite bush.
129.		3	5/16" whit. x 3/4" long hexagon head bolt.	152.	A-1029/41	1	Fence pinion.
130.		2	1/2" whit. x 3/8" long socket head grub screw.	153.		1	1/2" dia. x 3/4" long groverlok spring dowel.
131.	A 1029/36	1	Fence top pivot bar.	154.		1	3/8" whit. x 1 1/2" long brass stud.
132.	B 1029/33	1	Plain fence link.				
133.	A 1029/37	1	Fence bottom pivot bar.				

Mica
0181
445
5476

CUTTERBLOCK ASSEMBLY

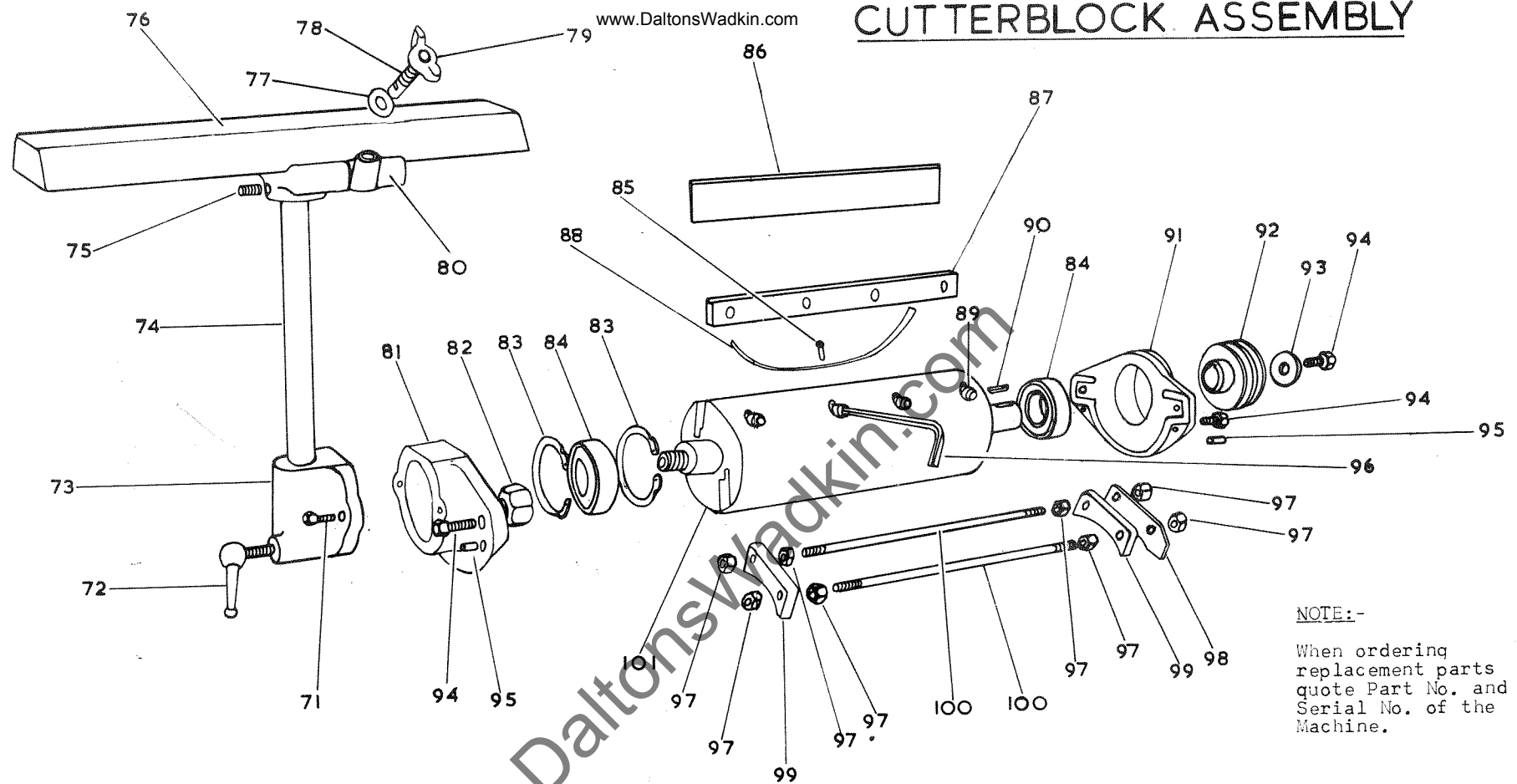

NOTE:-
When ordering replacement parts quote Part No. and Serial No. of the Machine.

Ref. No.	Part No.	No. Off	Description	Ref. No.	Part No.	No. Off	Description
71.		2	5/16" whit. x 1" long hexagon head bolt.	88.	AS-41	2	Cutterblock spring.
72.	B-S-1-B	1	3/8" whit. ball lever screw.	89.		8	1/2" whit. x 1/4" long dog pointed socket head grub screw.
73.	B-1029/6	1	Rebate side bearing cover.	90.		1	1/4" wide x 1 1/4" long feather key.
74.	A-1029/20	1	Cutterblock guard adjusting bar.	91.	B-1029/5	1	Drive side bearing housing.
75.		1	5/16" whit. x 1/2" long Socket head grub screw.	92.	B-1029/74	1	Cutterblock pulley (50 cycle drive)
76.	A-1029/27	1	Front cutterblock guard.		B-1029/77	1	Cutterblock pulley (60 cycle drive)
77.		1	3/8" washer.	93.		1	Cutterblock washer.
78.	A-1029/51	1	Front cutterblock guard locking bolt.	94.		5	3/8" whit. x 1" long hexagon head bolt.
79.		1	3/8" whit. wing nut.	95.		4	1/4" dia. x 1 1/4" long groverlok spring dowel.
80.	B-1029/10	1	Front cutterblock guard bracket.	96.		1	1/4" across flats long arm hexagon wrench.
81.	B-1029/4	1	Rebate side bearing housing.	97.		8	3/8" whit. nut.
82.		1	3/8" BSF left hand nut.	98.	A-1029/49	1	Knife setting device stop plate.
83.	5000-206	2	52 m/m internal circlip.	99.	A-1029/48	2	Knife setting device end plate.
84.	DN205	2	F.B.C. sealed for life bearing.	100.	A-1029/47	2	Knife setting device tie bar.
85.		2	3/32" dia. fluted rivet.	101.	C-1029/14	1	Cutterblock.
86.	B-S-55	1 pr.	Planing knives (9 1/4" long).				
87.	A-1029/56	2	Strip for Cutterblock				

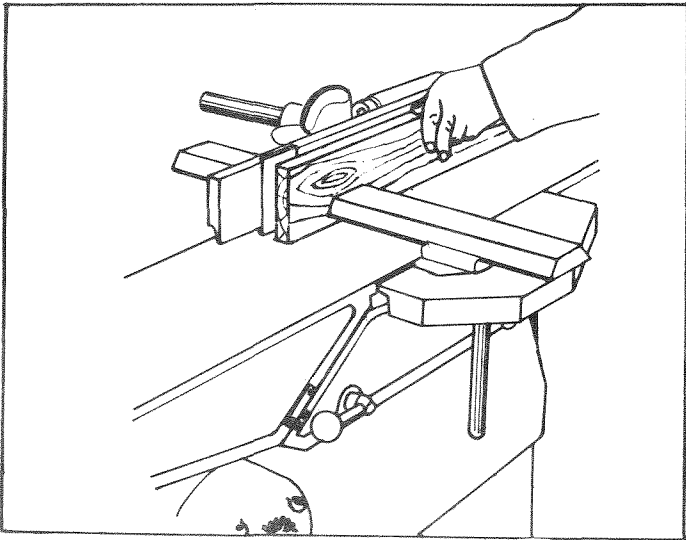

JOINTING (Rebate table is extra)

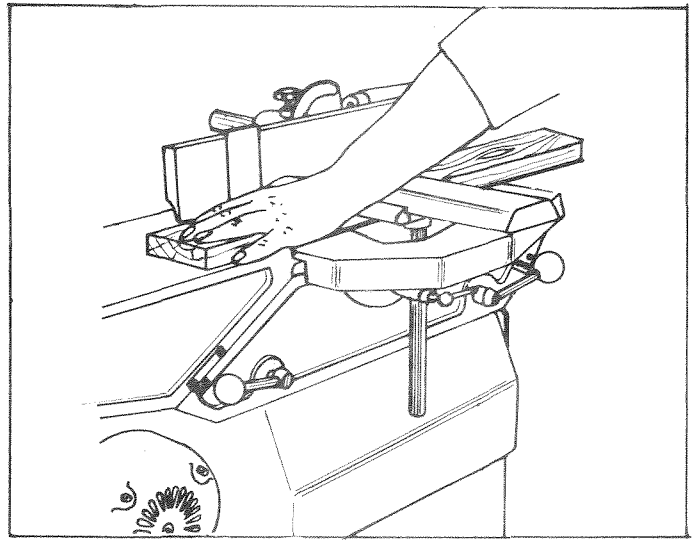

SURFACING (Rebate table is extra)

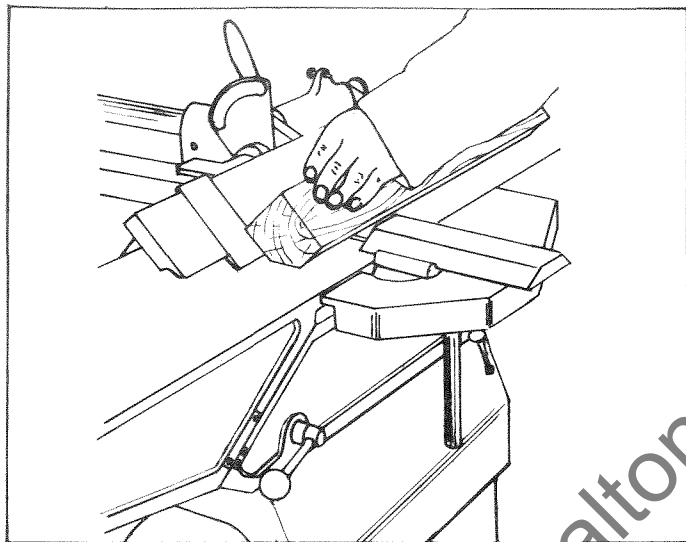

BEVELLING (Rebate table is extra)

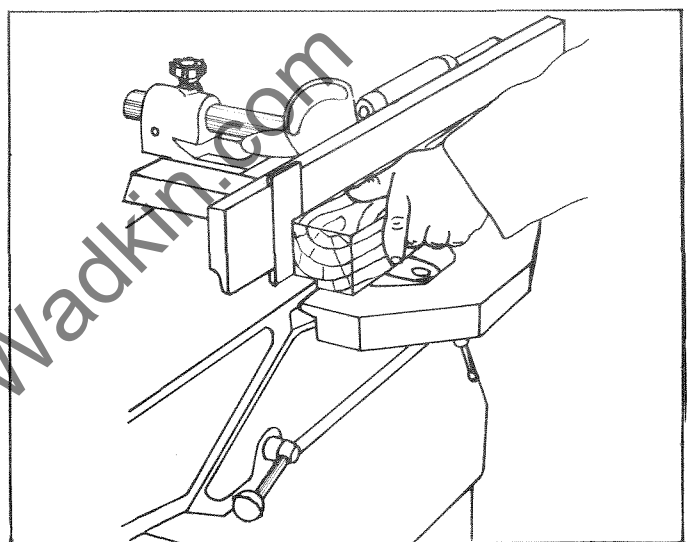

REBATING (Rebate table is extra)

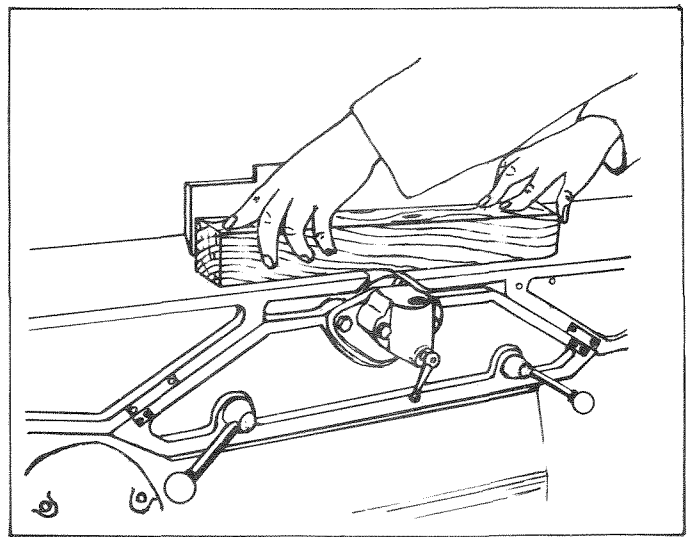
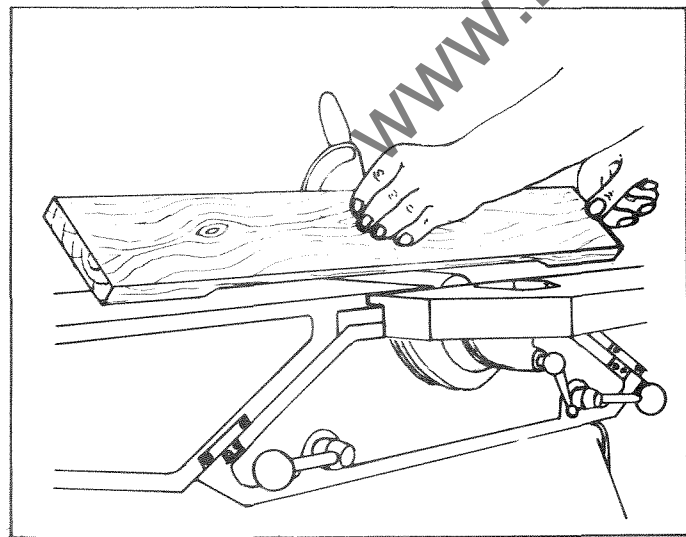

EXTRA EQUIPMENT

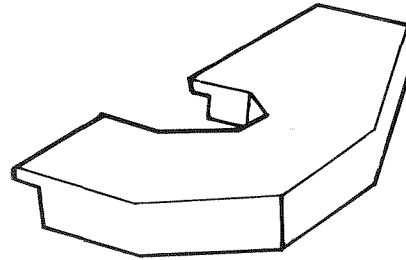
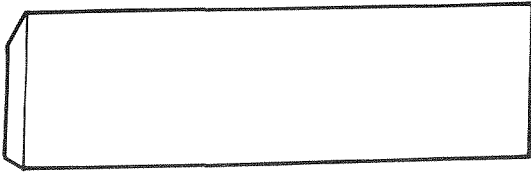

PLANER KNIVES

9 $\frac{1}{4}$ " (235mm) long H. S. S. planer knives B.V.P.37 in pairs or sets of three

REBATE TABLE

A rebate table can be supplied for fitting to the front planing table

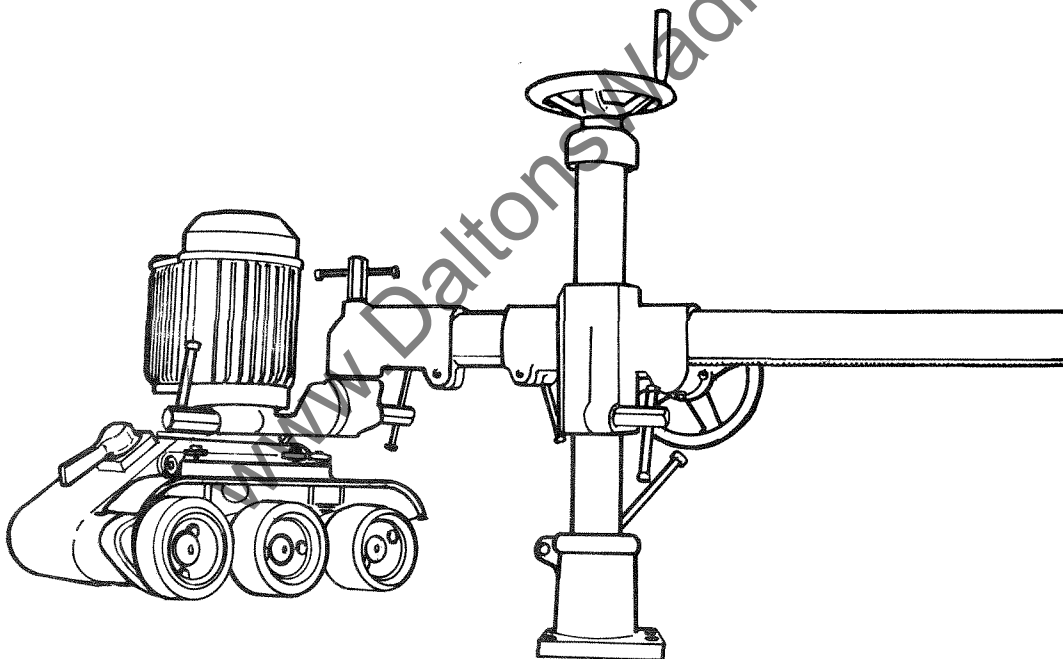

POWER FEED UNIT TYPE BLG.8

The feed unit is supplied with 3 independently sprung rubber tyred feed rollers, two speed electric motor of 0.5/0.7HP and including reversing switch giving 8 feed speed of 6, 13, 16, 19, 33, 39, 49 & 99 feet per minute (2, 4, 5, 6, 10, 12, 15 & 30 m/min)

Standard equipment includes universal stand for horizontal and vertical working, spanner and grease gun.

Please state voltage required.