

Operator's Guide

WA 80



Version 1.8/2007



Index

1	Foreword	1
2	Technical data	2
2.1	Machine identification	2
2.2	Machine data	3
2.3	Noise figures	4
2.4	Assessment of dust emission	4
2.5	Intended use	4
3	Safety	6
3.1	Explanation of symbols	6
3.2	Operational safety details	6
3.3	Safety devices	8
3.3.1	Upper safety hood	9
3.3.2	Riving knives	10
3.3.3	Clamping shoe	11
3.3.4	Push stick	11
3.3.5	Push block (trough-sawing)	11
3.4	Other risks	12
3.5	Working safely with the sliding table saw	13
3.5.1	Cross slide/fence	13
3.5.2	Crosscut fence	13
3.5.3	Rip fence	14
3.5.4	Working examples	15
4	Transport	18
4.1	Packing	18
4.2	Degree of dismantling	18
4.3	Sensitivity	18
4.4	Storage	18
5	Assembly	19
5.1	Setting up the sliding table saw	19
5.2	Sliding table assembly	19
5.3	Installation of table length extension	19
5.4	Installing the safety hood	19
5.5	Electrical connection	20
5.6	Connection of extraction system(customer side!)	22
5.7	Rip fence	22
5.7.1	Installing the table length extension	22
5.7.2	Installation of the rip fence	22
6	Machine configuration	23
6.1	Free cut adjustment of sliding table	24
6.2	Free cut adjustment of rip fence	24
6.3	Adjustment angle cut	25
6.4	0° - Position of the saw blade	26
7	Machine operation	27
7.1	Adjustment of the main saw blade	27
7.2	Changing the main saw blade	28
7.3	Saw blade recommendation	29
7.4	Setting the speed	31
7.5	Table locking	32
7.6	Main switch.....	32
7.7	Switching drives on and off	33

Index

7.8	Motor protection	34
7.9	Scorer saw	35
7.9.1	Saw blade change	36
7.9.2	Adjustment of the saw blade width	37
7.10	Rip fence with DIGIT X	39
8	Trouble	41
9	Maintenance	43
9.1	Lubrication	44
9.1.1	Saw drive shaft	44
9.1.2	Tilt segments	44
9.2	Brake	44
10	Customer service - spare parts	45

www.DaltonsWadkin.com

1 Foreword

Please read these operating instructions carefully before commissioning the machine.

No liability will be accepted for any injury, damage or disruption to operations resulting from failure to comply with these operating instructions!

Persons operating this sliding table saw must have had sufficient instruction and be suitably qualified!

These operating instructions cannot be regarded as a binding type description as the manufacturer may have carried out technical modifications.

The operating instructions must always be available where the machine is being used. They must be read and heeded by any person performing the following activities at or on the machine:

- Operating including set-up, troubleshooting during operation, elimination of production waste, care, disposal of operating and auxiliary materials
- Maintenance, repair, inspection
- Transport

It is necessary to comply with national regulations on health and safety at work and environmental protection, in addition to the operating instructions.

The removal of safety devices, especially safety hoods for the saw blade cover and riving knives, will endanger the operator and may lead to accidents.

Safe work is only possible with a clean machine and a clean environment!

Reproduction of this document or parts thereof is only allowed with our permission!

2 Technical data

2.1 Machine identification

Wilhelm Altendorf	
Maschinenbau	
Wettiner Allee 43 / 45	
32429 MINDEN / GERMANY	
Formatkreissäge / Scie à format / Sliding table saw	
Typ / Type	
Nummer / Numéro / Number	
Baujahr / Année / Year	
Sägeblatt / Lame de scie / Sawblade	min. Ø mm
Sägeblatt / Lame de scie / Sawblade	max. Ø mm
Führungsschlitzbreite des Spaltkeils	13mm
Largeur de l'entaille du couteau diviseur	13mm
Width of riving knife fixing slot	13mm
Elektrischer Anschluß	
Raccordement électrique	
Electrical connection	
Spannung / Tension / Voltage	V
Strom / Courant / Current	A
Frequenz / Fréquence / Cycles	Hz
Phasenzahl / Fases / Phases	3
Hauptmotor / Moteur principale / Main motor	
Fabrikat / Fabricant / Manufacturer	
Typ / Type	
Leistung / Puissance / Power	kW
Nummer / Numéro / Number	
Vorritzermotor / Moteur inciseur / Scoring motor	
Fabrikat / Fabricant / Manufacturer	
Typ / Type	
Leistung / Puissance / Power	kW
Nummer / Numéro / Number	

The type label attached to the machine stand is used to determine the machine identity and further important key data.

Meaning of the specified designations:

Typ:	Machine designation
Nummer:	Machine-specific identification number
Baujahr:	Year when machine was made
Sägeblatt min Ø	Diameter of the smallest permitted saw blade
Sägeblatt max Ø	Diameter of the largest permitted saw blade
Führungsschlitzbreite des Spaltkeils:	Diameter of the guide pins for the riving knife in the riving knife holder

Fig. 2-1: Type label

Test symbol

To document that the machine complies with the basic health and safety requirements as defined in Appendix I of Guideline 98/37/EWG for modifying Guideline 89/392/EWG (Machine Guideline) the machine is identified by the following test symbol: CE symbol, GS symbol and wood dust test symbol.

2.2 Machine data

Manufacturer

Wilhelm Altendorf GmbH & Co. KG

Wettinerallee 43 / 45

D-32429 Minden

Fon (+49) 571 95500

Fax (+49) 571 9550 111

Machine

ALTENDORF-sliding table saw

Type WA80

Usable main blade diameter and associated cutting heights

Saw blade diameter Ø [mm]	Saw blade diameter 0° [mm]	Saw blade diameter 45° [mm]
250	0 - 50	0 - 38
300	0 - 80	0 - 56
315	0 - 87	0 - 60
350	0 - 105	0 - 73
400	0 - 130	0 - 91

Electrical connection

The machine may basically only be connected to a 3 phase alternating current supply with phases L1, L2, L3 since otherwise its braking module can be destroyed. If operated with phase converters, frequency converters or transformer-capacitor combinations the braking modules and the starter unit can be destroyed!

Main saw	Diameter of tool holder	30 mm
	Tilting range of the saw blade	0-46°
	No-load speed	3000/4000/5000 [1/min]
Scorer saw	Diameter of scorer saw blade	120 mm
	Diameter of tool holder	22 mm
	No-load speed	8200 [1/min]
Machine table	Size	900 x 702 ± 5 mm
Sliding table	Length mm	2000,3000,3200 mm
Fences	Cutting width at rip fence (mm)	1000, 1300
	Crosscutting at the crosscut fence	3200 mm
Extraction	Connection support Ø under table	5"
	Connection support Ø for upper safety hood	80 mm
	Overall connection	140 Ø
	Air speed	20 [m/s]
	Minimum air volume	1100 [m ³ /h]
	Vacuum	1500 [Pa]
Environmental conditions	Operating temperature	10 - 40 °C
	Max. rel. humidity, no condensation!	90 %
	No gaseous environment which is explosive or may cause corrosion!	
Weight	Weight of machine	ca.1000 kg
Electrical equipment see DIN EN 60204	Voltage [V] + 5%, - 10%	see type label
	Current [A]	see type label
	Frequency [Hz]	see type label
	Main saw motor	5,5 kW
	Scoring saw motor	0,75 kW

2.3 Noise figures

Emitted noise level [dB (A)]	Emitted noise level at the workplace [dB (A)]	Tool
Idling $L_{WA}=98,1$ Running $L_{WA} = 102,5$	Idling $L_{PA} = 88,5$ Running $L_{PA} = 85,2$	Circ.saw blade 350 x 3,5 / 54 WZ Nominal speed = 4160 1/min

The noise emission values determined according to DIN EN ISO 3746 for the sound power level or DIN EN ISO 11202 for the sound pressure level at the workplace on the basis of the working conditions stated in ISO 7960 Appendix A are as listed in the table.

A measurement uncertainty allowance of $K = 4$ dB (A) applies to the stated emission values.

The specified figures are emission levels and therefore not necessarily the level for safe working. Although there is a relationship between emission and immission level there is no reliable method of deriving from this whether additional precautionary measures are required to protect the user. The factors that influence the current level of immission present at the workplace include the length of exposure, other sources of noise such as neighboring machines and their numbers for example or other processing operations linked to noise emission.

2.4 Assessment of dust emission

The dust emission values – measured in accordance with the “Principles for Testing Dust Emission (Concentration Parameters) from Woodworking Machines” issued by the German trade association's technical committee for wood – are under 2 mg/m^3 . When the machine is attached to a correctly functioning extraction system with an air speed of at least 20 m/s (measured after the join of the two extraction connections) you can assume it is and will stay compliant with the technical reference concentration (TRK) limit for wood dust that is in force in Germany.

The machines bear the GS mark with the additional wood dust mark "holzstaubgeprüft". Consequently, a company operating the machine in Germany is exempt from the obligation to perform measurements at the workplace in accordance with TRGS 553.

2.5 Intended use

The WA80 sliding table saw and the workpiece guide equipment supplied with it are intended to be used exclusively for the following purposes:

- Laminated and unlaminated board materials (e.g. chipboard, coreboard, MDF board, ...)
- Solid wood
- Veneer with a suitable clamping device
- Gypsum plasterboard
- Cardboard
- Dimensionally stable plastics (thermoset plastics, thermoplastics). Sawing these materials does not normally involve any risks in respect of dust, chips, and thermal degradation products.
- Aluminium and aluminium alloys

Tools:

- The chosen saw blade must be suitable both for the specific work cycle (e.g. longitudinal cutting or crosscutting) and for the specific material.
- Only circular blades which are solid chrome vanadium (CV) or tungsten carbide tipped (TCT) and have a minimum and maximum diameter of 250 mm and 400 mm as well as a maximum width of 15 mm are allowed for the main saw and milling/grooving cutter. The middle table strip and the cushioning disc must be removed when using a milling/grooving cutter.
- Blades with a maximum diameter of 120 mm are allowed for the scoring saw.
- **Saw blades made of high-alloy high-speed steel (HSS) are not allowed to be used.**
- **Wobble units are not allowed to be used.**

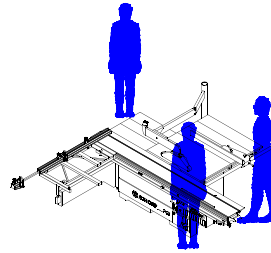
**Site of installation/use:**

- The machine is not suitable for use outdoors, or in rooms that are subject to moisture or the risk of explosions.
- The intended use of the machine involves connection to a suitably dimensioned extraction system.
- Intended use also involves compliance with ALTENDORF's specified operating, maintenance and repair conditions and the safety information contained in the operating instructions.
- The WA80 sliding table saw may only be used, set up and maintained by persons who are familiar with the machine and aware of the dangers.
- The pertinent accident prevention regulations as well as any other generally recognised technical safety and industrial medicine rules must be observed.
- Repair work must be carried out by our own customer service or by an organisation that we have authorised. Only original ALTENDORF spare parts are allowed to be used for this. ALTENDORF will assume no warranty for any damage that is caused by using non-original spare parts.

Machine operator positions:

The sliding table is intended to be operated from the following positions:

- On the left of the sliding table at the front of the machine, seen in the feed direction (main operator position).
- At the front cross-end of the machine on the right of the sliding table when working with the rip fence (make sure you do not move your body or parts of it into the blade rotation area).
- Any person removing the workpieces must stand at the rear cross-end of the machine behind the main table length extension (under no circumstances in the sliding table traverse area).!

Important information:

- Any use extending beyond this counts as unintended. ALTENDORF will not be liable for any kind of injury or damage that may result from such unintended use; the risk thereof is borne by the user alone.
- Modifications by users to the machine or its electrical parts and the use of non-original parts on the machine exclude any liability by the manufacturer for any resultant injury or damage.

3 Safety

3.1 Explanation of symbols



You will find this symbol all information relating to health and safety in this Operator's Guide where there is a danger to life and limb. Please read this information carefully and take particular care in these cases. Please pass the safety information on to other users. As well as the information in this guide the generally-applicable safety and accident prevention instructions must be noted.

3.2 Operational safety details

All machine tools, particularly woodworking machines with manual feed involve a certain risk when handled incorrectly. Therefore always observe the safety information that is summarised in this chapter as well as government and other industrial safety regulations (e.g. accident prevention rules)!

- Never operate the machine without the protective devices intended for the specific work cycle (also refer to "Working safely with the sliding table saw – Working examples"), and do not make any changes that might impair safety.
- Before all work, make sure that the protective and working devices are securely fitted and are not damaged.
- Before changing a tool, rectifying any faults and carrying out repairs, make sure that the machine cannot be turned on accidentally, for example by padlocking the main switch.
- Only use saw blades and grooving tools that comply with European standard EN 847-1.
- Only fit saw blades with the dimensions described in table 1. The diameter of the mounting hole must always measure 30 mm. Loose intermediate rings are not allowed to be used.
- Select the rotational speed so that the maximum permissible rpm specified for the tool is not exceeded when using tungsten carbide tipped saw blades or grooving cutters.
- HSS saw blades and cracked or deformed saw blades are not allowed to be used.
- Always wear tight-fitting working clothes and do not wear rings, bracelets or watches.
- Make sure that the workplace is uncluttered, slip-proof and well lit.
- Do not cut workpieces that are too large or too small for the machine to handle.
- When working at the machine, always stand to the side of the saw blade outside a possible kick-back area (area directly in front of the saw blade).
- Remove any loose parts from the vicinity of the saw blade before switching on the machine.
- Only start cutting when the saw blade has reached its full rotational speed.
- Always use the top safety hood!
- Adjust the height of the top safety hood to the thickness of the workpiece to be cut.
- Always use the riving knife except for insert cuts. The riving knife must not be thicker than the cutting line width or thinner than the main blade. Adjust it so that it is at a distance of most 8 mm from the gear rim. The guide slot must be 13 + 0.5 mm wide. The riving knives supplied with the machine cover the entire range of diameters for the saw blades that are allowed to be used – from 250 mm to 400 mm. With respect to their thickness, they match the cutting line widths of commercially available tungsten carbide tipped saw blades. If other saw blades, e.g. made of chrome vanadium (CV), are used, select a riving knife thickness that lies between the cutting line width and the main blade thickness. Such riving knives can be obtained from the trade or directly from ALTENDORF.
- Use an anti-kick device for insert cuts, e.g. the front of the clamping shoe. Fix this in the sliding table groove, ensuring that the sliding table is locked with its interlock to prevent movement. Following insert cutting, refit the riving knife and the top safety hood immediately.
- Always guide the workpiece safely and use the appropriate stops/fences (rip fence, fence scale, crosscut fence on cross-slides, cross stop) .
- Use a push stick when cutting narrow workpieces (less than 120 mm) at the rip fence.
- Only do crosscuts when the cross-slide is fixed to the sliding table. Make sure that small cut-off workpieces cannot be taken up by the gear rim and kick out, for example by using a deflection wedge.
- Crosscuts and longitudinal cuts in round wood are not allowed with the standard feeding aids or fences/stops.
- For trimming, use the clamping shoe fixed to the sliding table to hold down the workpiece.
- When using a feeding unit, use at least the riving knife as an anti-kick device.
- Replace worn-out table strips immediately.

- Wobble units or wobble cutting devices are not allowed to be used.
- Only use grooving tools with a maximum width of 15 mm that are permitted for manual feeding. This is the case when tools have the inscription “MAN”.
- The sound pressure level at the workplace generally exceeds 85 dB(A). For this reason, wear hearing protection when working.
- The sawdust generated during cutting impairs visibility and is, in part, detrimental to health. The machine must therefore be connected to a chip extraction system with both extraction sockets. The minimum air speed at the lower extraction socket must be at least 20 m/s. When the machine is switched on, the extraction system must switch on at the same time.
- Only qualified electricians are permitted to work on the electrical equipment of the machine.
- Regular cleaning of the machine and, in particular, the main table, sliding table and guides (e.g. rip fence) is an important safety factor. Before starting this work, make sure that the machine cannot be switched on unintentionally.

www.DaltonsWadkin.com

3.3 Safety devices

The machine is equipped with all the necessary safety devices to protect against operating risks that could not be eliminated by its design. These safety devices include, in particular:

- For a max. tool diameter of 400 mm:
 - Top safety hood fitted separately from the riving knife for max. saw blade diameter of 400 mm, available in a narrow and a wide format made of polycarbonate to optimally cover the section of the blade not required for sawing above the machine table with a safeguard against lifting beyond the maximum cutting height of + 5 mm. Rollers integrated in the safety hoods at the leading and trailing ends make it easier both for feeding workpieces and for pulling back of workpieces if workpieces have a slightly different thickness.
 - 3 riving knives for saw blades between 250 and 400 mm diameter to avoid workpiece kick-back as a result of jamming in the cutting line.
 - Rip fence with straight edge adjustable in the cutting direction. Can be pulled back to prevent parts of crosscut workpieces from jamming between the fence and the rising gear rim, or can be switched over to a low guide surface for cutting narrow and flat workpieces, allowing adequate space for the guide hand together with the possibility of lowering the top safety hood onto the workpiece here, too.
 - Trimming hold-down to clamp and hold down untrimmed solid wood to secure against slippage in the course of trimming.
 - Sliding table arresting device to prevent workpiece kick-back for insert cuts together with the cross-stop.
 - Electrical interlocking of the cover plate on the extraction duct beneath the machine table in the vicinity of the saw blades. It is not possible to switch on the machine when the cover plate is open, and if the cover plate is opened while the machine is running, the drives will switch off.
 - Automatic brake which, after switching off, brings the main saw blade to a standstill in less than 10 seconds, regardless of the saw blade diameter and rotational speed.
 - Favorable airflow design of the lower extraction duct and the top safety hood to reduce dust emission to below 2 mg/m³, providing that the machine is connected at both extraction sockets to an extraction system having a min. airspeed of 20 m/s.
- Ergonomic arrangement of the operating elements at readily accessible positions at the machine frame.

3.3.1 Upper safety hood

To protect the saw blade above the table there must be an adjustable removable protection device. (DIN EN 1870-1)

Changing the safety hood

When working with a tilted saw blade replace the narrow hood with the wide hood.

Never replace the safety hood when the saw blade is running!

Replacing the safety hood:

- After releasing the securing screw, pull the hood out forwards.
- To fit it, place the safety hood in the hood carrier
- Push the safety hood up to the end until the two arrows are one above the other
- Tighten the securing screw



Swung away the safety device

You may only work with the swung away safety hood in special cases taking extra care, e.g. with bulky workpieces (carcass). When you have finished, the safety device is to be moved back immediately into its operating position!



Fig. 3-1: Normal position



Fig. 3-2: Swung away position

Swung away the safety device:

- Switch off the main switch and prevent it from being switched on again
- Release the clamping screw
- The safety device can be moved out of the way

After you have finished move the safety hood back into its normal working position!

Lateral adjustment of the safety device

Fig. 3-3: Lateral adjustment

Adjust the protective hood mount by moving it on its arm so that there is a gap of max 15 mm between the edge of the protective hood and the spacer of the saw drive shaft.

This setting is made at the factory and is marked by adjacent red arrows on the attachment bracket and the arm.

3.3.2 Riving knives

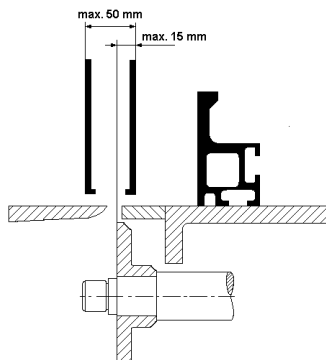
The correct setting of the riving knife is of great importance for safety. The gap between the riving knife and the toothed wheel of the saw blade may not be more than 8 mm in the area of the cutting height. The sensible gap in practice is around 5 mm. Use of the positively guided Altendorf riving knife automatically ensures with this gap that the height adjustment of the riving knife matches the tip approx. 2 mm below the uppermost tooth (see illustration).

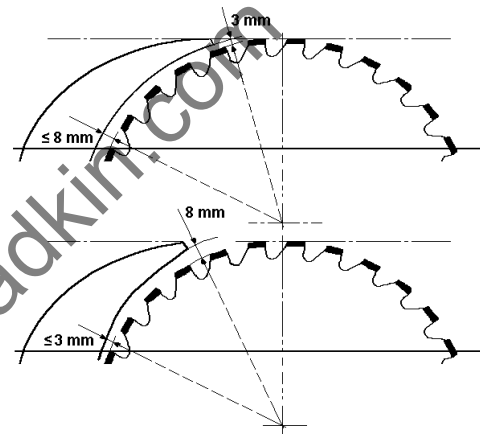
Adjustment

Before adjusting the riving knife you must check whether its size and thickness match the saw blade being used. The series versions of the machine are supplied with the following riving knives: (range of diameters and thickness are stamped on the lower end of the knife in each case)..

250/2,5 for saw blade diameter of 250 mm, with a body thickness up to maximum 2,5 mm

315/2.8 for saw blade diameter of 300 bis 315 mm, with a body thickness up to maximum 2.8 mm.

300-350/2.8 for saw blade diameter of 300 to 350 mm, with a body thickness up to maximum 2.8 mm..

400-450/3.2 for saw blade diameter of 400 mm, with a body thickness up to maximum 3.2 mm.

The thicknesses of the riving knife are selected so that they match the commercially available saw blade thicknesses in the relevant diameter range.

Always switch off the main switch before adjusting the riving knife!

To adjust the riving knife unlock the upper carriage and move it to its end position and lift up the orange protective cover. The supplied SW 19 ring spanner can then be used to release the clamping bolt on the riving knife holder. The riving knife can then be positioned at the correct height by moving it in its slot or adjusting the gap between it and the blade by moving the entire holder on the bar, noting the markings on the riving knife when doing this. Then re tighten the clamping bolt and close the protective cover.

3.3.3 Clamping shoe



The clamping shoe is used for trimming planks and fixes the workpiece securely on the sliding table.

3.3.4 Push stick



For cutting width less than 120 mm the push stick must be used to prevent your hands getting near the saw blade when working. The push stick holder is located close to the work area on the rip fence.

3.3.5 Push block (trough-sawing)



Push blocks should be used for cutting narrower workpieces and if necessary, for pressing the workpiece against the fence. A push block can easily be made by the operator and be fitted with the push block handle supplied with the machine.

3.4 Other risks

Even when the machine is used in accordance with specifications, despite compliance with all safety regulations, because of the construction of the machine which is determined by the purpose for which it is used, the following risks might still arise.

- Touching the main saw blade and the scoring saw blade in the cutting area.
- Touching the main saw blade and of the scoring saw blade below the table level when the sliding table is right forward or right back.
- Recoil of the workpiece or of parts of the workpiece.
- Catapulting off of individual teeth with carbide-tipped saw blades.
- Breakage and spinning off of the saw blade.
- Sticking on the manual or motorized sliding table.
- Sticking between the motorized tilt movement of the saw blade and the rip fence or workpieces located in the tilt area.
- Contact with live parts when electrical installations are open
- Long-term effects of noise when working for long periods without hearing protection
- Emission of dust that can damage your health if operating the machine without dust extraction.

Avoid any dangers that may arise from these other risks by taking extra care when setting up, operating and maintaining the machine!

3.5 Working safely with the sliding table saw

3.5.1 Cross slide/fence

Sizing and mitre cutting

The cross slide is placed on the end bolts of the swivel arm and the circular bar of the upper carriage and clamped with the clamping screws. Depending on the size of the material to be handled this can be done at any point on the upper carriage. For the mitre fence there are two positions on the cross slide.

Position 1

Use: For handling boards

The operator pushes the workpiece in the cutting direction against the fence

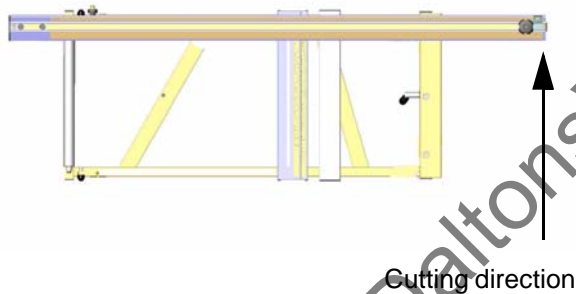

Position 2

Use: For handling wood and boards up to 600 mm width

The operator pulls the workpiece against the cutting direction to the fence

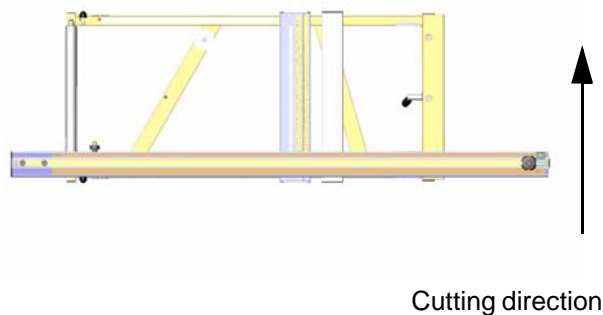

3.5.2 Crosscut fence



Fig. 3-4: Controls

Changing the crosscut fence:

- Raise the clamping lever and press it inward (for release)
- Place the crosscut fence in a new position, making sure that the centring bolts enter the holes
- Raise the clamping lever and press it outward
- Lightly press the clamping lever down (for clamping)

Note:

For dimensions that have to be set with the hinged bar it should be noted that the individual tilt stop is actually against the fence of the cut-out!

3.5.3 Rip fence



Fig. 3-5: Flat position of the extension fence



Fig. 3-6: Extension fence height adjustment

Adjustment

For parallel cutting the rip fence is set to the desired dimension. The dimension set is read off via the edge of the aluminum profile bar. The scale can be adjusted in accordance with the relevant tool thickness after the clamping screw has been released.

For cuts less than 120 mm wide the material must be fed with a push stick and the extended fence must be in a flat position.

The dimension scale can be adjusted to the individual tool thickness after releasing the knurled screw. The extended fence of the rip fence is adjustable in the cutting direction and in the profile height. It is clamped in the desired position using a star knob screw.

Crosscutting

For crosscutting shorter workpieces, for removal (e.g. tenon cutting) or other procedures in which pieces falling off could jam between fence and saw blade, the extension fence is pulled far enough forward for its rear end to be in front of the saw blade.

Flat and narrow workpieces

When handling flat and narrow workpieces the flat extension fence is used. This gives more space to guide the workpiece and the fence can be positioned closer to the saw blade, especially when the saw blade is tilted, without hitting the safety hood..

3.5.4 Working examples

General

The Altendorf sliding table saw Type WA80 is a universal machine which can be used for different cutting jobs. To do this however it is necessary to equip the machine accordingly.

Tool

The first important point is to only use undamaged saw blades, to correctly adjust the riving knife and to move the upper safety hood so that it is positioned closely above the workpiece to be cut. This last point is also of great importance for correct functioning of the extraction facility mentioned above.

Speed

Ensure that the correct speed is set and after switching on the machine, only begin to push the workpiece forward when the saw blade has reached full speed.

Positions of hands

The hands lie flat with the fingers closed on the workpiece; the thumbs are adjacent with a sufficient safety margin to the saw blade.

You will find further notes on safe working in the following description of the individual work processes:

Edge cutting (trimming)



Fig. 3-7: Edge cutting (trimming)

Tool: Ripping circular saw blade

Operation: Mount clamping shoe on the sliding table. Place workpiece hollow side down and press down with clamping shoe. The ball of the right hand is used to apply forwards pressure to the edge of the workpiece. Place hands at a suitable safe distance from the tool.

Ripping of narrow workpieces



Fig. 3-8: Ripping

Workpiece width < 120 mm

Tool: Ripping circular saw blade.

Operation: Adjust rip fence to the desired cutting width. Lower the safety hood in accordance with the height of the workpiece. Move workpiece against the fence with the sliding table; Use the push stick in the area of the saw blade and push the separated workpiece until it is beyond the riving knife. For short workpieces use the push stick right from the start.

Cutting of strips



Fig. 3-9: Cutting of strips

Tool: Circular saw blade for fine cutting

Operation: Set the aluminum scale of the rip fence to the lower guide surface. Place the workpiece on the sliding table and use your left hand to push it against the rip fence. Move the workpiece forward with the sliding table, using the push block in the area of the saw blade and continue to push the strip until it is beyond the riving knife.

Concealed cutting, rebating



Fig. 3-11: Concealed cutting

Tool: Circular saw blade for fine cutting

Operation: For rebating select the cutting sequence so that the strip cut out falls away on the side of the saw blade opposite to the fence. Lower the safety hood onto the workpiece and ensure good workpiece guidance. (left hand pushes the workpiece against the rip fence.)

Crosscutting of wide workpieces



Fig. 3-10: Crosscutting

Tool: Circular saw crosscut blade

Operation: Place the workpiece against the mitre fence, use the left hand to press it firmly against the fence while moving it forward. When the flip stop is used, this is to be flipped up before pulling the workpiece back after cutting and the workpiece withdrawn from the saw blade or the workpiece is only to be removed beyond the rising blade tip.

Concealed cutting, routing



Fig. 3-12: Routing

Tool: Milling router permitted for manual feeding (maximum width 15 mm).

Operation: Close the table opening by a table strip matched to the milling router. Set the tool to the desired routing depth. Leave the riving knife and the rear tool cover in place. On feeding push the workpiece firmly onto the table (otherwise there is the danger of an unintentional insert process)

For crossrouting of narrow workpieces always use the mitre fence.

Crosscutting against the rip fence



Fig. 3-13: Crosscutting

The material is laid against the mitre fence of the cross slide. The desired dimension is set on the rip fence, the extension fence is pulled back to in front of the saw blade after unclamping it and the item to be cut moved with the sliding table. With the extension fence withdrawn the workpiece cannot stick between saw blade and fence.

Crosscutting short and narrow workpieces



Fig. 3-14: Crosscutting

Tool: Circular saw blade for fine cutting.

Operation: Set the magnetic guide piece (not included with the machine) so that workpiece offcuts cannot come into contact with the rising part of the saw blade. Only feed the workpiece using the mitre fence. Do not remove fallen pieces from the vicinity of the tool with your hands.

Dividing up large boards

With this operation the dimension can be set either at the rip fence or at the mitre fence. If you wish to cut out many pieces with the same dimensions from a larger board, the best way to proceed is to first cut off parallel strips at the rip fence and then cut these to the desired dimensions. However as soon as the part pieces are greater than the cutting width of the machine the dimension is set at the mitre fence of the machine.



Fig. 3-15: Dividing up

4 Transport



When transporting the sliding table saw with a crane or fork lift (only fixed-length forks) only lift the machine a little and protect it from shocks!

4.1 Packing

The transport route is a deciding factor in the type of packing. Unless specifically agreed otherwise, the packing corresponds to the packing guidelines HPE laid down by the German body Bundesverband Holzmittel, Paletten, Exportverpackung e.V. and by the VDMA.

The graphic symbols which appear on the packing should be complied with!

4.2 Degree of dismantling

Particular care should be taken when transporting the sliding table saw to prevent damage from external forces or lack of care when loading and unloading.

During transport buildup of condensation as a result of variations in temperature as well as shocks are to be avoided..

4.3 Sensitivity

Particular care should be taken when transporting the sliding table saw to prevent damage from external forces or lack of care when loading and unloading.

During transport buildup of condensation as a result of variations in temperature as well as shocks are to be avoided.

4.4 Storage

If the sliding table saw or the assembly modules are not assembled immediately after delivery they must be carefully stored at a protected location.

When this is done they should be correctly covered so that no dust and no moisture can get in.

The sliding table saw is delivered with a preservative for the bare, non-surface treated parts which protects these parts for around 1 year. If it is stored beyond this period further preservation measures should be undertaken.

5 Assembly

5.1 Setting up the sliding table saw

Foundation

No special foundation is required at the installation site for the sliding table saw. The floor must have suitable load bearing capacity to take the weight of the machine, it must be even and level. If the machine rocks this should be remedied by putting a machine foot underneath it.

Installation site

The installation site for the machine should be selected so that, taking into account its space requirements and the size of the workpieces to be handled, sufficient free space is available around the sliding table saw. In addition the appropriate safe distances from parts of the building and from other machines are to be adhered to so that there is no danger to the operator or to others of being trapped.

5.2 Sliding table assembly

- Place the carriage on the machine stand and secure it with the outer securing screws. Before tightening the screws push against the stop screws!
- Place the middle carriage on the bottom carriage so that the interlock is pointing to the right.
- Push the middle carriage to the right so that the 1st double roller is still just resting on the round bars.
- Carefully push on the top carriage making sure it is not skewed, watch the e-chain and carefully push the guide rails onto the double rollers
- Push the top carriage towards the left, all the way to the stop.
- Fit the back stop and check whether the stop on the top carriage and the stop on the bottom carriage hit the end position at the same time. Adjust if necessary
- Before putting into service check the adjustment of the lower rollers

5.3 Installation of table length extension

- Guide the pins of the table length extension into the holes on the face of the table plate
- Secure loosely to the table plate with two M10 nuts and shake proof washers
- Tighten the M10 nuts

5.4 Installing the safety hood

- Push the safety hood support onto the attachment bolts
- Put on shake proof washers and secure with nuts

5.5 Electrical connection



All work on the electrical system, including connection to the power network, may only be performed by an electrical specialist. When working on the electrical equipment the machine must be disconnected from the mains power.

The electrical connections are made in the main switch housing which is on the front of the machine stand. The terminals for the leads are marked L1, L2, L3, N and PE, the terminal for the floating contact is marked POT. The lead is 2.5 mm² in cross section and 25A fuses are to be provided on the operating side.

If the machine is connected via a movable lead, a rubber tube lead (lead designation H07RN-F) must be used. Plug connector required: Round plug connector according to DIN 49463.

After the lead is connected the direction of rotation of the main saw motor is to be checked by briefly turning the machine on and if necessary corrected by swapping two external leads in the mains connection box.

Note the arrow indicating direction of rotation on the saw blade cover!



Fig. 5-1: Main switch



Fig. 5-2: Main switch, POT-contact

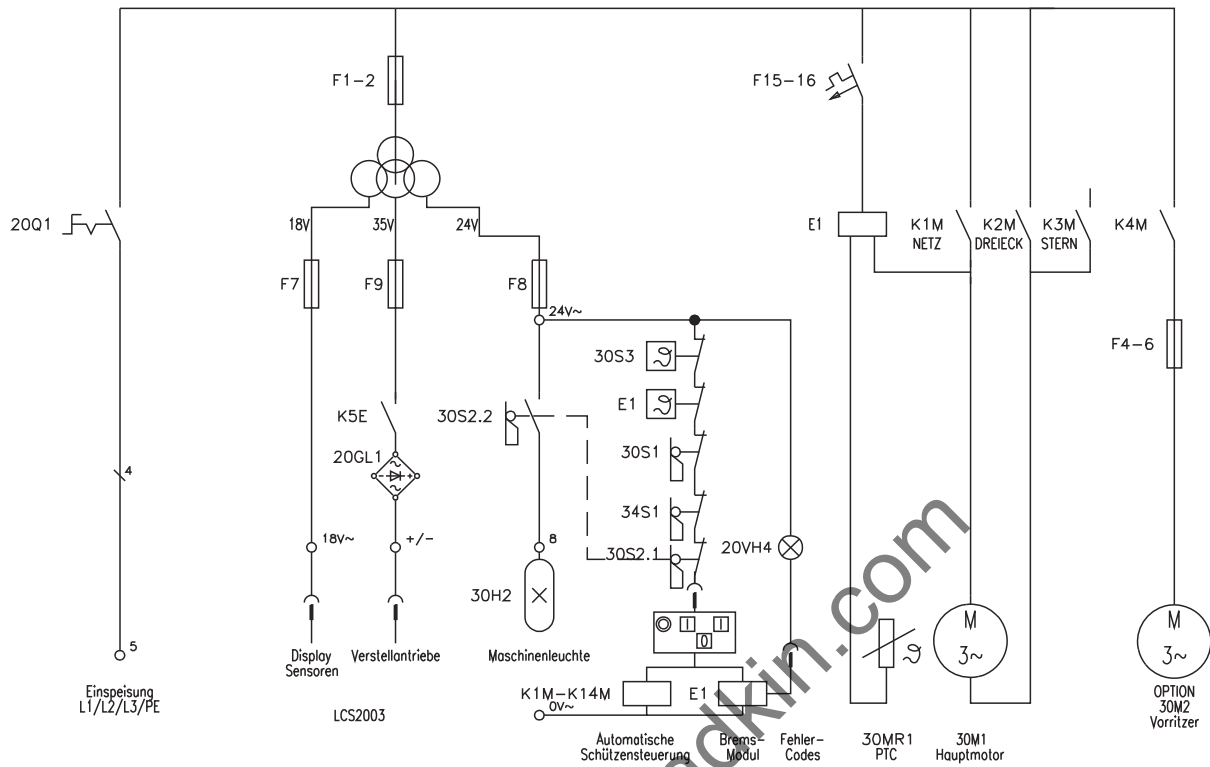

Fig. 5-3: Circuit diagram

Short designation	Name
20Q1	Main switch
F1-F2	Control fuse (primary)
F7-F9	Control fuse (secondary)
F15-F16	Fuses, brake current
30S1	Safety switch sliding table
34S1	Cover plate safety switch
E1	Brake module LCS
20GL1	Rectifier
30M1	Main saw motor
30M2	Scoring saw motor
30MR1	Main motor temperature monitor

5.6 Connection of extraction system(customer side!)

The dust emission values – measured in accordance with the “Principles for Testing Dust Emission (Workplace-Related Dust Concentration) from Woodworking Machines” issued by the German trade association's technical committee for wood – are under 2 mg/m^3 . When the machine is attached to a correctly functioning extraction system with an air speed of at least 20 m/s (measured at the connection socket) you can assume it is and will stay compliant with the technical reference concentration (TRK) value for wood dust that is in force in Germany. For perfect and safe operation, the machine must be connected to the extraction system at the extraction sockets (rear of machine frame and safety hood support). The minimum air speed at the extraction sockets must be 20 m/s . The 80 mm extraction hose from the hood to the connection socket on the support tube is not supplied as standard. The extraction socket and hoses are not supplied as standard!

In addition, make sure that the extraction system is switched on together with the machine. For this, you can use the existing potential-free contact (POT - refer to circuit diagram) or a current transformer installed in the supply line.

5.7 Rip fence

5.7.1 Installing the table length extension

- Guide the bolts of the table length extension into the side holes of the table plate
- Secure loosely to the table plate with two M10 nuts and shake proof washers
- Push through the tensioning pins
- Tighten the M10 nuts

5.7.2 Installation of the rip fence

- Guide the stop bar with the threaded bolts into the holes in the table plate
- Install the washers and nuts
- Tighten the nuts
- Install the belt scale
- Push on the fence
- Install the fence scale

6 Machine configuration

The basic machine settings are made in the works during final assembly. Dismantling various modules, transport and assembly at the installation site can mean that it is necessary to correct the machine settings. The machine parts to be checked are described below.

Checking the lower rollers

The lower rollers must move smoothly at the start and end of the running surface over the starting angle. They should be set so that they can be stopped manually by exerting a perceptible force and slide freely while the sliding table is moved.

Adjustment of the lower rollers

The lower rollers are supported eccentrically and adjustable. If they are set too tight the sliding table is hard to move

Checking the table plate

Place a straightedge on the sliding table, carriage in mid position. Move carriage backwards and forwards, Table plate must lie about 1/10mm lower.

Adjustment of the table plate

Loosen the locknuts on the 4 fixed bolts, Adjust the table plate, tighten the nuts. Then lay the straight-edge in parallel to the sliding table on the table plate.

6.1 Free cut adjustment of sliding table

Checking

Free cut sliding table

Set saw blade to max. cutting height, cut a short piece of a test piece (where possible MDF) at the mitre fence. The difference in the noise between the cutting and non-cutting teeth allows you to determine whether the sliding table is set correctly. On the passage of the rising teeth a slight fluttering noise should be heard compared to the noise of the cutting teeth.

Adjustment

Release the sliding table attachment at both ends **and** in the middle (where present). Release the lock nuts on the fence screws. Make the appropriate adjustments and re tighten the lock nuts. Then readjust the sliding table and tighten all securing screws again.

6.2 Free cut adjustment of rip fence

Checking

Free cut rip fence

Set the saw blade to its max. cutting height, cut a 300x450xmm test piece (where possible MDF) at the rip fence. The noise of the rising teeth must be the same as for the free cut on the left with correct adjustment of the sliding table.

Adjustment

Release the bolts connecting the table extension to the circular rod. Then, by adjusting the center lock-nuts, change the position of the circular bar and thereby of the rip fence.

When a scorer is used ensure that both free cuts are set to approximately the same!

6.3 Adjustment angle cut

Checking

Angle cut

Before the angle cut is checked the adjustment of the sliding table must be checked and corrected if necessary..

The angle cut is checked at the mitre fence as follows:

Take a 1000x1000 mm plank or sheet of MDF, thickness at least 19 mm. Make 5 cuts (see Fig. 1), laying the last cut side against the mitre fence for the next cut (turn the board in a counterclockwise direction). On the 5th cut cut off a strip about 10 mm wide. Measure the width of the strip at both ends with a gage. The difference between the two dimensions divided by 4 gives the angular error per meter cutting length.

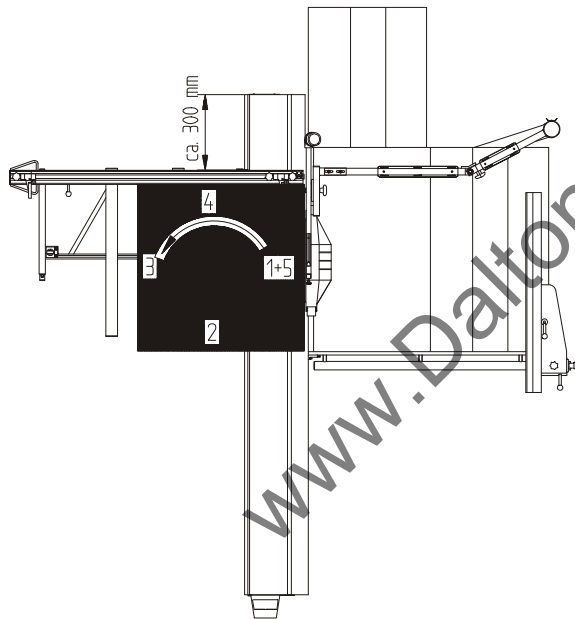

Fig. 6-1: Angle cut

Adjustment

The mitre fence is clamped in the position shown in the illustration (appr. 300 mm from the end of the table) and in a further position (appr. 1300 mm from the end of the table). In these two positions the angle cut, is checked and adjusted, as described above. The adjustment may not exceed an allowable max. tolerance of < **0.2 mm** (on the 5th cut (dimension 1 - dimension 2)).

The angle cut must be checked at least 2 different positions of the mitre fence on the sliding table.

6.4 0° - Position of the saw blade

Checking

Lay 2 strips (appr. 70 mm wide) **on edge** in front of the mitre fence, cut them in this positions and push the cut surfaces together. If the setting is exact the cut edges are parallel, i.e. there is no air gap detectable between the cut edges.

Adjustment

Recalibrate the machine!

www.DaltonsWadkin.com

7 Machine operation

7.1 Adjustment of the main saw blade

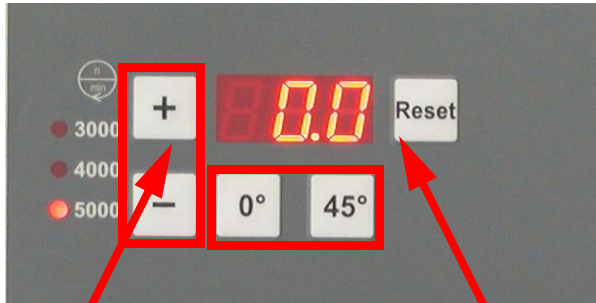

Fig. 7-1: Control System

Cutting height adjustment

Tilt adjustment

Calibrating the tilt angel display

- Tilt the saw blade into the vertical position and check the 90° angle
- Press the RESET key for 3 seconds, the displays shows 0, the machine is calibrated

Rise and fall adjustment

- The cutting height is reduced by pressing the - key.
- The cutting height is increased by pressing the + key
- When the Plus key or the Minus key are held down the saw blade moves for 2 sec. in creep mode and then switches automatically to fast mode

Tilt adjustment

- The angle of tilt is reduced by pressing the 0°- key.
- The angle of tilt is increased by pressing the 45° key
- When the 0° key or the 45° key are held down the saw blade moves for 2 sec. in creep mode and then switches automatically to fast mode
- Tapping the 0°/ 45° keys briefly makes an adjustment of 0.1° in each case!



Calibrating the tilt angel display

- Clear the main table of any workpieces in the tilting area
- Move the scale of the rip fence into the flat position for a cutting width <130 mm!

7.2 Changing the main saw blade

The following basic points should be noted:

- Do not fit any saw blades that have cracks or are damaged in any other way.
- Only fit saw blades with a diameter of between 250 and 400 mm
- Check that the speed set for the saw blade is not too high. For composite saw blades the highest permitted speed is shown on the blade in the form $n_{max} = \dots$

Please note that only saw blades with adjacent holes (2 holes 10 mm \varnothing spaced at 60 mm) can be tensioned. This is necessary to prevent the saw blade securing system becoming loose during braking..

Changing the saw blade



- Switch off the drives
- Set the saw blade to the upper height setting and tilt to 0°
- Switch off the main switch
- Move the upper carriage to the middle of the saw drive shaft, Unlock the lock in the center
- Push the upper carriage in the cutting direction
- Raise the orange cover plate
- Use the key to release the screw in the expansion head tensioning screw
- Unscrew the expansion head screw by turning it to the left with the flange
- Before fitting the new scoring blade, remove any adhering chips and dust from both flanges
- Place the saw blade and front flange on the saw drive shaft and screw in the expanded head screw by hand and tighten it with the key
- Check the riving knife with regard to its strength and distance from the saw blade

Close the lower protective cover and perform a short test run to see whether the saw blade is running freely. Do this by lowering the upper safety hood down to the table so that the saw blade is completely covered.

Warning!

Check saw blade retaining disc for tightness before operating machine!

After the saw blade has been changed it is vital to make the correct riving knife adjustments!

7.3 Saw blade recommendation

Main saw blade

Workpiece	Cutting speed- [m/s]	Saw blade Cut Ø= 250 mm	Saw blade Cut Ø= 300 mm	Saw blade Cut Ø= 350 mm	Saw blade Cut Ø= 400 mm	Saw blade Finishing Ø = 250 mm	Saw blade Finishing Ø = 300 mm	Saw blade Finishing Ø = 350 mm
Softwood lengthwise	60 - 80	24 W	28 W	32 W	36 W	40 W	48 W	54 W
Softwood crosswise	60 - 80	40 W	48 W	54 W	60 W	48 W	60 W	72 W
Hardwood lengthwise	60 - 80	24 W	28 W	32 W	36 W	40 W	48 W	54 W
Hardwood crosswise	60 - 80	40 W	48 W	54 W	60 W	48 W	60 W	72 W
Veneers	70 - 80	60 W	72 W			80 W	96 W	
Plywood	50 - 70	40 W	48 W			48 W	60 W	
Blockboard	60 - 80	48 W	60 W	72 W		60 W	72 W	84 W
Laminated wood	50 - 80	40 W	48 W	54 W		60 W	72 W	84 W
Raw chipboard	60 - 80	48 W	60 W	72 W		60 W	72 W	84 W
Coated chipboard	60 - 80	60 TF	72 TF	84 TF		80 TF	96 TF	108 TF
MDF-raw boards	60 - 80	48 W	60 W	72 W		60 W	72 W	84 W
MDF laminated	60 - 80	60 W	72 W	84 W		80 W	96 W	108 W
Laminate floorings	50 - 70	60 TF	72 TF	84 TF		80 TF	96 TF	108 TF
Hard fiberboard	60 - 80	60 W	72 W	84 W		80 W	96 W	108 W
PVC-Profiles *	40 - 60	60 TF	72 TF	90 TF		48 DD	60 DD	72 DD
Clear acrylic sheets	40 - 50	60 W	72 W	84 W		80 WF	96 WF	108 WF
Plasterboard sheets	40 - 60	48 W	60 W	72 W		60 W	72 W	84 W
Aluminium-Profiles *	60 - 70	60 TF	72 TF	90 TF		80 TF	96 TF	108 TF

Abbreviations:

- * negative tensioning angle
- W Alternate tooth
- TF Trapezoidal flat tooth

- When selecting tools ensure that no blunt or damaged tools are fitted.
- The highest permitted speed specified on the tool may not be exceeded.
- HS-Sägeblätter dürfen nicht verwendet werden!
- The tools must have a hole diameter of 30 mm and driving pin holes of 10 mm Ø in a 60 mm Ø semicircle.
- The correct choice of saw blade depending on the material to be handled and the strength of the material is vitally important, along with the correct cutting speed for clean cutting and low stress on the operator. A selection of saw blades for the Altendorf sliding table saw is shown in the table (p.29). This table makes no claims to be complete. Since the figures for the cutting speed cover large ranges in some cases it is vital to determine the best cutting speed for optimum cutting results by trial and error!

Scorer saw blade

Scorer saw blade: D=120 mm, 24 teeth, flat tooth, arbor diameter 22 mm

Riving knife

The riving knives supplied are suitable in size for the range of saw blade diameters specified in the table. The corresponding range is specified on the bottom end of the relevant riving knife.

The thickness of the riving knife is however only correct where the blades concerned are commercially available carbide-tipped saw blades. For CV saw blades other riving knives are required.

www.DaltonsWadkin.com

7.4 Setting the speed

The following speeds can be set on the main drive by changing over the belt : 3,000, 4,000, 5,000 revolutions/minute.

Speed change

- Switch off drive
- Press the EMERGENCY OFF button
- Move lever down until it engages
- Set speed control to the desired speed setting, position the belt accordingly
- Lift the lever

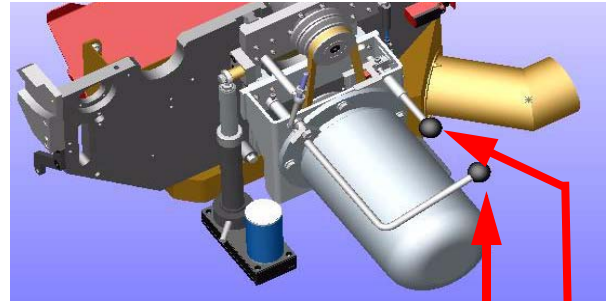

Fig. 7-2: Changing the speed

Lever

Speed control

The belt tension is set automatically after the belt is moved!

7.5 Table locking

The sliding table lock automatically blocks the sliding table in its end position, so that the items for cutting can be pushed against the mitre fence without any undesired movement of the easy to move sliding table. The table is unlocked by turning the lever at the end of the upper carriage by hand.



Fig. 7-3: Locking

With an additional locking adjustment the sliding table can be blocked in its center setting with the carriage lock.

7.6 Main switch

Before the saw drives are switched on the main switch must be set to position I.

The main switch is BLACK which means that this main switch has no EMERGENCY OFF function! When the main switch is used to turn the machine off the saw drives stop with no braking!

7.7 Switching drives on and off



Fig. 7-4: Operating panel



Fig. 7-5: Operating panel on eye level

Before switching on the machine ensure that all the necessary protective devices for the relevant operation are fitted and operational. Also check that the saw blades are correctly tensioned and that there is no workpiece or other objects in their vicinity. Check that the correct speed for the saw blade and for the operation to be performed has been preselected. Check by switching on briefly that the circular saw blade is rotating in the right direction.

Ensure that when you switch the machine on you are simultaneously switching the extraction system on.

The main saw is started by pressing the white button I located in the panel and identified by the main saw symbol. The machine runs up to its operating speed (with start current reduction) automatically. The scorer saw can only be started after the main saw has reached its operating speed (after around 5 seconds.), by pressing the white button II which is also located in the panel and identified by the symbol for the scorer saw. After the scorer saw is switched on this button lights.

To switch off normally the black button labeled „0“ next to the on buttons is pressed. When the off button for the main saw is pressed both saw drives are switched off, the scorer saw can however also be switched off on its own with the corresponding button.

The machine can also be switched off with the EMERGENCY OFF-buttons on both sides of the sliding table. This facility for switching off the machine should however only be used in emergencies

7.8 Motor protection

If the motor protection cuts in it is a sign that the motor is being overloaded and the cause must be identified and rectified before the machine is switched back on (e.g. blocking of the drive by a jammed workpiece, feed too great or failure of a mains phase)

The drive motors are protected against overload by a coil protection. If the motor gets too hot this automatically switches the motor off. Note here that for machines with scorers this drive is switched off as well, even if this motor was not overloaded. The machine cannot be switched back on until the motor has cooled down. The motor can take several minutes (max. 10 minutes) to cool down!

Rapid flashing (frequency 4Hz) of the main saw ON button signals that the motor protection has cut in.

Checking the winding protection

The resistance figure ($750 \text{ Ohm} \pm 200 \text{ Ohm}$) of the PTC resistors is to be checked at least once a year in the motor terminal box by a specialist electrician. The test voltage of the meter may not exceed 1.5V for this test!

www.DaltonsWadkin.com

7.9 Scorer saw

The Altendorf scorer saw was developed to enable boards coated on both sides to be cut on the underside without damage.

The material is only cut into by around 1-2 mm by the scorer or the underside and then separated from the main sheet. The blade of the scorer must be precisely aligned to the main blade and set to the corresponding width.

- Two-piece scorer blades are to be recommended which are adjusted to the required blade strength by insertion of distance pieces. The cutting widths of the scorer blades should be at least 1/10 mm wider than those of the main blades, i.e., 5/100 mm to each side. In addition the two scorer blades should feature driver pins and the width should be printed on the spacers.
- The scorer saw can only be started after the main saw has reached its operating speed (after around 5 seconds.), by pressing the white button I which is also located in the panel and identified by the symbol for the scorer saw.



Fig. 7-6: Scorer adjustment

Lateral adjustment

Height adjustment

Adjustment

Height and lateral adjustments are made mechanically and can be performed when the machine is running.

7.9.1 Saw blade change

The description of saw blade change only applies to divided scorer saw blades and also to saw blades with stepless cutting width adjustment. Only use saw blades with a diameter of 120 mm and 22 mm arbor diameter!

- Switch off the drives
- Move scorer saw into its highest position
- Move sliding table in cutting direction
- Unlock the lock in the middle of the saw blade by pressing the spherical button on the center carriage
- Move the sliding table into its end position in the cutting direction
- Raise lower protective hood (orange hood)
- Die Befestigungsmutter durch Linksdrehen lösen
- Before fitting the new scorer saw blade clean off any sawdust adhering to the two flanges
- Place the saw blade and front flange on the saw drive shaft and tighten the nut in a clockwise direction

In addition the following points should be noted when using **RAPIDO** scorer saw blades with stepless cutting width adjustment :

- Ignoring the operating instructions reduces operational safety impermissibly and leads to exclusion of liability
- max. speed =8200 1/Min
- Permitted cutting width 2.8 - 3.8 mm
- The adjuster unit must be unpacked and packed with particular care, danger of injury!
- Only store the adjuster unit in its original packing!
- The scorer saw blade must be installed outside the machine
- **All** connecting elements must be installed
- If the connecting elements are lost or damaged only original spare parts may be used as replacements!

7.9.2 Adjustment of the saw blade width

Standard saw blade

- Use spacers to bring the scorer saw blade to the width which is 0.1 mm greater than the width of the main saw blade
- Set the alignment of the scorer to the main saw first on the table plate side
- Test cut
- Set the alignment on the left side by adding or removing intermediate rings

Saw blade with stepless cut width RAPIDO



Fig. 7-7: Release the clamping screw

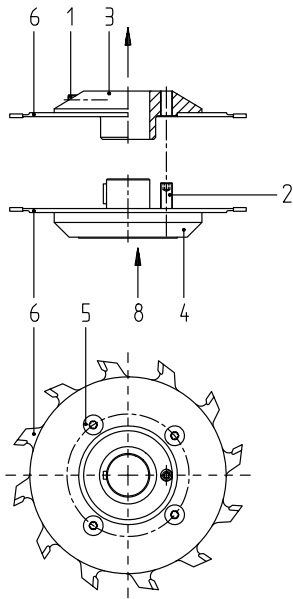

Fig. 7-8: Turn the spindle

Only use the tool supplied for adjustment work!

- Release the clamping screw, appr. 2 turns
- Turn the spindle until the desired dimension is reached. (1 turn = 0.5 mm)
- Tighten the clamping screw
- Test cut, if necessary correct the cutting width again as described above.

Replace scorer saw blades for RAPIDO



Take the adjuster unit off the machine; the clamping screw may have to be released since a tightened clamping screw can cause the adjuster unit to jam on the shaft!

Dismantling:

With hexagonal key:

- Release clamping screw (1) appr. 3-4 turns, rotate spindle (2) clockwise until the flange (3) can be pulled away from holder (4)

With Innentorx key:

- Unscrew screws (5)
- Remove circular saw blade (6)
- Fully clean flange (3) and screws (5). The running and flange surfaces must be clean and dust free.
- Fit a new circular saw blade, note direction of rotation and arbor image when fitting: The circular saw blade (6) lies flat on the flange (3) and the protrusion on the circular saw blade points to the contact surface
- Screw in screws (5) and tighten to a torque of 8,6Nm
- Proceed in the same way with the other half of the adjuster unit

Assembly:

Do not oil or grease!

- Clamping screw (1) is released
- Fit the flange (3) vertically on to the holder (4) so that the spindle (2) engages in the threaded hole (7)
- Use the hexagonal key to turn the spindle (2) in a counterclockwise direction. The flange (3) will be pulled into the holder (4) no additional force may be used here
- Continue to turn spindle (2) until the two halves of the circular saw blade are lying against each other
- Install the adjuster unit on the machine
- Setting the cutting width, see above
- Only turn clamping screw (1) slightly

7.10 Rip fence with DIGIT X



Fig. 7-9: DIGIT X

The electronic measuring system with digital display and precision setting guarantees for a precise and fast rip fence setting. The display with its large luminous digits is visible from every point of the machine. The system functions wear free and is saw dust resistant. System calibration is easily and quickly done by means of the keypad. A particularly practical feature: when changing the stop fence from 90 to 15 mm stop height, the dimensional correction in the measuring system is automatic.

Battery change



Fig. 7-10: Loosen clamping screws



Fig. 7-12: Detach the display housing



Fig. 7-11: Loosen and withdraw screws and remove cover



Fig. 7-13: Insert/replace batteries, ensuring correct polarity!

Basic settings of the display electronics



Fig. 7-14: Display DIGIT X

The basic setting of the display electronics is required in order to adapt the measuring system to the individual machine situation. Check and, if necessary, re-enter the basic setting for each tool change. Knowing that the basic setting can only be performed in conjunction with the tools actually used, factory setting is not possible.

- Push the rip fence to the left against mechanical stop
- Keep the F Key pressed while pressing RESET
- Set the rip fence to 130 mm cutting width (flat position)
- Cut the trial piece and measure the workpiece width using a sliding caliper
- Press and keep the F key pressed, the right-hand position of the display starts flashing after 3s
- Use the + key to increase the value of the flashing digit by 1 with each key actuation. When exceeding the max. number value (9), the numbers start again with 0
- The value of the flashing digit can be decreased by 1 with each actuation of the - key.
- Release the F key
- The set dimensions is saved as a basic setting value

Calibration the display electronics

Calibration of the display electronics is required when the fence position was changed while the machine was switched off or when the saw blade was changed.

- Push the rip fence to the left against the mechanical stop
- Keep the F key pressed while briefly actuating the RESET key. The basic setting value reappears in the display

Switch dimension, mm and inch

- Keep key + pressed for more than 3 s. The display will show inch (mm)
- Release key +, the display electronics now show the set dimension in inch (mm)

8 Trouble

There is generally an increased danger involved in troubleshooting. Therefore you should make sure that you take particular care when performing the actions required.



Fault	Cause	Remedy
Machine cannot be switched on	The main switch is not switched on Mains failure or Failure of a phase Overload protection has triggered Sliding table moved beyond middle of saw blade EMERGENCY OFF button pressed Door on machine stand or lower protective cover in front of the saw blades opened Control circuit fuses defective	Switch main switch to position „I“ Wait for power to return or Remedy cause of power failure (e.g. defective operational side fuses) Wait for motor to cool down Pull sliding table back in front of saw blade Release the EMERGENCY OFF button again by pulling it Close door or lower protective cover Switch off the main switch, open switching cabinet and determine which of fuses F1, F2, F8 is defective. Clarify and remedy cause. Replace defective fuses, use fuses of the same ratings as replacements!
Machine switches off by itself during operation	Power failure in one or more phases through activation of the operational side fuses Overload protection triggered by blunt saw blade or feeding the workpiece too quickly Control circuit fuses defective	Remedy cause of phase failure Change saw blade or Reduce feed speed. Wait for motor to cool down Switch off the main switch, open switching cabinet and determine which of fuses F1, F2, F8 is defective. Replace defective fuses, use fuses of the same ratings as replacements!
Workpiece sticks on feeding	Blunt saw blade Thickness of riving knife does not match saw blade being used	Tension sharp saw blade Fit correct riving knife with a thickness greater than or equal to the master blade thickness of the saw blade
The finished dimension of the cut workpiece does not correspond to the cutting width set at the rip fence	Scale for cutting width display incorrectly adjusted	Readjust scale. Cut workpiece at rip fence, measure cutting width and move measuring scale so that the measured cutting width is shown on the edge of the straightedge
Tilt arm moves jerkily	Tilt arm moves jerkily	Clean telescopic tube or track rollers; Test stripper

Fault	Casuse	Remedy
The finished dimension of the cut workpiece does not correspond to the cutting width set at the crosscut fence	Scale for cutting width display incorrectly adjusted	Readjust scale. Cut workpiece at rip fence, measure cutting width and move measuring scale so that the measured cutting width is shown on the edge of the straightedge
Sliding table has sideways play	Lower rollers incorrectly adjusted	Adjust lower rollers
Sliding table in end positions higher than machine table	Lower rollers incorrectly adjusted	Adjust lower rollers
Saw blade burns on the sliding table side	Insufficient free cutting space of sliding table	Adjust free cut
	Free cut adjustment of rip fence too great	Adjust rip fence
Saw blade burns on the rip fence side	Insufficient free cut of the rip fence	Adjust free cut
Saw blade burns on both sides	Incorrect free cut adjustment	Adjust free cuts
	Workpiece sticks Operating error	Place wedge in cut or use thicker riving knife Feed workpiece left or right on fence. When cutting with the sliding table do not feed the workpiece at the rip fence
Workpiece has burn marks	Blunt saw blade	Changing the saw blade
	Saw blade has too many teeth	Increase speed of feed
	Sägeblatt hat zu viele Zähne	Change saw blade
	Incorrect free cut	Adjust free cut
Tears instead of scorer	Scorer not aligned with main saw	Adjust free cuts; the free cut should be almost „0“
	Scorer blade too narrow	Set saw width blade
Workpiece lifts when cutting with the scorer	Scorer blade blunt	Replace
	Cutting height too small	Set blade higher
E01	End switch ES_Min1 reached	
E03	End switch ES_Max reached	
E04	Emergency switch actuated	Control emergency switches/door/cover
E07	Error positioning drive	
quick blinking (4Hz) in the ON-switch	Overtemperature mainsaw motor	
slow blinking (1Hz) in the ON-switch	Error brake: Mains relay is not in 0-position	
LED rotation speed blinking	No input signal	

9 Maintenance



Before performing any maintenance always switch off the main switch and prevent it from being switched on again!

Regular cleaning of the machine extends its working life and is also a requirement for problem-free cutting. The sliding table saw should therefore, depending on how dirty it is, be cleaned at least once a week. The particular areas affected are:

the machine table

the sliding table

the sliding table guides

the tilting segments

the bar of the rip fence

the interior of the machine

the machine environment

Sawdust and dust adhering is removed with a vacuum cleaner. To remove resin residues it is best to use a cleaning solvent. It is essential that parts treated in this way are treated afterwards with an oil-soaked cloth to avoid the buildup of rust.

The sliding table guides are to be cleaned regularly. If contaminated with resin, the guides are to be cleaned with petroleum and possibly using Scotch Brite pads for example. It is not advisable to use steel wool or sandpaper since this than irreparably damages the guide tracks.

Before using a solvent and cleaner you must make sure that this substance will not cause any damage to the lacquered, anodized or zinc-plated surfaces as well as to plastic parts. You can obtain information about this by consulting the safety data sheets for this substance (obtainable from makers of solvents or cleaners).

9.1 Lubrication

9.2 Brake

9.1.1 Saw drive shaft

The bearings of the main saw shaft and the scorer saw shaft are sealed for life so that no subsequent lubrication is needed.

9.1.2 Tilt segments

The tilt segments are to be cleaned and lubricated on a regular basis. The intervals for such work (2 weeks) depend on the period of use

The electronic brake of the main saw unit is not subject to wear!

www.DaltonsWadkin.com

10 Customer service - spare parts

Holding a stock of the most important spares and parts that wear out is an important prerequisite for the ongoing function and availability of the sliding table saw.

To order spare parts please use the spare parts list.

The spare parts codes entered in the spare parts list provide further information.

We only accept a guarantee for original spare parts supplied by us.

We would explicitly point out that spare parts and accessories not originally supplied by us are not tested and released by us. Fitting and/or use of such products can therefore under some circumstances negatively affect the characteristics specified by the construction of the sliding table saw and thereby adversely affect active and/or passive safety. No liability or warranty claims are accepted by Wilhelm Altendorf GmbH & Co KG for damage arising from use on non-original spare parts.

Please note that there are often special manufacturing and delivery specifications for own and third-party parts and that we always supply you with spare parts to the latest technical specification and in line with the latest official regulation

When ordering spares please quote the following information:

Machinen number

Item no.

Our address for spare parts sales and customer service:

Wilhelm Altendorf GmbH & Co KG

Service department

Wettinerallee 43-45

D-32429 Minden

Postfach 20 09

D-32377 Minden

Telephone: +49 571/95500

Fax : +49 571/9550111